

Doc 9284
AN/905



Technical Instructions for the Safe Transport of Dangerous Goods by Air

Approved and published by
decision of the Council of ICAO

2015 – 2016 Edition

International Civil Aviation Organization

Doc 9284
AN/905



Technical Instructions for the Safe Transport of Dangerous Goods by Air

Approved and published by
decision of the Council of ICAO

2015-2016 Edition

International Civil Aviation Organization

Published in separate English, Chinese, French,
Russian and Spanish editions by the
INTERNATIONAL CIVIL AVIATION ORGANIZATION
999 University Street, Montréal, Quebec, Canada H3C 5H7

For ordering information and for a complete listing of sales agents
and booksellers, please go to the ICAO website at www.icao.int

2015–2016 Edition

**ICAO Doc 9284, Technical Instructions for the Safe Transport of
Dangerous Goods by Air**

Order Number: Doc 9284
ISBN 978-92-9249-582-4
ISSN 1726-6181

© ICAO 2014

All rights reserved. No part of this publication may be reproduced, stored in a
retrieval system or transmitted in any form or by any means, without prior
permission in writing from the International Civil Aviation Organization.

The designations employed and the presentation of the material in this
publication do not imply the expression of any opinion whatsoever on the
part of ICAO concerning the legal status of any country, territory, city or area,
or of its authorities, or concerning the delimitation of its frontiers or boundaries.

FOREWORD

RELATIONSHIP TO ANNEX 18 TO THE CHICAGO CONVENTION

The broad principles governing the international transport of dangerous goods by air are contained in Annex 18 to the Convention on International Civil Aviation — *The Safe Transport of Dangerous Goods by Air*. These Technical Instructions amplify the basic provisions of Annex 18 and contain all the detailed instructions necessary for the safe international transport of dangerous goods by air. Interested persons may purchase copies of Annex 18 from ICAO at the following address:

International Civil Aviation Organization
 Customer Services Unit
 999 University Street, Montréal, Quebec, Canada, H3C 5H7
 Tel.: +1 514-954-8022
 Fax: +1 514-954-6769
 Email: sales@icao.int
 Internet home page: www.icao.int

VARIATIONS FROM THE TECHNICAL INSTRUCTIONS

In accordance with the provisions of Annex 18, 2.5, Contracting States are required to notify ICAO of those cases where they have adopted provisions different from those contained in these Instructions. The variations which have been notified by States are listed in Attachment 3, together with notified variations from airline operators.

UPDATING PROCEDURE

It is intended that the Technical Instructions be kept up to date by an ICAO body of experts. For this purpose, the ICAO Dangerous Goods Panel will continue to meet periodically to review comments received from States and interested international organizations, to consider any changed recommendations of the United Nations Subcommittee of Experts on the Transport of Dangerous Goods or the International Atomic Energy Agency, and to prepare revised editions of the Technical Instructions. Amendments recommended by the Dangerous Goods Panel will be reviewed by the Air Navigation Commission. The Council of ICAO will then consider, with a view to approval, the amended version of the Technical Instructions and authorize its publication. Amendments will be made available on www.icao.int/anb/fls/dangerousgoods.

OPERATIONAL USE OF THE TECHNICAL INSTRUCTIONS

- ≠ This edition of the Technical Instructions is required to be used for operations from 1 January 2015 and will remain valid until 31 December 2016 or until such later time as a new edition becomes valid.

GENERAL PRINCIPLES USED IN DEVELOPING THE PROVISIONS OF THE TECHNICAL INSTRUCTIONS

Dangerous goods can be carried safely by air transport providing certain principles are adopted. These principles have been used in developing these Technical Instructions and are set out below; they are intended to facilitate transport while giving a level of safety such that dangerous goods can be carried without placing an aircraft or its occupants at risk, providing all the requirements are fulfilled. They try to ensure that should an incident occur it cannot lead to an accident.

In general, dangerous goods are divided into various classes or divisions according to the hazard they present. A detailed list of individual commodities is shown which indicates the class or division into which each commodity falls as well as its acceptability for transport by air and under what conditions. Since such a list cannot be exhaustive, it also includes various generic or “not otherwise specified” entries to assist in the transport of those commodities not specifically listed by name.

Some dangerous goods are identified as too dangerous ever to be carried on any aircraft; some are forbidden in normal circumstances but may be carried with specific approval from the States concerned; some are restricted to carriage only on all-cargo aircraft; but most may be carried on both passenger and all-cargo aircraft, subject to meeting the required conditions. Those restricted to all-cargo aircraft are either in larger quantities than allowed on passenger aircraft or are forbidden on such aircraft; their transport is permitted due to their being usually accessible in flight and to the ability of the flight crew to consider a greater range of actions in an emergency than is possible on passenger aircraft.

The provisions are based on material produced by the United Nations, which is contained in the Recommendations on the Transport of Dangerous Goods (ST/SG/AC.10/1), the Recommendations on the Transport of Dangerous Goods: Tests and Criteria (ST/SG/AC.10/11), and, for radioactive materials, the International Atomic Energy Agency Regulations for the Safe Transport of Radioactive Material (TS-R-1 (ST-1, Revised)). Using a United Nations system ensures compatibility between the international modes of transport so a consignment may be carried by more than one mode without intermediate reclassification and repacking. Modifications are made to the system to take account of the peculiarities of air transport, while keeping in mind the need to ensure modal compatibility.

There are packing requirements of a general nature and packing instructions which, together, are intended to ensure that the safety of dangerous goods in air transport is assured by their packagings and the way in which they are packed. The packing requirements apply in almost all circumstances; the packing instructions mostly use UN packagings but sometimes these are not required, for instance when dangerous goods are in limited quantities. There is usually a wide choice of inner and outer packagings and single packagings are often permitted; sometimes, however, very restrictive packagings or only one or two types are permitted, or triple packagings are required. Generally, the quantity which can be put into an inner packaging and a complete package is strictly controlled. This is to minimize the inherent risk presented by the dangerous goods so that if an incident should occur, the situation would not produce an unacceptable hazard or lead to injury or major property damage.

After dangerous goods have been packed, the packages are marked with essential information, including the proper shipping name and UN number, and labels depicting all the potential hazard(s) of the contents are affixed. This is to ensure packages containing dangerous goods can be recognized and warning given of the potential hazard(s) without relying on information on accompanying documents. A dangerous goods transport document accompanies most consignments to provide detailed information about the goods so that, if required, there is a separate means of identifying the contents of packages.

There is generally no restriction on the number of packages of dangerous goods which can be loaded on an aircraft but there are provisions for their stowage. Incompatible dangerous goods are segregated and most are separated from passengers. The pilot-in-command is informed of what is on board an aircraft since, among other things, in an emergency the dangerous goods need to be considered when deciding on action. If an in-flight emergency does occur, the pilot-in-command needs to convey information to the air traffic services, in order to aid the response to such an accident or incident. In the event of an accident or incident, information is provided by the operator to the relevant authority as quickly as possible so as to ensure that any hazard arising from damage to the dangerous goods is minimized.

Dangerous goods accidents and incidents have to be reported so that an investigation by a relevant authority can establish the cause and take action to prevent a recurrence, wherever possible. In particular, any weakness or error in the Technical Instructions has to be identified.

Training is an important aid to achieving an understanding of the philosophy and requirements of the Technical Instructions. There is a need for everyone concerned to receive training on the subject either for general familiarization or to provide detailed knowledge, so that the responsibilities of the individual can be met. Dangerous goods are very unlikely to cause a problem when they are prepared and handled in compliance with the Technical Instructions.

USE OF THE TECHNICAL INSTRUCTIONS

The Technical Instructions are divided into eight Parts and four Attachments, with each Part and Attachment divided into Chapters and each Chapter divided into paragraphs and subparagraphs.

Within each Chapter, the Chapter number is incorporated into all of the paragraph numbers; thus, in Chapter 3, paragraph 2 carries the number "3.2". When referring to a paragraph, it is necessary to identify the appropriate Part or Attachment; if the above example were located in Part 2, the reference to it would be shown as "2;3.2" (that is, Part 2; Chapter 3, paragraph 3.2). If the above example were located in Attachment 3, the reference would be shown as "A3;3.2" (that is, Attachment 3; Chapter 3, paragraph 3.2).

Figures and Tables are numbered sequentially within the Part or Attachment in which they appear. Thus, the second figure appearing in Part 4 is identified as "Figure 4-2" and the first table appearing in Part 3 is identified as "Table 3-1". The first table appearing in the Attachments is identified as "Table A-1".

Use of the Technical Instructions will be facilitated by reference to the detailed Index in Attachment 4.

The detailed content of the Technical Instructions gives all the necessary provisions to enable a consignment of dangerous goods to be correctly prepared for air transport. However, to assist the user of this document, the following step-by-step procedure is given for guidance to ensure all the applicable requirements for classifying, packing, labelling, marking and documenting are met.

It should be noted that the information given below is for guidance only and the relevant sections should be checked to ascertain their relevance to each consignment.

1. Determine the correct technical name or composition of the substance or the description of the article.
2. Ascertain whether the name or composition of the substance or article appears in Table 3-1 and if so what is the proper shipping name.

3. If the substance or article does not appear in Table 3-1, determine the class or division into which it falls by comparing its known properties with the definitions for the various classes, which are given in Part 2, Chapters 1 to 9. If the properties are not known, tests should be carried out to determine the appropriate class or division. If the article or substance is not listed by name in Table 3-1 and does not meet the definition of any of the classes, it is not subject to these requirements for the transport of dangerous goods. For substances or articles with multiple hazards, the provisions of Part 2, Introductory Chapter should be followed. Once all the properties of the substance or article are known, determine whether it is forbidden for transport under any circumstance according to the provisions of 1;2.1. If the substance or article does not come within the provisions of 1;2.1, determine the proper shipping name from the most appropriate of the n.o.s. entries in Table 3-1. Information on n.o.s. entries is given in Part 2, Introductory Chapter.
4. If it is desired to transport the substance or article under the provisions for excepted quantities, all the requirements of 3;5 must be met. The substance or article will then not be subject to any of the other requirements of the Technical Instructions other than those listed in 3;5.1.1.
5. If it is desired to transport the substance or article under the provisions for limited quantities, all the requirements of 3;4 must be met and also all the applicable requirements of the Technical Instructions, except where otherwise provided for in 3;4.
6. If the substance or article is not to be transported as an excepted quantity or a limited quantity, determine whether it is desired to transport it on passenger or cargo aircraft.
7. From the information given in columns 10 to 13 of Table 3-1, ascertain whether or not the substance or article is forbidden for transport on passenger aircraft or on both passenger and cargo aircraft.
8. If the substance or article is shown as forbidden for transport on either passenger aircraft or both passenger and cargo aircraft, ascertain whether it could be subject to an exemption under the provisions of 1;1.1.2, by consulting the appropriate national authority. If the substance or article is forbidden for transport on passenger aircraft, determine whether it can be transported on cargo aircraft.
9. If it is desired to transport the substance or article on passenger aircraft and this is not forbidden and the quantity per package does not exceed the permitted maximum net quantity per package given in column 11 of Table 3-1, determine the packing instruction number, quantity limitation, special provisions and any State or operator variations as shown in Tables 3-1 and 3-2 and Attachment 3.
10. If it is desired to transport the substance or article on a cargo aircraft or if it can only be carried on such aircraft, determine the packing instruction number, quantity limitation, special provisions and any State or operator variations as shown in Tables 3-1 and 3-2 and Attachment 3.
11. Determine the packing details from the relevant information or packing instruction in Part 4 and any special requirements from Part 2, Chapters 1 to 9 and Part 5, Chapter 1.
12. Select, where permitted, a method of packing from the packing instruction, or ascertain the provisions of the instruction and ensure the packagings to be used meet all the relevant requirements of Part 4, Chapter 1 and Part 6.
13. Prepare the consignment in accordance with all the relevant requirements of paragraphs 9 to 12 above.
14. Ensure all the appropriate labels and markings are affixed to or printed on the packages according to Part 5, Chapters 2 and 3.
15. Make any appropriate advance arrangements in accordance with Part 5, Chapter 1.
16. Prepare the transport documents and complete and sign the dangerous goods transport document in accordance with Part 5, Chapter 4.
17. Offer the complete consignment for transport by air.

THE SUPPLEMENT TO THE TECHNICAL INSTRUCTIONS

A Supplement to the Technical Instructions provides information on the safe transport of dangerous goods by air that is primarily of interest to States. Publishing this information in a separate document eliminates from the Technical Instructions material which the average user has neither the need nor the desire to know. The size and complexity of the Technical Instructions is thereby reduced and its comprehensibility enhanced. Examples of the subjects dealt with in the Supplement are guidance for the issue of certain exemptions or approvals by States and the reporting of dangerous goods accidents and incidents to ICAO by Contracting States.

The Supplement is published at the same time as the Technical Instructions and is distributed to the aviation administrations of all the Contracting States of ICAO. However, it is recognized that there may be occasions when the information in the Supplement might be helpful to other readers. Copies can be purchased from the Regional Offices of ICAO or from the Headquarters of ICAO using the following address:

International Civil Aviation Organization
 Customer Services Unit
 999 University Street, Montréal, Quebec, Canada, H3C 5H7
 Tel.: +1 514-954-8022
 Fax: +1 514-954-6769
 Email: sales@icao.int
 Internet home page: www.icao.int

THE 2015-2016 EDITION

The Technical Instructions have been amended to make them as up to date as possible and to clarify, where necessary, the intent of the requirements. Account has been taken of comments received from users throughout the world. This has resulted in numerous minor changes in all parts of the book.

- ≠ It is intended, for the time being, to continue issuing new versions of the Technical Instructions biennially. This is the fifteenth biennial edition of the Technical Instructions and it will be valid for two years, i.e. from 1 January 2015 to 31 December 2016 or until such later time as a new edition becomes valid.
- ≠ The requirements have been amended so as to align them, as far as possible, with the Eighteenth Revised Edition of the United Nations *Recommendations on the Transport of Dangerous Goods* and the *International Atomic Energy Agency (IAEA) Regulations for the Safe Transport of Radioactive Material*, as incorporated therein.
- ≠ The amendments include the following:
 - revisions to general provisions including:
 - addition of new exceptions related to ice jam control and landslide clearance (1;1.1.5.1 c));
 - addition of new exceptions for lamps containing dangerous goods (1;2.6) and consequential revisions to Special Provision A69 (3;3);
 - addition of new definitions for Large salvage packagings, Management system for the transport of radioactive material, Neutron radiation detector, and Radiation detection system (1;3);
 - revision of definition for net quantity (1;3);
 - addition of flight operations office and flight dispatcher to Tables 1-4 and 1-5 and renumbering of categories of staff in Table 1-5 (1;4);
 - revisions to classification criteria including:
 - clarification that articles are not assigned to packing groups (2;Introductory Chapter, 2.4);
 - alternative classification criteria for Division 5.1 (2;5.2);
 - addition of new exception for samples drawn in connection with tissue or organ transplantation (2;6.3.2.3.7);
 - addition of new requirements for refrigerated or frozen specimens (2;6.3.2.3.8 e));
 - revision to the exception for medical devices or equipment (2;6.3.2.3.9.1);
 - addition of new entries in Table 3-1 including:
 - **Refrigerant gas R 1113** (UN 1082);
 - **Hay, Straw or Bhusa** (UN 1327);
 - **Fibres, animal or vegetable** (UN 1372);
 - **Fish scrap, unstabilized or Fish meal, unstabilized** (UN 1374);
 - **Wool waste, wet** (UN 1387);
 - **Rags, oily** (UN 1856);
 - **Textile waste, wet** (UN 1857);
 - **Fish meal, stabilized or Fish scrap, stabilized** (UN 2216);
 - **Fumigated cargo transport unit** (UN 3359);
 - **Fibres, vegetable, dry** (UN 3360);
 - **Batteries, nickel-metal hydride** (UN 3496);
 - **Krill meal** (UN 3497);
 - **Uranium hexafluoride, radioactive material, excepted package** (UN 3507);
 - **Capacitor, asymmetric** (UN 3508);
 - **Packagings discarded, empty, uncleaned** (UN 3509);

- revisions to proper shipping names including:
 - replacement of **Air bag inflators, Air bag modules** and **Seat-belt pretensioners** with **Safety devices, pyrotechnic** (UN 0503)
 - replacement of **Air bag inflators, Air bag modules** and **Seat-belt pretensioners** with **Safety devices** (UN 3268)
 - replacement of **Blue asbestos** and **Brown asbestos** with **Asbestos, amphibole** (UN 2212)
 - replacement of **White asbestos** with **Asbestos, chrysotile** (UN 2590);
- revisions to special provisions including:
 - Special Provisions A4 and A5: new requirement for special provision code to be noted on dangerous goods transport document;
 - Special Provision A18: removal of exception for mercurous chloride;
 - Special Provision A19: new requirement for fire extinguishers and new provisions for large fire extinguishers;
 - Special Provision A28: revision to exception for **Dichloroisocyanuric acid, dry** (UN 2465) and **Dichloroisocyanuric acid salts** (UN 2465);
 - Special Provisions A32, A56 and A115: alignment with new proper shipping names for UN 0503 and UN 3268;
 - Special Provision A64: clarification that UN test series 2 applies;
 - Special Provision A75: new exception from pressure differential test and venting prohibition;
 - Special Provision A186: new transitional provisions for marking of energy storage capacity requirement on electric double layer capacitors;
 - Special Provision A187: clarification that chemicals under pressure containing components forbidden for transport by air must not be transported by air;
 - Special Provision A190: revision to provisions for neutron radiation detectors containing non-pressurized boron trifluoride;
- addition of the following new special provisions:
 - Special Provision A192: use of paint related material or printing ink related material as a proper shipping name;
 - Special Provision A195: articles containing a small pressure receptacle with a release device;
 - Special Provision A196: new UN No. 3508, **Capacitor, asymmetric**;
 - Special Provision A197: exceptions for small quantities of environmentally hazardous substances;
 - Special Provision A198: exceptions for UN 1327, **Hay** or **Straw** or **Bhusa** when not wet, damp or contaminated;
 - Special Provision A199: exceptions for UN 3496, **Batteries, nickel-metal hydride**;
 - Special Provision A200: prohibition on the transport by air of UN 3509, **Packagings discarded, empty, uncleaned**;
 - Special Provision A201: provision for the transport of a consignment of UN 3090 — **Lithium metal batteries** on passenger aircraft (see revisions to lithium battery provisions listed below);
- revisions to marking and labelling requirements including:
 - clarification of the minimum dimensions and format of dangerous goods marks and labels (3;4, 3;5, Packing Instructions 650 and 959, 5;2, 5;3, 6;2);
 - addition of minimum height requirement for salvage packaging and overpack marking (5;1.5 and 5;2.4.10);
- revisions to packing requirements including:
 - addition of provisions allowing for the use of supplemental packaging to provide additional protection (4;1.1.10.2);
 - clarification of testing requirements for outer packagings in Packing Instructions 203 and Y203 (4;4);
 - new provisions for large fire extinguishers to be transported unpackaged in Packing Instruction 213 (4;4);
 - addition of provisions to allow for limited venting of oxygen in the case of specialized peroxyacetic acid packagings in Packing Instruction 570;
 - addition of references to general provisions for lithium batteries in Packing Instructions 950, 951 and 952 (4;11);
 - addition of requirements for life-saving appliances containing batteries in Packing Instruction 955 (4;11);
 - clarification of criteria for passing the drop test in Packing Instruction Y963 (4;11);
 - addition of new UN 3508, **Capacitor, asymmetric** to Packing Instruction 971 (4;11);
 - removal of provisions for overpacks containing dangerous goods permitted on cargo aircraft only (5;1.1 e));
- revisions to packaging marking and test requirements:
 - addition of provisions for marking on UN tested packagings to allow greater flexibility on how last two digits of the year of manufacture must be displayed (6;2.1.1);
 - addition of transition provisions for ISO Standards for the construction and testing of UN cylinders and closed cryogenic receptacles (6;5);
 - addition of hot water bath test alternatives for small receptacles containing gas and fuel cell cartridges (6;5.4);

- revisions to operator responsibilities including:
 - guidance for operator acceptance staff in recognizing globally harmonized system GHS pictograms (7;1.1.2);
 - removal of provisions for overpacks containing dangerous goods permitted on cargo aircraft only (7;1.3.1);
 - timing of acceptance checks (7;1.3);
 - addition of requirement for information on unit load device identification tags to be legible and visible (7;2.8);
 - removal of segregation requirements for toxic and infectious substances (7;2.9);
 - removal of requirement for technical name to appear with the information to the pilot-in-command (7;4.1.1);
 - clarification of requirements for providing dangerous goods information to passengers (7;5.1);
 - update to indicative list of items with potential to include dangerous goods (7;6);
- revisions to provisions for radioactive material including:
 - radioactive material in the mail (1;2.3.2 c);
 - general provisions (1;6);
 - new provisions for uranium hexafluoride, radioactive material, excepted package (2; Introductory Chapter, 2;4.2, 2;7, Table 3-1 (UN 3507) (3;2), Special Provisions A193 and A194 (3;2), Packing Instruction 877);
 - new requirements criteria for fissile material (2;7);
 - revision to definitions for design, exclusive use and freight container (2;7.1.3);
 - revisions to provisions for determination of activity level (2;7.2.2);
 - revisions to exceptions for specimens of special form radiation that comprise or simulate radioactive material enclosed in a sealed capsule (2;7.2.3.3.6);
 - revisions to criteria for classifying packages as excepted packages (2;7.2.4)
 - addition of new exception from “RADIOACTIVE” marking for UN 2911 — **Radioactive material, excepted package — instruments** (2;7.2.4.1.1.3);
 - clarification of provisions for the transport of empty Type B(U) or Type B(M) packages (2;7.2.4.1.1.7, 5;2.4.5.4 and 5;4.1.5.7);
 - revisions to documentation and package marking requirements in Special Provision A78 (3;2);
 - revisions to packing requirements (4;9)
 - new requirements related to certificates issued by the competent authority (5;1.2.2);
 - new documentation requirements for excepted packages (5;1.2.4);
 - revisions to package testing requirements (6;7);
 - revisions to operator responsibilities (7;2.9);
- addition of new provisions for adsorbed gases including:
 - new definition (2;2.1.2 e);
 - new entries in Table 3-1 (UN Nos. 3510-3526) (3;2);
 - new Packing Instruction 219 (4;4);
 - new design, construction, inspection and testing requirements for UN cylinders (6;5.2.1.7);
- revisions to lithium battery provisions including:
 - prohibition on transport of lithium metal batteries as cargo on passenger aircraft (Table 3-1, Special Provision A201 and Packing Instruction 968);
 - clarification of testing requirements for lithium batteries (2;9.3);
 - addition of requirement for a transport document in Section IB of Packing Instructions 965 and 968;
 - replacement of references to gross quantity limits with net quantity limits in Section IB of Packing Instructions 965 and 968 (4;11);
 - clarification of the limit on the number of batteries permitted in a package when packed with equipment (Packing Instructions 966 and 969 (4;11));
 - new requirement prohibiting sound or light alarms from devices during transport (Packing Instructions 967 and 970 (4;11));
 - removal of redundancies from Packing Instructions 965 to 970 (4;11);
- revisions to list of dangerous goods permitted to be carried by passengers or crew (Table 8-1):
 - new provisions for medical devices other than radioisotopic cardiac pacemakers (Table 8-1, Item 4));
 - new provisions for portable medical electronic devices containing lithium batteries exceeding current limits (Table 8-1, Item 8));
 - expansion of provision for small cartridges fitted into a self-inflating life-jacket to include other types of self-inflating personal safety devices (Table 8-1, Item 18));
 - clarification to distinguish between devices containing batteries and spare batteries (Table 8-1, Item 19));

ABBREVIATIONS AND SYMBOLS

The abbreviations and symbols in the following table are used throughout the Instructions, or in the particular sections indicated, and have the meanings shown below.

<i>Abbreviation or symbol</i>	<i>Meaning</i>
A/m	amperes per metre
Bq	becquerel
cm	centimetre
°C	degree Celsius
G	gross mass as prepared for transport (as used in column 11 of Table 3-1)
g/m ²	grams per square metre
Gy	gray
Hz	hertz
IAEA	International Atomic Energy Agency
IP	inner packaging
ISO	the International Organization for Standardization
J/g	joules per gram
J/kg	joules per kilogram
K	kelvin
kg	kilogram
kgf	kilogram-force
kPa	kilopascal
L	litre
LC	lethal concentration
LD	lethal dose
L/kg	litres per kilogram
m	metre
mL	millilitre
mm	millimetre
mS/m	millisiemens per metre
N	newton
n.o.s.	not otherwise specified
Ω/m	ohm per metre
SI	the International System of Units developed by the General Conference of Weights and Measures (Système international d'unités)
Sv	sievert
UN	the United Nations Committee of Experts on the Transport of Dangerous Goods
W/m ²	watts per square metre
W/m/K	Watts per metre per Kelvin
µm	micrometre
≠	this symbol indicates changed text
+	this symbol indicates new or relocated text
>	this symbol indicates deleted text

TABLE OF CONTENTS

	<i>Page</i>
Part 1. GENERAL	
Chapter 1. Scope and applicability	1-1-1
1.1 General applicability.....	1-1-1
1.2 General transport requirements.....	1-1-3
1.3 Application of standards.....	1-1-3
1.4 Dangerous goods packages opened by customs and other authorities	1-1-3
1.5 Relationship to Annex 18.....	1-1-3
1.6 Requests for amendments to the Technical Instructions.....	1-1-3
Chapter 2. Limitation of dangerous goods on aircraft	1-2-1
2.1 Dangerous goods forbidden for transport by air under any circumstance	1-2-1
2.2 Exceptions for dangerous goods of the operator.....	1-2-1
2.3 Transport of dangerous goods by post.....	1-2-2
2.4 Dangerous goods in excepted quantities.....	1-2-2
2.5 Exceptions for dangerous goods packed in limited quantities.....	1-2-2
2.6 Lamps containing dangerous goods.....	1-2-2
Chapter 3. General information	1-3-1
3.1 Definitions	1-3-1
3.2 Units of measurement and conversion factors	1-3-8
Chapter 4. Training	1-4-1
4.1 Establishment of training programmes.....	1-4-1
4.2 Training curricula	1-4-1
4.3 Instructor qualifications	1-4-3
4.4 Competency-based training and assessment	1-4-4
Chapter 5. Dangerous goods security.....	1-5-1
5.1 General security provisions.....	1-5-1
5.2 Dangerous goods security training	1-5-1
5.3 Provisions for high consequence dangerous goods.....	1-5-1
5.4 Security plans.....	1-5-3
5.5 Radioactive material	1-5-4
Chapter 6. General provisions concerning radioactive material.....	1-6-1
6.1 Scope and application.....	1-6-1
6.2 Radiation protection programme	1-6-2
6.3 Management system.....	1-6-3
6.4 Special arrangement.....	1-6-3
6.5 Radioactive material possessing other dangerous properties.....	1-6-3
6.6 Non-compliance	1-6-3
Chapter 7. Incident and accident reporting	1-7-1
Part 2. CLASSIFICATION OF DANGEROUS GOODS	
Introductory Chapter	2-0-1
Chapter 1. Class 1 — Explosives	2-1-1
1.1 Definitions and general provisions.....	2-1-1
1.2 Definitions	2-1-1
1.3 Divisions.....	2-1-2
1.4 Compatibility groups	2-1-2
1.5 Classification of explosives.....	2-1-3

	<i>Page</i>
Chapter 2. Class 2 — Gases	2-2-1
2.1 Definitions and general provisions	2-2-1
2.2 Divisions	2-2-1
2.3 Hazard precedence	2-2-2
2.4 Mixtures of gases	2-2-2
2.5 Aerosols	2-2-3
Chapter 3. Class 3 — Flammable liquids	2-3-1
Introductory Notes	2-3-1
3.1 Definition and general provisions	2-3-1
3.2 Assignment of packing groups	2-3-1
3.3 Determination of flash point	2-3-2
3.4 Determination of initial boiling point	2-3-2
Chapter 4. Class 4 — Flammable solids; substances liable to spontaneous combustion; substances which, in contact with water, emit flammable gases	2-4-1
Introductory Notes	2-4-1
4.1 Definitions and general provisions	2-4-1
4.2 Flammable solids, self-reactive substances and desensitized explosives	2-4-2
4.3 Substances liable to spontaneous combustion (Division 4.2)	2-4-6
4.4 Substances which, in contact with water, emit flammable gases (Division 4.3)	2-4-8
4.5 Classification of organometallic substances	2-4-8
Chapter 5. Class 5 — Oxidizing substances; organic peroxides	2-5-1
Introductory Note	2-5-1
5.1 Definitions and general provisions	2-5-1
5.2 Oxidizing substances (Division 5.1)	2-5-1
5.3 Organic peroxides (Division 5.2)	2-5-3
Chapter 6. Class 6 — Toxic and infectious substances	2-6-1
Introductory Note	2-6-1
6.1 Definitions	2-6-1
6.2 Division 6.1 — Toxic substances	2-6-1
6.3 Division 6.2 — Infectious substances	2-6-5
Chapter 7. Class 7 — Radioactive material	2-7-1
7.1 Definitions	2-7-1
7.2 Classification	2-7-2
Chapter 8. Class 8 — Corrosive substances	2-8-1
8.1 Definition of Class 8	2-8-1
8.2 Assignment of packing groups	2-8-1
Chapter 9. Class 9 — Miscellaneous dangerous substances and articles, including environmentally hazardous substances	2-9-1
9.1 Definition	2-9-1
9.2 Assignment to Class 9	2-9-1
9.3 Lithium batteries	2-9-2

	<i>Page</i>
Part 3. DANGEROUS GOODS LIST, SPECIAL PROVISIONS AND LIMITED AND EXCEPTED QUANTITIES	
Chapter 1. General	3-1-1
1.1 General	3-1-1
1.2 Proper shipping name	3-1-1
1.3 Mixtures or solutions	3-1-2
Chapter 2. Arrangement of the dangerous goods list (Table 3-1)	3-2-1
2.1 Arrangement of the dangerous goods list (Table 3-1)	3-2-1
Chapter 3. Special provisions	3-3-1
Chapter 4. Dangerous goods in limited quantities	3-4-1
4.1 Applicability	3-4-1
4.2 Packing and packagings	3-4-2
4.3 Quantity limitations	3-4-2
4.4 Package testing	3-4-2
4.5 Package marking	3-4-3
4.6 Package labelling	3-4-3
4.7 Dangerous goods transport document	3-4-3
Chapter 5. Dangerous goods packed in excepted quantities	3-5-1
5.1 Excepted quantities	3-5-1
5.2 Packagings	3-5-2
5.3 Tests for packages	3-5-2
5.4 Marking of packages	3-5-2
5.5 Documentation	3-5-3
5.6 De minimis quantities	3-5-3

Part 4. PACKING INSTRUCTIONS

Introductory Notes.....	4-(i)
Chapter 1. General packing requirements	4-1-1
1.1 General requirements applicable to all classes except Class 7	4-1-1
1.2 Packing group	4-1-5
1.3 Transitional packaging arrangements for radioactive material	4-1-6
1.4 Salvage packagings	4-1-6
Chapter 2. General	4-2-1
Chapter 3. Class 1 — Explosives	4-3-1
3.1 Packing group	4-3-1
3.2 General requirements	4-3-1
3.3 General packing provisions	4-3-1
3.4 Packing instructions	4-3-2
Chapter 4. Class 2 — Gases	4-4-1
4.1 Special packing provisions for dangerous goods of Class 2	4-4-1
4.2 Packing instructions	4-4-2
Chapter 5. Class 3 — Flammable liquids	4-5-1
5.1 Packing instructions	4-5-1
Chapter 6. Class 4 — Flammable solids; substances liable to spontaneous combustion; substances which, in contact with water, emit flammable gases	4-6-1
6.1 General requirements for self-reactive substances	4-6-1
6.2 Packing instructions	4-6-1

	<i>Page</i>
Chapter 7. Class 5 — Oxidizing substances; organic peroxides	4-7-1
7.1 General requirements for organic peroxides	4-7-1
7.2 Packing instructions	4-7-1
Chapter 8. Class 6 — Toxic and infectious substances	4-8-1
8.1 Packing instructions	4-8-1
Chapter 9. Class 7 — Radioactive material	4-9-1
9.1 General	4-9-1
9.2 Requirements and controls for transport of LSA material and SCO	4-9-2
9.3 Packages containing fissile material	4-9-3
Chapter 10. Class 8 — Corrosive substances	4-10-1
10.1 Packing instructions	4-10-1
Chapter 11. Class 9 — Miscellaneous dangerous goods	4-11-1

Part 5. SHIPPER'S RESPONSIBILITIES

Chapter 1. General	5-1-1
1.1 General requirements	5-1-1
1.2 General provisions for Class 7	5-1-2
1.3 Information to employees	5-1-5
1.4 Training	5-1-5
1.5 Salvage packagings	5-1-6
1.6 Empty packagings	5-1-6
1.7 Mixed packing	5-1-6
Chapter 2. Package markings	5-2-1
2.1 The requirement to mark	5-2-1
2.2 Application of markings	5-2-1
2.3 Prohibited marking	5-2-1
2.4 Marking specifications and requirements	5-2-1
2.5 Languages to be used	5-2-5
Chapter 3. Labelling	5-3-1
3.1 The requirement to label	5-3-1
3.2 Application of labels	5-3-1
3.3 Labelling of overpacks	5-3-3
3.4 Prohibited labelling	5-3-3
3.5 Label specifications	5-3-3
3.6 Placarding of large freight containers containing radioactive material	5-3-5
Chapter 4. Documentation	5-4-1
4.1 Dangerous goods transport information	5-4-1
4.2 Air waybill	5-4-6
4.3 Additional documentation for other than radioactive material	5-4-6
4.4 Retention of dangerous goods transport information	5-4-6

Part 6. PACKAGING NOMENCLATURE, MARKING, REQUIREMENTS AND TESTS

Chapter 1. Applicability, nomenclature and codes	6-1-1
1.1 Applicability	6-1-1
1.2 Codes for designating types of packagings	6-1-1
1.3 Index of packagings	6-1-2

	<i>Page</i>
Chapter 2. Marking of packagings other than inner packagings.....	6-2-1
Introductory Notes.....	6-2-1
2.1 Marking requirements for packagings other than inner packagings.....	6-2-1
2.2 Packaging markings for infectious substances.....	6-2-3
2.3 Packaging markings for salvage packagings	6-2-3
2.4 Packaging markings for intermediate bulk containers	6-2-4
Chapter 3. Requirements for packagings	6-3-1
3.1 Requirements for packagings other than inner packagings	6-3-1
3.2 Requirements for inner packagings	6-3-8
Chapter 4. Packaging performance tests.....	6-4-1
Introductory Notes.....	6-4-1
4.1 Performance and frequency of tests.....	6-4-1
4.2 Preparation of packagings for testing	6-4-2
4.3 Drop test.....	6-4-2
4.4 Leakproofness test.....	6-4-4
4.5 Internal pressure (hydraulic) test	6-4-5
4.6 Stacking test.....	6-4-5
4.7 Test report.....	6-4-6
4.8 Test requirements for salvage packaging.....	6-4-6
Chapter 5. Requirements for the construction and testing of cylinders and closed cryogenic receptacles, aerosol dispensers and small receptacles containing gas (gas cartridges) and fuel cell cartridges containing liquefied flammable gas	6-5-1
5.1 General requirements	6-5-1
5.2 Requirements for UN cylinders and closed cryogenic receptacles	6-5-5
5.3 Requirements for non-UN cylinders and non-UN closed cryogenic receptacles	6-5-18
5.4 Requirements for aerosol dispensers, small receptacles containing gas (gas cartridges) and fuel cell cartridges containing liquefied flammable gas	6-5-18
Chapter 6. Packagings for infectious substances of Category A	6-6-1
6.1 General	6-6-1
6.2 Requirements for packagings	6-6-1
6.3 Code for designating types of packagings.....	6-6-1
6.4 Marking	6-6-1
6.5 Test requirements for packagings	6-6-2
Chapter 7. Requirements for the construction, testing and approval of packages for radioactive material and for the approval of such material.....	6-7-1
7.1 General requirements	6-7-1
7.2 Additional requirements for packages transported by air	6-7-1
7.3 Requirements for excepted packages	6-7-2
7.4 Requirements for industrial packages	6-7-2
7.5 Requirements for packages containing uranium hexafluoride	6-7-2
7.6 Requirements for Type A packages	6-7-3
7.7 Requirements for Type B(U) packages	6-7-4
7.8 Requirements for Type B(M) packages.....	6-7-6
7.9 Requirements for Type C packages	6-7-6
7.10 Requirements for packages containing fissile material	6-7-6
7.11 Test procedures and demonstration of compliance.....	6-7-9
7.12 Testing the integrity of the containment system and shielding and evaluating criticality safety.....	6-7-10
7.13 Target for drop tests.....	6-7-10
7.14 Tests for demonstrating ability to withstand normal conditions of transport.....	6-7-10
7.15 Additional tests for Type A packages designed for liquids and gases	6-7-11
7.16 Tests for demonstrating the ability to withstand accident conditions in transport	6-7-11
7.17 Enhanced water immersion test for Type B(U) and Type B(M) packages containing more than 10 ⁵ A ₂ , and Type C packages	6-7-12
7.18 Water leakage test for packages containing fissile material.....	6-7-12
7.19 Tests for Type C packages	6-7-13
7.20 Tests for packagings designed to contain uranium hexafluoride	6-7-13
7.21 Approvals of package designs and materials	6-7-13

	<i>Page</i>
7.22 Applications and approvals for radioactive material transport.....	6-7-14
7.23 Registration of serial numbers and validation.....	6-7-14
7.24 Transitional measures for Class 7.....	6-7-14
 Part 7. OPERATOR'S RESPONSIBILITIES 	
Introductory Note.....	7-(i)
Chapter 1. Acceptance procedures.....	7-1-1
1.1 Cargo acceptance procedures.....	7-1-1
1.2 Acceptance of dangerous goods by operators.....	7-1-1
1.3 The acceptance check.....	7-1-1
1.4 Acceptance of freight containers and unit load devices.....	7-1-2
1.5 Special responsibilities in accepting infectious substances.....	7-1-2
1.6 Undeliverable consignments of radioactive material.....	7-1-3
Chapter 2. Storage and loading.....	7-2-1
2.1 Loading restrictions on the flight deck and for passenger aircraft.....	7-2-1
2.2 Incompatible dangerous goods.....	7-2-1
2.3 Handling and loading of packages containing liquid dangerous goods.....	7-2-3
2.4 Loading and securing of dangerous goods.....	7-2-3
2.5 Damaged packages of dangerous goods.....	7-2-4
2.6 Visibility of markings and labels.....	7-2-4
2.7 Replacement of labels.....	7-2-4
2.8 Identification of unit load devices containing dangerous goods.....	7-2-4
2.9 Special provisions applicable to the carriage of radioactive material.....	7-2-4
2.10 Loading of magnetized materials.....	7-2-8
2.11 Loading of dry ice.....	7-2-9
2.12 Loading of UN 2211, polymeric beads, expandable or UN 3314, plastics moulding compound.....	7-2-9
2.13 Handling of self-reactive substances and organic peroxides.....	7-2-9
2.14 Handling and loading of intermediate bulk containers (IBCs).....	7-2-9
Chapter 3. Inspection and decontamination.....	7-3-1
3.1 Inspection for damage or leakage.....	7-3-1
3.2 Damaged or leaking packages of radioactive material, contaminated packagings.....	7-3-1
3.3 Dealing with suspected contaminated baggage or cargo.....	7-3-2
Chapter 4. Provision of information.....	7-4-1
Introductory Note.....	7-4-1
4.1 Information to the pilot-in-command.....	7-4-1
4.2 Information to be provided to employees.....	7-4-3
4.3 Information to be provided by the pilot-in-command in case of in-flight emergency.....	7-4-3
4.4 Reporting of dangerous goods accidents and incidents.....	7-4-3
4.5 Reporting of undeclared or misdeclared dangerous goods.....	7-4-3
4.6 Reporting of dangerous goods occurrences.....	7-4-4
4.7 Information by the operator in case of an aircraft accident or incident.....	7-4-4
4.8 Cargo acceptance areas — Provision of information.....	7-4-4
4.9 Emergency response information.....	7-4-4
4.10 Training.....	7-4-4
4.11 Retention of documents or information.....	7-4-5
Chapter 5. Provisions concerning passengers and crew.....	7-5-1
5.1 Information to passengers.....	7-5-1
5.2 Passenger check-in procedures.....	7-5-1
Chapter 6. Provisions to aid recognition of undeclared dangerous goods.....	7-6-1
Chapter 7. Helicopter operations.....	7-7-1

Part 8. PROVISIONS CONCERNING PASSENGERS AND CREW

Chapter 1.	Provisions for dangerous goods carried by passengers or crew	8-1-1
1.1	Dangerous goods carried by passengers or crew	8-1-1

ATTACHMENTS

ATTACHMENT 1. Lists of proper shipping names

Chapter 1.	List of UN numbers with associated proper shipping names	A1-1-1
Chapter 2.	List of n.o.s. and generic proper shipping names	A1-2-1

ATTACHMENT 2. Glossary of terms

Glossary of terms		A2-1
-------------------------	--	------

ATTACHMENT 3. Notified variations from the Instructions

Chapter 1.	Variations notified by States	A3-1-1
Chapter 2.	Variations notified by airline operators	A3-2-1

ATTACHMENT 4. Index and list of tables and figures

Index		A4-1
List of tables.....		A4-14
List of figures		A4-15

Part 1
GENERAL

Chapter 1

SCOPE AND APPLICABILITY

Parts of this Chapter are affected by State Variations AE 3, AE 8, BE 2, BE 4, BE 5, BR 4, CA 6, CH 3, DE 1, DE 4, DK 2, FR 2, GB 2, HR 2, HR 3, HR 4, HR 5, IN 1, IR 1, IT 1, IT 5, KH 1, NL 6, RO 1, RO 2, RO 3, US 1, VC 1, VC 2, VC 3, VU 2; see Table A-1

≠ *Note.— Recommendations on Tests and Criteria, which are incorporated by reference into certain provisions of these Instructions, are published as a separate Manual (United Nations Recommendations on the Transport of Dangerous Goods, Manual of Tests and Criteria) (ST/SG/AC.10/11/Rev.5, Amend.1 and Amend. 2), the contents of which are:*

Part I. Classification procedures, test methods and criteria relating to explosives of Class 1;

Part II. Classification procedures, test methods and criteria relating to self-reactive substances of Division 4.1 and organic peroxides of Division 5.2; and

Part III. Classification procedures, test methods and criteria relating to substances or articles of Class 2, Class 3, Class 4, Division 5.1, Class 8 and Class 9.

Appendices. Information common to a number of different types of tests and national contacts for test details.

1.1 GENERAL APPLICABILITY

1.1.1 These *Technical Instructions for the Safe Transport of Dangerous Goods by Air*, referred to herein as the “Instructions”, prescribe the detailed requirements applicable to the international civil transport of dangerous goods by air by any aircraft (including both internal and external carriage). Any addenda to this edition of the ICAO *Technical Instructions for the Safe Transport of Dangerous Goods by Air* issued by ICAO constitute part of these Instructions.

1.1.2 Where specifically provided for in these Instructions, the States concerned may grant an approval provided that in such instances an overall level of safety in transport which is equivalent to the level of safety provided for in these Instructions is achieved.

1.1.3 In instances:

- a) of extreme urgency; or
- b) when other forms of transport are inappropriate; or
- c) when full compliance with the prescribed requirements is contrary to public interest,

the States concerned may grant an exemption from the provisions of the Instructions provided that in such instances every effort is made to achieve an overall level of safety in transport which is at least equivalent to the level of safety provided for in these Instructions.

1.1.4 For the State of overflight, if none of the criteria for granting an exemption are relevant, an exemption may be granted based solely on whether it is believed that an equivalent level of safety in air transport has been achieved.

Note 1.— For the purpose of approvals, “States concerned” are the States of Origin and the Operator, unless otherwise specified in these Instructions.

Note 2.— For the purpose of exemptions, “States concerned” are the States of Origin, Operator, Transit, Overflight and Destination.

Note 3.— Guidance for the processing of exemptions, including examples of extreme urgency, may be found in the Supplement to the Technical Instructions (Part S-1;1.2 and 1.3).

Note 4.— Refer to 1;2.1 for dangerous goods forbidden for transport by air under any circumstance.

Note 5.— Due to the differences in the type of operations carried out by helicopters compared with aeroplanes, some additional considerations need to be made when dangerous goods are carried by helicopter, as described in 7;7.

1.1.5 General exceptions

1.1.5.1 Except for 7.4.2, these Instructions do not apply to dangerous goods carried by an aircraft where the dangerous goods are:

a) to provide, during flight, medical aid to a patient when those dangerous goods:

- 1) have been placed on board with the approval of the operator; or
- 2) form part of the permanent equipment of the aircraft when it has been adapted for specialized use;

providing that:

- 1) gas cylinders have been manufactured specifically for the purpose of containing and transporting that particular gas;
- 2) equipment containing wet cell batteries is kept and, when necessary, secured in an upright position to prevent spillage of the electrolyte;

Note.— For dangerous goods that passengers are permitted to carry as medical aid, see 8;1.1.2.

b) to provide, during flight, veterinary aid or a humane killer for an animal;

≠ c) for dropping in connection with agricultural, horticultural, forestry, avalanche control, ice jam control and landslide clearance or pollution control activities;

d) to provide, during flight, aid in connection with search and rescue operations;

e) vehicles carried in aircraft designed or modified for vehicle ferry operations and all of the following requirements are met:

- 1) authorization has been given by the appropriate authorities of the States concerned, and such authorities have prescribed specific terms and conditions for the particular operator's operation;
- 2) vehicles are secured in an upright position;
- 3) fuel tanks are so filled as to prevent spillage of fuel during loading, unloading and transit; and
- 4) adequate ventilation rates are maintained in the aircraft compartment in which the vehicle is carried;

f) required for the propulsion of the means of transport or the operation of its specialized equipment during transport (e.g. refrigeration units) or that are required in accordance with the operating regulations (e.g. fire extinguishers) (see 2.2).

g) contained within items of excess baggage being sent as cargo provided that:

- 1) the excess baggage has been consigned as cargo by or on behalf of a passenger;
- 2) the dangerous goods may only be those that are permitted by and in accordance with 8;1.1.2 to be carried in checked baggage;
- 3) the excess baggage is marked with the words "Excess baggage consigned as cargo".

1.1.5.2 Provision must be made to stow and secure dangerous goods transported under 1.1.5.1 a), b), c) and d) during take-off and landing and at all other times when deemed necessary by the pilot-in-command.

1.1.5.3 The dangerous goods must be under the control of trained personnel during the time when they are in use on the aircraft.

1.1.5.4 Dangerous goods transported under 1.1.5.1 a), b), c) and d) may be carried on a flight made by the same aircraft before or after a flight for the purposes identified above, when it is impracticable to load or unload the dangerous goods immediately before or after the flight, subject to the following conditions:

- a) the dangerous goods must be capable of withstanding the normal conditions of air transport;
- b) the dangerous goods must be appropriately identified (e.g. by marking or labelling);
- c) the dangerous goods may only be carried with the approval of the operator;
- d) the dangerous goods must be inspected for damage or leakage prior to loading;
- e) loading must be supervised by the operator;

- f) the dangerous goods must be stowed and secured in the aircraft in a manner that will prevent any movement in flight which would change their orientation;
- g) the pilot-in-command must be notified of the dangerous goods loaded on board the aircraft and their loading location. In the event of a crew change, this information must be passed to the next crew;
- h) all personnel must be trained commensurate with their responsibilities;
- i) the provisions of 7;4.2 and 7;4.4 apply.

1.2 GENERAL TRANSPORT REQUIREMENTS

Except as otherwise provided for in these Instructions, no person may offer or accept dangerous goods for international civil transport by air unless those goods are properly classified, documented, certificated, described, packaged, marked, labelled and in the condition for shipment required by these Instructions. If a person performs a function required by these Instructions on behalf of the person who offers the dangerous goods for transport by air or on behalf of the operator, that person must perform that function in accordance with the requirements of these Instructions. No person may transport dangerous goods by air unless those goods are accepted, handled and transported in accordance with these Instructions. No person may label, mark, certify or offer a packaging as meeting the requirements of these Instructions unless that packaging is manufactured, fabricated, marked, maintained, reconditioned or repaired as required by these Instructions. No person shall carry dangerous goods or cause dangerous goods to be carried aboard an aircraft in either checked or carry-on baggage or on his/her person, unless permitted by 8;1.1.2.

Note.— When dangerous goods intended for air transport are carried by surface transport to or from an aerodrome, any other applicable national or modal transport requirements should be met in addition to those that are applicable for the goods when carried by air.

1.3 APPLICATION OF STANDARDS

Where the application of a standard is required and there is any conflict between the standard and these Instructions, the Instructions take precedence.

1.4 DANGEROUS GOODS PACKAGES OPENED BY CUSTOMS AND OTHER AUTHORITIES

Any package opened during an inspection must, before being forwarded to the consignee, be restored by qualified persons to a condition that complies with these Instructions.

1.5 RELATIONSHIP TO ANNEX 18

ICAO Standards and Recommended Practices related to the transport of dangerous goods are contained in Annex 18 to the Convention on International Civil Aviation. These Instructions contain the detailed technical material needed to support the broad provisions of Annex 18 (Fourth Edition) in order to provide a fully comprehensive set of international regulations.

1.6 REQUESTS FOR AMENDMENTS TO THE TECHNICAL INSTRUCTIONS

Any request for an amendment to the Technical Instructions must be submitted to the appropriate national authority. Requests for amendments should include the following information:

- a) the text or substance of the amendment proposed or identification of the provision the petitioner seeks to have repealed, as appropriate;
- b) a statement of the interest of the petitioner in the action requested; and
- c) any information and arguments to support the action sought.

Chapter 2

LIMITATION OF DANGEROUS GOODS ON AIRCRAFT

Parts of this Chapter are affected by State Variations CA 5, DQ 3, FR 6, GB 5, US 2, VC 4, ZA 4; see Table A-1

2.1 DANGEROUS GOODS FORBIDDEN FOR TRANSPORT BY AIR UNDER ANY CIRCUMSTANCE

Any article or substance which, as presented for transport, is liable to explode, dangerously react, produce a flame or dangerous evolution of heat or dangerous emission of toxic, corrosive or flammable gases or vapours under conditions normally encountered in transport must not be carried on aircraft under any circumstance.

Note 1.— Certain dangerous goods known to meet the description above have been included in the Dangerous Goods List (Table 3-1) with the word “Forbidden” shown in columns 2 and 3. It must be noted, however, that it would be impossible to list all dangerous goods which are forbidden for transport by air under any circumstance. Therefore, it is essential that appropriate care be exercised to ensure that no goods meeting the above description are offered for transport.

Note 2.— Paragraph 2.1 is intended to include articles being returned to the manufacturer for safety reasons.

2.2 EXCEPTIONS FOR DANGEROUS GOODS OF THE OPERATOR

2.2.1 The provisions of these Instructions do not apply to the following:

- a) articles and substances which would otherwise be classified as dangerous goods but which are required to be aboard the aircraft in accordance with the pertinent airworthiness requirements and operating regulations or that are authorized by the State of the Operator to meet special requirements;
- b) aerosols, alcoholic beverages, perfumes, colognes, liquefied gas lighters and portable electronic devices containing lithium metal or lithium ion cells or batteries provided that the batteries meet the provisions of 8;1.1.2 19) carried aboard an aircraft by the operator for use or sale on the aircraft during the flight or series of flights, but excluding non-refillable gas lighters and those lighters liable to leak when exposed to reduced pressure;
- c) dry ice intended for use in food and beverage service aboard the aircraft;
- d) electronic devices, such as electronic flight bags, personal entertainment devices, and credit card readers, containing lithium metal or lithium ion cells or batteries and spare lithium batteries for such devices carried aboard an aircraft by the operator for use on the aircraft during the flight or series of flights, provided that the batteries meet the provisions of 8;1.1.2 19). Spare lithium batteries must be individually protected so as to prevent short circuits when not in use. Conditions for the carriage and use of these electronic devices and for the carriage of spare batteries must be provided in the operations manual and/or other appropriate manuals as will enable flight crew, cabin crew and other employees to carry out their responsibilities.

2.2.2 Unless otherwise authorized by the State of the Operator, articles and substances intended as replacements for those referred to in 2.2.1 a), or articles and substances referred to in 2.2.1 a) which have been removed for replacement, must be transported in accordance with the provisions of these Instructions, except that when consigned by operators, they may be carried in containers specially designed for their transport, provided such containers are capable of meeting at least the requirements for the packaging specified in these Instructions for the items packed in the containers.

2.2.3 Unless otherwise authorized by the State of the Operator, articles and substances intended as replacements for those referred to in 2.2.1 b) and c) must be transported in accordance with the provisions of these Instructions.

2.2.4 Unless otherwise authorized by the State of the Operator, battery-powered devices with installed batteries and spare batteries intended as replacements for those referred to in 2.2.1 d) must be transported in accordance with the provisions of these Instructions.

2.3 TRANSPORT OF DANGEROUS GOODS BY POST

2.3.1 In accordance with the Universal Postal Union (UPU) Convention, dangerous goods as defined in these Instructions, with the exception of those listed below, are not permitted in mail. Appropriate national authorities should ensure that the provisions are complied with in relation to the transport of dangerous goods by air.

2.3.2 The following dangerous goods may be acceptable in mail for air carriage subject to the provisions of the appropriate national authorities concerned and these Instructions which relate to such material:

- ≠ a) patient specimens as defined in 2;6.3.1.4 provided that they are classified, packed and marked as required by 2;6.3.2.3.8 a), b), c) and d);
- b) infectious substances assigned to category B (UN 3373) only, when packed in accordance with the requirements of Packing Instruction 650, and solid carbon dioxide (dry ice) when used as a refrigerant for UN 3373; and
- ≠ c) radioactive material in an excepted package, UN Nos. 2910 and 2911 only, the activity of which does not exceed one-tenth of that listed in Part 2, Chapter 7, Table 2-14, and that does not meet the definitions and criteria of classes, other than Class 7, or divisions, as defined in Part 2. The package must be marked with the name of the shipper and the consignee, the package must be marked "radioactive material — quantities permitted for movement by post" and must bear the radioactive material, excepted package label (Figure 5-31);
- d) lithium ion batteries contained in equipment (UN 3481) meeting the provisions of Section II of Packing Instruction 967. No more than four cells or two batteries may be mailed in any single package; and
- e) lithium metal batteries contained in equipment (UN 3091) meeting the provisions of Section II of Packing Instruction 970. No more than four cells or two batteries may be mailed in any single package.

2.3.3 The procedures of designated postal operators for controlling the introduction of dangerous goods in mail into air transport are subject to review and approval by the civil aviation authority of the State where the mail is accepted.

2.3.4 Before a designated postal operator can introduce the acceptance of lithium batteries as identified in 2.3.2 d) and e) they must have received specific approval from the civil aviation authority.

Note 1.— Designated postal operators may accept the dangerous goods identified in 2.3.2 a), b) and c) without receiving specific approval from the civil aviation authority.

Note 2.— Guidelines for appropriate national authorities and civil aviation authorities are contained in the Supplement to these Instructions (S-1;3).

2.4 DANGEROUS GOODS IN EXCEPTED QUANTITIES

Small quantities of dangerous goods, as defined in Part 3, Chapter 5, are excepted from certain provisions of these Instructions subject to the conditions laid down in that chapter.

2.5 EXCEPTIONS FOR DANGEROUS GOODS PACKED IN LIMITED QUANTITIES

Dangerous goods packed in limited quantities are excepted from certain provisions of these Instructions subject to the conditions laid down in Part 3, Chapter 4.

+

2.6 LAMPS CONTAINING DANGEROUS

The following lamps are not subject to these Instructions provided that they do not contain radioactive material:

- a) lamps each containing not more than 1 g of dangerous goods and packaged so that there is not more than 30 g of dangerous goods per package, provided that:
 - 1) the lamps are certified to a manufacturer's quality management system; and

Note.— The application of ISO 9001:2008 may be considered acceptable for this purpose.

-
- 2) each lamp is either individually packed in inner packagings, separated by dividers, or surrounded with cushioning material to protect the lamps and packed into strong outer packagings meeting the general provisions of 4;1.1.1 and capable of passing a 1.2 m drop test; and
 - b) lamps containing only gases of Division 2.2 (according to 2;2.2.1) provided they are packaged so that the projectile effects of any rupture of the bulb will be contained within the package.

Note.— Lamps containing radioactive material are addressed in 2;7.2.2.2 b).

Chapter 3

GENERAL INFORMATION

Parts of this Chapter are affected by State Variation BE 1; see Table A-1

3.1 DEFINITIONS

3.1.1 The following is a list of definitions of commonly used terms in these Instructions. Definitions of terms which have their usual dictionary meanings or are used in the common technical sense are not included. Definitions of additional terms used solely in conjunction with radioactive material are contained in 2;7.1.3.

Aerosols or aerosol dispensers. Non-refillable receptacles meeting the requirements of 6;3.2.7, made of metal, glass or plastic and containing a gas, compressed, liquefied or dissolved under pressure, with or without a liquid, paste or powder, and fitted with a release device allowing the contents to be ejected as solid or liquid particles in suspension in a gas, as a foam, paste or powder or in a liquid state or in a gaseous state.

Animal material. Animal carcasses, animal body parts or animal foodstuffs.

Appropriate national authority. Any authority designated, or otherwise recognized, by a State to perform specific functions related to provisions contained in these Instructions.

Approval. An authorization granted by the appropriate national authority for:

- a) the transport of dangerous goods forbidden on passenger and/or cargo aircraft where the Technical Instructions state that such goods may be carried with an approval; or
- b) other purposes as provided for in the Technical Instructions.

Note.— In the absence of a specific reference in the Technical Instructions allowing the granting of an approval, an exemption may be sought.

≠ **Approval.** For the transport of radioactive material:

Multilateral approval. The approval by the relevant competent authority of the country of origin of the design or shipment, as applicable, and also, where the consignment is to be transported through or into any other country, approval by the competent authority of that country.

Unilateral approval. The approval of a design which is required to be given by the competent authority of the country of origin of the design only.

ASTM. The American Society for Testing and Materials (ASTM International, 100 Barr Harbor Drive, PO Box C700, West Conshohocken, PA 19428-2959, United States).

Baggage. Personal property of passengers or crew carried on an aircraft by agreement with the operator.

Bags. Flexible packagings made of paper, plastic film, textiles, woven material or other suitable materials.

Boxes. Packagings with complete rectangular or polygonal faces, made of metal, wood, plywood, reconstituted wood, fibreboard, plastic or other suitable material. Small holes for purposes such as ease of handling or opening, or to meet classification requirements, are permitted as long as they do not compromise the integrity of the packaging during transport.

≠ **Bundle of cylinders.** Not permitted for air transport. An assembly of cylinders that are fastened together and which are interconnected by a manifold and transported as a unit.

Cargo. For the purposes of these Instructions, any property carried on an aircraft other than mail and accompanied or mishandled baggage.

Note.— This definition differs from the definition of “cargo” given in Annex 9 — Facilitation.

Cargo aircraft. Any aircraft, other than a passenger aircraft, which is carrying goods or property.

Cargo transport unit. A multimodal freight container or portable tank.

Closed cargo transport unit. A cargo transport unit which totally encloses the contents by permanent structures with complete and rigid surfaces. Cargo transport units with fabric sides or tops are not considered closed cargo transport units.

Closures. Devices which close an opening in a receptacle.

Combination packagings. A combination of packagings for transport purposes, consisting of one or more inner packagings secured in an outer packaging in accordance with the relevant provisions of Part 4.

Competent authority. Any body or authority designated or otherwise recognized as such for any purpose in connection with these Instructions.

Note. — *This applies to radioactive material only.*

Compliance assurance. A systematic programme of measures applied by an appropriate authority which is aimed at ensuring that the provisions of these Instructions are met in practice.

Composite packagings. Packagings consisting of an outer packaging and an inner receptacle so constructed that the inner receptacle and the outer packaging form an integral packaging. Once assembled, it remains thereafter an integrated single unit; it is filled, stored, transported and emptied as such.

Note. — *Composite packagings for the purpose of these Instructions are regarded as single packagings.*

≠ **Confinement system.** For the transport of radioactive material, the assembly of fissile material and packaging components specified by the designer and agreed to by the competent authority as intended to preserve criticality safety.

Consignee. Any person, organization or government which is entitled to take delivery of a consignment.

Consignment. One or more packages of dangerous goods accepted by an operator from one shipper at one time and at one address, receipted for in one lot and moving to one consignee at one destination address.

≠ **Containment system.** For the transport of radioactive material, the assembly of components of the packaging specified by the designer as intended to retain the radioactive material during transport.

Control temperature. The maximum temperature at which the substance can be safely transported. It is assumed that during transport the temperature of the immediate surroundings of the package does not exceed 55°C and attains this value for a relatively short time only during each period of 24 hours.

Crates. Outer packagings with incomplete surfaces.

Note. — *For air transport, crates may not be used as outer packagings of composite packagings.*

Crew member. A person assigned by an operator to duty on an aircraft during a flight duty period.

Critical temperature. The temperature above which the substance cannot exist in the liquid state.

≠ **Criticality safety index (CSI) assigned to a package, overpack or freight container containing fissile material.** For the transport of radioactive material, a number which is used to provide control over the accumulation of packages, overpacks or freight containers containing fissile material.

Cryogenic receptacle. A transportable, thermally insulated receptacle for refrigerated liquefied gases, of a water capacity of not more than 1 000 litres.

Cylinders. Transportable pressure receptacles of a water capacity not exceeding 150 litres.

Dangerous goods. Articles or substances which are capable of posing a risk to health, safety, property or the environment and which are shown in the list of dangerous goods in these Instructions, or which are classified according to these Instructions.

Dangerous goods accident. An occurrence associated with and related to the transport of dangerous goods by air which results in fatal or serious injury to a person or major property or environmental damage.

Dangerous goods incident. An occurrence, other than a dangerous goods accident, associated with and related to the transport of dangerous goods by air, not necessarily occurring on board an aircraft, which results in injury to a person, property or environmental damage, fire, breakage, spillage, leakage of fluid or radiation or other evidence that the integrity of the packaging has not been maintained. Any occurrence relating to the transport of dangerous goods which seriously jeopardizes the aircraft or its occupants is also deemed to be a dangerous goods incident.

Note. — *A dangerous goods accident or incident may also constitute an aircraft accident or incident as specified in Annex 13 — Aircraft Accident and Incident Investigation.*

Dangerous goods security. Measures or precautions to be taken by operators, shippers and others involved in the transport of dangerous goods aboard aircraft to minimize theft or misuse of dangerous goods that may endanger persons or property.

≠ **Design.** For the transport of radioactive material, the description of fissile material excepted under 2;7.2.3.5.1 f), special form radioactive material, low dispersible radioactive material, package or packaging which enables such items to be fully identified. The description may include specifications, engineering drawings, reports demonstrating compliance with regulatory requirements, and other relevant documentation.

Designated postal operator. Any governmental or non-governmental entity officially designated by a Universal Postal Union (UPU) member country to operate postal services and to fulfil the related obligations arising from the acts of the UPU Convention on its territory.

Drums. Flat-ended or convex-ended cylindrical packagings made of metal, fibreboard, plastic, plywood or other suitable materials. This definition also includes packagings of other shapes, e.g. round taper-necked packagings, or pail-shaped packagings. Jerricans are not covered by this definition.

Elevated temperature substance. A substance which is transported or offered for transport:

- in the liquid state at a temperature at or above 100°C;
- in the liquid state with a flashpoint above 60°C and which is intentionally heated to a temperature above its flashpoint; or
- in a solid state and at a temperature at or above 240°C.

EN (standard). A European standard published by the European Committee for Standardization (CEN) (CEN — 36 rue de Stassart, B-1050 Brussels, Belgium).

Exception. A provision in these Instructions which excludes a specific item of dangerous goods from the requirements normally applicable to that item.

Excess baggage. Baggage which a passenger has presented to check-in as accompanied checked baggage, but which exceeds the passenger's baggage allowance specified by the operator and which is consequently consigned as cargo in order to be sent to the same destination as the passenger.

≠ **Exclusive use.** For the transport of radioactive material, the sole use, by a single shipper, of an aircraft or of a large freight container, in respect of which all initial, intermediate and final loading and unloading and shipment are carried out in accordance with the directions of the shipper or consignee, where so required by these Instructions.

Exemption. An authorization, other than an approval, granted by an appropriate national authority providing relief from the provisions of the Technical Instructions.

Note.— The requirements for exemptions are given in 1;1.1.3.

Explosive article. An article containing one or more explosive substances.

Explosive substance. A solid or liquid substance (or a mixture of substances) which is in itself capable by chemical reaction of producing gas at such a temperature and pressure and at such a speed as to cause damage to the surroundings. Included are pyrotechnic substances even when they do not evolve gases. A substance which is not itself an explosive but which can form an explosive atmosphere of gas, vapour or dust is not included.

External carriage. Any load suspended from a helicopter or in equipment attached to a helicopter.

Filling ratio. The ratio of the mass of gas to the mass of water at 15°C that would fill completely a pressure receptacle fitted ready for use.

Flash point. The lowest temperature of a liquid at which flammable vapour is given off in a test vessel in sufficient concentration to be ignited in air when exposed momentarily to a source of ignition.

Note.— Some test methods are listed in 2;3.3.

Flight crew member. A licensed crew member charged with duties essential to the operation of an aircraft during a flight duty period.

Freight container. See unit load device.

Note.— For the definition of freight container for radioactive material, see 2;7.1.3.

≠ **Freight container in the case of radioactive material transport.** See 2;7.1.3.

Freight forwarder. A person or organization who offers the service of arranging the transport of cargo by air.

Fuel cell. An electrochemical device that converts the chemical energy of a fuel to electrical energy, heat and reaction products.

Fuel cell engine. A device used to power equipment and which consists of a fuel cell and its fuel supply, whether integrated with or separate from the fuel cell, and includes all appurtenances necessary to fulfil its function.

GHS. The fourth revised edition of the *Globally Harmonized System of Classification and Labelling of Chemicals*, published by the United Nations as document ST/SG/AC.10/30/Rev. 4.

Gross mass. The total mass of the package.

IAEA. The International Atomic Energy Agency (IAEA, P.O. Box 100 — A 1400 Vienna, Austria).

ID number. A temporary identification number for entries in Table 3-1 — Dangerous Goods List — which have not been assigned a UN number.

IEC. The International Electrotechnical Commission (IEC, 3, rue de Varembe, P.O. Box 131, CH-1211 Geneva 20, Switzerland).

IMO. The International Maritime Organization (IMO, 4 Albert Embankment, London SE1 7SR, United Kingdom).

Incompatible. Describing dangerous goods which, if mixed, would be liable to cause a dangerous evolution of heat or gas or produce a corrosive substance.

Inner packagings. Packagings for which an outer packaging is required for transport.

Inner receptacles. Receptacles which require an outer packaging in order to perform their containment function.

Inspection body. An independent inspection and testing body approved by the appropriate national authority.

Intermediate bulk containers (IBCs). Any rigid or flexible portable packaging, other than those specified in Part 6;3 of these Instructions, as described in Chapter 6.5 of the UN Model Recommendations, that is designed for mechanical handling and is resistant to the stresses produced in handling and transport, as determined by tests.

Note. — IBCs are only authorized by these Instructions for UN 3077, **Environmentally hazardous substance, solid, n.o.s.** as provided in Packing Instruction 956.

Intermediate packagings. Packagings placed between inner packagings or articles and an outer packaging.

International System of Units (SI). A rational and coherent system of units which provides the basis for the units of measurement used for air and ground operations as contained in Annex 5 to the Convention on International Civil Aviation.

ISO (standard). An international standard published by the International Organization for Standardization (ISO — 1, ch. de la Voie-Creuse, CH-1211 Geneva 20, Switzerland).

Jerricans. Metal or plastic packagings of rectangular or polygonal cross-section.

+ **Large packaging.** (Not permitted for air transport.) A packaging consisting of an outer packaging which contains articles or inner packagings and which:

- a) is designed for mechanical handling; and
- b) exceeds 400 kg net mass or 450 litres capacity but has a volume of not more than 3 m³;

+ **Large salvage packaging.** (Not permitted for air transport.) A special packaging which:

- a) is designed for mechanical handling; and
- b) exceeds 400 kg net mass or 450 litres capacity but has a volume of not more than 3 m³;

into which damaged, defective or leaking dangerous goods packages, or dangerous goods that have spilled or leaked are placed for purposes of transport for recovery or disposal.

Liner. A separate tube or bag inserted into a packaging but not forming an integral part of it, including the closures of its openings.

Liquids. Dangerous goods which at 50°C have a vapour pressure of not more than 300 kPa (3 bar), which are not completely gaseous at 20°C and at a pressure of 101.3 kPa, and which have a melting point or initial melting point of 20°C or less at a pressure of 101.3 kPa. A viscous substance for which a specific melting point cannot be determined must be subjected to the ASTM D 4359-90 test; or to the test for determining fluidity (penetrometer test) prescribed in section 2.3.4 of Annex A of the *European Agreement Concerning the International Carriage of Dangerous Goods by Road (ADR)* (United Nations publication: ECE/TRANS/202).

Low dispersible radioactive material. A solid radioactive material or a solid radioactive material in a sealed capsule, that has limited dispersibility and is not in powder form.

Mail. Dispatches of correspondence and other items tendered by, and intended for delivery to, postal services in accordance with the rules of the Universal Postal Union (UPU).

+ **Management system for the transport of radioactive material.** A set of interrelated or interacting elements (system) for establishing policies and objectives and enabling the objectives to be achieved in an efficient and effective manner.

≠ **Manual of Tests and Criteria.** The fifth revised edition of the United Nations publication entitled Recommendations on the Transport of Dangerous Goods, Manual of Tests and Criteria (ST/SG/AC.10/11/ Rev.5, Amend.1 and Amend. 2).

Maximum capacity. The maximum inner volume of receptacles or packagings expressed in litres.

Maximum net mass. The maximum net mass of contents in a single packaging or maximum combined mass of inner packagings and the contents thereof expressed in kilograms.

≠ **Maximum normal operating pressure.** For the transport of radioactive material, the maximum pressure above atmospheric pressure at mean sea level that would develop in the containment system in a period of one year under the conditions of temperature and solar radiation corresponding to environmental conditions in the absence of venting, external cooling by an ancillary system, or operational controls during transport.

Metal hydride storage system. A single complete hydrogen storage system, including a receptacle, metal hydride, pressure relief device, shut-off valve, service equipment and internal components used for the transport of hydrogen only.

Multiple-element gas containers (MEGCs). (See UN Recommendations Chapter 1.2). Not permitted for air transport.

Net explosive mass (NEM). The total mass of the explosive substances, without the packagings, casings, etc. (net explosive quantity (NEQ), net explosive contents (NEC), or net explosive weight (NEW) are often used to convey the same meaning).

≠ **Net quantity.** Either:

- a) the mass or volume of the dangerous goods contained in a package excluding the mass or volume of any packaging material; or
- b) the mass of an unpackaged article of dangerous goods (e.g. UN 3166).

For the purposes of this definition, "dangerous goods" means the substance or article as described by the proper shipping name shown in Table 3-1, e.g. for "Fire extinguishers", the net quantity is the mass of the fire extinguisher. For articles packed with equipment or contained in equipment, the net quantity is the net mass of the article, e.g. for lithium ion batteries contained in equipment, the net quantity is the net mass of the lithium ion batteries in the package.

+ **Neutron radiation detector.** A device that detects neutron radiation. In such a device, a gas may be contained in a hermetically sealed electron tube transducer that converts neutron radiation into a measureable electric signal.

Open cryogenic receptacle. A transportable thermally insulated receptacle for refrigerated liquefied gases maintained at atmospheric pressure by continuous venting of the refrigerated liquefied gas.

Operator. A person, organization or enterprise engaged in or offering to engage in an aircraft operation.

Outer packaging. The outer protection of a composite or combination packaging together with any absorbent materials, cushioning and any other components necessary to contain and protect inner receptacles or inner packagings.

Overpack. An enclosure used by a single shipper to contain one or more packages and to form one handling unit for convenience of handling and stowage.

Note.— A unit load device is not included in this definition.

Package. The complete product of the packing operation, consisting of the packaging and its contents prepared for transport.

Packaging. One or more receptacles and any other components or materials necessary for the receptacles to perform their containment and other safety functions.

Note.— For radioactive material, see 2;7.1.3.

Passenger aircraft. An aircraft that carries any person other than a crew member, an operator's employee in an official capacity, an authorized representative of an appropriate national authority or a person accompanying a consignment or other cargo.

Pilot-in-command. The pilot designated by the operator, or in the case of general aviation, the owner, as being in command and charged with the safe conduct of a flight.

Portable tanks. For the definition of portable tanks, see Part S-4, Chapter 12 of the Supplement.

Pressure drums. (See UN Recommendations, Chapter 1.2). Not permitted for air transport.

Pressure receptacle. A collective term that includes cylinders, tubes, pressure drums, closed cryogenic receptacles, metal hydride storage systems, bundles of cylinders and salvage pressure receptacles.

Pyrotechnic substance. A mixture or compound designed to produce an effect by heat, light, sound, gas or smoke or a combination of these as the result of non-detonative, self-sustaining, exothermic, chemical reactions.

Quality assurance. A systematic programme of controls and inspections applied by any organization or body which is aimed at providing adequate confidence that the standard of safety prescribed by these Instructions is achieved in practice.

+ **Radiation detection system.** An apparatus that contains radiation detectors as components.

≠ **Radiation level.** For the transport of radioactive material, the corresponding dose rate expressed in millisieverts per hour or microsieverts per hour.

≠ **Radioactive contents.** For the transport of radioactive material, the radioactive material together with any contaminated or activated solids, liquids, and gases within the packaging.

Receptacles. Containment vessels for receiving and holding substances or articles, including any means of closing.

Reconditioned packagings include:

a) metal drums that are:

- i) cleaned to original materials of construction, with all former contents, internal and external corrosion, and external coatings and labels removed;
- ii) restored to original shape and contour, with chimes (if any) straightened and sealed, and all non-integral gaskets replaced; and
- iii) inspected after cleaning but before painting, with rejection of packagings with visible pitting, significant reduction in material thickness, metal fatigue, damaged threads or closures, or other significant defects;

b) plastic drums and jerricans that:

- i) are cleaned to original materials of construction, with all former contents, external coatings and labels removed;
- ii) have all non-integral gaskets replaced; and
- iii) are inspected after cleaning with rejection of packagings with visible damage such as tears, creases or cracks, or damaged threads or closures or other significant defects.

Note.— It is anticipated that further examples will be added in future.

Recycled plastic material. Material recovered from used industrial packagings that has been cleaned and prepared for processing into new packagings. The specific properties of the recycled material used for production of new packagings must be assured and documented regularly as part of a quality assurance programme recognized by the appropriate national authority. The quality assurance programme must include a record of proper pre-sorting and verification that each batch of recycled plastic material has the proper melt flow rate, density, and tensile yield strength, consistent with that of the design type manufactured from such recycled material. This necessarily includes knowledge about the packaging material from which the recycled plastic has been derived, as well as awareness of the prior contents of those packagings if those prior contents might reduce the capability of new packagings produced using that material. In addition, the packaging manufacturer's quality assurance programme must include performance of the mechanical design type test in Part 6, Chapter 4 on packagings manufactured from each batch of recycled plastic material. In this testing, stacking performance may be verified by appropriate dynamic compression testing rather than static load testing.

Note.— ISO 16103:2005 "Packaging — Transport packages for dangerous goods — Recycled plastics material", provides additional guidance on procedures to be followed in approving the use of recycled plastics material.

Remanufactured large packaging. (See UN Recommendations, Chapter 1.2). Not permitted for air transport.

Remanufactured packagings include:

a) metal drums that:

- i) are produced as a UN type from a non-UN type;
- ii) are converted from one UN type to another UN type; or
- iii) undergo the replacement of integral structural components (such as non-removable heads);

- b) plastic drums that:
 - i) are converted from one UN type to another UN type (e.g. 1H1 to 1H2); or
 - ii) undergo the replacement of integral structural components.

Remanufactured drums are subject to the same requirements of these Instructions as apply to a new drum of the same type.

Reused large packaging. (See UN Recommendations, Chapter 1.2). Not permitted for air transport.

Reused packagings. Packagings to be refilled which have been examined and found free of defects affecting the ability to withstand the performance tests; the term includes those which are refilled with the same or similar compatible contents and are transported within distribution chains controlled by the shipper of the product.

Salvage packagings. Special packagings into which damaged, defective, leaking or nonconforming dangerous goods packages, or dangerous goods that have spilled or leaked, are placed for purposes of transport for recovery or disposal.

Salvage pressure receptacle. (See UN Recommendations, Chapter 1.2). Not permitted for air transport.

Self-accelerating decomposition temperature (SADT). The lowest temperature at which self-accelerating decomposition may occur with a substance in the packaging as used in transport.

Serious injury. An injury which is sustained by a person in an accident and which:

- a) requires hospitalization for more than 48 hours, commencing within seven days from the date the injury was received; or
- b) results in a fracture of any bone (except simple fractures of fingers, toes or nose); or
- c) involves lacerations which cause severe haemorrhage, nerve, muscle or tendon damage; or
- d) involves injury to any internal organ; or
- e) involves second or third degree burns, or any burns affecting more than 5 per cent of the body surface; or
- f) involves verified exposure to infectious substances or injurious radiation.

Settled pressure. The pressure of the contents of a pressure receptacle in thermal and diffusive equilibrium.

Shipment. The specific movement of a consignment from origin to destination.

Siftproof packagings. Packagings impermeable to dry contents including fine solid material produced during transport.

Single packagings. Packagings which do not require any inner packaging to perform their containment function during transport.

Solid dangerous goods. Dangerous goods, other than gases, that do not meet the definition of Liquid dangerous goods.

State of Destination. The State in the territory of which the consignment is finally to be unloaded from an aircraft.

State of Origin. The State in the territory of which the consignment is first to be loaded on an aircraft.

State of Registry. The State on whose register the aircraft is entered.

State of the Operator. The State in which the operator's principal place of business is located or, if there is no such place of business, the operator's permanent residence.

≠ **Stores (supplies).** a) Stores (supplies) for consumption; and b) Stores (supplies) to be taken away.

Stores (supplies) for consumption. Goods, whether or not sold, intended for consumption by the passengers and the crew on board aircraft, and goods necessary for the operation and maintenance of aircraft, including fuel and lubricants.

Stores (supplies) to be taken away. Goods for sale to the passengers and the crew of aircraft with a view to being landed.

Items that meet the classification as dangerous goods and which are transported in accordance with Part 1;2.2.2, Part 1;2.2.3 or Part 1;2.2.4 are considered as "cargo".

Tank. A tank container, portable tank, a road tank-vehicle, a rail tank-wagon or a receptacle intended to contain solids, liquids, or gases and has a capacity of not less than 450 litres when used for the transport of gases as defined in 2;2.1.1.

Note. — These Technical Instructions do not permit the use of a tank for the transport of radioactive material by air.

Test pressure. The required pressure applied during a pressure test for qualification or re-qualification.

≠ **Transport index (TI) assigned to a package, overpack or freight container.** For the transport of radioactive material, a number which is used to provide control over radiation exposure.

≠ **Through or into.** For the transport of radioactive material, through or into the countries in which a consignment is transported but specifically excluding countries “over” which a consignment is carried by air, provided that there are no scheduled stops in those countries.

UNECE. The United Nations Economic Commission for Europe (UNECE, Palais des Nations, 8-14 avenue de la Paix, CH-1211 Geneva 10, Switzerland).

Unit load device. Any type of freight container, aircraft container, aircraft pallet with a net or aircraft pallet with a net over an igloo.

Note 1.— An overpack is not included in this definition.

Note 2.— A freight container for radioactive material is not included in this definition (see 2;7.1.3).

UN number. The four-digit number assigned by the United Nations Committee of Experts on the Transport of Dangerous Goods to identify a substance or a particular group of substances.

Working pressure. The settled pressure of a compressed gas at a reference temperature of 15°C in a full pressure receptacle.

3.1.2 Clarifying examples for certain defined terms

The following explanations and examples are meant to assist in clarifying the use of some of the packaging terms defined in this section.

The definitions in this section are consistent with the use of defined terms throughout the Instructions. However, some of the defined terms are commonly used in other ways. This is particularly evident in respect of the term “inner receptacle” which has often been used to describe the “inners” of a combination packaging.

The “inners” of “combination packagings” are always termed “inner packagings” not “inner receptacles”. A glass bottle is an example of such an “inner packaging”.

The “inners” of “composite packagings” are normally termed “inner receptacles”. For example, the “inner” of a 6HA1 composite packaging (plastic material) is such an “inner receptacle” since it is normally not designed to perform a containment function without its “outer packaging” and is therefore not an “inner packaging”.

3.2 UNITS OF MEASUREMENT AND CONVERSION FACTORS

3.2.1 Units of measurement

The units of measurement to be used in the transport of dangerous goods by air are those specified by the International System (SI) as modified for international civil aviation by Annex 5 to the Chicago Convention. The primary units of mass and volume will be the kilogram (kg) and the litre (L) and the unit of pressure will be the kilopascal (kPa). Except as specifically provided for in these Technical Instructions, only those abbreviations for units of measurement that are indicated in this paragraph, or in Annex 5 to the Chicago Convention, may be used in the transport of dangerous goods by air.

Note.— Where measurements relating to radioactivity occur in these Instructions, the value is given in SI units followed, in parentheses, by the non-SI equivalent.

3.2.2 Non-SI equivalents

It is recognized that there are in existence many packagings which were designed and constructed for use with non-SI quantity limitations and that such packagings will continue to be used for some time to come. Table 1-1 therefore contains a list of authorized non-SI equivalents for quantity limitations expressed in SI units. It is stressed that these are not precise equivalents but are nevertheless acceptable based upon the likely availability of packaging.

3.2.3 Conversion factors

Precise conversion factors for commonly used SI units are given in Annex 5 to the Chicago Convention. Tables 1-2 and 1-3 show conversion factors, to four significant figures, for some units widely used in dangerous goods transport.

Table 1-1. Authorized equivalents

Volume		
Litres	Imperial	U.S.
0.5	1 pt	1 pt
1	1 qt	1 qt
2	2 qt	2 qt
2.5	5 pt	5 pt
5	1 gal	1.25 gal
10	2 gal	2.5 gal
15	3 gal	3.75 gal
20	4.25 gal	5 gal
25	5.5 gal	6.25 gal
30	6.5 gal	7.5 gal
42	9 gal	11 gal
50	11 gal	13 gal
60	13 gal	15 gal
100	22 gal	25 gal
120	26 gal	30 gal
220	48 gal	55 gal
250	55 gal	62.5 gal

Note.— Where quantities are specified in SI units of mass, for 500 kg or less, quantities expressed in pounds may be substituted on the basis of one pound per 500 grams.

Table 1-2. Conversion to SI units*

To convert	to	Multiply by
bar	kilopascals (kPa)	100.0
curie (Ci)	gigabecquerel (GBq)	37.00
degrees Fahrenheit	degrees Celsius (°C)	subtract 32°F and multiply by 5/9
feet	metres (m)	0.304 8
gallons (Imperial)	litres (L)	4.546
gallons (U.S. liquid)	litres (L)	3.785
inches	millimetres (mm)	25.40
kilogram-force (kgf)	newton (N)	9.807
kilograms per square centimetre	kilopascals (kPa)	98.07
oersted	amperes per metre (A/m)	79.58
ounces, fluid (Imperial)	millilitres (mL)	28.41
ounces, fluid (U.S.)	millilitres (mL)	29.57
pints (Imperial)	litres (L)	0.568 3
pints (U.S.)	litres (L)	0.473 2
pounds (avoirdupois)	kilograms (kg)	0.453 6
pounds per square inch	kilopascals (kPa)	6.895
quarts (Imperial)	litres (L)	1.137
quarts (U.S.)	litres (L)	0.946 4
rad	gray (Gy)	0.010 00
rem	sievert (Sv)	0.010 00

Table 1-3. Conversion from SI units*

<i>To convert</i>	<i>to</i>	<i>Multiply by</i>
amperes per metre (A/m)	oersted	0.012 57
degrees Celsius (°C)	degrees Fahrenheit	multiply by 9/5 and add 32°F
gray (Gy)	rad	100.0
kilograms (kg)	pounds	2.205
kilopascals (kPa)	bar	0.010 00
kilopascals (kPa)	kilograms per square centimetre	0.010 20
kilopascals (kPa)	pounds per square inch	0.145 0
litres (L)	gallons (Imperial)	0.220 0
litres (L)	gallons (U.S. liquid)	0.264 2
litres (L)	pints (Imperial)	1.760
litres (L)	pints (U.S.)	2.113
litres (L)	quarts (Imperial)	0.879 9
litres (L)	quarts (U.S.)	1.057
metres (m)	feet	3.281
millilitres (mL)	ounces, fluid (Imperial)	0.035 20
millilitres (mL)	ounces, fluid (U.S.)	0.033 81
millimetres (mm)	inches	0.039 37
newton (N)	kilogram-force (kgf)	0.1020
sievert (Sv)	rem	100.0
terabecquerel (TBq)	curie (Ci)	27.03

* Where a prefix is used, it indicates a multiplying factor as follows:

tera (T)	$\times 10^{12}$
giga (G)	$\times 10^9$
mega (M)	$\times 10^6$
kilo (k)	$\times 10^3$
milli (m)	$\times 10^{-3}$
micro (μ)	$\times 10^{-6}$
nano (n)	$\times 10^{-9}$

INTRODUCTORY NOTE

The successful application of regulations concerning the transport of dangerous goods and the achievement of their objectives are greatly dependent on the appreciation by all individuals concerned of the risks involved and on a detailed understanding of the regulations. This can only be achieved by properly planned and maintained initial and recurrent training programmes in the transport of dangerous goods for all persons concerned.

Chapter 4

TRAINING

*Parts of this Chapter are affected by State Variations AE 2, BR 7, CA 11, HK 1;
see Table A-1*

4.1 ESTABLISHMENT OF TRAINING PROGRAMMES

4.1.1 Initial and recurrent dangerous goods training programmes must be established and maintained by or on behalf of:

- a) shippers of dangerous goods, including packers and persons or organizations undertaking the responsibilities of the shipper;
- b) operators;
- ≠ c) ground handling agencies which perform, on behalf of the operator, the act of accepting, handling, loading, unloading, transferring or other processing of cargo or mail;
- d) ground handling agencies located at an airport which perform, on behalf of the operator, the act of processing passengers;
- e) agencies, not located at an airport, which perform, on behalf of the operator, the act of checking in passengers;
- f) freight forwarders;
- ≠ g) agencies engaged in the security screening of passengers and crew and their baggage and/or cargo or mail; and
- h) designated postal operators.

4.1.2 Dangerous goods training programmes required by 4.1.1 b) must be subjected to review and approval by the appropriate authority of the State of the Operator. Dangerous goods training programmes required by 4.1.1 h) must be subjected to review and approval by the civil aviation authority of the State where the mail was accepted by the designated postal operator. Dangerous goods training programmes required by other than 4.1.1 b) and h) should be subjected to review and approval as determined by the appropriate national authority.

4.2 TRAINING CURRICULA

4.2.1 Personnel must be trained in the requirements commensurate with their responsibilities. Such training must include:

- a) general familiarization training — which must be aimed at providing familiarity with the general provisions;
- b) function-specific training — which must provide detailed training in the requirements applicable to the function for which that person is responsible; and
- c) safety training — which must cover the hazards presented by dangerous goods, safe handling and emergency response procedures.

4.2.2 Personnel identified in the categories specified in Table 1-4, 1-5 or 1-6 must be trained or training must be verified prior to the person performing any duty specified in Table 1-4, 1-5 or 1-6.

4.2.3 Recurrent training must be provided within 24 months of previous training to ensure knowledge is current. However, if recurrent training is completed within the final three months of validity of previous training, the period of validity extends from the month on which the recurrent training was completed until 24 months from the expiry month of that previous training.

4.2.4 A test to verify understanding must be provided following training. Confirmation that the test has been completed satisfactorily is required.

4.2.5 A record of training must be maintained which must include:

- a) the individual's name;
- b) the most recent training completion month;
- c) a description, copy or reference to training materials used to meet the training requirements;
- d) the name and address of the organization providing the training; and
- e) evidence which shows that a test has been completed satisfactorily.

Training records must be retained by the employer for a minimum period of 36 months from the most recent training completion month and must be made available upon request to the employee or appropriate national authority.

4.2.6 The subject matter relating to dangerous goods transport with which various categories of personnel should be familiar is indicated in Table 1-4.

4.2.7 Staff of operators not carrying dangerous goods as cargo or mail must be trained commensurate with their responsibilities. The subject matter to which their various categories of staff should be familiar with is indicated in Table 1-5.

Note.— Security staff are required to be trained irrespective of whether the operator on which passenger or cargo is to be transported carries dangerous goods as cargo.

Table 1-4. Content of training courses

#	<i>Shippers and packers</i>		<i>Freight forwarders</i>			<i>Operators and ground handling agents</i>						<i>Security staff</i>
	1	2	3	4	5	<i>Categories of staff</i>						12
<i>Aspects of transport of dangerous goods by air with which they should be familiar, as a minimum</i>						6	7	8	9	10	11	12
General philosophy	x	x	x	x	x	x	x	x	x	x	x	x
Limitations	x		x	x	x	x	x	x	x	x	x	x
General requirements for shippers	x		x			x						
Classification	x	x	x			x						x
List of dangerous goods	x	x	x			x				x		
Packing requirements	x	x	x			x						
Labelling and marking	x	x	x	x	x	x	x	x	x	x	x	x
Dangerous goods transport document and other relevant documentation	x		x	x		x	x					
Acceptance procedures						x						
Recognition of undeclared dangerous goods	x	x	x	x	x	x	x	x	x	x	x	x
Storage and loading procedures					x	x		x		x		
Pilots' notification						x		x		x		
Provisions for passengers and crew	x	x	x	x	x	x	x	x	x	x	x	x
Emergency procedures	x	x	x	x	x	x	x	x	x	x	x	x

CATEGORIES

- 1 — Shippers and persons undertaking the responsibilities of shippers
- 2 — Packers
- 3 — Staff of freight forwarders involved in processing dangerous goods
- 4 — Staff of freight forwarders involved in processing cargo or mail (other than dangerous goods)
- 5 — Staff of freight forwarders involved in the handling, storage and loading of cargo or mail
- 6 — Operator's and ground handling agent's staff accepting dangerous goods

- 7 — Operator's and ground handling agent's staff accepting cargo or mail (other than dangerous goods)
- 8 — Operator's and ground handling agent's staff involved in the handling, storage and loading of cargo or mail and baggage
- 9 — Passenger handling staff
- ≠ 10 — Flight crew members, loadmasters, load planners and flight operations officers/flight dispatchers
- 11 — Crew members (other than flight crew members)
- ≠ 12 — Security staff who are involved with the screening of passengers and crew and their baggage and cargo or mail, e.g. security screeners, their supervisors and staff involved in implementing security procedures

Table 1-5. Content of training courses for operators not carrying dangerous goods as cargo or mail

≠	Contents	Categories of staff				
		13	14	15	16	17
	General philosophy	X	X	X	X	X
	Limitations	X	X	X	X	X
	Labelling and marking	X	X	X	X	X
	Dangerous goods transport document and other relevant documentation	X				
	Recognition of undeclared dangerous goods	X	X	X	X	X
	Provisions for passengers and crew	X	X	X	X	X
	Emergency procedures	X	X	X	X	X

≠ CATEGORIES

- ≠ 13 — Operator's and ground handling agent's staff accepting cargo or mail (other than dangerous goods)
- ≠ 14 — Operator's and ground handling agent's staff involved in the handling, storage and loading of cargo or mail (other than dangerous goods) and baggage
- ≠ 15 — Passenger handling staff
- ≠ 16 — Flight crew members, loadmasters, load planners and flight operations officers/flight dispatchers
- ≠ 17 — Crew members (other than flight crew members)

Note 1.— Depending on the responsibilities of the person, the aspects of training to be covered may vary from those shown in Tables 1-4 and 1-5. For example, in respect of classification, staff involved in implementing security procedures (e.g. screeners and their supervisors) need only be trained in the general properties of dangerous goods.

Note 2.— The categories of personnel identified in Tables 1-4 and 1-5 are not all encompassing. Personnel employed by or interacting with the aviation industry in areas such as passenger and cargo reservation centres, and engineering and maintenance, except when acting in a capacity identified in Table 1-4 or 1-5, should be provided with dangerous goods training in accordance with 4.2.

4.2.8 Staff of designated postal operators must be trained commensurate with their responsibilities. The subject matter to which their various categories of staff should be familiar with is indicated in Table 1-6.

4.3 INSTRUCTOR QUALIFICATIONS

4.3.1 Unless otherwise provided for by the appropriate national authority, instructors of initial and recurrent dangerous goods training programmes must have adequate instructional skills and have successfully completed a dangerous goods training programme in the applicable category, or Category 6, prior to delivering such a dangerous goods training programme.

4.3.2 Instructors delivering initial and recurrent dangerous goods training programmes must at least every 24 months deliver such courses, or in the absence of this attend recurrent training.

Table 1-6. Content of training courses for staff of designated postal operators

Aspects of transport of dangerous goods by air with which they should be familiar, as a minimum	Designated postal operators		
	Categories of staff		
	A	B	C
General philosophy	x	x	x
Limitations	x	x	x
General requirements for shippers	x		
Classification	x		
List of dangerous goods	x		
Packing requirements	x		
Labelling and marking	x	x	x
Dangerous goods transport document and other relevant documentation	x	x	
Acceptance of the dangerous goods listed in 1;2.3.2	x		
Recognition of undeclared dangerous goods	x	x	x
Storage and loading procedures			x
Provisions for passengers and crew	x	x	x
Emergency procedures	x	x	x

≠ **CATEGORIES**

- A — Staff of designated postal operators involved in accepting mail containing dangerous goods
 B — Staff of designated postal operators involved in processing mail (other than dangerous goods)
 C — Staff of designated postal operators involved in the handling, storage and loading of mail

Note.— Guidance on the aspects of training to be covered by staff of designated postal operators can be found in S-1;3.

4.4 COMPETENCY-BASED TRAINING AND ASSESSMENT

Competency-based training and assessment should be used in accordance with the general provisions contained in Chapter 2 of the *Procedures for Air Navigation Services — Training* (PANS-TRG, Doc 9868).

Chapter 5

DANGEROUS GOODS SECURITY

Parts of this Chapter are affected by State Variation RU 2, US 17; see Table A-1

Note.— This Chapter addresses the security responsibilities of operators, shippers and others involved in the transport of dangerous goods aboard aircraft. It should be noted that Annex 17 — Security, provides comprehensive requirements for implementation of security measures by States to prevent unlawful interference with civil aviation or when such interference has been committed. In addition, the Security Manual for Safeguarding Civil Aviation against Acts of Unlawful Interference (Doc 8973 — Restricted) provides procedures and guidance on aspects of aviation security and is intended to assist States in the implementation of their respective national civil aviation security programmes. The requirements in the Chapter are intended to supplement the requirements of Annex 17 and to implement measures to be taken to minimize theft or misuse of dangerous goods that may endanger persons or property. The provisions of this Chapter do not supersede requirements of Annex 17 or the Security Manual.

5.1 GENERAL SECURITY PROVISIONS

5.1.1 All persons engaged in the transport of dangerous goods should consider security requirements for the dangerous goods commensurate with their responsibilities.

5.1.2 Dangerous goods should only be offered to operators that have been appropriately identified.

5.1.3 The provisions of this chapter do not apply to:

- a) UN 2908 and UN 2909 excepted packages;
- b) UN 2910 and UN 2911 excepted packages with an activity level not exceeding the A₂ value; and
- c) UN 2912 LSA-I and UN 2913 SCO-I.

5.2 DANGEROUS GOODS SECURITY TRAINING

5.2.1 The training specified in 4.2 should include elements of security awareness.

5.2.2 Security awareness training should address the nature of security risks, recognizing security risks methods to address and reduce such risks, and actions to be taken in the event of a security breach. It should include awareness of security plans (if appropriate) commensurate with the responsibilities of individuals and their part in implementing security plans.

Note.— Persons who have received security training in accordance with the requirements of a national security plan or other security requirements that fulfil the elements of 5.2.2 need not receive additional training.

5.2.3 Such training should be provided or verified upon employment in a position involving dangerous goods transport. Recurrent training should take place within 24 months of previous training to ensure knowledge is current.

5.2.4 Records of all dangerous goods security training undertaken should be kept by the employer and made available to the employee or appropriate national authority upon request. Records should be kept by the employer for a period of time established by the appropriate national authority.

5.3 PROVISIONS FOR HIGH CONSEQUENCE DANGEROUS GOODS

5.3.1 Definition of high consequence dangerous goods

5.3.1.1 High consequence dangerous goods are those which have the potential for misuse in a terrorist event and which may, as a result, produce serious consequences such as mass casualties, mass destruction or, particularly for Class 7, mass socio-economic disruption.

5.3.1.2 An indicative list of high consequence dangerous goods in classes and divisions other than Class 7 is given in Table 1-7.

Table 1-7. Indicative list of high consequence dangerous goods

Class 1 Division 1.1 explosives
Class 1 Division 1.2 explosives
Class 1 Division 1.3 compatibility group C explosives
Class 1 Division 1.4 UN Nos. 0104, 0237, 0255, 0267, 0289, 0361, 0365, 0366, 0440, 0441, 0455, 0456 and 0500
Class 1 Division 1.5 explosives
Division 2.3 toxic gases (excluding aerosols)
Class 3 desensitized explosives
Division 4.1 desensitized explosives
Division 6.1 substances of Packing Group 1; except when transported under the excepted quantity provisions in 3;5
Division 6.2 infectious substances of Category A (UN Nos. 2814 and 2900)

5.3.1.3 For dangerous goods of Class 7, high consequence radioactive material is that with an activity equal to or greater than a transport security threshold of 3 000 A₂ per single package (see also 2;7.2.2.1) except for the following radionuclides where the transport security threshold is given in Table 1-8 below.

Table 1-8. Transport security thresholds for specific radionuclides

<i>Element</i>	<i>Radionuclide</i>	<i>Transport security threshold (TBq)</i>
Americium	Am-241	0.6
Gold	Au-198	2
Cadmium	Cd-109	200
Californium	Cf-252	0.2
Curium	Cm-244	0.5
Cobalt	Co-57	7
Cobalt	Co-60	0.3
Caesium	Cs-137	1
Iron	Fe-55	8000
Gadolinium	Gd-153	10
Germanium	Ge-68	7
Iridium	Ir-192	0.8
Nickel	Ni-63	600
Palladium	Pd-103	900
Promethium	Pm-147	400
Polonium	Po-210	0.6
Plutonium	Pu-238	0.6
Plutonium	Pu-239	0.6

<i>Element</i>	<i>Radionuclide</i>	<i>Transport security threshold (TBq)</i>
Radium	Ra-226	0.4
Ruthenium	Ru-106	3
Selenium	Se-75	2
Strontium	Sr-90	10
Thallium	Tl-204	200
Thulium	Tm-170	200
Ytterbium	Yb-169	3

5.3.1.4 For mixtures of radionuclides, determination of whether or not the transport security threshold has been met or exceeded can be calculated by summing the ratios of activity present for each radionuclide divided by the transport security threshold for that radionuclide. If the sum of the fractions is less than 1, then the radioactivity threshold for the mixture has not been met nor exceeded.

This calculation can be made with the formula:

$$\sum_i \frac{A_i}{T_i} < 1$$

Where:

A_i = activity of radionuclide i that is present in a package (TBq)

T_i = transport security threshold for radionuclide i (TBq).

5.3.1.5 When radioactive material possess subsidiary risks of other classes or divisions, the criteria of Table 1-7 should also be taken into account (see also 1;6.5).

5.4 SECURITY PLANS

5.4.1 Operators, shippers and others (including infrastructure managers) engaged in the transport of high consequence dangerous goods (see 5.3.1) should adopt, implement and comply with a security plan that addresses at least the elements specified in 5.4.2.

Note.— When national authorities issue exemptions, they should consider all of the provisions in this Chapter.

5.4.2 The security plan should comprise at least the following elements:

- a) specific allocation of responsibilities for security to competent and qualified persons with appropriate authority to carry out their responsibilities;
- b) records of dangerous goods or types of dangerous goods transported;
- c) review of current operations and assessment of vulnerabilities, including inter-modal transfer, temporary transit storage, handling, and distribution, as appropriate;
- d) clear statement of measures including training policies (including response to higher threat conditions, new employee/employment verifications, etc.), operating practices (e.g. access to dangerous goods in temporary storage proximity to vulnerable infrastructure, etc.), equipment and resources that are to be used to reduce security risks;
- e) effective and up-to-date procedures for reporting and dealing with security threats, breaches of security or security incidents;
- f) procedures for the evaluation and testing of security plans and procedures for periodic review and update of the plans;
- g) measures to ensure the security of transport information contained in the plan; and
- h) measures to ensure that the security of the distribution of transport documentation is limited as far as possible. (Such measures must not preclude provision of the transport documentation required by Part 5, Chapter 4 of these Instructions.)

Note.— Operators, shippers and others with responsibilities for the safe and secure transport of dangerous goods should cooperate with each other and with appropriate authorities to exchange threat information, apply appropriate security measures and respond to security incidents.

5.5 RADIOACTIVE MATERIAL

For radioactive material, the provisions of this Chapter are deemed to be complied with when the provisions of the Convention on Physical Protection of Nuclear Material¹ and the IAEA circular on "The Physical Protection of Nuclear Material and Nuclear Facilities"² are applied.

1. INFCIRC/274/Rev.1, IAEA, Vienna (1980).

2. INFCIRC/225/Rev.4 (Corrected), IAEA, Vienna (1999).

Chapter 6

≠ GENERAL PROVISIONS CONCERNING RADIOACTIVE MATERIAL

Parts of this Chapter are affected by State Variations BR 8, JP 3, JP 23; see Table A-1

6.1 SCOPE AND APPLICATION

≠ 6.1.1 These Instructions establish standards of safety which provide an acceptable level of control of the radiation, criticality and thermal hazards to persons, property and the environment that are associated with the transport of radioactive material. These Instructions are based on the IAEA *Regulations for the Safe Transport of Radioactive Material*, (2012 Edition), IAEA Safety Standards Series No. SSR-6, IAEA, Vienna (2012). Explanatory material can be found in *Advisory Material for the IAEA Regulations for the Safe Transport of Radioactive Material*, Safety Standard Series No. TS-G-1.1 (Rev. 1), IAEA, Vienna (2008). The prime responsibility for safety must rest with the person or organization responsible for facilities and activities that give rise to radiation risk.

6.1.2 The objective of these Instructions is to establish requirements that must be satisfied to ensure safety and to protect persons, property and the environment from the effects of radiation in the transport of radioactive material. This protection is achieved by requiring:

- a) containment of the radioactive contents;
- b) control of external radiation levels;
- c) prevention of criticality; and
- d) prevention of damage caused by heat.

≠ These requirements are satisfied firstly by applying a graded approach to the limits of the contents for packages and aircraft and to the performance standards, which are applied to package designs depending upon the hazard of the radioactive contents. Secondly, they are satisfied by imposing conditions on the design and operation of packages and on the maintenance of the packagings, including consideration of the nature of the radioactive contents. Finally, they are satisfied by requiring administrative controls including, where appropriate, approval by competent authorities.

6.1.3 These Instructions apply to the transport of radioactive material by air, including transport that is incidental to the use of the radioactive material. Transport comprises all operations and conditions associated with and involved in the movement of radioactive material; these include the design, manufacture, maintenance and repair of packaging, and the preparation, consigning, loading, carriage including in-transit storage, unloading and receipt at the final destination of the radioactive material and packages. A graded approach is applied to the performance standards in these Instructions that are characterized by three general severity levels:

- a) routine conditions of transport (incident free);
- b) normal conditions of transport (minor mishaps); and
- c) accident conditions of transport.

≠ 6.1.4 These Instructions do not apply to any of the following:

- a) radioactive material implanted or incorporated into a person or live animal for diagnosis or treatment;

≠ b) radioactive material in or on a person who is to be transported for medical treatment because the person has been subject to accidental or deliberate intake of or contamination from radioactive material, taking into account the necessary radiological protection measures with respect to other passengers and crew, subject to approval by the operator;

≠ *Note.*— *Guidance material may be found on www.icao.int/safety/DangerousGoods/Pages/Guidance-Material.aspx.*

- c) radioactive material in consumer products which have received regulatory approval, following their sale to the end user;

- ≠ d) natural material and ores containing naturally occurring radionuclides (which may have been processed), provided the activity concentration of the material does not exceed 10 times the values specified in Table 2-12 or calculated in accordance with 2;7.2.2.2 a) and 2;7.2.2.3 to 2;7.2.2.6. For natural materials and ores containing naturally occurring radionuclides that are not in secular equilibrium, the calculation of the activity concentration must be performed in accordance with 2;7.2.2.4;
- e) non-radioactive solid objects with radioactive substances present on any surfaces in quantities not in excess of the limit specified in the definition of contamination in 2;7.1.

6.1.5 Specific provisions for the transport of excepted packages

- ≠ 6.1.5.1 Excepted packages which may contain radioactive material as specified in 2;7.2.4.1.1 are subject only to the following provisions of Parts 5 to 7:
 - ≠ a) the applicable provisions specified in 5;1.1 (as applicable), 5;1.2.2.2, 5;1.2.2.3, 5;1.2.4, 5;1.4, 5;1.6.3, 5;2.2, 5;2.4.10, 5;3.2.12 e), 5;3.3, 5;4.4, 7;1.6, 7;2.5, 7;2.9.3.1, 7;3.2.1, 7;3.2.4, 7;4.4 and 7;4.5; and
 - ≠ b) the requirements for excepted packages specified in 6;7.3;
- + except when the radioactive material possesses other hazardous properties and has to be classified in a class other than Class 7 in accordance with Special Provision A130 or A194, where the provisions listed in a) and b) above apply only as relevant and in addition to those relating to the main class or division.
- >
- ≠ 6.1.5.2 Excepted packages are subject to the relevant provisions of all other parts of these Instructions. If the excepted package contains fissile material, one of the fissile exceptions provided in 2;7.2.3.5 must apply and the requirements of 7;2.9.4.3 must be met.

6.2 RADIATION PROTECTION PROGRAMME

6.2.1 The transport of radioactive material must be subject to a radiation protection programme, which must consist of systematic arrangements aimed at providing adequate consideration of radiation protection measures.

- ≠ 6.2.2 Doses to persons must be below the relevant dose limits. Protection and safety must be optimized in order that the magnitude of individual doses, the number of persons exposed and the likelihood of incurring exposure must be kept as low as reasonably achievable, economic and social factors being taken into account, within the restriction that the doses to individuals are subject to dose constraints. A structured and systematic approach must be adopted and must include consideration of the interfaces between transport and other activities.

6.2.3 The nature and extent of the measures to be employed in the programme must be related to the magnitude and likelihood of radiation exposure. The programme must incorporate the requirements in 6.2.2 and 6.2.4 to 6.2.7, 7;2.9.1.1 and 7;2.9.1.2. Programme documents must be available, on request, for inspection by the relevant competent authority.

- ≠ 6.2.4 For occupational exposure arising from transport activities, where it is assessed that the effective dose either:
 - ≠ a) is likely to be between 1 and 6 mSv in a year, a dose assessment programme via workplace monitoring or individual monitoring must be conducted; or
 - b) is likely to exceed 6 mSv in a year, individual monitoring must be conducted.

When individual monitoring or workplace monitoring is conducted, appropriate records must be kept.

Note.— For occupational exposure arising from transport activities, where it is assessed that the effective dose is most unlikely to exceed 1 mSv in a year, no special work patterns, detailed monitoring, dose assessment programmes or individual record-keeping need be required.

- ≠ 6.2.5 In the event of accidents or incidents during the transport of radioactive material, emergency provisions, as established by relevant national and/or international organizations, must be observed to protect persons, property and the environment. Appropriate guidelines for such provisions are contained in "Planning and Preparing for Emergency Response to Transport Accidents Involving Radioactive Material", IAEA Safety Standard Series No. TS-G-1.2 (ST-3), IAEA, Vienna (2002).

6.2.6 Emergency procedures must take into account the formation of other dangerous substances that may result from the reaction between the contents of a consignment and the environment in the event of an accident.

6.2.7 Personnel must be appropriately trained in the radiation hazards involved and the precautions to be observed in order to ensure restriction of their exposure and that of other persons who might be affected by their actions.

#

6.3 MANAGEMENT SYSTEM

A management system based on international, national or other standards acceptable to the competent authority must be established and implemented for all activities within the scope of the Instructions, as identified in 1;6.1.3, to ensure compliance with the relevant provisions of these Instructions. Certification that the design specification has been fully implemented must be available to the competent authority. The manufacturer, shipper or user must be prepared to:

- a) provide facilities for inspection during manufacture and use; and
- b) demonstrate compliance with these Instructions to the competent authority.

Where competent authority approval is required, such approval must take into account and be contingent upon the adequacy of the management system.

6.4 SPECIAL ARRANGEMENT

6.4.1 Special arrangement means those provisions, approved by the competent authority, under which consignments which do not satisfy all the requirements of these Instructions applicable to radioactive material may be transported.

6.4.2 Consignments for which conformity with any provision applicable to radioactive material is impracticable must not be transported except under special arrangement. Provided the competent authority is satisfied that conformity with the radioactive material provisions of these Instructions is impracticable and that the requisite standards of safety established by these Instructions have been demonstrated through alternative means, the competent authority may approve special arrangement transport operations for a single consignment or a planned series of multiple consignments. The overall level of safety in transport must be at least equivalent to that which would be provided if all the applicable requirements had been met. For international consignments of this type, multilateral approval must be required.

6.5 RADIOACTIVE MATERIAL POSSESSING OTHER DANGEROUS PROPERTIES

6.5.1 In addition to the radioactive and fissile properties, any subsidiary risk of the contents of a package, such as explosiveness, flammability, pyrophoricity, chemical toxicity and corrosiveness, must also be taken into account in the documentation, packing, labelling, marking, placarding, stowage, segregation and transport, in order to be in compliance with all relevant provisions for dangerous goods of these Instructions.

6.6 NON-COMPLIANCE

In the event of non-compliance with any limit in these Instructions applicable to radiation level or contamination:

- # a) the shipper, consignee, operator and any organization involved during transport, who may be affected, as appropriate, must be informed of the non-compliance:
 - i) by the operator if the non-compliance is identified during transport; or
 - ii) by the consignee if the non-compliance is identified at receipt;
- # b) the operator, shipper or consignee, as appropriate, must:
 - i) take immediate steps to mitigate the consequences of the non-compliance;
 - ii) investigate the non-compliance and its causes, circumstances and consequences;
 - iii) take appropriate action to remedy the causes and circumstances that led to the non-compliance and to prevent a recurrence of similar circumstances that led to the non-compliance; and
 - iv) communicate to the relevant competent authority(ies) the causes of the non-compliance and corrective or preventative actions taken or to be taken;
- # c) the communication of the non-compliance to the shipper and relevant competent authority(ies), respectively, must be made as soon as practicable and it must be immediate whenever an emergency exposure situation has developed or is developing.

Chapter 7

INCIDENT AND ACCIDENT REPORTING

Entities other than operators who are in possession of dangerous goods at the time a dangerous goods accident or incident occurs or at the time a dangerous goods incident is discovered to have occurred should follow the reporting requirements of Part 7;4.4. Entities other than operators who discover undeclared or misdeclared dangerous goods should follow the reporting requirements of Part 7;4.5. These entities may include, but are not limited to, freight forwarders, customs authorities and security screening providers.

Part 2

CLASSIFICATION OF DANGEROUS GOODS

INTRODUCTORY CHAPTER

Parts of this Chapter are affected by State Variations DE 5, NL 4; see Table A-1

1. RESPONSIBILITIES

Classification must be made by the appropriate national authority when so required or may otherwise be made by the shipper.

2. CLASSES, DIVISIONS, PACKING GROUPS — DEFINITIONS

2.1 Substances (including mixtures and solutions) and articles subject to these Instructions are assigned to one of nine classes according to the hazard or the most predominant of the hazards they present. Some of these classes are subdivided into divisions. These classes and divisions are:

Class 1: Explosives

- Division 1.1: Substances and articles which have a mass explosion hazard
- Division 1.2: Substances and articles which have a projection hazard but not a mass explosion hazard
- Division 1.3: Substances and articles which have a fire hazard and either a minor blast hazard or a minor projection hazard or both, but not a mass explosion hazard
- Division 1.4: Substances and articles which present no significant hazard
- Division 1.5: Very insensitive substances which have a mass explosion hazard
- Division 1.6: Extremely insensitive articles which do not have a mass explosion hazard

Class 2: Gases

- Division 2.1: Flammable gases
- Division 2.2: Non-flammable, non-toxic gases
- Division 2.3: Toxic gases

Class 3: Flammable liquids

Class 4: Flammable solids; substances liable to spontaneous combustion; substances which, on contact with water, emit flammable gases

- Division 4.1: Flammable solids, self-reactive and related substances and desensitized explosives
- Division 4.2: Substances liable to spontaneous combustion
- Division 4.3: Substances which, in contact with water, emit flammable gases

Class 5: Oxidizing substances and organic peroxides

- Division 5.1: Oxidizing substances
- Division 5.2: Organic peroxides

Class 6: Toxic and infectious substances

- Division 6.1: Toxic substances
- Division 6.2: Infectious substances

Class 7: Radioactive material

Class 8: Corrosive substances

Class 9: Miscellaneous dangerous substances and articles, including environmentally hazardous substances

The numerical order of the classes and divisions is not that of the degree of danger.

2.2 Many of the substances assigned to Classes 1 to 9 are deemed, without additional labelling, as being environmentally hazardous.

2.3 Wastes must be transported under the requirements of the appropriate class considering their hazards and the criteria in these Instructions. Wastes not otherwise subject to these Instructions, but covered under the Basel Convention, may be transported under Class 9.

2.4 For packing purposes, dangerous goods other than those of Classes 1, 2 and 7, Divisions 5.2 and 6.2 and self-reactive substances of Division 4.1 are assigned to three packing groups in accordance with the degree of danger they present:

- Packing Group I: Substances presenting high danger
- Packing Group II: Substances presenting medium danger
- Packing Group III: Substances presenting low danger

The packing group to which a substance is assigned is indicated in the Dangerous Goods List in Part 3, Chapter 2, Table 3-1.

- + Articles are not assigned to packing groups. For packing purposes, any requirement for a specific packaging performance level is set out in the applicable packing instruction.

2.5 Dangerous goods are determined to present one or more of the dangers represented by Classes 1 to 9 and divisions and, if applicable, the degree of danger on the basis of the requirements in Part 2, Chapters 1 to 9.

2.6 Dangerous goods presenting a danger of a single class and division are assigned to that class and division and the degree of danger (packing group), if applicable, determined. When an article or substance is specifically listed by name in the Dangerous Goods List (Table 3-1), its class or division, its subsidiary risk(s) and, when applicable, its packing group are taken from this list.

2.7 Where a substance or article is not specifically listed by name in Table 3-1 and there are two or more hazards of Class 3, 4 or 8 or Division 5.1 or 6.1 associated with its air transport in that it meets the definition for two of those classes or divisions as shown in Part 2, Chapters 1 to 9, it must be classified in accordance with the precedence of hazards table (Table 2-1).

3. UN NUMBERS AND PROPER SHIPPING NAMES

3.1 Dangerous goods are assigned to UN numbers and proper shipping names according to their hazard classification and their composition.

3.2 Dangerous goods commonly carried are listed in Table 3-1. Where an article or substance is specifically listed by name, it must be identified in transport by the proper shipping name in Table 3-1. Such substances may contain technical impurities (for example, those deriving from the production process) or additives for stability or other purposes that do not affect its classification. However, a substance listed by name containing technical impurities or additives for stability or other purposes affecting its classification must be considered a mixture or solution (see 3.5). For dangerous goods not specifically listed by name, "generic" or "not otherwise specified (n.o.s.)" entries are provided (see 3.8) to identify the article or substance in transport. Each entry in Table 3-1 is characterized by a UN number. Table 3-1 also contains relevant information for each entry, such as hazard class, subsidiary risk(s) (if any), packing group (where assigned), packing requirements, passenger and cargo aircraft requirements, etc. Entries in Table 3-1 are of the following four types:

- a) Single entries for well-defined substances or articles

e.g. Acetone	UN 1090
Ethyl nitrite solution	UN 1194

- b) Generic entries for a well-defined group of substances or articles

e.g. Adhesives	UN 1133
Perfumery products	UN 1266
Carbamate pesticide, solid, toxic	UN 2757

- c) Specific n.o.s. entries covering a group of substances or articles of a particular chemical or technical nature

e.g. Nitrates, inorganic, n.o.s.	UN 1477
Alcohols, n.o.s.	UN 1987

- d) General n.o.s. entries covering a group of substances or articles meeting the criteria of one or more classes or divisions

e.g. Flammable solid, organic, n.o.s.	UN 1325
Flammable liquid, n.o.s.	UN 1993

3.3 All self-reactive substances of Division 4.1 are assigned to one of twenty generic entries in accordance with the classification principles and flow chart described in the UN Recommendations, 2.4.2.3.3.

3.4 All organic peroxides of Division 5.2 are assigned to one of twenty generic entries in accordance with the classification principles and flow chart described in the UN Recommendations, 2.5.3.3.

3.5 A mixture or solution meeting the classification criteria of these Instructions and composed of a single predominant substance identified by name in Table 3-1 and one or more substances not subject to these Instructions and/or traces of one or more substances identified by name in Table 3-1 must be assigned the UN number and proper shipping name of the predominant substance named in Table 3-1, unless:

- a) the mixture or solution is identified by name in Table 3-1 in which case this name must be applied; or
- b) the name and description of the substance named in Table 3-1 specifically indicates that it applies only to the pure substance; or
- c) the hazard class or division, subsidiary risk(s), physical state or packing group of the solution or mixture is different from that of the substance named in Table 3-1; or
- d) the hazard characteristics and properties of the mixture or solution necessitate emergency response measures that are different from those required for the substance identified by name in Table 3-1.

If b), c) or d) is applicable, the mixture or solution must be treated as a dangerous substance not specifically listed by name in Table 3-1.

Note.— Although traces of substances may not need to be taken into account for classification purposes, those traces may affect the properties of the substance and do need to be taken into account when considering the compatibility requirements of 4.1.1.3.

3.6 For a solution or mixture when the hazard class, the physical state or the packing group is changed in comparison with the listed substance, the appropriate n.o.s. entry must be used including its packaging and labelling provisions.

3.7 A mixture or solution containing one or more substances identified by name in Table 3-1 or classified under an n.o.s. entry and one or more substances not subject to these Instructions is not subject to these Instructions if the hazard characteristics of the mixture or solution are such that they do not meet the criteria (including human experience criteria) for any class.

3.8 Substances or articles which are not specifically listed by name in Table 3-1 must be classified under a “generic” or “n.o.s.” entry. The substance or article must be classified according to the class definitions and test criteria in this Part, and is then assigned the “generic” or “n.o.s.” entry in Table 3-1 which most appropriately describes the article or substance.¹ This means that a substance is to be assigned to an entry of type c), as defined in 3.2, only if it cannot be assigned to an entry of type b), and to an entry of type d) only if it cannot be assigned to an entry of type b) or c)¹.

3.9 A mixture or solution meeting the classification criteria of these Instructions that is not identified by name in Table 3-1 and that is composed of two or more dangerous goods must be assigned to an entry that has the proper shipping name, description, hazard class or division, subsidiary risk(s) and packing group that most precisely describe the mixture or solution.

4. PRECEDENCE OF HAZARD CHARACTERISTICS

4.1 The precedence of hazards table (Table 2-1) must be used to determine the class of a substance, mixture or solution having more than one risk, when it is not named in Table 3-1. For goods having multiple risks, which are not specifically listed by name in Table 3-1, the most stringent packing group denoted to the respective hazards of the goods takes precedence over other packing groups, irrespective of Table 2-1. The correct class or division to be used is shown at the point at which the column and row intersect in Table 2-1. The correct packing group to be used is also shown at the point at which the column and row intersect. The precedence of hazard characteristics of the following have not been dealt with in Table 2-1, as the primary characteristics always take precedence:

- a) substances and articles of Class 1;
- b) gases of Class 2;
- c) liquid desensitized explosives of Class 3;
- d) self-reactive substances and solid desensitized explosives of Division 4.1;
- e) pyrophoric substances of Division 4.2;

1. See also the “List of n.o.s. and generic proper shipping names” in Attachment 1, Chapter 2.

- f) substances of Division 5.2;
- g) substances of Division 6.1 with a Packing Group I inhalation toxicity. Except for substances or preparations meeting the criteria of Class 8 having an inhalation toxicity of dusts and mists (LC₅₀) in the range of Packing Group I, but toxicity through oral ingestion or dermal contact only in the range of Packing Group III or less, which must be allocated to Class 8;
- h) substances of Division 6.2; and
- i) material of Class 7.

≠ 4.2 Apart from radioactive material in excepted packages (where the other hazardous properties take precedence), radioactive material having other hazardous properties must always be classified in Class 7 and the subsidiary risk must also be identified. For radioactive material in excepted packages, except for UN 3507, **Uranium hexafluoride, radioactive material, excepted package**, Special Provision A130 applies.

4.3 An article which, apart from its other hazards, also meets the criterion for a magnetized material, must be identified in accordance with the provisions of this section and in addition as a magnetized material.

5. TRANSPORT OF SAMPLES

5.1 When the hazard class of a substance is uncertain and it is being transported for further testing, a tentative hazard class, proper shipping name and identification number must be assigned on the basis of the shipper's knowledge of the substance and application of:

- a) the classification criteria of these Instructions; and
- b) the precedence of hazards given above.

The most severe packing group possible for the shipping name chosen must be used.

5.2 Where this provision is used, the proper shipping name must be supplemented with the word "sample" (e.g. **Flammable liquid, n.o.s., sample**). In certain instances, where a specific proper shipping name is provided for a sample of a substance considered to meet certain classification criteria (e.g. **Gas sample, non-pressurized, flammable**, UN 3167), that proper shipping name must be used. When an n.o.s. entry is used to transport the sample, the proper shipping name need not be supplemented with the technical name.

5.3 Samples of the substance must be transported in accordance with the requirements applicable to the tentative assigned proper shipping name provided:

- a) the substance is not considered to be a substance forbidden for transport by 1;2.1;
- b) the substance is not considered to meet the criteria for Class 1 or considered to be an infectious substance or a radioactive material;
- c) the substance is in compliance with 4.2.3.2.6 or 5.3.2.6, if it is a self-reactive substance or an organic peroxide, respectively;
- d) the sample is transported in a combination packaging with a net mass per package not exceeding 2.5 kg; and
- e) the sample is not packed together with other goods.

Table 2-1. Precedence of hazards and packing groups for Classes 3, 4 and 8 and for Divisions 5.1 and 6.1

Class or division and packing group	Class or division and packing group																	
	4.2 II	4.2 III	4.3 I	4.3 II	4.3 III	5.1 I	5.1 II	5.1 III	6.1 I (d)	6.1 I (o)	6.1 II	6.1 III	8 I (l)	8 I (s)	8 II (l)	8 II (s)	8 III (l)	8 III (s)
3 I*			4.3,I	4.3,I	4.3,I	—	—	—	3,I	3,I	3,I	3,I	3,I	—	3,I	—	3,I	—
3 II*			4.3,I	4.3,II	4.3,II	—	—	—	3,I	3,I	3,II	3,II	8,I	—	3,II	—	3,II	—
3 III*			4.3,I	4.3,II	4.3,III	—	—	—	6.1,I	6.1,I	6.1,II	3,III**	8,I	—	8,II	—	3,III	—
4.1 II*	4.2,II	4.2,II	4.3,I	4.3,II	4.3,II	5.1,I	4.1,II	4.1,II	6.1,I	6.1,I	4.1,II	4.1,II	—	8,I	—	4.1,II	—	4.1,II
4.1 III*	4.2,II	4.2,III	4.3,I	4.3,II	4.3,III	5.1,I	4.1,II	4.1,III	6.1,I	6.1,I	6.1,II	4.1,III	—	8,I	—	8,II	—	4.1,III
4.2 II			4.3,I	4.3,II	4.3,II	5.1,I	4.2,II	4.2,II	6.1,I	6.1,I	4.2,II	4.2,II	8,I	8,I	4.2,II	4.2,II	4.2,II	4.2,II
4.2 III			4.3,I	4.3,II	4.3,III	5.1,I	5.1,II	4.2,III	6.1,I	6.1,I	6.1,II	4.2,III	8,I	8,I	8,II	8,II	4.2,III	4.2,III
4.3 I						5.1,I	4.3,I	4.3,I	6.1,I	4.3,I	4.3,I	4.3,I	4.3,I	4.3,I	4.3,I	4.3,I	4.3,I	4.3,I
4.3 II						5.1,I	4.3,II	4.3,II	6.1,I	4.3,I	4.3,II	4.3,II	8,I	8,I	4.3,II	4.3,II	4.3,II	4.3,II
4.3 III						5.1,I	5.1,II	4.3,III	6.1,I	6.1,I	6.1,II	4.3,III	8,I	8,I	8,II	8,II	4.3,III	4.3,III
5.1 I									5.1,I	5.1,I	5.1,I	5.1,I	5.1,I	5.1,I	5.1,I	5.1,I	5.1,I	5.1,I
5.1 II									6.1,I	5.1,I	5.1,II	5.1,II	8,I	8,I	5.1,II	5.1,II	5.1,II	5.1,II
5.1 III									6.1,I	6.1,I	6.1,II	5.1,III	8,I	8,I	8,II	8,II	5.1,III	5.1,III
6.1 I (d)													8,I	6.1,I	6.1,I	6.1,I	6.1,I	6.1,I
6.1 I (o)													8,I	6.1,I	6.1,I	6.1,I	6.1,I	6.1,I
6.1 II (i)													8,I	6.1,I	6.1,II	6.1,II	6.1,II	6.1,II
6.1 II (d)													8,I	6.1,I	8,II	6.1,II	6.1,II	6.1,II
6.1 II (o)													8,I	8,I	8,II	6.1,II	6.1,II	6.1,II
6.1 III													8,I	8,I	8,II	8,II	8,III	8,III

(l) = liquid; (s) = solid; (i) = inhalation; (d) = dermal; (o) = oral; — = an impossible combination

* Substances of Division 4.1 other than self-reactive substances, and solid desensitized explosives and substances of Class 3 other than liquid desensitized explosives.

** For pesticides only, the primary risk must be Division 6.1.

Chapter 1

CLASS 1 — EXPLOSIVES

Parts of this Chapter are affected by State Variations BE 2, DK 2, DQ 2, GB 1, HK 3, HR 5, KG 2, PE 1, US 5; see Table A-1

Note 1.— Class 1 is a restricted class, that is, only those explosive substances and articles that are listed in the Dangerous Goods List may be accepted for transport. However, the appropriate authorities of the States concerned retain the right by mutual agreement to approve transport of explosive substances and articles for special purposes under special conditions. Therefore, entries have been included in the Dangerous Goods List for “Substances, explosive, n.o.s.” and “Articles, explosive, n.o.s.”. It is intended that these entries be used only when no other method of operation is possible.

Note 2.— General entries, such as “Explosive, blasting, Type A”, are used to allow for the transport of new substances. In preparing these requirements, military ammunition and explosives have been taken into consideration to the extent that they are likely to be transported by civil aircraft.

Note 3.— A number of substances and articles which are in Class 1 are described in Attachment 2 to these Instructions. These descriptions are given because a term may not be well known or may be at variance with its usage for regulatory purposes.

Note 4.— Class 1 is unique in that the type of packaging frequently has a decisive effect on the hazard and therefore on the assignment to a particular division. The correct division is determined by use of the procedures provided in this Chapter.

Note 5.— Most of the explosives listed in Table 3-1 are not normally permitted for transport by air. Information concerning these explosives is included in Table 3-1 and in the Supplement to these Instructions to provide guidance for States in those cases where consideration is being given to granting exemptions in accordance with 1;1.1.2.

1.1 DEFINITIONS AND GENERAL PROVISIONS

Class 1 comprises:

- a) explosive substances (a substance that is not itself an explosive but which can form an explosive atmosphere of gas, vapour or dust is not included in Class 1), except those that are too dangerous to transport or those where the predominant hazard is appropriate to another class;
- b) explosive articles, except devices containing explosive substances in such quantity or of such a character that their inadvertent or accidental ignition or initiation during transport will not cause any effect external to the device either by projection, fire, smoke, heat or loud noise (see 1.5.2); and
- c) substances and articles not mentioned under 1.1 a) and b), which are manufactured with a view to producing a practical, explosive or pyrotechnic effect.

1.2 DEFINITIONS

For the purposes of these Instructions, the following definitions apply:

- a) **Explosive substance** is a solid or liquid substance (or a mixture of substances) which is in itself capable, by chemical reaction, of producing gas at such a temperature and pressure and at such a speed as to cause damage to the surroundings. Pyrotechnic substances are included even when they do not evolve gases.
- b) **Pyrotechnic substance** is a substance or a mixture of substances designed to produce an effect by heat, light, sound, gas or smoke or a combination of these as the result of non-detonative, self-sustaining, exothermic, chemical reactions.
- c) **Explosive article** is an article containing one or more explosive substances.
- d) **Phlegmatized** means that a substance (or “phlegmatizer”) has been added to an explosive to enhance its safety in handling and transport. The phlegmatizer renders the explosive insensitive, or less sensitive, to the following actions: heat, shock, impact, percussion or friction. Typical phlegmatizing agents include, but are not limited to: paper, wax, water, polymers (such as chlorofluoropolymers), alcohol and oils (such as petroleum jelly and paraffin).

Note.— Explanations for a number of other terms used in connection with explosives can be found in Attachment 2 to these Instructions.

1.3 DIVISIONS

1.3.1 Class 1 is divided into six divisions:

- a) Division 1.1 — Substances and articles which have a mass explosion hazard (a mass explosion is one which affects almost the entire load virtually instantaneously).
- b) Division 1.2 — Substances and articles which have a projection hazard but not a mass explosion hazard.
- c) Division 1.3 — Substances and articles which have a fire hazard and either a minor blast hazard or a minor projection hazard or both, but not a mass explosion hazard.

This division comprises substances and articles which:

- i) give rise to considerable radiant heat, or
 - ii) burn one after another, producing minor blast or projection effects or both.
- d) Division 1.4 — Substances and articles which present no significant hazard.

This division comprises substances and articles which present only a small hazard in the event of ignition or initiation during transport. The effects are largely confined to the package and no projection of fragments of appreciable size or range is to be expected. An external fire must not cause virtually instantaneous explosion of almost the entire contents of the package.

Note.— Substances and articles of this division are in Compatibility Group S if they are so packaged or designed that any hazardous effects arising from accidental functioning are confined within the package, unless the package has been degraded by fire, in which case all blast or projection effects are limited to the extent that they do not significantly hinder fire fighting or other emergency response efforts in the immediate vicinity of the package.

- e) Division 1.5 — Very insensitive substances which have a mass explosion hazard.

This division comprises substances which have a mass explosion hazard but are so insensitive that there is very little probability of initiation or of transition from burning to detonation under normal conditions of transport.

Note.— For the normal conditions of transport, see Notes 2 to 4 of the Introductory Notes to Part 4.

- f) Division 1.6 — Extremely insensitive articles which do not have a mass explosion hazard.

This division comprises articles which contain only extremely insensitive substances and which demonstrate a negligible probability of accidental initiation or propagation.

Note.— The risk from articles of Division 1.6 is limited to the explosion of a single article.

1.3.2 Any substance or article having or suspected of having explosive characteristics must first be considered for classification in Class 1 in accordance with the procedures in 1.5.1.1 to 1.5.1.3. Goods are not classified in Class 1 when:

- a) unless specially authorized, the transport of an explosive substance is forbidden because sensitivity of the substance is excessive;
- b) the substance or article comes within the scope of those explosive substances and articles which are specifically excluded from Class 1 by the definition of this class; or
- c) the substance or article has no explosive properties.

1.4 COMPATIBILITY GROUPS

1.4.1 Goods of Class 1 are assigned to one of six divisions, depending on the type of hazard they present (see 1.3.1), and to one of thirteen compatibility groups which identify the kinds of explosive substances and articles that are deemed to be compatible. Tables 2-2 and 2-3 show the scheme of classification into compatibility groups, the possible hazard divisions associated with each group, and the consequential classification codes.

1.4.2 The definitions of compatibility groups in Table 2-2 are intended to be mutually exclusive, except for a substance or article which qualifies for Compatibility Group S. Since the criterion of Compatibility Group S is an empirical one, assignment to this group is necessarily linked to the tests for assignment to Division 1.4.

1.4.2.1 Certain Division 1.4S explosives, identified by Special Provision A165 in Table 3-1, are subject to Test Series 6 (d) of Part I of the *UN Manual of Tests and Criteria* (see ST/SG/AC.10/36/Add.2) to demonstrate that any hazardous effects arising from functioning are confined within the package. Evidence of a hazardous effect outside the package includes:

- a) denting or perforation of the witness plate beneath the package;
- b) a flash or flame capable of igniting such as a sheet of 80 ± 3 g/m² paper at a distance of 25 cm from the package;
- c) disruption of the package causing projection of the explosives contents; or
- d) a projection which passes completely through the packaging (a projection or fragment retained or stuck in the wall of the packaging is considered as non-hazardous).

The appropriate national authority may wish to take into account the expected effect of the initiator when assessing the results of the test, if these are expected to be significant when compared to the articles being tested. If there are hazardous effects outside the package, then the product is excluded from Compatibility Group S.

1.5 CLASSIFICATION OF EXPLOSIVES

Note.— For additional information regarding classification of explosives, see UN Recommendations, 2.1.3.1.4, 2.1.3.1.5 and 2.1.3.4.

Table 2-2. Classification codes

<i>Description of substance or article to be classified</i>	<i>Compatibility group</i>	<i>Classification code</i>
Primary explosive substance	A	1.1A
Article containing a primary explosive substance and not containing two or more effective protective features. Some articles, such as detonators for blasting, detonator assemblies for blasting and primers, and cap-type, are included even though they do not contain primary explosives	B	1.1B 1.2B 1.4B
Propellant explosive substance or other deflagrating explosive substance or article containing such explosive substance	C	1.1C 1.2C 1.3C 1.4C
Secondary detonating explosive substance or black powder or article containing a secondary detonating explosive substance, in each case without means of initiation and without a propelling charge, or article containing a primary explosive substance and containing two or more effective protective features	D	1.1D 1.2D 1.4D 1.5D
Article containing a secondary detonating explosive substance, without means of initiation, with a propelling charge (other than one containing a flammable liquid or gel or hypergolic liquids)	E	1.1E 1.2E 1.4E
Article containing a secondary detonating explosive substance with its own means of initiation, with a propelling charge (other than one containing a flammable liquid or gel or hypergolic liquids) or without a propelling charge	F	1.1F 1.2F 1.3F 1.4F
Pyrotechnic substance, or article containing a pyrotechnic substance, or article containing both an explosive substance and an illuminating, incendiary, tear- or smoke-producing substance (other than a water-activated article or one containing white phosphorus, phosphides, a pyrophoric substance, a flammable liquid or gel, or hypergolic liquids)	G	1.1G 1.2G 1.3G 1.4G
Article containing both an explosive substance and white phosphorus	H	1.2H 1.3H
Article containing both an explosive substance and a flammable liquid or gel	J	1.1J 1.2J 1.3J

<i>Description of substance or article to be classified</i>	<i>Compatibility group</i>	<i>Classification code</i>
Article containing both an explosive substance and a toxic chemical agent	K	1.2K 1.3K
Explosive substance or article containing an explosive substance and presenting a special risk (e.g. due to water activation or presence of hypergolic liquids, phosphides or a pyrophoric substance) and needing isolation of each type	L	1.1L 1.2L 1.3L
Articles containing only extremely insensitive substances	N	1.6N
Substances or articles so packed or designed that any hazardous effects arising from accidental functioning are confined within the package unless the package has been degraded by fire, in which case all blast or projection effects are limited to the extent that they do not significantly hinder or prohibit fire fighting or other emergency response in the immediate vicinity of the package	S	1.4S

Note 1.— Articles of Compatibility Groups D and E may be fitted or packed together with their own means of initiation provided that such means have at least two effective protective features designed to prevent an explosion in the event of accidental functioning of the means of initiation. Such articles and packages must be assigned to Compatibility Groups D or E.

Note 2.— Articles of Compatibility Groups D and E may be packed together with their own means of initiation, which do not have two effective protective features when, in the opinion of the appropriate national authority of the State of Origin, the accidental functioning of the means of initiation does not cause the explosion of an article under normal conditions of transport. Such packages must be assigned to Compatibility Groups D or E.

Table 2-3. Scheme of classification of explosives, combination of hazard division with compatibility group

Hazard	Compatibility Group													A-S
	A	B	C	D	E	F	G	H	J	K	L	N	S	Σ
1.1	1.1A	1.1B	1.1C	1.1D	1.1E	1.1F	1.1G		1.1J		1.1L			9
1.2		1.2B	1.2C	1.2D	1.2E	1.2F	1.2G	1.2H	1.2J	1.2K	1.2L			10
1.3			1.3C			1.3F	1.3G	1.3H	1.3J	1.3K	1.3L			7
1.4		1.4B	1.4C	1.4D	1.4E	1.4F	1.4G						1.4S	7
1.5				1.5D										1
1.6												1.6N		1
1.1-1.6 Σ		3	4	4	3	4	4	2	3	2	3	1	1	35

1.5.1.1 Any substance or article having or suspected of having explosive characteristics must be considered for classification in Class 1 in accordance with the tests, procedures and criteria prescribed in Part I of the *UN Manual of Tests and Criteria*. Substances and articles classified in Class 1 must be assigned to the appropriate division and compatibility group in accordance with the procedures and criteria prescribed in that document.

1.5.1.2 The classification of fireworks must be based on paragraph 2.1.3.5 of the UN Recommendations.

1.5.1.3 Except for substances that are listed by their proper shipping name in the Dangerous Goods List (Table 3-1), goods must not be offered for transport as Class 1 until they have been subjected to the classification procedure prescribed in this Chapter. In addition, the classification procedure must be undertaken before a new product is offered for transport. In this context, a new product is one which, in the opinion of the appropriate national authority, involves any of the following:

- a) a new explosive substance or a combination or a mixture of explosive substances which is considered to be significantly different from other combinations or mixtures already classified;
- b) a new design of article or an article containing a new explosive substance or a new combination or mixture of explosive substances;
- c) a new design of package for an explosive substance or article including a new type of inner packaging.

Note.— The importance of this can be overlooked unless it is realized that a relatively minor change in an inner or outer packaging can be critical and can convert a lesser risk into a mass explosion risk.

1.5.1.4 The producer or other applicant for classification of the product must provide adequate information concerning the names and characteristics of all explosive substances in the product and must furnish the results of all relevant tests which have been done. It is assumed that all the explosive substances in a new article have been properly tested and then approved.

1.5.2 Exclusion from Class 1

1.5.2.1 The appropriate national authority may exclude an article or substance from Class 1 by virtue of test results and the Class 1 definition.

1.5.2.2 Where a substance provisionally accepted into Class 1 is excluded from Class 1 by performing Test Series 6 on a specific type and size of package, this substance, when meeting the classification criteria or definition for another class or division, should be listed in the Dangerous Goods List in that class or division with a special provision restricting it to the type and size of package tested.

1.5.2.3 Where a substance is assigned to Class 1 but is diluted to be excluded from Class 1 by Test Series 6, this diluted substance (hereafter referred to as desensitized explosive) should be listed in the Dangerous Goods List with an indication of the highest concentration which excluded it from Class 1 (see 2;3.1.4 and 2;4.2.4) and if applicable, the concentration below which it is no longer deemed subject to these Instructions. New solid desensitized explosives subject to these Instructions should be listed in Division 4.1, and new liquid desensitized explosives should be listed in Class 3. When the desensitized explosive meets the criteria or definition for another class or division, the corresponding subsidiary risk(s) should be assigned to it.

1.5.2.4 An article may be excluded from Class 1 when three unpackaged articles, each individually activated by its own means of initiation or ignition or external means to function in the designed mode, meet the following test criteria:

- a) no external surface has a temperature of more than 65°C. A momentary spike in temperature up to 200°C is acceptable;
- b) no rupture or fragmentation of the external casing or movement of the article or detached parts thereof of more than one metre in any direction;

Note.— Where the integrity of the article may be affected in the event of an external fire, these criteria must be examined by a fire test, such as described in ISO 12097-3.

- c) no audible report exceeding 135 dB(C) peak at a distance of one metre;
- d) no flash or flame capable of igniting a material such as a sheet of 80 ± 10 g/m² paper in contact with the article; and
- e) no production of smoke, fumes or dust in such quantities that the visibility in a one cubic metre chamber equipped with appropriately sized blow out panels is reduced more than 50 per cent as measured by a calibrated light (lux) meter or radiometer located one metre from a constant light source located at the midpoint on opposite walls. The general guidance on optical density testing in ISO 5659-1 and the general guidance on the photometric system described in Section 7.5 in ISO 5659-2 may be used or similar optical density measurement methods designed to accomplish the same purpose may also be employed. A suitable hood cover surrounding the back and sides of the light meter must be used to minimize effects of scattered or leaking light not emitted directly from the source.

Note 1.— If during the tests addressing criteria a), b), c) and d), no smoke, or very little smoke is observed, the test described in e) may be waived.

Note 2.— The appropriate national authority may require testing in packaged form if it is determined that, as packaged for transport, the article may pose a greater risk.

Chapter 2

CLASS 2 — GASES

*Parts of this Chapter are affected by State Variation US 6;
see Table A-1*

2.1 DEFINITIONS AND GENERAL PROVISIONS

2.1.1 A gas is a substance which:

- a) at 50°C has a vapour pressure greater than 300 kPa; or
- b) is completely gaseous at 20°C at a standard pressure of 101.3 kPa.

2.1.2 The transport condition of a gas is described according to its physical state as:

- a) compressed gas — a gas which when packaged under pressure for transport is entirely gaseous at –50°C; this category includes all gases with a critical temperature less than or equal to –50°C;
- b) liquefied gas — a gas which when packaged under pressure for transport is partially liquid at temperatures above –50°C. A distinction is made between:

High pressure liquefied gas: a gas with a critical temperature between –50°C and +65°C, and

Low pressure liquefied gas: a gas with a critical temperature above +65°C;

- ≠ c) refrigerated liquefied gas — a gas which when packaged for transport is made partially liquid because of its low temperature;
- ≠ d) dissolved gas — a gas which when packaged under pressure for transport is dissolved in a liquid phase solvent; or
- + e) adsorbed gas — a gas which when packaged for transport is adsorbed onto a solid porous material resulting in an internal receptacle pressure of less than 101.3 kPa at 20°C and less than 300 kPa at 50°C.

2.1.3 This class comprises compressed gases; liquefied gases; dissolved gases; refrigerated liquefied gases; mixtures of one or more gases with one or more vapours of substances of other classes; articles charged with a gas; and aerosols. (For aerosols, see 1;3.1.)

Note.—“Cryogenic liquid” means the same as “refrigerated liquefied gas”.

2.1.4 Pressures of all kinds relating to receptacles (such as test pressure, internal pressure, safety-valve opening pressure) are always indicated in gauge pressure (pressure in excess of atmospheric pressure); however, the vapour pressure of substances is always expressed in absolute pressure.

2.2 DIVISIONS

2.2.1 Substances of Class 2 are assigned to one of three divisions based on the primary hazard of the gas during transport.

*Note.— UN 1950 — **Aerosols**, UN 2037 — **Receptacles, small, containing gas** and UN 2037 — **Gas cartridges** must be regarded as being in Division 2.1 when the criteria in 2.5.1 a) are met.*

- a) Division 2.1 — Flammable gases.

Gases which at 20°C and a standard pressure of 101.3 kPa:

- i) are ignitable when in a mixture of 13 per cent or less by volume with air; or

- ii) have a flammable range with air of at least 12 percentage points regardless of the lower flammable limit. Flammability must be determined by tests or by calculation in accordance with methods adopted by ISO (see ISO 10156:2010). Where insufficient data are available to use these methods, tests by a comparable method recognized by the appropriate national authority must be used.

Note.— UN 1950 — Aerosols and UN 2037 — Receptacles, small, containing gas must be regarded as being in Division 2.1 when the criteria in 2.5.1 a) are met.

- b) Division 2.2 — Non-flammable, non-toxic gases.

Gases which:

- i) are asphyxiant — gases which dilute or replace the oxygen normally in the atmosphere; or
- ii) are oxidizing — gases which may, generally by providing oxygen, cause or contribute to the combustion of other material more than air does; or
- iii) do not come under the other divisions.

Note.— In 2.2.1 b) ii), “gases which cause or contribute to the combustion of other material more than air does” means pure gases or gas mixtures with an oxidizing power greater than 23.5 per cent as determined by a method specified in ISO 10156:2010.

- c) Division 2.3 — Toxic gases.

Gases which:

- i) are known to be so toxic or corrosive to humans as to pose a hazard to health; or
- ii) are presumed to be toxic or corrosive to humans because they have an LC₅₀ value equal to or less than 5 000 mL/m³ (ppm) when tested in accordance with 6.2.1.3.

Note.— Gases meeting the above criteria owing to their corrosivity are to be classified as toxic with a subsidiary corrosive risk.

2.2.2 Gases of Division 2.2 are not subject to these Instructions if they are transported at a pressure less than 200 kPa at 20°C and are not liquefied or refrigerated liquefied gases.

2.2.3 Gases of Division 2.2 are not subject to these Instructions when contained in the following:

- a) foodstuffs, including carbonated beverages (except UN 1950);

≠ b) balls intended for use in sports; or

≠ c) tyres which meet the provisions of Special Provision A59.

>

+ *Note.— This exemption does not apply to lamps. For lamps see 1;2.6.*

2.3 HAZARD PRECEDENCE

Gases and gas mixtures with hazards associated with more than one division take the following precedence:

- a) Division 2.3 takes precedence over all other divisions;
- b) Division 2.1 takes precedence over Division 2.2.

2.4 MIXTURES OF GASES

For the classification of gas mixtures into one of the three divisions (including vapours of substance from other classes), the following principles must be used:

- a) Flammability must be determined by tests or by calculation in accordance with methods adopted by ISO (see ISO 10156:2010). Where insufficient data are available to use these methods, tests by a comparable method recognized by the appropriate national authority may be used.

- b) The level of toxicity is determined by either tests in accordance with 6.2.1.3 or a calculation method using the following formula:

$$LC_{50} \text{Toxic (mixture)} = \frac{1}{\sum_{i=1}^n \frac{f_i}{T_i}}$$

where f_i = mole fraction of the i^{th} component substance of the mixture, and

where T_i = toxicity index of the i^{th} component substance of the mixture (the T_i equals the LC_{50} value when available).

When LC_{50} values are unknown, the toxicity index is determined by using the lowest LC_{50} value of substances of similar physiological and chemical effects, or through testing if this is the only practical possibility.

- c) A gas mixture has a subsidiary risk of corrosivity when the mixture is known by human experience to be destructive to the skin, eyes or mucous membranes or when the LC_{50} value of the mixture's corrosive components is equal to or less than 5 000 mL/m³ (ppm) when the LC_{50} value is calculated by the formula:

$$LC_{50} \text{Corrosive (mixture)} = \frac{1}{\sum_{i=1}^n \frac{f_{ci}}{T_{ci}}}$$

where f_{ci} = mole fraction of the i^{th} corrosive component substance of the mixture, and

where T_{ci} = Toxicity index of the i^{th} corrosive component substance of the mixture (the T_{ci} equals the LC_{50} value when available).

- d) Oxidizing ability is determined either by tests or by calculation methods adopted by the International Standards Organization (see the Note in 2.2.1 b) and ISO 10156:2010).

2.5 AEROSOLS

2.5.1 For aerosols, the division of Class 2 and the subsidiary risks depend on the nature of the contents of the aerosol dispenser. The following provisions must apply:

- Division 2.1 applies if the contents include 85 per cent by mass or more flammable components and the chemical heat of combustion is 30 kJ/g or more;
- Division 2.2 applies if the content contains 1 per cent by mass or less flammable components and the heat of combustion is less than 20 kJ/g;
- otherwise the product must be classified as tested by the tests described in the UN *Manual of Tests and Criteria*, Part III, section 31. Extremely flammable and flammable aerosols must be classified in Division 2.1; non-flammable in Division 2.2;
- gases of Division 2.3 must not be used as a propellant in an aerosol dispenser;
- where the contents other than the propellant of aerosol dispensers to be ejected are classified as Division 6.1, Packing Groups II or III or Class 8, Packing Groups II or III, the aerosol must have a subsidiary risk of Division 6.1 or Class 8;
- aerosols with contents meeting the criteria of Packing Group I for toxicity or corrosivity are forbidden from transport.

2.5.2 Flammable components are flammable liquids, flammable solids or flammable gases and gas mixtures as defined in Notes 1 to 3 of subsections 31.1.3 of Part III of the UN *Manual of Tests and Criteria*. This designation does not cover pyrophoric, self-heating or water-reactive substances. The chemical heat of combustion must be determined by one of the following methods: ASTM D 240, ISO/FDIS 13943: 1999 (E/F) 86.1 to 86.3 or NFPA 30B.

Chapter 3

CLASS 3 — FLAMMABLE LIQUIDS

INTRODUCTORY NOTES

Note 1.— The word “flammable” has the same meaning as “inflammable”.

Note 2.— The flash point of a flammable liquid may be altered by the presence of an impurity. The substances listed in Class 3 in the Dangerous Goods List in Part 3 must generally be regarded as chemically pure. Since commercial products may contain added substances or impurities, flash points may vary, and this may have an effect on classification or determination of the packing group for the product. In the event of doubt regarding the classification or packing group of a substance, the flash point of the substance must be determined experimentally.

3.1 DEFINITION AND GENERAL PROVISIONS

3.1.1 Class 3 includes the following substances:

- a) Flammable liquids (see 3.1.2 and 3.1.3);
- b) Liquid desensitized explosives (see 3.1.4).

3.1.2 Flammable liquids are liquids, or mixtures of liquids, or liquids containing solids in solution or suspension (for example paints, varnishes, lacquers, etc., but not including substances otherwise classified on account of their dangerous characteristics) which give off a flammable vapour at temperatures of not more than 60°C, closed-cup test, or not more than 65.6°C, open-cup test, normally referred to as the flash point. This class also includes:

- a) liquids offered for transport at temperatures at or above their flash point; and
- b) substances that are transported or offered for transport at elevated temperatures in a liquid state and which give off a flammable vapour at a temperature at or below the maximum transport temperature (i.e. the maximum temperature likely to be encountered by the substance in transport).

Note. — Since the results of open-cup tests and of closed-cup tests are not strictly comparable and even individual results by the same test are often variable, regulations varying from the above figures to make allowance for such differences would be within the spirit of this definition.

3.1.3 Liquids meeting the definition in 3.1.2 above with a flash point of more than 35°C which do not sustain combustion need not be considered as flammable liquids for the purposes of these Instructions. Liquids are considered to be unable to sustain combustion for the purposes of these Instructions (i.e. they do not sustain combustion under defined test conditions) if:

- a) they have passed a suitable combustibility test (see Sustained Combustibility Test prescribed in the UN *Manual of Tests and Criteria*, Part III, subsection 32.5.2); or
- b) their fire point according to ISO 2592:2000 is greater than 100°C; or
- c) they are miscible solutions with a water content of more than 90 per cent by mass.

3.1.4 Liquid desensitized explosives are explosive substances which are dissolved or suspended in water or other liquid substances, to form homogeneous liquid mixture to suppress their explosive properties (see 1.5.2.3). Entries in the Dangerous Goods List (Table 3-1) for liquid desensitized explosives are: UN 1204, UN 2059, UN 3064, UN 3343, UN 3357 and UN 3379.

3.2 ASSIGNMENT OF PACKING GROUPS

3.2.1 Table 2-4 should be used for the determination of the packing group of a liquid that presents a risk due to flammability. For liquids whose only hazard is flammability, the packing group for the material is the packing group shown in Table 2-4. For a liquid possessing an additional hazard(s), the packing group, determined by using Table 2-4, and the packing group based on the severity of the additional hazard(s), must be considered. In such cases, the table of precedence of hazard characteristics appearing in Table 2-1 should be used to determine the correct classification of the liquid.

≠ 3.2.2 Viscous flammable liquids such as paints, enamels, lacquers, varnishes, adhesives and polishes having a flash point of less than 23°C may be assigned to Packing Group III in conformity with the procedures prescribed in Part III, subsection 32.3 of the UN *Manual of Tests and Criteria* provided that:

- ≠ a) the viscosity expressed as the flowtime in seconds and flash point are in accordance with Table 2-5;
- ≠ b) less than 3 per cent of the clear solvent layer separates in the solvent separation test;
- ≠ c) the mixture or any separated solvent does not meet the criteria for Division 6.1 or Class 8;
- ≠ d) the net quantity per package does not exceed 30 L for passenger aircraft or 100 L for cargo aircraft.

3.2.3 Substances classified as flammable liquids due to their being transported or offered for transport at elevated temperatures are included in Packing Group III.

3.3 DETERMINATION OF FLASH POINT

The following methods for determining the flash point of flammable liquids may be used:

International standards

- ISO 1516
- ISO 1523
- ISO 2719
- ISO 13736
- ISO 3679
- ISO 3680

National standards

American Society for Testing Materials International, 100 Barr Harbor Drive, PO Box C700, West Conshohocken, Pennsylvania, USA 19428-2959

- ASTM D-3828-93, Standard Test Methods for Flash Point by Small Scale Closed Tester
- ASTM D-56-93, Standard Test Method for Flash Point by Tag Closed Tester
- ASTM D-3278-96, Standard Test Methods for Flash Point of Liquids by Setaflash Closed-Cup Apparatus
- ASTM D-0093-96, Standard Test Methods for Flash Point by Pensky-Martens Closed-Cup Tester.

Association française de normalisation, AFNOR, 11, rue Francis de Pressensé, 93571 La Plaine Saint-Denis Cedex, France

- French Standard NF M 07-019
- French Standards NF M 07-011 / NF T 30-050 / NF T 66-009
- French Standard NF M 07-036

Deutsches Institut für Normung, Burggrafenstrasse 6, D-10787 Berlin

- Standard DIN 51755 (flash points below 65°C)

State Committee of the Council of Ministers for Standardization, 113813, GSP, Moscow, M-49 Leninsky Prospect, 9

- GOST 12.1.044-84

3.4 DETERMINATION INITIAL BOILING POINT

The following methods for determining the initial boiling point of flammable liquids may be used:

International standards

- ISO 3924
- ISO 4626
- ISO 3405

National standards

American Society for Testing Materials International, 100 Barr Harbor Drive, PO Box C700, West Conshohocken, Pennsylvania, USA 19428-2959

- ASTM D-86-07a, Standard Test Method for Distillation of Petroleum Products at Atmospheric Pressure
- ASTM D-1078-05, Standard Test Method for Distillation Range of Volatile Organic Liquids

Further acceptable methods

- Method A.2 as described in Part A of the Annex to Commission Regulation (EC) No 440/2008²

Table 2-4. Packing group based on flammability

<i>Packing group</i>	<i>Flash point (closed-cup)</i>	<i>Initial boiling point</i>
I	—	≤35°C
II	<23°C	>35°C
III	≥23°C, ≤60°C	>35°C

Table 2-5. Viscosity and flashpoints

<i>Flow time t in seconds</i>	<i>Jet diameter in mm</i>	<i>Flash point in °C (closed-cup)</i>
20 < t ≤ 60	4	above 17
60 < t ≤ 100	4	above 10
20 < t ≤ 32	6	above 5
32 < t ≤ 44	6	above -1
44 < t ≤ 100	6	above -5
100 < t	6	-5 and below

2. Commission Regulation (EC) No 440/2008 of 30 May 2008 laying down test methods pursuant to Regulation (EC) No 1907/2006 of the European Parliament and of the Council on the Registration, Evaluation, Authorisation and Restriction of Chemicals (REACH) (Official Journal of the European Union, No. L 142 of 31.05.2008, p.1-739 and No. L 143 of 03.06.2008, p.55).

Chapter 4

CLASS 4 — FLAMMABLE SOLIDS; SUBSTANCES LIABLE TO SPONTANEOUS COMBUSTION; SUBSTANCES WHICH, IN CONTACT WITH WATER, EMIT FLAMMABLE GASES

INTRODUCTORY NOTES

Note 1.— Where the term “water-reactive” is used in these Instructions, it refers to a substance which, in contact with water, emits flammable gas.

Note 2.— Because of the different properties exhibited by the dangerous goods within Divisions 4.1 and 4.2, it is impracticable to establish a single criterion for classification in either of these divisions. Tests and criteria for assignment to the three divisions of Class 4 are addressed in this chapter and in the UN Manual of Tests and Criteria, Part III, section 33.

Note 3.— Since organometallic substances can be classified in Divisions 4.2 or 4.3 with additional subsidiary risks, depending on their properties, a specific classification flowchart for these substances is given in 2.4.5 of the UN Recommendations on the Transport of Dangerous Goods.

4.1 DEFINITIONS AND GENERAL PROVISIONS

4.1.1 Class 4 is divided into three divisions as follows:

a) Division 4.1 — Flammable solids.

Solids which, under conditions encountered in transport, are readily combustible or may cause or contribute to fire through friction; self-reactive substances which are liable to undergo a strongly exothermic reaction; desensitized explosives which may explode if not diluted sufficiently.

b) Division 4.2 — Substances liable to spontaneous combustion.

Substances which are liable to spontaneous heating under normal conditions encountered in transport, or to heating up in contact with air, and being then liable to catch fire.

c) Division 4.3 — Substances which, in contact with water, emit flammable gases.

Substances which, by interaction with water, are liable to become spontaneously flammable or to give off flammable gases in dangerous quantities.

4.1.2 As referenced in this Chapter, test methods and criteria, with advice on application of the tests, are given in the current edition of the UN *Manual of Tests and Criteria*, for the classification of the following types of substances of Class 4:

- a) Flammable solids (Division 4.1);
- b) Self-reactive substances (Division 4.1);
- c) Pyrophoric solids (Division 4.2);
- d) Pyrophoric liquids (Division 4.2);
- e) Self-heating substances (Division 4.2); and
- f) Substances which, in contact with water, emit flammable gases (Division 4.3).

Test methods and criteria for self-reactive substances are given in Part II of the UN *Manual of Tests and Criteria*, and test methods and criteria for the other types of substances of Class 4 are given in Part III, section 33 of the UN *Manual of Tests and Criteria*.

4.2 FLAMMABLE SOLIDS, SELF-REACTIVE SUBSTANCES AND DESENSITIZED EXPLOSIVES

4.2.1 General

Division 4.1 includes the following types of substances:

- a) flammable solids (see 4.2.2);
- b) self-reactive substances (see 4.2.3); and
- c) solid desensitized explosives (see 4.2.4).

4.2.2 Division 4.1 — Flammable solids

4.2.2.1 Definitions and properties

4.2.2.1.1 Flammable solids are readily combustible solids and solids which may cause fire through friction.

4.2.2.1.2 Readily combustible solids are powdered, granular or pasty substances which are dangerous if they can be easily ignited by brief contact with an ignition source, such as a burning match, and if the flame spreads rapidly. The danger may not only come from the fire but also from toxic combustion products. Metal powders are especially dangerous because of the difficulty of extinguishing a fire since normal extinguishing agents such as carbon dioxide or water can increase the hazard.

4.2.2.2 Classification of flammable solids

4.2.2.2.1 Powdered, granular or pasty substances must be classified as readily combustible solids of Division 4.1 when the time of burning of one or more of the test runs, performed in accordance with the test methods and criteria in the *UN Manual of Tests and Criteria*, Part III, subsection 33.2.1, is less than 45 seconds or the rate of burning is more than 2.2 mm/s. Powders of metals or metal alloys must be classified in Division 4.1 when they can be ignited and the reaction spreads over the whole length of the sample in 10 minutes or less.

4.2.2.2.2 Solids which may cause fire through friction must be classified in Division 4.1 by analogy with existing entries (e.g. matches) until definitive criteria are established.

4.2.2.3 Assignment of packing groups

4.2.2.3.1 Packing groups are assigned on the basis of the test methods referred to in 4.2.2.2.1. For readily combustible solids (other than metal powders), Packing Group II must be assigned if the burning time is less than 45 seconds and the flame passes the wetted zone. Packing Group II must be assigned to powders of metal or metal alloys if the zone of reaction spreads over the whole length of the sample in 5 minutes or less.

4.2.2.3.2 Packing groups are assigned on the basis of the test methods referred to in 4.2.2.2.1. For readily combustible solids (other than metal powders), Packing Group III must be assigned if the burning time is less than 45 seconds and the wetted zone stops the flame propagation for at least 4 minutes. Packing Group III must be assigned to metal powders if the reaction spreads over the whole length of the sample in more than 5 minutes but not more than 10 minutes.

4.2.2.3.3 Solids which may cause fire through friction must be assigned to a packing group by analogy with existing entries or in accordance with any appropriate special provision (see Table 3-2).

4.2.3 Division 4.1 — Self-reactive substances

4.2.3.1 Definitions and properties

4.2.3.1.1 Definitions

For the purposes of these Instructions:

Self-reactive substances are thermally unstable substances liable to undergo a strongly exothermic decomposition even without the participation of oxygen (air). The following substances must not be considered to be self-reactive substances of Division 4.1 if:

- a) they are explosives according to the criteria of Class 1;

- b) they are oxidizing substances according to the classification procedure for Division 5.1 (see 5.2.1.1) except that mixtures of oxidizing substances which contain 5.0 per cent or more of combustible organic substances must be subjected to the classification procedure defined in Note 3;
- c) they are organic peroxides according to the criteria of Division 5.2;
- d) their heat of decomposition is less than 300 J/g; or
- e) their self-accelerating decomposition temperature is greater than 75°C for a 50 kg package.

Note 1.— The heat of decomposition can be determined by using any internationally recognized method, e.g. differential scanning calorimetry and adiabatic calorimetry.

Note 2. — Any substance which shows the properties of a self-reactive substance must be classified as such, even if this substance gives a positive test result, according to 4.3.2 for inclusion in Division 4.2.

Note 3.— Mixtures of oxidizing substances meeting the criteria of Division 5.1 which contain 5.0 per cent or more of combustible organic substances, which do not meet the criteria mentioned in a), c), d) or e) above, must be subjected to the self-reactive substance classification procedure.

A mixture showing the properties of a self-reactive substance, type B to F, must be classified as a self-reactive substance of Division 4.1.

A mixture showing the properties of a self-reactive substance, type G, according to the principle of 2.4.2.3.3.2 (g) of the UN Recommendations must be considered for classification as a substance of Division 5.1 (see 5.2.1.1).

4.2.3.1.2 Properties

The decomposition of self-reactive substances can be initiated by heat, contact with catalytic impurities (e.g. acids, heavy-metal compounds, bases), friction or impact. The rate of decomposition increases with temperature and varies with the substance. Decomposition, particularly if no ignition occurs, may result in the evolution of toxic gases or vapours. For certain self-reactive substances, the temperature must be controlled. Some self-reactive substances may decompose explosively, particularly if confined; this characteristic may be modified by the addition of diluents or by the use of appropriate packagings. Some self-reactive substances burn vigorously. Self-reactive substances include some of the following types of compounds:

- a) aliphatic azo compounds (—C—N=N—C—);
- b) organic azides (—C—N_3);
- c) diazonium salts ($\text{—CN}_2^+ \text{Z}^-$);
- d) N-nitroso compounds (—N—N=O); and
- e) aromatic sulphohydrazides ($\text{—SO}_2\text{—NH—NH}_2$).

This list is not exhaustive and substances with other reactive groups and some mixtures of substances may have similar properties.

4.2.3.2 Classification of self-reactive substances

4.2.3.2.1 Self-reactive substances are classified according to the degree of danger they present.

4.2.3.2.2 Related substances are specifically listed by name in the Dangerous Goods List (Table 3-1). Related substances are UN 2956, UN 3242 and UN 3251.

4.2.3.2.3 Self-reactive substances permitted for transport are listed in 4.2.3.2.4. For each permitted substance listed, the appropriate generic entry of the Dangerous Goods List (UN 3221 to 3240) is assigned, and appropriate subsidiary risks and remarks providing relevant information are given. The generic entries specify:

- the self-reactive substance type (B to F);
- the physical state (i.e. liquid/solid); and
- when temperature control is required.

4.2.3.2.4 List of currently assigned self-reactive substances in packages

≠ The following table (Table 2-6) is reproduced from 2.4.2.3.2.3 of the UN *Recommendations on the Transport of Dangerous Goods* (Eighteenth revised edition), with irrelevant material removed.

Table 2-6. List of currently assigned self-reactive substances in packages

Note.— Self-reactive substances to be transported must fulfil the classification and the control and emergency temperatures (derived from the self-accelerating decomposition temperature (SADT)) as listed.

<i>Self-reactive substance</i>	<i>Concentration (%)</i>	<i>Control temperature (°C)</i>	<i>Emergency temperature (°C)</i>	<i>UN generic entry</i>	<i>Notes</i>
Acetone-pyrogallol copolymer 2-diazo-1-naphthol-5-sulphonate	100			3228	
Azodicarbonamide formulation type B, temperature controlled	<100			FORBIDDEN	1, 2
Azodicarbonamide formulation type C	<100			3224	3
Azodicarbonamide formulation type C, temperature controlled	<100			3234	3
Azodicarbonamide formulation type D	<100			3226	4
Azodicarbonamide formulation type D, temperature controlled	<100			3236	4
2,2'-Azodi (2,4-dimethyl-4-methoxyvaleronitrile)	100	-5	+5	3236	
2,2'-Azodi (2,4-dimethyl-valeronitrile)	100	+10	+15	3236	
2,2'-Azodi (ethyl-2-methylpropionate)	100	+20	+25	3235	
1,1'-Azodi (hexahydrobenzotrile)	100			3226	
2,2'-Azodi (isobutyronitrile)	100	+40	+45	3234	
2,2'-Azodi (isobutyronitrile) as a water-based paste	≤50			3224	
2,2'-Azodi (2-methylbutyronitrile)	100	+35	+40	3236	
Benzene-1,3-disulphonyl hydrazide, as a paste	52			3226	
Benzenesulphonyl hydrazide	100			3226	
4-(Benzyl(ethyl)amino)-3-ethoxybenzenediazonium zinc chloride	100			3226	
4-(Benzyl(methyl)amino)-3-ethoxybenzenediazonium zinc chloride	100	+40	+45	3236	
3-Chloro-4-diethylaminobenzenediazonium zinc chloride	100			3226	
2-Diazo-1-naphthol-4-sulphonyl chloride	100			FORBIDDEN	2
2-Diazo-1-naphthol-5-sulphonyl chloride	100			FORBIDDEN	2
2-Diazo-1-naphthol sulphonic acid ester mixture, type D	<100			3226	7
2,5-Dibutoxy-4-(4-morpholinyl)-benzenediazonium, tetrachlorozincate (2:1)	100			3228	
2,5-Diethoxy-4-morpholinobenzenediazonium tetrafluoroborate	100	+30	+35	3236	
2,5-Diethoxy-4-morpholinobenzenediazonium zinc chloride	67-100	+35	+40	3236	
2,5-Diethoxy-4-morpholinobenzenediazonium zinc chloride	66	+40	+45	3236	
2,5-Diethoxy-4-(4-morpholinyl)-benzenediazonium sulphate	100			3226	
2,5-Diethoxy-4-(phenylsulphonyl) benzenediazonium zinc chloride	67	+40	+45	3236	
Diethyleneglycol bis (allyl carbonate) + Di-isopropyl-peroxydicarbonate	≥88 + ≤12	-10	0	3237	
2,5-Dimethoxy-4-(4-methylphenylsulphonyl) benzenediazonium zinc chloride	79	+40	+45	3236	
4-(Dimethylamino)-benzenediazonium trichlorozincate (-1)	100			3228	
4-Dimethylamino-6-(2-dimethylaminoethoxy) toluene-2-diazonium zinc chloride	100	+40	+45	3236	
N,N'-Dinitroso-N,N'-dimethyl terephthalamide, as a paste	72			3224	
N,N'-Dinitrosopentamethylenetetramine	82			3224	5
Diphenyloxide-4,4'-disulphonyl hydrazide	100			3226	
4-Dipropylaminobenzenediazonium zinc chloride	100			3226	

<i>Self-reactive substance</i>	<i>Concentration (%)</i>	<i>Control temperature (°C)</i>	<i>Emergency temperature (°C)</i>	<i>UN generic entry</i>	<i>Notes</i>
2-(n,n-Ethoxycarbonylphenylamino)-3-methoxy-4-(n-methyl-n-cyclohexylamino) benzenediazonium zinc chloride	63-92	+40	+45	3236	
2-(n,n-Ethoxycarbonylphenylamino)-3-methoxy-4-(n-methyl-n-cyclohexylamino) benzenediazonium zinc chloride	62	+35	+40	3236	
N-Formyl-2-(nitromethylene)-1,3-perhydrothiazine	100	+45	+50	3236	
2-(2-Hydroxyethoxy)-1-(pyrrolidin-1-yl) benzene-4-diazonium zinc chloride	100	+45	+50	3236	
3-(2-Hydroxyethoxy)-4-(pyrrolidin-1-yl) benzenediazonium zinc chloride	100	+40	+45	3236	
2-(n,n-Methylaminoethylcarbonyl)-4-(3,4-dimethylphenylsulphonyl) benzenediazonium hydrogen sulphate	96	+45	+50	3236	
4-Methylbenzenesulphonylhydrazide	100			3226	
3-Methyl-4-(pyrrolidin-1-yl) benzenediazonium tetrafluoroborate	95	+45	+50	3234	
4-Nitrosophenol	100	+35	+40	3236	
Self-reactive liquid, sample				3223	6
Self-reactive liquid, sample temperature controlled				3233	6
Self-reactive solid, sample				3224	6
Self-reactive solid, sample temperature controlled				3234	6
Sodium 2-diazo-1-naphthol-4-sulphonate	100			3226	
Sodium 2-diazo-1-naphthol-5-sulphonate	100			3226	
Tetramine palladium (II) nitrate	100	+30	+35	3234	

NOTES:

1. Azodicarbonamide formulations which fulfil the criteria of 2.4.2.3.3.2 (b) of the UN Recommendations.
2. "EXPLOSIVE" subsidiary risk label required and consequently forbidden for transport by air under any circumstance.
3. Azodicarbonamide formulations which fulfil the criteria of 2.4.2.3.3.2 (c) of the UN Recommendations.
4. Azodicarbonamide formulations which fulfil the criteria of 2.4.2.3.3.2 (d) of the UN Recommendations.
5. With a compatible diluent having a boiling point of not less than 150°C.
6. See 4.2.3.2.6.
7. This entry applies to mixtures of esters of 2-diazo-1-naphthol-4-sulphonic acid and 2-diazo-1-naphthol-5-sulphonic acid meeting the criteria of 2.4.2.3.3.2 d) of the UN Recommendations.

4.2.3.2.5 Classification of self-reactive substances not listed in Table 2-6 and assignment to a generic entry must be made by the appropriate authority of the State of Origin on the basis of a test report. Principles applying to the classification of such substances are provided in 2.4.2.3.3 of the UN Recommendations. The applicable classification procedures, test methods and criteria, and an example of a suitable test report, are given in the current edition of the UN *Manual of Tests and Criteria*, Part II. The statement of approval must contain the classification and the relevant transport conditions.

4.2.3.2.6 Samples of self-reactive substances not listed in Table 2-6, for which a complete set of test results is not available and which are to be transported for further testing or evaluation, may be assigned to one of the appropriate entries for self-reactive substances type C provided the following conditions are met:

- a) the available data indicate that the sample would be no more dangerous than self-reactive substances type B;
- b) the sample is packed in a combination packaging consisting of a plastic IP.2 inner packaging with a capacity not exceeding 0.5 L or 0.5 kg which is placed in a wooden box (4C1), plywood box (4D) or fibreboard box (4G) with the maximum net quantity per package not exceeding 1 L or 1 kg; and
- c) the available data indicate that the control temperature, if any, is sufficiently low to prevent any dangerous decomposition and sufficiently high to prevent any dangerous phase separation.

4.2.3.3 *Temperature control requirements*

With the exception of self-reactive solids of type B, which are forbidden for transport by air under any circumstance, self-reactive substances which require temperature control during transport are forbidden for transport by air unless exempted (see 1;1.1.2). Self-reactive substances must be subject to temperature control if their self-accelerating decomposition temperature (SADT) is less than or equal to 55°C. Test methods for determining the SADT are given in the current edition of the UN *Manual of Tests and Criteria*. The test selected must be conducted in a manner which is representative of the package to be transported both in size and material of construction.

4.2.3.4 *Desensitization of self-reactive substances*

4.2.3.4.1 In order to ensure safety in transport, self-reactive substances may be desensitized by the use of a diluent. When a diluent is used, the self-reactive substance must be tested with the diluent present in the concentration and form to be used in transport.

4.2.3.4.2 Diluents, which may allow a self-reactive substance to concentrate to a dangerous extent in the event of leakage from a package, must not be used.

4.2.3.4.3 The diluent used must be compatible with the self-reactive substance. In this regard, compatible diluents are those solids or liquids which have no detrimental influence on the thermal stability and hazard type of the self-reactive substance.

4.2.4 **Division 4.1 — Solid desensitized explosives**

4.2.4.1 *Definition*

Solid desensitized explosives are explosive substances which are wetted with water or alcohols or are diluted with other substances to form a homogeneous solid mixture to suppress their explosive properties. Entries in the Dangerous Goods List for solid desensitized explosives are UN 1310, 1320, 1321, 1322, 1336, 1337, 1344, 1347, 1348, 1349, 1354, 1355, 1356, 1357, 1517, 1571, 2555, 2556, 2557, 2852, 2907, 3317, 3319, 3344, 3364, 3365, 3366, 3367, 3368, 3369, 3370, 3376, UN 3380 and UN 3474.

4.2.4.2 Substances that:

- a) have been provisionally accepted into Class 1 according to Test Series 1 and 2 but exempted from Test Series 6;
- b) are not self-reactive substances of Division 4.1;
- c) are not substances of Class 5.

are also assigned to Division 4.1. UN 2956, UN 3241, UN 3242 and UN 3251 are such entries.

4.3 **SUBSTANCES LIABLE TO SPONTANEOUS COMBUSTION (DIVISION 4.2)**

4.3.1 **Definitions and properties**

4.3.1.1 Division 4.2 includes:

- a) pyrophoric substances: substances, including mixtures and solutions (liquid or solid), which even in small quantities ignite within 5 minutes of coming into contact with air. These substances are the most liable to spontaneous combustion and are called pyrophoric substances; and
- b) self-heating substances: other substances which in contact with air without energy supply are liable to self-heating. These substances will ignite only when in large amounts (kilograms) and after long periods of time (hours or days) and are called self-heating substances.

4.3.1.2 Self-heating of a substance is a process where the gradual reaction of that substance with oxygen (in the air) generates heat. If the rate of heat production exceeds the rate of heat loss, then the temperature of the substance will rise which, after an induction time, may lead to self-ignition and combustion.

4.3.2 Classification in Division 4.2

4.3.2.1 Solids are considered pyrophoric solids which must be classified in Division 4.2 if, in tests performed in accordance with the test method given in the current edition of the UN *Manual of Tests and Criteria*, Part III, subsection 33.3.1, the sample ignites in one of the tests.

4.3.2.2 Liquids are considered pyrophoric liquids which must be classified in Division 4.2 if, in tests performed in accordance with the test method given in the current edition of the UN *Manual of Tests and Criteria*, Part III, subsection 33.3.1.5, the liquid ignites in the first part of the test, or if it ignites or chars the filter paper.

4.3.2.3 Self-heating substances

4.3.2.3.1 A substance must be classified as a self-heating substance of Division 4.2 if, in tests performed in accordance with the test method given in the current edition of the UN *Manual of Tests and Criteria*, Part III, subsection 33.3.1.6:

- a) a positive result is obtained using a 25 mm sample cube at 140°C;
- b) a positive result is obtained in a test using a 100 mm sample cube at 140°C and a negative result is obtained in a test using a 100 mm sample cube at 120°C and the substance is to be transported in packages with a volume of more than 3 m³;
- c) a positive result is obtained in a test using a 100 mm sample cube at 140°C and a negative result is obtained in a test using a 100 mm sample cube at 100°C and the substance is to be transported in packaging with a volume of more than 450 L;
- d) a positive result is obtained in a test using a 100 mm sample cube at 140°C and a positive result is obtained using a 100 mm sample cube at 100°C.

Self-reactive substances, except for type G, which also give a positive result according to this test method must not be classified in Division 4.2 but in Division 4.1 (see 4.2.3.1.1).

4.3.2.3.2 A substance must not be classified in Division 4.2 if:

- a) a negative result is obtained in a test using a 100 mm sample cube at 140°C;
- b) a positive result is obtained in a test using a 100 mm sample cube at 140°C and a negative result is obtained in a test using a 25 mm sample cube at 140°C, a negative result is obtained in a test using a 100 mm sample cube at 120°C and the substance is to be transported in packagings with a volume of not more than 3 cubic metres; or
- c) a positive result is obtained in a test using a 100 mm sample cube at 140°C and a negative result is obtained in a test using a 25 mm sample cube at 140°C, a negative result is obtained in a test using a 100 mm sample cube at 100°C and the substance is to be transported in packagings with a volume of not more than 450 L.

4.3.3 Assignment of packing groups

4.3.3.1 Packing Group I must be assigned to all pyrophoric liquids and solids.

4.3.3.2 Packing Group II must be assigned to self-heating substances which give positive results in a test using a 25 mm sample cube at 140°C.

4.3.3.3 Packing Group III must be assigned to self-heating substances if:

- a) a positive result is obtained in a test using a 100 mm sample cube at 140°C and a negative result is obtained in a test using a 25 mm sample cube at 140°C and the substance is to be transported in packagings with a volume of more than 3 cubic metres;
- b) a positive result is obtained in a test using a 100 mm sample cube at 140°C and a negative result is obtained in a test using a 25 mm sample cube at 140°C, a positive result is obtained in a test using a 100 mm sample cube at 120°C and the substance is to be transported in packagings with a volume of more than 450 L; or
- c) a positive result is obtained in a test using a 100 mm sample cube at 140°C and a negative result is obtained in a test using a 25 mm sample cube at 140°C and a positive result is obtained in a test using a 100 mm sample cube at 100°C.

4.4 SUBSTANCES WHICH, IN CONTACT WITH WATER, EMIT FLAMMABLE GASES (DIVISION 4.3)

4.4.1 Definitions and properties

4.4.1.1 Division 4.3 — Substances which, in contact with water, emit flammable gases.

≠ 4.4.1.2 Certain substances in contact with water emit flammable gases which can form explosive mixtures with air. Such mixtures are easily ignited by all ordinary sources of ignition, for example, naked lights, sparking handtools or unprotected lamps. The resulting blast wave and flames may endanger people and the environment. The test method referred to in 4.4.2 must be used to determine whether the reaction of a substance with water leads to the development of a dangerous amount of gases which may be flammable. It must not be applied to pyrophoric substances.

4.4.2 Classification in Division 4.3

Substances which, in contact with water, emit flammable gases must be classified in Division 4.3 if, in tests performed in accordance with the test method given in the UN *Manual of Tests and Criteria*, Part III, subsection 33.4.1:

- a) spontaneous ignition takes place in any step of the test procedure; or
- b) there is an evolution of a flammable gas at a rate greater than 1 L/kg of the substance per hour.

4.4.3 Assignment of packing groups

4.4.3.1 Packing Group I must be assigned to any substance which reacts vigorously with water at ambient temperatures and demonstrates generally a tendency for the gas produced to ignite spontaneously, or which reacts readily with water at ambient temperatures such that the rate of evolution of flammable gas is equal to or greater than 10 L/kg of substance over any one minute.

4.4.3.2 Packing Group II must be assigned to any substance which reacts readily with water at ambient temperatures such that the maximum rate of evolution of flammable gas is equal to or greater than 20 L/kg of substance per hour, and which does not meet the criteria for Packing Group I.

4.4.3.3 Packing Group III must be assigned to any substance which reacts slowly with water at ambient temperatures such that the maximum rate of evolution of flammable gas is equal to or greater than 1 L/kg of substance per hour, and which does not meet the criteria for Packing Groups I or II.

4.5 CLASSIFICATION OF ORGANOMETALLIC SUBSTANCES

Depending on their properties, organometallic substances may be classified in Divisions 4.2 or 4.3, as appropriate, in accordance with the flowchart scheme given in Figure 2.4.2 of the UN *Recommendations on the Transport of Dangerous Goods*.

Chapter 5

CLASS 5 — OXIDIZING SUBSTANCES; ORGANIC PEROXIDES

INTRODUCTORY NOTE

Because of the different properties exhibited by dangerous goods within Divisions 5.1 and 5.2, it is impracticable to establish a single criterion for classification in either division. Tests and criteria for assignment to the two divisions of Class 5 are addressed in this Chapter and in the UN *Manual of Tests and Criteria*.

5.1 DEFINITIONS AND GENERAL PROVISIONS

Class 5 is divided into two divisions as follows:

a) Division 5.1 — Oxidizing substances

Substances which, in themselves are not necessarily combustible, may generally, by yielding oxygen, cause or contribute to the combustion of other material. Such substances may be contained in an article.

b) Division 5.2 — Organic peroxides

Organic substances which contain the bivalent —O—O— structure and may be considered derivatives of hydrogen peroxide, where one or both of the hydrogen atoms have been replaced by organic radicals. Organic peroxides are thermally unstable substances, which may undergo exothermic, self-accelerating decomposition. In addition, they may have one or more of the following properties:

- i) be liable to explosive decomposition;
- ii) burn rapidly;
- iii) be sensitive to impact or friction;
- iv) react dangerously with other substances;
- v) cause damage to the eyes.

5.2 OXIDIZING SUBSTANCES (DIVISION 5.1)

5.2.1 Classification in Division 5.1

5.2.1.1 Oxidizing substances are classified in Division 5.1 in accordance with the test methods, procedures and criteria in 5.2.2, 5.2.3 and the UN *Manual of Tests and Criteria*, Part III, section 34. In the event of divergence between test results and known experience, the appropriate authority of the State of Origin must be consulted to establish the appropriate classification and packing group.

Note.— Where substances of this division are listed in the Dangerous Goods List in 3;2, reclassification of those substances in accordance with these criteria need only be undertaken when this is necessary for safety.

5.2.2 Oxidizing solids

5.2.2.1 Criteria for classification in Division 5.1

- ≠ 5.2.2.1.1 Tests are performed to measure the potential for a solid substance to increase the burning rate or burning intensity of a combustible substance when the two are thoroughly mixed. The procedure is given in the UN *Manual of Tests and Criteria*, Part III, subsection 34.4.1 (test O.1) or alternatively, in subsection 34.4.3 (test O.3). Tests are conducted on the substance to be evaluated mixed with dry fibrous cellulose in mixing ratios of 1:1 and 4:1, by mass, of sample to cellulose. The burning characteristics of the mixtures are compared:

- ≠ a) in the test O.1, with the standard 3:7 mixture, by mass, of potassium bromate to cellulose. If the burning time is equal to or less than this standard mixture, the burning times should be compared with those from the Packing Group I or II reference standards, 3:2 and 2:3 ratios, by mass, of potassium bromate to cellulose, respectively; or
- + b) in the test O.3, with the standard 1:2 mixture, by mass, of calcium peroxide to cellulose. If the burning rate is equal to or greater than this standard mixture, the burning rates must be compared with those from the Packing Group I or II reference standards 3:1 and 1:1 ratios, by mass, of calcium peroxide to cellulose, respectively.

5.2.2.1.2 The classification test results are assessed on the basis of:

- ≠ a) the comparison of the mean burning time (for the test O.1) or burning rate (for the test O.3) with those of the reference mixtures; and
- b) whether the mixture of substance and cellulose ignites and burns.

5.2.2.1.3 A solid substance is classified in Division 5.1 if the 4:1 or 1:1 sample-to-cellulose ratio (by mass) tested, exhibits:

- ≠ a) in the test O.1, a mean burning time equal to or less than the mean burning time of a 3:7 mixture (by mass) of potassium bromate and cellulose; or
- + b) in the test O.3, a mean burning rate equal to or greater than the mean burning rate of a 1:2 mixture (by mass) of calcium peroxide and cellulose.

5.2.2.2 Assignment of packing groups

≠ Solid oxidizing substances are assigned to a packing group according to one of the test procedures in the UN *Manual of Tests and Criteria*, Part III, section 34.4.1 (Test O.1) or alternatively, in subsection 34.4.3 (Test O.3), in accordance with the following criteria:

- ≠ a) Test O.1:
 - i) Packing Group I: any substance which, in the 4:1 or 1:1 sample-to-cellulose ratio (by mass) tested, exhibits a mean burning time less than the mean burning time of a 3:2 mixture, by mass, of potassium bromate and cellulose;
 - ii) Packing Group II: any substance which, in the 4:1 or 1:1 sample-to-cellulose ratio (by mass) tested, exhibits a mean burning time equal to or less than the mean burning time of a 2:3 mixture (by mass) of potassium bromate and cellulose and the criteria for Packing Group I are not met;
 - iii) Packing Group III: any substance which, in the 4:1 or 1:1 sample-to-cellulose ratio (by mass) tested, exhibits a mean burning time equal to or less than the mean burning time of a 3:7 mixture (by mass) of potassium bromate and cellulose and the criteria for Packing Groups I and II are not met;
 - iv) Not Division 5.1: any substance which, in both the 4:1 and 1:1 sample-to-cellulose ratio (by mass) tested, does not ignite and burn, or exhibits mean burning times greater than that of a 3:7 mixture (by mass) of potassium bromate and cellulose.
- + b) Test O.3:
 - i) Packing Group I: any substance which, in the 4:1 or 1:1 sample-to-cellulose ratio (by mass) tested, exhibits a mean burning rate greater than the mean burning rate of a 3:1 mixture (by mass) of calcium peroxide and cellulose;
 - ii) Packing Group II: any substance which, in the 4:1 or 1:1 sample-to-cellulose ratio (by mass) tested, exhibits a mean burning rate equal to or greater than the mean burning rate of a 1:1 mixture (by mass) of calcium peroxide and cellulose, and the criteria for Packing Group I are not met;
 - iii) Packing Group III: any substance which, in the 4:1 or 1:1 sample-to-cellulose ratio (by mass) tested, exhibits a mean burning rate equal to or greater than the mean burning rate of a 1:2 mixture (by mass) of calcium peroxide and cellulose, and the criteria for Packing Groups I and II are not met;
 - iv) Not Division 5.1: any substance which, in both the 4:1 and 1:1 sample-to-cellulose ratio (by mass) tested, does not ignite and burn, or exhibits a mean burning rate less than the mean burning rate of a 1:2 mixture (by mass) of calcium peroxide and cellulose.

5.2.3 Oxidizing liquids

5.2.3.1 *Criteria for classification in Division 5.1*

≠ A test is performed to determine the potential for a liquid substance to increase the burning rate or burning intensity of a combustible substance or for spontaneous ignition to occur when the two are thoroughly mixed. The procedure is given in the UN *Manual of Tests and Criteria*, Part III, subsection 34.4.2 (Test O.2). It measures the pressure rise time during combustion. Whether a liquid is an oxidizing substance of Division 5.1 and, if so, whether Packing Group I, II or III must be assigned, is decided on the basis of the test result (see also precedence of hazards characteristics).

5.2.3.1.2 The classification test results are assessed on the basis of:

- a) whether the mixture of substance and cellulose spontaneously ignites;
- b) the comparison of the mean time taken for the pressure to rise from 690 kPa to 2 070 kPa gauge with those of the reference substances.

5.2.3.1.3 A liquid substance is classified in Division 5.1 if the 1:1 mixture, by mass, of substance and cellulose tested, exhibits a mean pressure rise time less than or equal to the mean pressure rise time of a 1:1 mixture, by mass, of 65 per cent aqueous nitric acid and cellulose.

5.2.3.2 Assignment of packing groups

Liquid oxidizing substances are assigned to a packing group according to the test procedure in the UN *Manual of Tests and Criteria*, Part III, section 34.4.2, in accordance with the following criteria:

- Packing Group I: any substance which, in the 1:1 mixture, by mass, of substance and cellulose tested, spontaneously ignites; or the mean pressure rise time of a 1:1 mixture, by mass, of substance and cellulose is less than that of a 1:1 mixture, by mass, of 50 per cent perchloric acid and cellulose.
- Packing Group II: any substance which, in the 1:1 mixture, by mass, of substance and cellulose tested, exhibits a mean pressure rise time less than or equal to the mean pressure rise time of a 1:1 mixture, by mass, of 40 per cent aqueous sodium chlorate solution and cellulose; and the criteria for Packing Group I are not met.
- Packing Group III: any substance which, in the 1:1 mixture, by mass, of substance and cellulose tested, exhibits a mean pressure rise time less than or equal to the mean pressure rise time of a 1:1 mixture, by mass, of 65 per cent aqueous nitric acid and cellulose; and the criteria for Packing Groups I and II are not met.
- Not Division 5.1: any substance which, in the 1:1 mixture, by mass, of substance and cellulose tested, exhibits a pressure rise of less than 2 070 kPa gauge; or exhibits a mean pressure rise time greater than the mean pressure rise time of a 1:1 mixture, by mass, of 65 per cent aqueous nitric acid and cellulose.

5.3 ORGANIC PEROXIDES (DIVISION 5.2)

5.3.1 Properties

5.3.1.1 Organic peroxides are liable to exothermic decomposition which can be started by heat, contact with impurities (e.g. acids, heavy metal compounds, amines), friction or impact. The rate of decomposition increases with temperature and varies with the peroxide formulation. Decomposition may result in the evolution of harmful or flammable gases or vapours. For certain organic peroxides the temperature must be controlled during transport. Some organic peroxides decompose explosively, particularly if confined. This characteristic may be modified by the addition of diluents or by the use of appropriate packagings. Many organic peroxides burn vigorously.

5.3.1.2 Contact of organic peroxides with the eyes should be avoided. Some organic peroxides will cause serious injury to the cornea, even after brief contact, or will be corrosive to the skin.

5.3.2 Classification of organic peroxides

5.3.2.1 Any organic peroxide must be considered for classification in Division 5.2 unless the organic peroxide formulation contains:

- a) not more than 1.0 per cent available oxygen from the organic peroxides when containing not more than 1.0 per cent hydrogen peroxide; or
- b) not more than 0.5 per cent available oxygen from the organic peroxides when containing more than 1.0 per cent but not more than 7.0 per cent hydrogen peroxide.

Note.— The available oxygen content (per cent) of an organic peroxide formulation is given by the formula

$$16 \times \sum (n_i \times c_i / m_i)$$

where n_i = number of peroxygen groups per molecule of organic peroxide i ;

c_i = concentration (mass in percentage) of organic peroxide i ; and

m_i = molecular mass of organic peroxide i .

5.3.2.2 Organic peroxides are classified according to the degree of danger they present.

5.3.2.3 Organic peroxides permitted for transport are listed in 5.3.2.4. For each permitted substance, Table 2-7 assigns the appropriate generic entry in the Dangerous Goods List (UN 3103 to 3120) and provides relevant information. The generic entries specify:

- a) organic peroxide type (B to F);
- b) physical state (liquid or solid); and
- c) temperature control, when required (see 5.3.3).

5.3.2.3.1 Mixtures of the listed formulations may be classified as the same type of organic peroxide as that of the most dangerous component and be transported under the conditions of transport given for this type. However, as two stable components can form a thermally less stable mixture, the self-accelerating decomposition temperature (SADT) of the mixture must be determined and, if necessary, temperature control applied as required by 5.3.3.

5.3.2.4 *List of currently assigned organic peroxides*

≠ The following table (Table 2-7) is reproduced from 2.5.3.2.4 of the UN *Recommendations on the Transport of Dangerous Goods* (Eighteenth revised edition), with irrelevant material removed.

5.3.2.5 Classification of organic peroxides not listed in 5.3.2.4 and assignment to a generic entry must be made by the appropriate authority of the State of Origin on the basis of a test report. Principles applying to the classification of such substances are provided in 2.5.3.3 of the UN Recommendations. The applicable classification procedures, test methods and criteria, and an example of a suitable test report, are given in the current edition of the UN *Manual of Tests and Criteria*, Part II. The statement of approval must contain the classification and the relevant transport conditions.

5.3.2.6 Samples of new formulations of organic peroxides not listed in 5.3.2.4 for which complete test data are not available and which are to be transported for further testing or evaluation may be assigned to one of the appropriate entries for **Organic peroxide Type C** provided that the following conditions are met:

- a) the available data indicate that the sample would be no more dangerous than organic peroxide type B;
- b) it is packed in a combination packaging consisting of a plastic IP.2 inner packaging with a capacity not exceeding 0.5 L or 0.5 kg which is placed in a wooden box (4C1), plywood box (4D) or fibreboard box (4G) with the maximum net quantity per package not exceeding 1 L or 1 kg; and
- c) the available data indicate that the control temperature, if any, is sufficiently low to prevent any dangerous decomposition and sufficiently high to prevent any dangerous phase separation.

5.3.3 Temperature control requirements

5.3.3.1 An organic peroxide formulation must be regarded as possessing explosive properties when, in laboratory testing, the formulation is liable to detonate, to deflagrate rapidly or to show a violent effect when heated under confinement. With the exception of organic peroxides of type B, which are forbidden for transport by air under any circumstance, organic peroxides requiring temperature control during transport are forbidden for transport by air unless exempted (see 1;1.1.2).

5.3.3.2 The following organic peroxides must be subjected to temperature control during carriage:

- a) organic peroxides types B and C with an SADT $\leq 50^{\circ}\text{C}$;
- b) organic peroxides type D showing a medium effect when heated under confinement with an SADT $\leq 50^{\circ}\text{C}$ or showing a low or no effect when heated under confinement with an SADT $\leq 45^{\circ}\text{C}$; and
- c) organic peroxides types E and F with an SADT $\leq 45^{\circ}\text{C}$.

5.3.3.3 Test methods for determining the SADT are given in the UN *Manual of Tests and Criteria*, Part III, section 28. The test selected must be conducted in a manner which is representative of the package to be transported.

5.3.3.4 Test methods for determining the flammability are given in the UN *Manual of Tests and Criteria*, Part III, subsection 32.4.

5.3.4 Desensitization of organic peroxides

5.3.4.1 In order to ensure safety during transport, organic peroxides are, in many cases, desensitized by organic liquids or solids, inorganic solids or water. Where a percentage of a substance is stipulated, this refers to the percentage by mass, rounded to the nearest whole number. In general, desensitization should be such that in case of spillage or fire, the organic peroxide may not concentrate to a dangerous extent.

5.3.4.2 Unless otherwise stated for the individual organic peroxide formulation, the following definitions apply for diluents used for desensitization:

- a) *Diluents type A* are organic liquids which are compatible with the organic peroxide and which have a boiling point of not less than 150°C. Type A diluents may be used for desensitizing all organic peroxides;
- b) *Diluents type B* are organic liquids which are compatible with the organic peroxide and which have a boiling point of less than 150°C but not less than 60°C and a flash point of not less than 5°C. Type B diluents may be used for desensitization of all provided that the boiling point of the liquid is at least 60°C higher than the SADT in a 50 kg package.

5.3.4.3 Diluents, other than type A or type B, may be added to organic peroxide formulations as listed in Table 2-7 provided that they are compatible. However, replacement of all or part of a type A or type B diluent by another diluent with differing properties requires that the organic peroxide formulation be reassessed in accordance with the normal acceptance procedure for Division 5.2.

5.3.4.4 Water may only be used for the desensitization of organic peroxides which are shown in Table 2-7 or in the statement of approval according to 5.3.2.5 with the approval of the appropriate authority of the State of Manufacture or when the organic peroxide formulation is specified as being with water or as a stable dispersion in water.

5.3.4.5 Organic and inorganic solids may be used for desensitization of organic peroxides provided that they are compatible.

5.3.4.6 Compatible liquids and solids are those which have no detrimental influence on the thermal stability and hazard type of the organic peroxide formulation.

Table 2-7. List of currently assigned organic peroxides in packages

Note.— Peroxides to be transported must fulfil the classification and the control and emergency temperatures (derived from the self-accelerating decomposition temperature (SADT)) as listed.

<i>Organic peroxide</i>	<i>Concentration (per cent)</i>	<i>Diluent type A (per cent)</i>	<i>Diluent type B (per cent) (Note 1)</i>	<i>Inert solid (per cent)</i>	<i>Water (per cent)</i>	<i>Control tempera- ture (°C)</i>	<i>Emergency tempera- ture (°C)</i>	<i>UN generic entry</i>	<i>Notes</i>
Acetyl acetone peroxide	≤42	≥48			≥8			3105	2
Acetyl acetone peroxide	≤32 as a paste							3106	20
Acetyl cyclohexanesulphonyl peroxide	≤82				≥12	-10	0	FORBIDDEN	3
Acetyl cyclohexanesulphonyl peroxide	≤32		≥68			-10	0	3115	
tert-Amyl hydroperoxide	≤88	≥6			≥6			3107	
tert-Amyl peroxyacetate	≤62	≥38						3105	
tert-Amyl peroxybenzoate	≤100							3103	
tert-Amyl peroxy-2-ethylhexanoate	≤100					+20	+25	3115	
tert-Amyl peroxy-2-ethylhexyl carbonate	≤100							3105	
tert-Amylperoxy isopropyl carbonate	≤77	≥23						3103	
tert-Amyl peroxyneodecanoate	≤77		≥23			0	+10	3115	
tert-Amyl peroxyneodecanoate	≤47	≥53				0	+10	3119	
tert-Amyl peroxy-pivalate	≤77		≥23			+10	+15	3113	
tert-Amylperoxy-3,5,5-trimethylhexanoate	≤100							FORBIDDEN	
tert-Butyl cumyl peroxide	>42-100							3107	
tert-Butyl cumyl peroxide	≤52			≥48				3108	

<i>Organic peroxide</i>	<i>Concentration (per cent)</i>	<i>Diluent type A (per cent)</i>	<i>Diluent type B (per cent) (Note 1)</i>	<i>Inert solid (per cent)</i>	<i>Water (per cent)</i>	<i>Control tempera- ture (°C)</i>	<i>Emergency tempera- ture (°C)</i>	<i>UN generic entry</i>	<i>Notes</i>
n-Butyl-4,4-di-(tert-butylperoxy) valerate	>52-100							3103	
n-Butyl-4,4-di-(tert-butylperoxy) valerate	≤52			≥48				3108	
tert-Butyl hydroperoxide	>79-90				≥10			3103	13
tert-Butyl hydroperoxide	≤80	≥20						3105	4,13
tert-Butyl hydroperoxide	≤79				>14			3107	13,23
tert-Butyl hydroperoxide	≤72				≥28			3109	13
tert-Butyl hydroperoxide + Di-tert-butylperoxide	<82 + >9				≥7			3103	13
tert-Butyl monoperoxy maleate	>52-100							FORBIDDEN	3
tert-Butyl monoperoxy maleate	≤52	≥48						3103	
tert-Butyl monoperoxy maleate	≤52			≥48				3108	
tert-Butyl monoperoxy maleate	≤52 as a paste							3108	
tert-Butyl peroxyacetate	>52-77	≥23						FORBIDDEN	3
tert-Butyl peroxyacetate	>32-52	≥48						3103	
tert-Butyl peroxyacetate	≤32		≥68					3109	
tert-Butyl peroxybenzoate	>77-100							3103	
tert-Butyl peroxybenzoate	>52-77	≥23						3105	
tert-Butyl peroxybenzoate	≤52			≥48				3106	
tert-Butyl peroxybutyl fumarate	≤52	≥48						3105	
tert-Butyl peroxy crotonate	≤77	≥23						3105	
tert-Butyl peroxydiethylacetate	≤100					+20	+25	3113	
tert-Butyl peroxy-2-ethylhexanoate	>52-100					+20	+25	3113	
tert-Butyl peroxy-2-ethylhexanoate	>32-52		≥48			+30	+35	3117	
tert-Butyl peroxy-2-ethylhexanoate	≤52			≥48		+20	+25	3118	
tert-Butyl peroxy-2-ethylhexanoate	≤32		≥68			+40	+45	3119	
tert-Butyl peroxy-2-ethylhexanoate + 2,2-Di-(tert-butylperoxy) butane	≤12 + ≤14	≥14		≥60				3106	
tert-Butyl peroxy-2-ethylhexanoate + 2,2-Di-(tert-butylperoxy) butane	≤31 + ≤36	≥14	≥33			+35	+40	3115	
tert-Butyl peroxy-2-ethylhexylcarbonate	≤100							3105	
tert-Butyl peroxyisobutyrate	>52-77		≥23			+15	+20	FORBIDDEN	3
tert-Butyl peroxyisobutyrate	≤52		≥48			+15	+20	3115	
tert-Butylperoxy isopropylcarbonate	≤77	≥23						3103	
1-(2-tert-Butylperoxy isopropyl)-3-isopropenylbenzene	≤77	≥23						3105	
1-(2-tert-Butylperoxy isopropyl)-3-isopropenylbenzene	≤42			≥58				3108	
tert-Butyl peroxy-2-methylbenzoate	≤100							3103	
tert-Butyl peroxyneodecanoate	>77-100					-5	+5	3115	
tert-Butyl peroxyneodecanoate	≤77		≥23			0	+10	3115	
tert-Butyl peroxyneodecanoate	≤52 as a stable dispersion in water					0	+10	3119	

<i>Organic peroxide</i>	<i>Concentration (per cent)</i>	<i>Diluent type A (per cent)</i>	<i>Diluent type B (per cent) (Note 1)</i>	<i>Inert solid (per cent)</i>	<i>Water (per cent)</i>	<i>Control tempera- ture (°C)</i>	<i>Emergency tempera- ture (°C)</i>	<i>UN generic entry</i>	<i>Notes</i>
tert-Butyl peroxyneodecanoate	≤42 as a stable dispersion in water (frozen)					0	+10	3118	
tert-Butyl peroxyneodecanoate	≤32	≥68				0	+10	3119	
tert-Butyl peroxyneohexanoate	≤77	≥23				0	+10	3115	
tert-Butyl peroxyneohexanoate	≤42 as a stable dispersion in water					0	+10	3117	
tert-Butyl peroxyvalerate	>67-77	≥23				0	+10	3113	
tert-Butyl peroxyvalerate	>27-67		≥33			0	+10	3115	
tert-Butyl peroxyvalerate	≤27		≥73			+30	+35	3119	
tert-Butylperoxy stearylcarbonate	≤100							3106	
tert-Butyl peroxy-3,5,5-trimethylhexanoate	>32-100							3105	
tert-Butyl peroxy-3,5,5-trimethylhexanoate	≤42			≥58				3106	
tert-Butyl peroxy-3,5,5-trimethylhexanoate	≤32		≥68					3109	
3-Chloroperoxybenzoic acid	>57-86			≥14				FORBIDDEN	3
3-Chloroperoxybenzoic acid	≤57			≥3	≥40			3106	
3-Chloroperoxybenzoic acid	≤77			≥6	≥17			3106	
Cumyl hydroperoxide	>90-98	≤10						3107	13
Cumyl hydroperoxide	≤90	≤10						3109	13,18
Cumyl peroxyneodecanoate	≤77		≥23			-10	0	3115	
Cumyl peroxyneodecanoate	≤87	≥13				-10	0	3115	
Cumyl peroxyneodecanoate	≤52 as a stable dispersion in water					-10	0	3119	
Cumyl peroxyneohexanoate	≤77	≥23				-10	0	3115	
Cumyl peroxyvalerate	≤77		≥23			-5	+5	3115	
Cyclohexanone peroxide(s)	≤91				≥9			3104	13
Cyclohexanone peroxide(s)	≤72	≥28						3105	5
Cyclohexanone peroxide(s)	≤72 as a paste							3106	5,20
Cyclohexanone peroxide(s)	≤32			≥68				Exempt	29
+ ([3r-(3r,5as,6s,8as,9r,10r,12s,12ar**)]-Decahydro-10-methoxy-3,6,9-trimethyl-3,12-epoxy-12h-pyrano[4,3-j]-1,2-benzodioxepin)	≤100							3106	
Diacetone alcohol peroxides	≤57		≥26		≥8	+40	+45	3115	6
Diacetyl peroxide	≤27		≥73			+20	+25	3115	7,13
Di-tert-amyl peroxide	≤100							3107	
1,1-Di-(tert-amylperoxy) cyclohexane	≤82	≥18						3103	
Dibenzoyl peroxide	>51-100			≤48				FORBIDDEN	3
Dibenzoyl peroxide	>77-94				≥6			FORBIDDEN	3
Dibenzoyl peroxide	≤77				≥23			3104	

<i>Organic peroxide</i>	<i>Concentration (per cent)</i>	<i>Diluent type A (per cent)</i>	<i>Diluent type B (per cent) (Note 1)</i>	<i>Inert solid (per cent)</i>	<i>Water (per cent)</i>	<i>Control tempera- ture (°C)</i>	<i>Emergency tempera- ture (°C)</i>	<i>UN generic entry</i>	<i>Notes</i>
Dibenzoyl peroxide	≤62			≥28	≥10			3106	
Dibenzoyl peroxide	>52-62 as a paste							3106	20
Dibenzoyl peroxide	>35-52			≥48				3106	
Dibenzoyl peroxide	>36-42	≥18			≤40			3107	
Dibenzoyl peroxide	≤56.5 as a paste				≥15			3108	
Dibenzoyl peroxide	≤52 as a paste							3108	20
Dibenzoyl peroxide	≤42 as a stable dispersion in water							3109	
Dibenzoyl peroxide	≤35			≥65				Exempt	29
Di-(4-tert-butylcyclohexyl) peroxydicarbonate	≤100					+30	+35	3114	
Di-(4-tert-butylcyclohexyl) peroxydicarbonate	≤42 as a stable dispersion in water					+30	+35	3119	
Di-tert-butyl peroxide	>52-100							3107	
Di-tert-butyl peroxide	≤52	≥48						3109	25
Di-tert-butyl peroxyazolate	≤52	≥48						3105	
2,2-Di-(tert-amylperoxy)butane	≤57	≥43						3105	
2,2-Di-(tert-butylperoxy)butane	≤52	≥48						3103	
1,6-Di-(tert-butylperoxycarbonyloxy) hexane	≤72	≥28						3103	
1,1-Di-(tert-butylperoxy)cyclohexane	>80-100							FORBIDDEN	3
1,1-Di-(tert-butylperoxy)cyclohexane	>52-80	≥20						3103	
1,1-Di-(tert-butylperoxy)cyclohexane	≤72		≥28					3103	30
1,1-Di-(tert-butylperoxy)cyclohexane	>42-52	≥48						3105	
1,1-Di-(tert-butylperoxy)cyclohexane	≤42	≥13		≥45				3106	
1,1-Di-(tert-butylperoxy)cyclohexane	≤42	≥58						3109	
1,1-Di-(tert-butylperoxy)cyclohexane	≤27	≥25						3107	21
1,1-Di-(tert-butylperoxy)cyclohexane	≤13	≥13	≥74					3109	
1,1-Di-(tert-butylperoxy)cyclohexane + tert- butyl peroxy-2-ethylhexanoate	≤43+≤16	≥41						3105	
1,1-Di-(tert-butylperoxy)-3,3,5- trimethylcyclohexane	≤90		≥10					3103	30
Di-n-butyl peroxydicarbonate	>27-52		≥48			-15	-5	3115	
Di-n-butyl peroxydicarbonate	≤42 as a stable dispersion in water (frozen)					-15	-5	3118	
Di-n-butyl peroxydicarbonate	≤27		≥73			-10	0	3117	
Di-sec-butyl peroxydicarbonate	>52-100					-20	-10	3113	
Di-sec-butyl peroxydicarbonate	≤52		≥48			-15	-5	3115	
Di-(tert-butylperoxyisopropyl) benzene(s)	>42-100			≤57				3106	

<i>Organic peroxide</i>	<i>Concentration (per cent)</i>	<i>Diluent type A (per cent)</i>	<i>Diluent type B (per cent) (Note 1)</i>	<i>Inert solid (per cent)</i>	<i>Water (per cent)</i>	<i>Control tempera- ture (°C)</i>	<i>Emergency tempera- ture (°C)</i>	<i>UN generic entry</i>	<i>Notes</i>
Di-(tert-butylperoxyisopropyl) benzene(s)	≤42			≥58				Exempt	29
Di-(tert-butylperoxy)phthalate	>42-52	≥48						3105	
Di-(tert-butylperoxy)phthalate	≤52 as a paste							3106	20
Di-(tert-butylperoxy)phthalate	≤42	≥58						3107	
2,2-Di-(tert-butylperoxy)propane	≤52	≥48						3105	
2,2-Di-(tert-butylperoxy)propane	≤42	≥13		≥45				3106	
1,1-Di-(tert-butylperoxy)-3,3,5-trimethylcyclohexane	>90-100							FORBIDDEN	3
1,1-Di-(tert-butylperoxy)-3,3,5-trimethylcyclohexane	>57-90	≥10						3103	
1,1-Di-(tert-butylperoxy)-3,3,5-trimethylcyclohexane	≤77		≥23					3103	
1,1-Di-(tert-butylperoxy)-3,3,5-trimethylcyclohexane	≤57			≥43				3110	
1,1-Di-(tert-butylperoxy)-3,3,5-trimethylcyclohexane	≤57	≥43						3107	
1,1-Di-(tert-butylperoxy)-3,3,5-trimethylcyclohexane	≤32	≥26	≥42					3107	
Dicetyl peroxydicarbonate	≤100					+30	+35	3116	
Dicetyl peroxydicarbonate	≤42 as a stable dispersion in water					+30	+35	3119	
Di-4-chlorobenzoyl peroxide	≤77				≥23			FORBIDDEN	3
Di-4-chlorobenzoyl peroxide	≤52 as a paste							3106	20
Di-4-chlorobenzoyl peroxide	≤32			≥68				Exempt	29
Dicumyl peroxide	>52-100							3110	12
Dicumyl peroxide	≤52			≥48				Exempt	29
Dicyclohexyl peroxydicarbonate	>91-100					+10	+15	FORBIDDEN	3
Dicyclohexyl peroxydicarbonate	≤91				≥9	+10	+15	3114	
Dicyclohexyl peroxydicarbonate	≤42 as a stable dispersion in water					+15	+20	3119	
Didecanoyl peroxide	≤100					+30	+35	3114	
2,2-Di-(4,4-di(tert-butylperoxy)cyclohexyl)propane	≤42			≥58				3106	
2,2-Di-(4,4-Di-(tert-butylperoxy)cyclohexyl)propane	≤22		≥78					3107	
Di-2,4-dichlorobenzoyl peroxide	≤77				≥23			FORBIDDEN	3
Di-2,4-dichlorobenzoyl peroxide	≤52 as a paste with silicon oil							3106	
Di-2,4-dichlorobenzoyl peroxide	≤52 as a paste					+20	+25	3118	
Di-(2-ethoxyethyl) peroxydicarbonate	≤52		≥48			-10	0	3115	
Di-(2-ethylhexyl)peroxydicarbonate	>77-100					-20	-10	3113	
Di-(2-ethylhexyl)peroxydicarbonate	≤77		≥23			-15	-5	3115	

<i>Organic peroxide</i>	<i>Concentration (per cent)</i>	<i>Diluent type A (per cent)</i>	<i>Diluent type B (per cent) (Note 1)</i>	<i>Inert solid (per cent)</i>	<i>Water (per cent)</i>	<i>Control tempera- ture (°C)</i>	<i>Emergency tempera- ture (°C)</i>	<i>UN generic entry</i>	<i>Notes</i>
Di-(2-ethylhexyl)peroxydicarbonate	≤62 as a stable dispersion in water					-15	-5	3119	
Di-(2-ethylhexyl)peroxydicarbonate	≤52 as a stable dispersion in water (frozen)					-15	-5	3120	
2,2-Dihydroperoxypropane	≤27			≥73				FORBIDDEN	3
Di-(1-hydroxycyclohexyl)peroxide	≤100							3106	
Diisobutyl peroxide	>32-52		≥48			-20	-10	FORBIDDEN	3
Diisobutyl peroxide	≤32		≥68			-20	-10	3115	
Diisopropylbenzene dihydroperoxide	≤82	≥5			≥5			3106	24
Diisopropyl peroxydicarbonate	>52-100					-15	-5	FORBIDDEN	3
Diisopropyl peroxydicarbonate	≤52		≥48			-20	-10	3115	
Diisopropyl peroxydicarbonate	≤32	≥68				-15	-5	3115	
Dilauroyl peroxide	≤100							3106	
Dilauroyl peroxide	≤42 as a stable dispersion in water							3109	
Di-(3-methoxybutyl) peroxydicarbonate	≤52		≥48			-5	5	3115	
Di-(2-methylbenzoyl) peroxide	≤87				≥13	+30	+35	FORBIDDEN	3
Di-(3-methylbenzoyl) peroxide + Benzoyl (3-methylbenzoyl) peroxide + dibenzoyl peroxide	≤20+≤18+≤4		≥58			35	40	3115	
Di-(4-methylbenzoyl) peroxide	≤52 as a paste with silicon oil							3106	
2,5-Dimethyl-2,5-di-(benzoylperoxy)hexane	>82-100							FORBIDDEN	3
2,5-Dimethyl-2,5-di-(benzoylperoxy)hexane	≤82			≥18				3106	
2,5-Dimethyl-2,5-di-(benzoylperoxy)hexane	≤82				≥18			3104	
2,5-Dimethyl-2,5-di-(tert-butylperoxy)hexane	>90-100							3103	
2,5-Dimethyl-2,5-di-(tert-butylperoxy)hexane	>52-90	≥10						3105	
2,5-Dimethyl-2,5-di-(tert-butylperoxy)hexane	≤77			≥23				3108	
2,5-Dimethyl-2,5-di-(tert-butylperoxy)hexane	≤52	≥48						3109	
2,5-Dimethyl-2,5-di-(tert-butylperoxy)hexane	≤47 as a paste							3108	
2,5-Dimethyl-2,5-di-(tert-butylperoxy)hexyne-3	>86-100							FORBIDDEN	3
2,5-Dimethyl-2,5-di-(tert-butylperoxy)hexyne-3	>52-86	≥14						3103	26
2,5-Dimethyl-2,5-di-(tert-butylperoxy)hexyne-3	≤52			≥48				3106	
2,5-Dimethyl-2,5-di-(2-ethylhexanoylperoxy)hexane	≤100					+20	+25	3113	
2,5-Dimethyl-2,5-dihydroperoxyhexane	≤82				≥18			3104	
2,5-Dimethyl-2,5-di-(3,5,5-trimethylhexanoylperoxy)hexane	≤77	≥23						3105	
1,1-Dimethyl-3-hydroxybutyl peroxyneohexanoate	≤52	≥48				0	+10	3117	
Dimyristyl peroxydicarbonate	≤100					+20	+25	3116	

<i>Organic peroxide</i>	<i>Concentration (per cent)</i>	<i>Diluent type A (per cent)</i>	<i>Diluent type B (per cent) (Note 1)</i>	<i>Inert solid (per cent)</i>	<i>Water (per cent)</i>	<i>Control tempera- ture (°C)</i>	<i>Emergency tempera- ture (°C)</i>	<i>UN generic entry</i>	<i>Notes</i>
Dimyristyl peroxydicarbonate	≤42 as a stable dispersion in water					+20	+25	3119	
Di-(2-neodecanoylperoxyisopropyl) benzene	≤52	≥48				-10	0	3115	
Di-n-nonanoyl peroxide	≤100					0	+10	3116	
Di-n-octanoyl peroxide	≤100					+10	+15	3114	
Di-(2-phenoxyethyl)peroxydicarbonate	>85-100							FORBIDDEN	3
Di-(2-phenoxyethyl)peroxydicarbonate	≤85				≥15			3106	
Dipropionyl peroxide	≤27		≥73			+15	+20	3117	
Di-n-propyl peroxydicarbonate	≤100					-25	-15	3113	
Di-n-propyl peroxydicarbonate	≤77	≥23				-20	-10	3113	
Disuccinic acid peroxide	>72-100							FORBIDDEN	3,17
Disuccinic acid peroxide	≤72				≥28	+10	+15	3116	
Di-(3,5,5-trimethylhexanoyl) peroxide	>38-82	≥18				0	+10	3115	
Di-(3,5,5-trimethylhexanoyl) peroxide	≤52 as a stable dispersion in water					+10	+15	3119	
Di-(3,5,5-trimethylhexanoyl) peroxide	≤38	≥62				+20	+25	3119	
Ethyl 3,3-di-(tert-amyloxy)butyrate	≤67	≥33						3105	
Ethyl 3,3-di-(tert-butylperoxy)butyrate	>77-100							3103	
Ethyl 3,3-di-(tert-butylperoxy)butyrate	≤77	≥23						3105	
Ethyl 3,3-di-(tert-butylperoxy)butyrate	≤52			≥48				3106	
1-(2-Ethylhexanoyloxy)-1,3-dimethylbutyl peroxypivalate	≤52	≥45	≥10			-20	-10	3115	
tert-Hexyl Peroxyneodecanoate	≤71	≥29				0	+10	3115	
tert-Hexyl Peroxypivalate	≤72		≥28			+10	+15	3115	
3-Hydroxy-1,1-dimethylbutyl peroxyneodecanoate	≤77	≥23				-5	+5	3115	
3-Hydroxy-1,1-dimethylbutyl peroxyneodecanoate	≤52 as a stable dispersion in water					-5	+5	3119	
3-Hydroxy-1,1-dimethylbutyl peroxyneodecanoate	≤52	≥48				-5	+5	3117	
Isopropyl sec-butyl peroxydicarbonate +di-sec- butyl peroxydicarbonate +di-isopropyl peroxydicarbonate	≤32 + ≤15-18 + ≤12-15	≥38				-20	-10	3115	
Isopropyl sec-butyl peroxydicarbonate +di-sec- butyl peroxydicarbonate +di-isopropyl peroxydicarbonate	≤52 + ≤28 + ≤22					-20	-10	FORBIDDEN	3
Isopropylcumyl hydroperoxide	≤72	≥28						3109	13
p-Menthyl hydroperoxide	>72-100							3105	13
p-Menthyl hydroperoxide	≤72	≥28						3109	27
Methylcyclohexanone peroxide(s)	≤67		≥33			+35	+40	3115	
Methyl ethyl ketone peroxide(s)	see remark 8)	≥48						FORBIDDEN	3,8,13

<i>Organic peroxide</i>	<i>Concentration (per cent)</i>	<i>Diluent type A (per cent)</i>	<i>Diluent type B (per cent) (Note 1)</i>	<i>Inert solid (per cent)</i>	<i>Water (per cent)</i>	<i>Control tempera- ture (°C)</i>	<i>Emergency tempera- ture (°C)</i>	<i>UN generic entry</i>	<i>Notes</i>
Methyl ethyl ketone peroxide(s)	see remark 9)	≥55						3105	9
Methyl ethyl ketone peroxide(s)	see remark 10)	≥60						3107	10
Methyl isobutyl ketone peroxide(s)	≤62	≥19						3105	22
Methyl isopropyl ketone peroxide(s)	see remark 31)	≥70						3109	31
Organic peroxide, liquid, sample								3103	11
Organic peroxide, liquid, sample, temperature controlled								3113	11
Organic peroxide, solid, sample								3104	11
Organic peroxide, solid, sample, temperature controlled								3114	11
3,3,5,7,7-pentamethyl-1,2,4-trioxepane	≤100							3107	
Peroxyacetic acid, type D, stabilized	≤43							3105	13,14, 19
Peroxyacetic acid, type E, stabilized	≤43							3107	13,15, 19
Peroxyacetic acid, type F, stabilized	≤43							3109	13,16, 19
Peroxyauric acid	≤100					+35	+40	3118	
Pinanyl hydroperoxide	>56-100							3105	13
Pinanyl hydroperoxide	≤56	≥44						3109	
Polyether poly-tert-butylperoxycarbonate	≤52		≥23					3107	
1,1,3,3-Tetramethylbutyl hydroperoxide	≤100							3105	
1,1,3,3-Tetramethylbutylperoxy-2 ethylhexanoate	≤100					+15	+20	3115	
1,1,3,3-Tetramethylbutyl peroxyneodecanoate	≤72		≥28			-5	+5	3115	
1,1,3,3-Tetramethylbutyl peroxyneodecanoate	≤52 as a stable dispersion in water					-5	+5	3119	
1,1,3,3-Tetramethylbutylperoxypivalate	≤77	≥23				0	+10	3315	
3,6,9-Triethyl-3,6,9-trimethyl-1,4,7 triperoxonane	≤17	≥18		≥65				3110	
3,6,9-Triethyl-3,6,9-trimethyl-1,4,7-triperoxonane	≤42	≥58						3105	28

Notes:

- Diluent type B may always be replaced by diluent type A. Boiling point diluent type B should be at least 60°C higher than the SADT of the organic peroxide.
- Available oxygen ≤4.7 per cent.
- "EXPLOSIVE" subsidiary risk label required and consequently forbidden for transport by air under any circumstance.
- Diluent may be replaced by Di-tert-butyl peroxide.
- Available oxygen ≤9 per cent.
- With ≤9 per cent hydrogen peroxide; available oxygen ≤10 per cent.
- Only non-metallic packagings allowed.
- Available oxygen >10 per cent and ≤10.7 per cent, with or without water.
- Available oxygen ≤10 per cent, with or without water.
- Available oxygen ≤8.2 per cent, with or without water.
- See 5.3.2.6.
- Not used.
- "CORROSIVE" subsidiary risk label required (see Figure 5-22).
- Peroxyacetic acid formulations which fulfil the criteria of 5.3.2.5.

15. Peroxyacetic acid formulations which fulfil the criteria of 5.3.2.5.
 16. Peroxyacetic acid formulations which fulfil the criteria of 5.3.2.5.
 17. Addition of water to this organic peroxide will decrease its thermal stability.
 18. No "CORROSIVE" subsidiary risk label required for concentrations below 80 per cent.
 19. Mixtures with hydrogen peroxide, water and acid(s).
 20. With diluent type A, with or without water.
 21. With ≥ 25 per cent diluent type A by mass, and in addition ethylbenzene.
 22. With ≥ 19 per cent diluent type A by mass, and in addition methyl isobutyl ketone.
 23. With < 6 per cent di-tert-butyl peroxide.
 24. With ≤ 8 per cent 1-isopropylhydroperoxy-4-isopropylhydroxybenzene.
 25. Diluent type B with boiling point $> 110^{\circ}\text{C}$.
 26. With < 0.5 per cent hydroperoxides content.
 27. For concentrations more than 56 per cent, "CORROSIVE" subsidiary risk label required (see Figure 5-22).
 28. Available active oxygen ≤ 7.6 per cent in diluent type A having a 95 per cent boil-off point in the range of $220\text{-}260^{\circ}\text{C}$.
 29. Not subject to the requirements of these Instructions for Division 5.2.
 30. Diluent type B with boiling point $> 130^{\circ}\text{C}$.
 31. Active oxygen ≤ 6.7 per cent.
-

Chapter 6

CLASS 6 — TOXIC AND INFECTIOUS SUBSTANCES

INTRODUCTORY NOTE

Note.— Toxins from plant, animal or bacterial sources which do not contain any infectious substances or toxins that are not contained in substances which are infectious substances should be considered for classification in Division 6.1 and assignment to UN 3172.

6.1 DEFINITIONS

Class 6 is divided into two divisions as follows:

- a) Division 6.1 — Toxic substances.

Substances liable either to cause death or injury or to harm human health if swallowed, if inhaled or by skin contact.

Note.— In these Instructions “poisonous” has the same meaning as “toxic”.

- b) Division 6.2 — Infectious substances.

Substances known to contain, or reasonably expected to contain, pathogens. Pathogens are defined as micro-organisms (including bacteria, viruses, rickettsiae, parasites, fungi) and other agents such as prions, which can cause disease in humans or animals.

6.2 DIVISION 6.1 — TOXIC SUBSTANCES

6.2.1 Definitions

For the purposes of these Instructions:

6.2.1.1 *LD₅₀ (median lethal dose) for acute oral toxicity* is the statistically derived single dose of a substance that can be expected to cause death within 14 days in 50 per cent of young adult albino rats when administered by the oral route. The LD₅₀ value is expressed in terms of mass of test substance per mass of test animal (mg/kg).

6.2.1.2 *LD₅₀ for acute dermal toxicity* is that dose of the substance which, administered by continuous contact for 24 hours with the bare skin of albino rabbits, is most likely to cause death within 14 days in half of the animals tested. The number of animals tested must be sufficient to give a statistically significant result and be in conformity with good pharmacological practices. The result is expressed in mg/kg body mass.

6.2.1.3 *LC₅₀ for acute toxicity on inhalation* is that concentration of vapour, mist or dust which, administered by continuous inhalation for one hour to both male and female young adult albino rats, is most likely to cause death within 14 days in half of the animals tested. A solid substance should be tested if at least 10 per cent (by mass) of its total mass is likely to be dust in a respirable range, e.g. the aerodynamic diameter of that particle-fraction is 10 µm or less. A liquid substance should be tested if a mist is likely to be generated in a leakage of the transport containment. Both for solid and liquid substances more than 90 per cent (by mass) of a specimen prepared for inhalation toxicity should be in the respirable range as defined above. The result is expressed in mg/L of air for dusts and mists or in mL/m³ of air (parts per million) for vapours.

6.2.2 Assignment of packing groups

6.2.2.1 Substances of Division 6.1, including pesticides, are allocated among the three packing groups, according to the degree of their toxic hazards in transport as follows:

- a) Packing Group I — Substances and preparations presenting a very severe toxicity risk;
- b) Packing Group II — Substances and preparations presenting a serious toxicity risk;
- c) Packing Group III — Substances and preparations presenting a relatively low toxicity risk.

6.2.2.2 In making this grouping, account must be taken of human experience in instances of accidental poisoning, and of special properties possessed by any individual substance, such as liquid state, high volatility, any special likelihood of penetration, and special biological effects.

6.2.2.3 In the absence of human experience, the grouping must be based on the available data from animal experiments. Three possible routes of administrations must be examined. These routes are exposure through:

- a) oral ingestion;
- b) dermal contact; and
- c) inhalation of dusts, mists, or vapours.

6.2.2.3.1 Appropriate animal tests for the various routes of exposure are described in 6.2.1. When a substance exhibits a different order of toxicity by two or more of these routes of administration, the highest degree of danger must be assigned.

6.2.2.4 The criteria to be applied for grouping a substance according to the toxicity it exhibits by all three routes of administration are presented in the following paragraphs.

6.2.2.4.1 The grouping criteria for the oral and dermal routes as well as for inhalation of dusts and mists are as shown in Table 2-8.

Note. — Substances meeting the criteria of Class 8 and with an inhalation toxicity of dusts and mists (LC_{50}) leading to Packing Group I are only accepted for an allocation to Division 6.1 if the toxicity through oral ingestion or dermal contact is at least in the range of Packing Group I or II. Otherwise, an allocation to Class 8 is made when appropriate (see 8.2.3).

6.2.2.4.2 The criteria for inhalation toxicity of dusts and mists in 6.2.2.4.1 are based on LC_{50} data relating to 1-hour exposures, and where such information is available, it must be used. However, where only LC_{50} data relating to 4-hour exposures to dusts and mists are available, such figures can be multiplied by four and the product substituted in the above criteria, i.e. $LC_{50}(4\text{ h}) \times 4$ is considered the equivalent of $LC_{50}(1\text{ h})$.

6.2.2.4.3 Liquids having toxic vapours must be assigned to the packing groups shown in Table 2-9, where V is that saturated vapour concentration in the air of the substance in mL/m^3 at 20°C and standard atmospheric pressure.

6.2.2.4.4 In Figure 2-1, the criteria according to 6.2.2.4.3 are expressed in graphical form, as an aid to easy classification. However, because of approximations inherent in the use of graphs, substances on or near packing group borderlines must be checked using numerical criteria.

Table 2-8. Grouping criteria for administration through oral ingestion, dermal contact and inhalation of dusts and mists

Packing group	Oral toxicity LD_{50} (mg/kg)	Dermal toxicity LD_{50} (mg/kg)	Inhalation toxicity by dusts and mists LC_{50} (mg/L)
I	≤ 5.0	≤ 50	≤ 0.2
II	> 5.0 and ≤ 50	> 50 and ≤ 200	> 0.2 and ≤ 2.0
III ^a	> 50 and ≤ 300	> 200 and $\leq 1\ 000$	> 2.0 and ≤ 4.0

a. Tear gas substances must be included in Packing Group II even if their toxicity data correspond to Packing Group III values.

Table 2-9. Criteria for inhalation

Packing Group I	$V \geq 10\ LC_{50}$ and $LC_{50} \leq 1\ 000\ \text{mL/m}^3$
Packing Group II	$V \geq LC_{50}$ and $LC_{50} \leq 3\ 000\ \text{mL/m}^3$ and not meeting the criteria for Packing Group I
Packing Group III	$V \geq 0.2\ LC_{50}$ and $LC_{50} \leq 5\ 000\ \text{mL/m}^3$ and not meeting the criteria for Packing Groups I and II

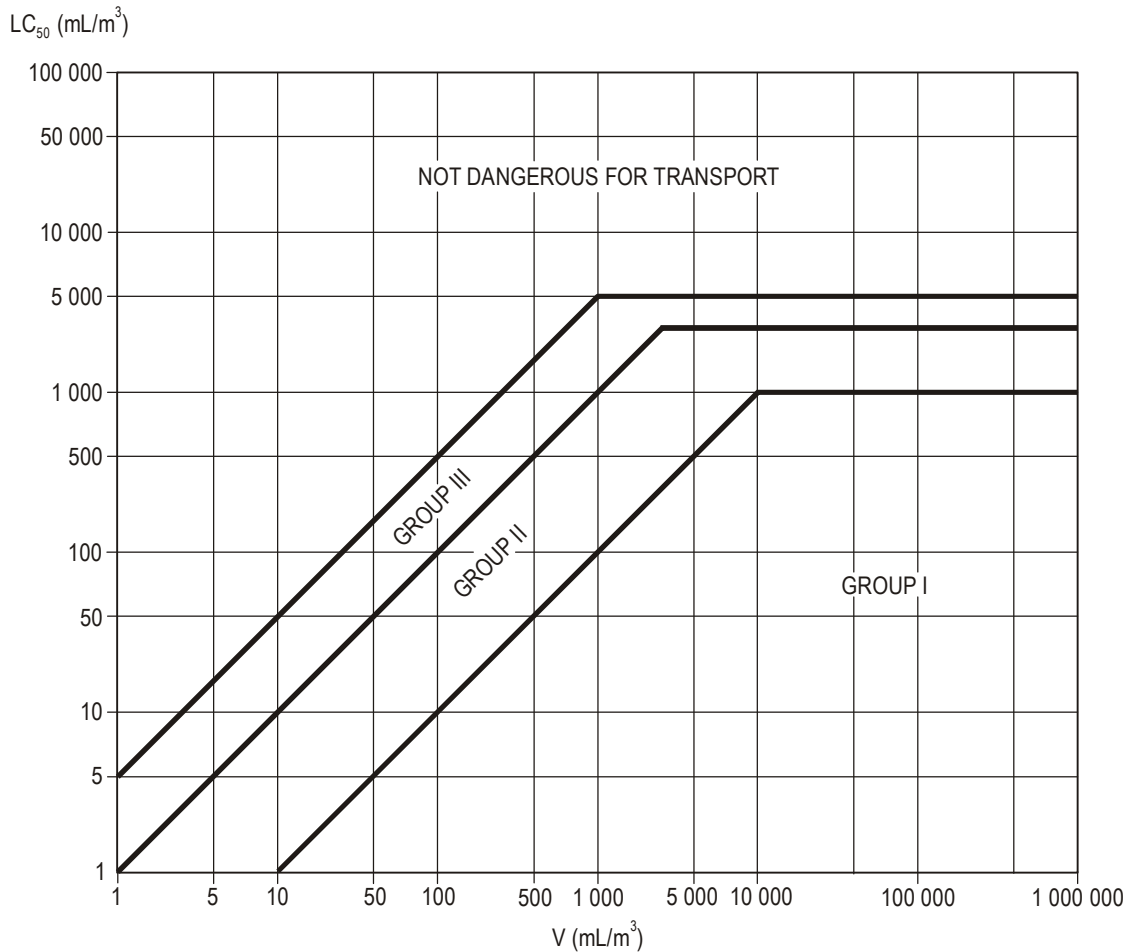

Figure 2-1. Criteria for inhalation of vapours

6.2.2.4.5 The criteria for inhalation toxicity of vapours in 6.2.2.4.3 are based on LC_{50} data relating to 1-hour exposures, and where such information is available, it must be used. However, where only LC_{50} data relating to 4-hour exposures to the vapours are available, such figures can be multiplied by two and the product substituted in the above criteria, i.e. $LC_{50}(4\text{ h}) \times 2$ is considered the equivalent of $LC_{50}(1\text{ h})$.

6.2.2.4.6 Mixtures of liquids that are toxic by inhalation must be assigned to packing groups according to 6.2.2.4.7 or 6.2.2.4.8.

6.2.2.4.7 If LC_{50} data is available for each of the toxic substances comprising a mixture, the packing group may be determined as follows:

- a) Estimate the LC_{50} of the mixture using the formula:

$$LC_{50}(\text{mixture}) = \frac{1}{\sum_{i=1}^n \frac{f_i}{LC_{50i}}}$$

where f_i = mole fraction of the i^{th} component substance of the liquid, and

where LC_{50i} = mean lethal concentration of the i^{th} component substance in mL/m^3

- b) Estimate the volatility of each component substance using the formula:

$$V_i = P_i \times \frac{106}{101.3} \text{ mL/m}^3$$

where P_i = partial pressure of the i^{th} component substance in kPa at 20°C and one atmosphere pressure.

- c) Calculate the ratio of the volatility to the LC_{50} using the formula:

$$R = \sum_{i=1}^n \frac{V_i}{LC_{50_i}}$$

- d) Using the calculated values LC_{50} (mixture) and R, the packing group for the mixture is determined:

Packing Group I: $R \geq 10$ and LC_{50} (mixture) $\leq 1\,000 \text{ mL/m}^3$

Packing Group II: $R \geq 1$ and LC_{50} (mixture) $\leq 3\,000 \text{ mL/m}^3$ and not meeting criteria for Group I

Packing Group III: $R \geq 1/5$ and LC_{50} (mixture) $\leq 5\,000 \text{ mL/m}^3$ and not meeting criteria for Group I or II.

6.2.2.4.8 In the absence of LC_{50} data on the toxic constituent substances, the mixture may be assigned a packing group based on the following simplified threshold toxicity tests. When these threshold tests are used, the most restrictive packing group must be determined and used for transporting the mixture.

- a) A mixture is assigned to Packing Group I only if it meets both of the following criteria:
- A sample of the liquid mixture is vaporized and diluted with air to create a test atmosphere of $1\,000 \text{ mL/m}^3$ vaporized mixture in air. Ten albino rats (5 male and 5 female) are exposed to the test atmosphere for 1 hour and observed for 14 days. If 5 or more of the animals die within the 14-day observation period, the mixture is presumed to have an LC_{50} equal to or less than $1\,000 \text{ mL/m}^3$.
 - A sample of the vapour in equilibrium with the liquid mixture at 20°C is diluted with 9 equal volumes of air to form a test atmosphere. Ten albino rats (5 male and 5 female) are exposed to the test atmosphere for 1 hour and observed for 14 days. If 5 or more of the animals die within the 14-day observation period, the mixture is presumed to have a volatility equal to or greater than 10 times the mixture LC_{50} .
- b) A mixture is assigned to Packing Group II only if it meets both of the following criteria, and the mixture does not meet the criteria for Packing Group I:
- A sample of the liquid mixture is vaporized and diluted with air to create a test atmosphere of $3\,000 \text{ mL/m}^3$ vaporized mixture in air. Ten albino rats (5 male and 5 female) are exposed to the test atmosphere for 1 hour and observed for 14 days. If 5 or more of the animals die within the 14-day observation period, the mixture is presumed to have an LC_{50} equal to or less than $3\,000 \text{ mL/m}^3$.
 - A sample of the vapour in equilibrium with the liquid mixture at 20°C is used to form a test atmosphere. Ten albino rats (5 male and 5 female) are exposed to the test atmosphere for 1 hour and observed for 14 days. If 5 or more of the animals die within the 14-day observation period, the mixture is presumed to have a volatility equal to or greater than the mixture LC_{50} .
- c) A mixture is assigned to Packing Group III only if it meets both of the following criteria, and the mixture does not meet the criteria for Packing Groups I or II:
- A sample of the liquid mixture is vaporized and diluted with air to create a test atmosphere of $5\,000 \text{ mL/m}^3$ vaporized mixture in air. Ten albino rats (5 male and 5 female) are exposed to the test atmosphere for 1 hour and observed for 14 days. If 5 or more of the animals die within the 14-day observation period, the mixture is presumed to have an LC_{50} equal to or less than $5\,000 \text{ mL/m}^3$.
 - The vapour pressure of the liquid mixture is measured and if the vapour pressure is equal to or greater than $1\,000 \text{ mL/m}^3$, the mixture is presumed to have a volatility equal to or greater than 1/5 the mixture LC_{50} .

6.2.3 Methods for determining oral and dermal toxicity of mixtures

6.2.3.1 When classifying and assigning the appropriate packing group to mixtures in Division 6.1, in accordance with the oral and dermal toxicity criteria in Table 2-8, it is necessary to determine the acute LD_{50} of the mixture.

6.2.3.2 If a mixture contains only one active substance, and the LD_{50} of that constituent is known, in the absence of reliable acute oral and dermal toxicity data on the actual mixture to be transported, the oral or dermal LD_{50} may be obtained by the following method:

LD₅₀ value of preparation =

$$\frac{\text{LD}_{50} \text{ value of active substance} \times 100}{\text{percentage of active substance by mass}}$$

6.2.3.3 If a mixture contains more than one active constituent, there are three possible approaches that may be used to determine the oral or dermal LD₅₀ of the mixture. The preferred method is to obtain reliable acute oral and dermal toxicity data on the actual mixture to be transported. If reliable and accurate data are not available, then either of the following methods may be performed:

- a) classify the formulation according to the most hazardous constituent of the mixture as if that constituent were present in the same concentration as the total concentration of all active constituents; or
- b) apply the formula:

$$\frac{C_A}{T_A} + \frac{C_B}{T_B} + \frac{C_Z}{T_Z} = \frac{100}{T_M}$$

where:

- C = the per cent concentration of constituent A, B ... Z in the mixture
- T = the oral LD₅₀ values of constituent A, B ... Z
- T_M = the oral LD₅₀ value of the mixture.

Note.— This formula can also be used for dermal toxicities provided that this information is available on the same species for all constituents. The use of this formula does not take into account any potentiation or protective phenomena.

6.2.4 Classification of pesticides

6.2.4.1 All active pesticide substances and their preparations for which the LC₅₀ and/or LD₅₀ values are known and which are classified in Division 6.1 must be classified under appropriate packing groups in accordance with the criteria given in 6.2.2. Substances and preparations which are characterized by subsidiary risks must be classified according to the precedence of hazards table (Table 2-1) with the assignment of appropriate packing groups.

6.2.4.2 If the oral or dermal LD₅₀ value for a pesticide preparation is not known, but the LD₅₀ value of its active substance(s) is known, the LD₅₀ value for the preparation may be obtained by applying the procedures in 6.2.3.

Note.— LD₅₀ toxicity data for a number of common pesticides may be obtained from the most current edition of the document The WHO Recommended Classification of Pesticides by Hazard and Guidelines to Classification available from the International Programme on Chemical Safety, World Health Organization (WHO), 1211 Geneva 27, Switzerland. While that document may be used as a source of LD₅₀ data for pesticides, its classification system should not be used for purposes of transport classification of, or assignment of packing groups to, pesticides which must be in accordance with these Instructions.

6.2.4.3 The proper shipping name used in the transport of the pesticide must be selected on the basis of the active ingredient, of the physical state of the pesticide and any subsidiary risks it may exhibit.

6.3 DIVISION 6.2 — INFECTIOUS SUBSTANCES

6.3.1 Definitions

For the purposes of these Instructions:

6.3.1.1 *Infectious substances* are substances which are known to contain, or are reasonably expected to contain, pathogens. Pathogens are defined as micro-organisms (including bacteria, viruses, rickettsiae, parasites, fungi) and other agents such as prions, which can cause disease in humans or animals.

6.3.1.2 *Biological products* are those products derived from living organisms which are manufactured and distributed in accordance with the requirements of appropriate national authorities, which may have special licensing requirements, and are used either for prevention, treatment or diagnosis of disease in humans or animals, or for development, experimental or investigational purposes related thereto. They include, but are not limited to, finished or unfinished products such as vaccines.

6.3.1.3 *Cultures* are the result of a process by which pathogens are intentionally propagated. This definition does not include patient specimens as defined in 6.3.1.4.

6.3.1.4 *Patient specimens* are those collected directly from humans or animals, including, but not limited to, excreta, secreta, blood and its components, tissue and tissue fluid swabs, and body parts being transported for purposes such as research, diagnosis, investigational activities, and disease treatment and prevention.

6.3.1.5 *Medical or clinical wastes* are wastes derived from the medical treatment of animals or humans or from bio-research.

6.3.2 Classification of infectious substances

6.3.2.1 Infectious substances must be classified in Division 6.2 and assigned to UN 2814, UN 2900, UN 3291 or UN 3373 as appropriate.

6.3.2.2 Infectious substances are divided into the following categories:

6.3.2.2.1 *Category A*: An infectious substance which is transported in a form that, when exposure to it occurs, is capable of causing permanent disability, life-threatening or fatal disease in otherwise healthy humans or animals. Indicative examples of substances that meet these criteria are given in Table 2-10.

Note. — *An exposure occurs when an infectious substance is released outside of the protective packaging resulting in physical contact with humans or animals.*

- a) Infectious substances meeting these criteria which cause disease in humans or in both humans and animals must be assigned to UN 2814. Infectious substances which cause disease only in animals must be assigned to UN 2900.
- b) Assignments to UN 2814 or UN 2900 must be based on the known medical history and symptoms of the source human or animal, endemic local conditions, or professional judgement concerning individual circumstances of the source human or animal.

Note 1.— *The proper shipping name for UN 2814 is **Infectious substance, affecting humans**. The proper shipping name for UN 2900 is **Infectious substance, affecting animals only**.*

Note 2.— *Table 2-10 is not exhaustive. Infectious substances, including new or emerging pathogens, which do not appear in Table 2-10 but which meet the same criteria must be assigned to Category A. In addition, if there is doubt as to whether or not a substance meets the criteria it must be included in Category A.*

Note 3.— *In Table 2-10, the micro-organisms written in italics are *bacteria*, *mycoplasma*, *rickettsiae* or *fungi*.*

6.3.2.2.2 *Category B*: An infectious substance which does not meet the criteria for inclusion in Category A. Infectious substances in Category B must be assigned to UN 3373.

Note.— *The proper shipping name of UN 3373 is **Biological substances, Category B**.*

6.3.2.3 Exceptions

6.3.2.3.1 Substances which do not contain infectious substances or substances which are unlikely to cause disease in humans or animals are not subject to these Instructions unless they meet the criteria for inclusion in another class.

6.3.2.3.2 Substances containing micro-organisms which are non-pathogenic to humans or animals are not subject to these Instructions unless they meet the criteria for inclusion in another class.

6.3.2.3.3 Substances in a form that any present pathogens have been neutralized or inactivated such that they no longer pose a health risk are not subject to these Instructions unless they meet the criteria for inclusion in another class.

6.3.2.3.4 Environmental samples (including food and water samples) which are not considered to pose a significant risk of infection are not subject to these Instructions unless they meet the criteria for inclusion in another class.

Table 2-10. Indicative examples of infectious substances included in Category A
in any form unless otherwise indicated
(6.3.2.2.1 a))

UN Number and Proper Shipping Name	Micro-organism
<p>UN 2814 Infectious substances affecting humans</p>	<p><i>Bacillus anthracis</i> (cultures only) <i>Brucella abortus</i> (cultures only) <i>Brucella melitensis</i> (cultures only) <i>Brucella suis</i> (cultures only) <i>Burkholderia mallei</i> – <i>Pseudomonas mallei</i> – Glanders (cultures only) <i>Burkholderia pseudomallei</i> – <i>Pseudomonas pseudomallei</i> (cultures only) <i>Chlamydia psittaci</i> – avian strains (cultures only) <i>Clostridium botulinum</i> (cultures only) <i>Coccidioides immitis</i> (cultures only) <i>Coxiella burnetii</i> (cultures only) Crimean-Congo hemorrhagic fever virus Dengue virus (cultures only) Eastern equine encephalitis virus (cultures only) <i>Escherichia coli</i>, verotoxigenic (cultures only) Ebola virus Flexal virus <i>Francisella tularensis</i> (cultures only) Guanarito virus Hantaan virus Hantaviruses causing haemorrhagic fever with renal syndrome Hendra virus Hepatitis B virus (cultures only) Herpes B virus (cultures only) Highly pathogenic avian influenza virus (cultures only) Human immunodeficiency virus (cultures only) Japanese Encephalitis virus (cultures only) Junin virus Kysanur Forest disease virus Lassa virus Machupo virus Marburg virus Monkeypox virus <i>Mycobacterium tuberculosis</i> (cultures only) Nipah virus Omsk hemorrhagic fever virus Poliovirus (cultures only) Rabies virus (cultures only) <i>Rickettsia prowazekii</i> (cultures only) <i>Rickettsia rickettsii</i> (cultures only) Rift Valley fever virus (cultures only) Russian spring-summer encephalitis virus (cultures only) Sabia virus <i>Shigella dysenteriae</i> type 1 (cultures only) Tick-borne encephalitis virus (cultures only) Variola virus Venezuelan equine encephalitis virus (cultures only) West Nile virus (cultures only) Yellow fever virus (cultures only) <i>Yersinia pestis</i> (cultures only)</p>
<p>UN 2900 Infectious substances affecting animals only</p>	<p>African swine fever virus (cultures only) Avian paramyxovirus Type 1 – Velogenic Newcastle disease virus (cultures only) Classical swine fever virus (cultures only) Foot and mouth disease virus (cultures only) Goatpox virus (cultures only) Lumpy skin disease virus (cultures only) <i>Mycoplasma mycoides</i> – Contagious bovine pleuropneumonia (cultures only) Peste des petits ruminants virus (cultures only) Rinderpest virus (cultures only) Sheep-pox virus (cultures only) Swine vesicular disease virus (cultures only) Vesicular stomatitis virus (cultures only)</p>

- ≠ 6.3.2.3.5 Dried blood spots, collected by applying a drop of blood onto absorbent material, are not subject to these Instructions.
- ≠ 6.3.2.3.6 Faecal occult blood screening samples are not are not subject to these Instructions.
- ≠ 6.3.2.3.7 Blood or blood components that have been collected for the purposes of transfusion or for the preparation of blood products to be used for transfusion or transplantation and any tissues or organs intended for use in transplantation as well as samples drawn in connection with such purposes are not subject to these Instructions.
- ≠ 6.3.2.3.8 Patient specimens for which there is minimal likelihood that pathogens are present are not subject to other provisions of these Instructions provided the following conditions are met:
- + a) The specimen must be transported in a packaging which will prevent any leakage and which must be marked with the words "Exempt human specimen" or "Exempt animal specimen", as appropriate;
- ≠ b) The packaging must consist of three components:
- i) a leakproof primary receptacle(s);
 - ii) a leakproof secondary packaging; and
 - iii) an outer packaging of adequate strength for its capacity, mass and intended use, and with at least one surface having minimum dimensions of 100 mm × 100 mm;
- ≠ c) For liquids, absorbent material in sufficient quantity to absorb the entire contents must be placed between the primary receptacle(s) and the secondary packaging so that, during transport, any release or leak of a liquid substance will not reach the outer packaging and will not compromise the integrity of the cushioning material;
- ≠ d) When multiple fragile primary receptacles are placed in a single secondary packaging, they must be either individually wrapped or separated to prevent contact between them.
- + e) If refrigerated or frozen specimens are to be transported, the following conditions must be met:
- i) when dry ice or liquid nitrogen is used to keep specimens cold, all applicable requirements of these Instructions must be met. When used, ice or dry ice must be placed outside the secondary packaging or in the outer packaging. Interior supports must be provided to secure the secondary packaging in the original position after the ice or dry ice has dissipated. If ice is used, the outside packaging must be leakproof. If carbon dioxide, solid (dry ice) is used, the packaging must be designed and constructed to permit the release of carbon dioxide gas to prevent a build-up of pressure that could rupture the packagings;
 - ii) the primary receptacle and the secondary packaging must maintain their integrity at the temperature of the refrigerant used as well as the temperatures and the pressures which could result if refrigeration were lost.
- Note.— In determining whether a patient specimen has a minimum likelihood that pathogens are present, an element of professional judgement is required to determine if a substance is exempt under this paragraph. That judgement should be based on the known medical history, symptoms and individual circumstances of the source, human or animal, and endemic local conditions. Examples of specimens which may be transported under this paragraph include blood or urine tests to monitor cholesterol levels, blood glucose levels, hormone levels, or prostate specific antibodies (PSA); tests required to monitor organ function such as heart, liver or kidney function for humans or animals with non-infectious diseases, or therapeutic drug monitoring; tests conducted for insurance or employment purposes and are intended to determine the presence of drugs or alcohol; pregnancy tests; biopsies to detect cancer; and antibody detection in humans or animals in the absence of any concern for infection (e.g. evaluation of vaccine induced immunity, diagnosis of autoimmune disease, etc.).*
- ≠ 6.3.2.3.9 Except for:
- a) medical waste (UN 3291);
 - b) medical devices or equipment contaminated with or containing infectious substances in Category A (UN 2814 or UN 2900); and
 - c) medical devices or equipment contaminated with or containing other dangerous goods that meet the definition of another hazard class,

medical devices or equipment potentially contaminated with or containing infectious substances which are being transported for disinfection, cleaning, sterilization, repair, or equipment evaluation are not subject to the provisions of these Instructions if packed in packagings designed and constructed in such a way that, under normal conditions of transport, they cannot break, be punctured or leak their contents. Packagings must be designed to meet the construction requirements listed in 6;3.

- ≠ 6.3.2.3.9.1 Medical devices or equipment must be drained of free liquid to the extent practicable. They must be packed in a strong rigid outer packaging fitted with sufficient cushioning material to prevent movement within the outer packaging. These packagings must meet the general packing requirements of 4;1.1.1, 4;1.1.3.1 and 4;1.1.4 (with the exception of 4;1.1.4.1). If the outer packaging is not liquid tight and the medical devices or equipment are contaminated with or contain liquid infectious substances, a means of containing the liquid in the event of leakage must be provided in the form of a leakproof liner, plastic bag or other equally effective means of containment. These packagings must be capable of retaining the medical devices and equipment when dropped from a height of 1.2 m.
- + *Note.— A packaging's capability of retaining medical devices or equipment when dropped from a height of 1.2 m should be determined through testing a sample package as prepared for transport or through alternative means such as non-destructive testing and engineering analysis, testing with an article of similar mass and size, or other equivalent means.*
- ≠ 6.3.2.3.9.2 Packages must be marked "Used medical device" or "Used medical equipment". When an overpack is used, it must be marked with the words "Used medical device" or "Used medical equipment" unless the markings are visible.

6.3.3 Biological products

For the purposes of these Instructions, biological products are divided into the following groups:

- a) Those which are manufactured and packaged in accordance with the requirements of appropriate national authorities and transported for the purposes of final packaging or distribution, and use for personal health care by medical professionals or individuals. Substances in this group are not subject to these Instructions.
- b) Those which do not fall under paragraph a) and are known or reasonably believed to contain infectious substances and which meet the criteria for inclusion in Category A or Category B. Substances in this group must be assigned to UN 2814, UN 2900 or UN 3373, as appropriate.

Note.— Some licensed biological products may present a biohazard only in certain parts of the world. In that case, appropriate national authorities may require these biological products to be in compliance with local requirements for infectious substances or may impose other restrictions.

6.3.4 Genetically modified micro-organisms and organisms

Genetically modified micro-organisms not meeting the definition of infectious substances must be classified according to Chapter 9.

6.3.5 Medical or clinical wastes

6.3.5.1 Medical or clinical wastes containing Category A infectious substances must be assigned to UN 2814 or UN 2900 as appropriate. Medical or clinical wastes containing infectious substances in Category B must be assigned to UN 3291.

6.3.5.2 Medical or clinical wastes that are reasonably believed to have a low probability of containing infectious substances must be assigned to UN 3291. For the assignment, international, regional or national waste catalogues may be taken into account.

*Note.— The proper shipping name for UN 3291 is **Clinical waste, unspecified, n.o.s.** or **Biomedical waste, n.o.s.** or **Medical waste, n.o.s.** or **Regulated medical waste, n.o.s.***

6.3.5.3 Decontaminated medical or clinical wastes that previously contained infectious substances are not subject to these Instructions unless they meet the criteria for inclusion in another class.

6.3.6 Infected live animals

6.3.6.1 A live animal that has been intentionally infected and is known or suspected to contain an infectious substance must not be transported by air unless the infectious substance contained cannot be consigned by any other means. Infected live animals may only be transported under the terms and conditions of an approval granted by the appropriate national authority.

6.3.6.2 Unless an infectious substance cannot be consigned by any other means, live animals must not be used to consign such a substance.

6.3.6.3 Animal material affected by pathogens of Category A or which would be assigned to Category A in cultures only, must be assigned to UN 2814 or UN 2900 as appropriate.

6.3.7 Patient specimens

Patient specimens must be assigned to UN 2814, UN 2900 or UN 3373 as appropriate except if they comply with 6.3.2.3.

Chapter 7

CLASS 7 — RADIOACTIVE MATERIAL

Parts of this Chapter are affected by State Variations BE 4, CA 1, CA 3, CA 4, CH 4, DE 3, DK 1, DQ 1, IR 4, JP 26, KG 1, NL 3; see Table A-1

Note.— For Class 7, the type of packaging may have a decisive effect on classification.

7.1 DEFINITIONS

7.1.1 *Radioactive material.* Any material containing radionuclides where both the activity concentration and the total activity in the consignment exceed the values specified in 7.2.2.1 to 7.2.2.6.

7.1.2 Contamination

Contamination. The presence of a radioactive substance on a surface in quantities in excess of 0.4 Bq/cm² for beta and gamma emitters and low toxicity alpha emitters, or 0.04 Bq/cm² for all other alpha emitters.

Non-fixed contamination. Contamination that can be removed from a surface during routine conditions of transport.

Fixed contamination. Contamination other than non-fixed contamination.

7.1.3 Definitions of specific terms

A_1 and A_2 :

A_1 . The activity value of special form radioactive material, which is listed in Table 2-12 or derived in 7.2.2.2 and is used to determine the activity limits for the requirements of these Instructions.

A_2 . The activity value of radioactive material, other than special form radioactive material, which is listed in Table 2-12 or derived in 7.2.2.2 and is used to determine the activity limits for the requirements of these Instructions.

≠ *Fissile nuclides.* Uranium-233, uranium-235, plutonium-239 and plutonium-241. Fissile material is a material containing any of the fissile nuclides. Excluded from the definition of fissile material are the following:

≠ a) natural uranium or depleted uranium which is unirradiated;

≠ b) natural uranium or depleted uranium which has been irradiated in thermal reactors only;

+ c) material with fissile nuclides less than a total of 0.25 g;

+ d) any combination of a), b) and/or c).

+ These exclusions are only valid if there is no other material with fissile nuclides in the package.

≠ *Freight container in the case of radioactive material transport.* An article of transport equipment designed to facilitate the transport of packaged goods by one or more modes of transport without intermediate reloading, which is of a permanent enclosed character, rigid and strong enough for repeated use, and must be fitted with devices facilitating its handling, particularly in transfer between aircraft and from one mode of transport to another. In addition, a small freight container is that which has an internal volume of not more than 3 m³. A large freight container is that which has an internal volume of more than 3 m³. For the transport of radioactive material, a freight container may be used as a packaging.

Low dispersible radioactive material. A solid radioactive material or a solid radioactive material in a sealed capsule, that has limited dispersibility and is not in powder form.

Low specific activity (LSA) material. Radioactive material which by its nature has a limited specific activity, or radioactive material for which limits of estimated average specific activity apply. External shielding materials surrounding the LSA material must not be considered in determining the estimated average specific activity.

Low toxicity alpha emitters. Natural uranium; depleted uranium; natural thorium; uranium-235 or uranium-238; thorium-232; thorium-228 and thorium-230 when contained in ores or physical and chemical concentrates; or alpha emitters with a half-life of less than 10 days.

Packaging in the case of radioactive material. The assembly of components necessary to enclose the radioactive contents completely. It may, in particular, consist of one or more receptacles, absorbent materials, spacing structures, radiation shielding and service equipment for filling, emptying, venting and pressure relief; devices for cooling, absorbing mechanical shocks, handling and tie-down, thermal insulation; and service devices integral to the package. The packaging may be a box, drum or similar receptacle, or may also be a freight container.

Note.— For packagings for other dangerous goods, see definitions under 1;3.1.1.

Special form radioactive material. Either:

- a) an indispersible solid radioactive material; or
- b) a sealed capsule containing radioactive material.

Specific activity of a radionuclide. The activity per unit mass of that nuclide. The specific activity of a material must mean the activity per unit mass of the material in which the radionuclides are essentially uniformly distributed.

≠ *Surface contaminated object (SCO).* A solid object which is not itself radioactive but which has radioactive material distributed on its surface.

Transport index (TI) assigned to a package, overpack or freight container, or to unpackaged LSA-I or SCO-I. A number which is used to provide control over radiation exposure.

Unirradiated thorium. Thorium containing not more than 10^{-7} g of uranium-233 per gram of thorium-232.

Unirradiated uranium. Uranium containing not more than 2×10^3 Bq of plutonium per gram of uranium-235, not more than 9×10^6 Bq of fission products per gram of uranium-235 and not more than 5×10^{-3} g of uranium-236 per gram of uranium-235.

Uranium — natural, depleted, enriched:

Natural uranium. Uranium (which may be chemically separated) containing the naturally occurring distribution of uranium isotopes (approximately 99.28 per cent uranium-238, and 0.72 per cent uranium-235 by mass).

Depleted uranium. Uranium containing a lesser mass percentage of uranium-235 than in natural uranium.

Enriched uranium. Uranium containing a greater mass percentage of uranium-235 than 0.72 per cent. In all cases, a very small mass percentage of uranium-234 is present.

7.2 CLASSIFICATION

7.2.1 General provisions

≠ 7.2.1.1 Radioactive material must be assigned to one of the UN numbers specified in Table 2-11 in accordance with 7.2.4.2 to 7.2.4.5, taking into account the material characteristics determined in 7.2.3.

Table 2-11. Assignment of UN numbers

≠	UN number	Proper shipping name and description ^a
	<i>Excepted packages (1;6.1.5)</i>	
	UN 2908	Radioactive material, excepted package — empty packaging
	UN 2909	Radioactive material, excepted package — articles manufactured from natural uranium or depleted uranium or natural thorium
	UN 2910	Radioactive material, excepted package — limited quantity of material
	UN 2911	Radioactive material, excepted package — instruments or articles
+	UN 3507	Uranium hexafluoride, radioactive material, excepted package, less than 0.1 kg per package, non-fissile or fissile-excepted^{b,c}
	<i>Low specific activity radioactive material (7.2.3.1)</i>	
≠	UN 2912	Radioactive material, low specific activity (LSA-I), non-fissile or fissile excepted^d
≠	UN 3321	Radioactive material, low specific activity (LSA-II), non-fissile or fissile excepted^d
≠	UN 3322	Radioactive material, low specific activity (LSA-III), non-fissile or fissile excepted^d

≠	UN number	Proper shipping name and description ^a
	UN 3324	Radioactive material, low specific activity (LSA-II) fissile
	UN 3325	Radioactive material, low specific activity (LSA-III) fissile
<i>Surface contaminated objects (7.2.3.2)</i>		
≠	UN 2913	Radioactive material, surface contaminated objects (SCO-I or SCO-II), non-fissile or fissile excepted^b
	UN 3326	Radioactive material, surface contaminated objects (SCO-I or SCO-II), fissile
<i>Type A packages (7.2.4.4)</i>		
≠	UN 2915	Radioactive material, Type A package, non-special form, non-fissile or fissile excepted^d
	UN 3327	Radioactive material, Type A package, fissile, non-special form
≠	UN 3332	Radioactive material, Type A package, special form, non-fissile or fissile excepted^d
	UN 3333	Radioactive material, Type A package, special form, fissile
<i>Type B(U) package (7.2.4.6)</i>		
≠	UN 2916	Radioactive material, Type B(U) package, non-fissile or fissile excepted^d
	UN 3328	Radioactive material, Type B(U) package, fissile
<i>Type B(M) package (7.2.4.6)</i>		
≠	UN 2917	Radioactive material, Type B(M) package, non-fissile or fissile excepted^d
	UN 3329	Radioactive material, Type B(M) package, fissile
<i>Type C package (7.2.4.6)</i>		
≠	UN 3323	Radioactive material, Type C package, non-fissile or fissile excepted^d
	UN 3330	Radioactive material, Type C package, fissile
<i>Special arrangement (7.2.5)</i>		
≠	UN 2919	Radioactive material, transported under special arrangement, non-fissile or fissile excepted^d
	UN 3331	Radioactive material, transported under special arrangement, fissile
<i>Uranium hexafluoride (7.2.4.5)</i>		
	UN 2977	Radioactive material, uranium hexafluoride, fissile
≠	UN 2978	Radioactive material, uranium hexafluoride, non-fissile or fissile excepted^d
+	UN 3507	Uranium hexafluoride, radioactive material, excepted package, less than 0.1 kg per package, non-fissile or fissile-excepted^{b,c}
+	a. The proper shipping name is found in the column "proper shipping name and description" and is restricted to that part shown in bold letters. In the cases of UN Nos. 2909, 2911, 2913 and 3326, where alternative proper shipping names are separated by the word "or", only the relevant proper shipping name must be used.	
+	b. The term "fissile-excepted" refers only to material excepted under 7.2.3.5.	
+	c. For UN No. 3507, see also Special Provision A194.	

≠ **7.2.2 Determination of basic radionuclide values**

7.2.2.1 The following basic values for individual radionuclides are given in Table 2-12:

- a) A_1 and A_2 in TBq;
- ≠ b) activity concentration limits for exempt material in Bq/g; and
- c) activity limits for exempt consignments in Bq.

7.2.2.2 For individual radionuclides:

- ≠ a) which are not listed in Table 2-12, determination of the basic radionuclide values referred to in 7.2.2.1 requires multilateral approval. For these radionuclides, activity concentration limits for exempt material and activity limits for exempt consignments must be calculated in accordance with the principles established in the *International Basic Safety Standards for Protection against Ionizing Radiation and for the Safety of Radiation Sources*, Safety Series No.115, IAEA, Vienna (1996). It is permissible to use the A_2 value calculated using a dose coefficient for the appropriate lung absorption type as recommended by the International Commission on Radiological Protection, if the chemical forms of each radionuclide under both normal and accident conditions of transport are taken into consideration. Alternatively, the radionuclide values in Table 2-13 may be used without obtaining competent authority approval.
- + b) in instruments or articles in which the radioactive material is enclosed or is included as a component part of the instrument or other manufactured article and which meet 7.2.4.1.1.3 c), alternative basic radionuclide values to those in Table 2-12 for the activity limit for an exempt consignment are permitted and require multilateral approval. Such alternative activity limits for an exempt consignment must be calculated in accordance with the principles set out in the *International Basic Safety Standards for Protection against Ionizing Radiation and for the Safety of Radiation Sources*, Safety Series No.115, IAEA, Vienna (1996).

7.2.2.3 In the calculations of A_1 and A_2 for a radionuclide not in Table 2-12, a single radioactive decay chain in which the radionuclides are present in their naturally occurring proportions, and in which no daughter nuclide has a half-life either longer than 10 days or longer than that of the parent nuclide, must be considered as a single radionuclide; and the activity to be taken into account and the A_1 or A_2 value to be applied must be that corresponding to the parent nuclide of that chain. In the case of radioactive decay chains in which any daughter nuclide has a half-life either longer than 10 days or greater than that of the parent nuclide, the parent and such daughter nuclides must be considered as mixtures of different nuclides.

- ≠ 7.2.2.4 For mixtures of radionuclides, the basic radionuclide values referred to in 7.2.2.1 may be determined as follows:

$$X_m = \frac{1}{\sum_i \frac{f(i)}{X(i)}}$$

where,

$f(i)$ is the fraction of activity or activity concentration of radionuclide i in the mixture;

- ≠ $X(i)$ is the appropriate value of A_1 or A_2 or the activity concentration limit for exempt material or the activity limit for an exempt consignment as appropriate for the radionuclide i ; and
- ≠ X_m is the derived value of A_1 or A_2 or the activity concentration limit for exempt material or the activity limit for an exempt consignment in the case of a mixture.

7.2.2.5 When the identity of each radionuclide is known but the individual activities of some of the radionuclides are not known, the radionuclides may be grouped and the lowest radionuclide value, as appropriate, for the radionuclides in each group may be used in applying the formulas in 7.2.2.4 and 7.2.4.4. Groups may be based on the total alpha activity and the total beta/gamma activity when these are known, using the lowest radionuclide values for the alpha emitters or beta/gamma emitters, respectively.

7.2.2.6 For individual radionuclides or for mixtures of radionuclides for which relevant data are not available, the values shown in Table 2-13 must be used.

Table 2-12. Basic radionuclides values for individual radionuclides

Radionuclide (atomic number)	Special form A_1 (TBq)	Other form A_2 (TBq)	Activity concentration limit for exempt material (Bq/g)	Activity limit for an exempt consignment (Bq)
Actinium (89)				
Ac-225 (a)	8×10^{-1}	6×10^{-3}	1×10^1	1×10^4
Ac-227 (a)	9×10^{-1}	9×10^{-5}	1×10^{-1}	1×10^3
Ac-228	6×10^{-1}	5×10^{-1}	1×10^1	1×10^6
Silver (47)				
Ag-105	2×10^0	2×10^0	1×10^2	1×10^6
Ag-108m (a)	7×10^{-1}	7×10^{-1}	1×10^1 (b)	1×10^6 (b)
Ag-110m (a)	4×10^{-1}	4×10^{-1}	1×10^1	1×10^6
Ag-111	2×10^0	6×10^{-1}	1×10^3	1×10^6
Aluminium (13)				
Al-26	1×10^{-1}	1×10^{-1}	1×10^1	1×10^5
Americium (95)				
Am-241	1×10^1	1×10^{-3}	1×10^0	1×10^4
Am-242m (a)	1×10^1	1×10^{-3}	1×10^0 (b)	1×10^4 (b)
Am-243 (a)	5×10^0	1×10^{-3}	1×10^0 (b)	1×10^3 (b)
Argon (18)				
Ar-37	4×10^1	4×10^1	1×10^6	1×10^8
Ar-39	4×10^1	2×10^1	1×10^7	1×10^4
Ar-41	3×10^{-1}	3×10^{-1}	1×10^2	1×10^9
Arsenic (33)				
As-72	3×10^{-1}	3×10^{-1}	1×10^1	1×10^5
As-73	4×10^1	4×10^1	1×10^3	1×10^7
As-74	1×10^0	9×10^{-1}	1×10^1	1×10^6
As-76	3×10^{-1}	3×10^{-1}	1×10^2	1×10^5
As-77	2×10^1	7×10^{-1}	1×10^3	1×10^6
Astatine (85)				
At-211 (a)	2×10^1	5×10^{-1}	1×10^3	1×10^7
Gold (79)				
Au-193	7×10^0	2×10^0	1×10^2	1×10^7
Au-194	1×10^0	1×10^0	1×10^1	1×10^6
Au-195	1×10^1	6×10^0	1×10^2	1×10^7
Au-198	1×10^0	6×10^{-1}	1×10^2	1×10^6
Au-199	1×10^1	6×10^{-1}	1×10^2	1×10^6
Barium (56)				
Ba-131 (a)	2×10^0	2×10^0	1×10^2	1×10^6
Ba-133	3×10^0	3×10^0	1×10^2	1×10^6

<i>Radionuclide (atomic number)</i>	<i>Special form A₁ (TBq)</i>	<i>Other form A₂ (TBq)</i>	<i>Activity concentration limit for exempt material (Bq/g)</i>	<i>Activity limit for an exempt consignment (Bq)</i>
Ba-133m	2×10^1	6×10^{-1}	1×10^2	1×10^6
Ba-140 (a)	5×10^{-1}	3×10^{-1}	1×10^1 (b)	1×10^5 (b)
Beryllium (4)				
Be-7	2×10^1	2×10^1	1×10^3	1×10^7
Be-10	4×10^1	6×10^{-1}	1×10^4	1×10^6
Bismuth (83)				
Bi-205	7×10^{-1}	7×10^{-1}	1×10^1	1×10^6
Bi-206	3×10^{-1}	3×10^{-1}	1×10^1	1×10^5
Bi-207	7×10^{-1}	7×10^{-1}	1×10^1	1×10^6
Bi-210	1×10^0	6×10^{-1}	1×10^3	1×10^6
Bi-210m(a)	6×10^{-1}	2×10^{-2}	1×10^1	1×10^5
Bi-212 (a)	7×10^{-1}	6×10^{-1}	1×10^1 (b)	1×10^5 (b)
Berkelium (97)				
Bk-247	8×10^0	8×10^{-4}	1×10^0	1×10^4
Bk-249 (a)	4×10^1	3×10^{-1}	1×10^3	1×10^6
Bromine (35)				
Br-76	4×10^{-1}	4×10^{-1}	1×10^1	1×10^5
Br-77	3×10^0	3×10^0	1×10^2	1×10^6
Br-82	4×10^{-1}	4×10^{-1}	1×10^1	1×10^6
Carbon (6)				
C-11	1×10^0	6×10^{-1}	1×10^1	1×10^6
C-14	4×10^1	3×10^0	1×10^4	1×10^7
Calcium (20)				
Ca-41	Unlimited	Unlimited	1×10^5	1×10^7
Ca-45	4×10^1	1×10^0	1×10^4	1×10^7
Ca-47 (a)	3×10^0	3×10^{-1}	1×10^1	1×10^6
Cadmium (48)				
Cd-109	3×10^1	2×10^0	1×10^4	1×10^6
Cd-113m	4×10^1	5×10^{-1}	1×10^3	1×10^6
Cd-115 (a)	3×10^0	4×10^{-1}	1×10^2	1×10^6
Cd-115m	5×10^{-1}	5×10^{-1}	1×10^3	1×10^6
Cerium (58)				
Ce-139	7×10^0	2×10^0	1×10^2	1×10^6
Ce-141	2×10^1	6×10^{-1}	1×10^2	1×10^7
Ce-143	9×10^{-1}	6×10^{-1}	1×10^2	1×10^6
Ce-144 (a)	2×10^{-1}	2×10^{-1}	1×10^2 (b)	1×10^5 (b)
Californium (98)				

<i>Radionuclide (atomic number)</i>	<i>Special form A₁ (TBq)</i>	<i>Other form A₂ (TBq)</i>	<i>Activity concentration limit for exempt material (Bq/g)</i>	<i>Activity limit for an exempt consignment (Bq)</i>
Cf-248	4×10^1	6×10^{-3}	1×10^1	1×10^4
Cf-249	3×10^0	8×10^{-4}	1×10^0	1×10^3
Cf-250	2×10^1	2×10^{-3}	1×10^1	1×10^4
Cf-251	7×10^0	7×10^{-4}	1×10^0	1×10^3
Cf-252	1×10^{-1}	3×10^{-3}	1×10^1	1×10^4
Cf-253 (a)	4×10^1	4×10^{-2}	1×10^2	1×10^5
Cf-254	1×10^{-3}	1×10^{-3}	1×10^0	1×10^3
Chlorine (17)				
Cl-36	1×10^1	6×10^{-1}	1×10^4	1×10^6
Cl-38	2×10^{-1}	2×10^{-1}	1×10^1	1×10^5
Curium (96)				
Cm-240	4×10^1	2×10^{-2}	1×10^2	1×10^5
Cm-241	2×10^0	1×10^0	1×10^2	1×10^6
Cm-242	4×10^1	1×10^{-2}	1×10^2	1×10^5
Cm-243	9×10^0	1×10^{-3}	1×10^0	1×10^4
Cm-244	2×10^1	2×10^{-3}	1×10^1	1×10^4
Cm-245	9×10^0	9×10^{-4}	1×10^0	1×10^3
Cm-246	9×10^0	9×10^{-4}	1×10^0	1×10^3
Cm-247 (a)	3×10^0	1×10^{-3}	1×10^0	1×10^4
Cm-248	2×10^{-2}	3×10^{-4}	1×10^0	1×10^3
Cobalt (27)				
Co-55	5×10^{-1}	5×10^{-1}	1×10^1	1×10^6
Co-56	3×10^{-1}	3×10^{-1}	1×10^1	1×10^5
Co-57	1×10^1	1×10^1	1×10^2	1×10^6
Co-58	1×10^0	1×10^0	1×10^1	1×10^6
Co-58m	4×10^1	4×10^1	1×10^4	1×10^7
Co-60	4×10^{-1}	4×10^{-1}	1×10^1	1×10^5
Chromium (24)				
Cr-51	3×10^1	3×10^1	1×10^3	1×10^7
Caesium (55)				
Cs-129	4×10^0	4×10^0	1×10^2	1×10^5
Cs-131	3×10^1	3×10^1	1×10^3	1×10^6
Cs-132	1×10^0	1×10^0	1×10^1	1×10^5
Cs-134	7×10^{-1}	7×10^{-1}	1×10^1	1×10^4
Cs-134m	4×10^1	6×10^{-1}	1×10^3	1×10^5
Cs-135	4×10^1	1×10^0	1×10^4	1×10^7
Cs-136	5×10^{-1}	5×10^{-1}	1×10^1	1×10^5

<i>Radionuclide (atomic number)</i>	<i>Special form A₁ (TBq)</i>	<i>Other form A₂ (TBq)</i>	<i>Activity concentration limit for exempt material (Bq/g)</i>	<i>Activity limit for an exempt consignment (Bq)</i>
Cs-137 (a)	2×10^0	6×10^{-1}	1×10^1 (b)	1×10^4 (b)
Copper (29)				
Cu-64	6×10^0	1×10^0	1×10^2	1×10^6
Cu-67	1×10^1	7×10^{-1}	1×10^2	1×10^6
Dysprosium (66)				
Dy-159	2×10^1	2×10^1	1×10^3	1×10^7
Dy-165	9×10^{-1}	6×10^{-1}	1×10^3	1×10^6
Dy-166 (a)	9×10^{-1}	3×10^{-1}	1×10^3	1×10^6
Erbium (68)				
Er-169	4×10^1	1×10^0	1×10^4	1×10^7
Er-171	8×10^{-1}	5×10^{-1}	1×10^2	1×10^6
Europium (63)				
Eu-147	2×10^0	2×10^0	1×10^2	1×10^6
Eu-148	5×10^{-1}	5×10^{-1}	1×10^1	1×10^6
Eu-149	2×10^1	2×10^1	1×10^2	1×10^7
Eu-150 (short-lived)	2×10^0	7×10^{-1}	1×10^3	1×10^6
Eu-150 (long-lived)	7×10^{-1}	7×10^{-1}	1×10^1	1×10^6
Eu-152	1×10^0	1×10^0	1×10^1	1×10^6
Eu-152m	8×10^{-1}	8×10^{-1}	1×10^2	1×10^6
Eu-154	9×10^{-1}	6×10^{-1}	1×10^1	1×10^6
Eu-155	2×10^1	3×10^0	1×10^2	1×10^7
Eu-156	7×10^{-1}	7×10^{-1}	1×10^1	1×10^6
Fluorine (9)				
F-18	1×10^0	6×10^{-1}	1×10^1	1×10^6
Iron (26)				
Fe-52 (a)	3×10^{-1}	3×10^{-1}	1×10^1	1×10^6
Fe-55	4×10^1	4×10^1	1×10^4	1×10^6
Fe-59	9×10^{-1}	9×10^{-1}	1×10^1	1×10^6
Fe-60 (a)	4×10^1	2×10^{-1}	1×10^2	1×10^5
Gallium (31)				
Ga-67	7×10^0	3×10^0	1×10^2	1×10^6
Ga-68	5×10^{-1}	5×10^{-1}	1×10^1	1×10^5
Ga-72	4×10^{-1}	4×10^{-1}	1×10^1	1×10^5
Gadolinium (64)				
Gd-146 (a)	5×10^{-1}	5×10^{-1}	1×10^1	1×10^6
Gd-148	2×10^1	2×10^{-3}	1×10^1	1×10^4
Gd-153	1×10^1	9×10^0	1×10^2	1×10^7

<i>Radionuclide (atomic number)</i>	<i>Special form A₁ (TBq)</i>	<i>Other form A₂ (TBq)</i>	<i>Activity concentration limit for exempt material (Bq/g)</i>	<i>Activity limit for an exempt consignment (Bq)</i>
Gd-159	3×10^0	6×10^{-1}	1×10^3	1×10^6
Germanium (32)				
Ge-68 (a)	5×10^{-1}	5×10^{-1}	1×10^1	1×10^5
Ge-71	4×10^1	4×10^1	1×10^4	1×10^8
Ge-77	3×10^{-1}	3×10^{-1}	1×10^1	1×10^5
Hafnium (72)				
Hf-172 (a)	6×10^{-1}	6×10^{-1}	1×10^1	1×10^6
Hf-175	3×10^0	3×10^0	1×10^2	1×10^6
Hf-181	2×10^0	5×10^{-1}	1×10^1	1×10^6
Hf-182	Unlimited	Unlimited	1×10^2	1×10^6
Mercury (80)				
Hg-194 (a)	1×10^0	1×10^0	1×10^1	1×10^6
Hg-195m (a)	3×10^0	7×10^{-1}	1×10^2	1×10^6
Hg-197	2×10^1	1×10^1	1×10^2	1×10^7
Hg-197m	1×10^1	4×10^{-1}	1×10^2	1×10^6
Hg-203	5×10^0	1×10^0	1×10^2	1×10^5
Holmium (67)				
Ho-166	4×10^{-1}	4×10^{-1}	1×10^3	1×10^5
Ho-166m	6×10^{-1}	5×10^{-1}	1×10^1	1×10^6
Iodine (53)				
I-123	6×10^0	3×10^0	1×10^2	1×10^7
I-124	1×10^0	1×10^0	1×10^1	1×10^6
I-125	2×10^1	3×10^0	1×10^3	1×10^6
I-126	2×10^0	1×10^0	1×10^2	1×10^6
I-129	Unlimited	Unlimited	1×10^2	1×10^5
I-131	3×10^0	7×10^{-1}	1×10^2	1×10^6
I-132	4×10^{-1}	4×10^{-1}	1×10^1	1×10^5
I-133	7×10^{-1}	6×10^{-1}	1×10^1	1×10^6
I-134	3×10^{-1}	3×10^{-1}	1×10^1	1×10^5
I-135 (a)	6×10^{-1}	6×10^{-1}	1×10^1	1×10^6
Indium (49)				
In-111	3×10^0	3×10^0	1×10^2	1×10^6
In-113m	4×10^0	2×10^0	1×10^2	1×10^6
In-114m (a)	1×10^1	5×10^{-1}	1×10^2	1×10^6
In-115m	7×10^0	1×10^0	1×10^2	1×10^6
Iridium (77)				
Ir-189 (a)	1×10^1	1×10^1	1×10^2	1×10^7

<i>Radionuclide (atomic number)</i>	<i>Special form A₁ (TBq)</i>	<i>Other form A₂ (TBq)</i>	<i>Activity concentration limit for exempt material (Bq/g)</i>	<i>Activity limit for an exempt consignment (Bq)</i>
Ir-190	7×10^{-1}	7×10^{-1}	1×10^1	1×10^6
Ir-192	1×10^0 (c)	6×10^{-1}	1×10^1	1×10^4
Ir-194	3×10^{-1}	3×10^{-1}	1×10^2	1×10^5
Potassium (19)				
K-40	9×10^{-1}	9×10^{-1}	1×10^2	1×10^6
K-42	2×10^{-1}	2×10^{-1}	1×10^2	1×10^6
K-43	7×10^{-1}	6×10^{-1}	1×10^1	1×10^6
Krypton (36)				
Kr-79	4×10^0	2×10^0	1×10^3	1×10^5
Kr-81	4×10^1	4×10^1	1×10^4	1×10^7
Kr-85	1×10^1	1×10^1	1×10^5	1×10^4
Kr-85m	8×10^0	3×10^0	1×10^3	1×10^{10}
Kr-87	2×10^{-1}	2×10^{-1}	1×10^2	1×10^9
Lanthanum (57)				
La-137	3×10^1	6×10^0	1×10^3	1×10^7
La-140	4×10^{-1}	4×10^{-1}	1×10^1	1×10^5
Lutetium (71)				
Lu-172	6×10^{-1}	6×10^{-1}	1×10^1	1×10^6
Lu-173	8×10^0	8×10^0	1×10^2	1×10^7
Lu-174	9×10^0	9×10^0	1×10^2	1×10^7
Lu-174m	2×10^1	1×10^1	1×10^2	1×10^7
Lu-177	3×10^1	7×10^{-1}	1×10^3	1×10^7
Magnesium (12)				
Mg-28 (a)	3×10^{-1}	3×10^{-1}	1×10^1	1×10^5
Manganese (25)				
Mn-52	3×10^{-1}	3×10^{-1}	1×10^1	1×10^5
Mn-53	Unlimited	Unlimited	1×10^4	1×10^9
Mn-54	1×10^0	1×10^0	1×10^1	1×10^6
Mn-56	3×10^{-1}	3×10^{-1}	1×10^1	1×10^5
Molybdenum (42)				
Mo-93	4×10^1	2×10^1	1×10^3	1×10^8
Mo-99 (a)	1×10^0	6×10^{-1}	1×10^2	1×10^6
Nitrogen (7)				
N-13	9×10^{-1}	6×10^{-1}	1×10^2	1×10^9
Sodium (11)				
Na-22	5×10^{-1}	5×10^{-1}	1×10^1	1×10^6
Na-24	2×10^{-1}	2×10^{-1}	1×10^1	1×10^5

<i>Radionuclide (atomic number)</i>	<i>Special form A₁ (TBq)</i>	<i>Other form A₂ (TBq)</i>	<i>Activity concentration limit for exempt material (Bq/g)</i>	<i>Activity limit for an exempt consignment (Bq)</i>
Niobium (41)				
Nb-93m	4×10^1	3×10^1	1×10^4	1×10^7
Nb-94	7×10^{-1}	7×10^{-1}	1×10^1	1×10^6
Nb-95	1×10^0	1×10^0	1×10^1	1×10^6
Nb-97	9×10^{-1}	6×10^{-1}	1×10^1	1×10^6
Neodymium (60)				
Nd-147	6×10^0	6×10^{-1}	1×10^2	1×10^6
Nd-149	6×10^{-1}	5×10^{-1}	1×10^2	1×10^6
Nickel (28)				
Ni-59	Unlimited	Unlimited	1×10^4	1×10^8
Ni-63	4×10^1	3×10^1	1×10^5	1×10^8
Ni-65	4×10^{-1}	4×10^{-1}	1×10^1	1×10^6
Neptunium (93)				
Np-235	4×10^1	4×10^1	1×10^3	1×10^7
Np-236 (short-lived)	2×10^1	2×10^0	1×10^3	1×10^7
Np-236 (long-lived)	9×10^0	2×10^{-2}	1×10^2	1×10^5
Np-237	2×10^1	2×10^{-3}	1×10^0 (b)	1×10^3 (b)
Np-239	7×10^0	4×10^{-1}	1×10^2	1×10^7
Osmium (76)				
Os-185	1×10^0	1×10^0	1×10^1	1×10^6
Os-191	1×10^1	2×10^0	1×10^2	1×10^7
Os-191m	4×10^1	3×10^1	1×10^3	1×10^7
Os-193	2×10^0	6×10^{-1}	1×10^2	1×10^6
Os-194 (a)	3×10^{-1}	3×10^{-1}	1×10^2	1×10^5
Phosphorus (15)				
P-32	5×10^{-1}	5×10^{-1}	1×10^3	1×10^5
P-33	4×10^1	1×10^0	1×10^5	1×10^8
Protactinium (91)				
Pa-230 (a)	2×10^0	7×10^{-2}	1×10^1	1×10^6
Pa-231	4×10^0	4×10^{-4}	1×10^0	1×10^3
Pa-233	5×10^0	7×10^{-1}	1×10^2	1×10^7
Lead (82)				
Pb-201	1×10^0	1×10^0	1×10^1	1×10^6
Pb-202	4×10^1	2×10^1	1×10^3	1×10^6
Pb-203	4×10^0	3×10^0	1×10^2	1×10^6
Pb-205	Unlimited	Unlimited	1×10^4	1×10^7
Pb-210 (a)	1×10^0	5×10^{-2}	1×10^1 (b)	1×10^4 (b)

<i>Radionuclide (atomic number)</i>	<i>Special form A₁ (TBq)</i>	<i>Other form A₂ (TBq)</i>	<i>Activity concentration limit for exempt material (Bq/g)</i>	<i>Activity limit for an exempt consignment (Bq)</i>
Pb-212 (a)	7×10^{-1}	2×10^{-1}	1×10^1 (b)	1×10^5 (b)
Palladium (46)				
Pd-103 (a)	4×10^1	4×10^1	1×10^3	1×10^8
Pd-107	Unlimited	Unlimited	1×10^5	1×10^8
Pd-109	2×10^0	5×10^{-1}	1×10^3	1×10^6
Promethium (61)				
Pm-143	3×10^0	3×10^0	1×10^2	1×10^6
Pm-144	7×10^{-1}	7×10^{-1}	1×10^1	1×10^6
Pm-145	3×10^1	1×10^1	1×10^3	1×10^7
Pm-147	4×10^1	2×10^0	1×10^4	1×10^7
Pm-148m (a)	8×10^{-1}	7×10^{-1}	1×10^1	1×10^6
Pm-149	2×10^0	6×10^{-1}	1×10^3	1×10^6
Pm-151	2×10^0	6×10^{-1}	1×10^2	1×10^6
Polonium (84)				
Po-210	4×10^1	2×10^{-2}	1×10^1	1×10^4
Praseodymium (59)				
Pr-142	4×10^{-1}	4×10^{-1}	1×10^2	1×10^5
Pr-143	3×10^0	6×10^{-1}	1×10^4	1×10^6
Platinum (78)				
Pt-188 (a)	1×10^0	8×10^{-1}	1×10^1	1×10^6
Pt-191	4×10^0	3×10^0	1×10^2	1×10^6
Pt-193	4×10^1	4×10^1	1×10^4	1×10^7
Pt-193m	4×10^1	5×10^{-1}	1×10^3	1×10^7
Pt-195m	1×10^1	5×10^{-1}	1×10^2	1×10^6
Pt-197	2×10^1	6×10^{-1}	1×10^3	1×10^6
Pt-197m	1×10^1	6×10^{-1}	1×10^2	1×10^6
Plutonium (94)				
Pu-236	3×10^1	3×10^{-3}	1×10^1	1×10^4
Pu-237	2×10^1	2×10^1	1×10^3	1×10^7
Pu-238	1×10^1	1×10^{-3}	1×10^0	1×10^4
Pu-239	1×10^1	1×10^{-3}	1×10^0	1×10^4
Pu-240	1×10^1	1×10^{-3}	1×10^0	1×10^3
Pu-241 (a)	4×10^1	6×10^{-2}	1×10^2	1×10^5
Pu-242	1×10^1	1×10^{-3}	1×10^0	1×10^4
Pu-244 (a)	4×10^{-1}	1×10^{-3}	1×10^0	1×10^4
Radium (88)				
Ra-223 (a)	4×10^{-1}	7×10^{-3}	1×10^2 (b)	1×10^5 (b)

<i>Radionuclide (atomic number)</i>	<i>Special form A₁ (TBq)</i>	<i>Other form A₂ (TBq)</i>	<i>Activity concentration limit for exempt material (Bq/g)</i>	<i>Activity limit for an exempt consignment (Bq)</i>
Ra-224 (a)	4×10^{-1}	2×10^{-2}	1×10^1 (b)	1×10^5 (b)
Ra-225 (a)	2×10^{-1}	4×10^{-3}	1×10^2	1×10^5
Ra-226 (a)	2×10^{-1}	3×10^{-3}	1×10^1 (b)	1×10^4 (b)
Ra-228 (a)	6×10^{-1}	2×10^{-2}	1×10^1 (b)	1×10^5 (b)
Rubidium (37)				
Rb-81	2×10^0	8×10^{-1}	1×10^1	1×10^6
Rb-83 (a)	2×10^0	2×10^0	1×10^2	1×10^6
Rb-84	1×10^0	1×10^0	1×10^1	1×10^6
Rb-86	5×10^{-1}	5×10^{-1}	1×10^2	1×10^5
Rb-87	Unlimited	Unlimited	1×10^4	1×10^7
Rb(nat)	Unlimited	Unlimited	1×10^4	1×10^7
Rhenium (75)				
Re-184	1×10^0	1×10^0	1×10^1	1×10^6
Re-184m	3×10^0	1×10^0	1×10^2	1×10^6
Re-186	2×10^0	6×10^{-1}	1×10^3	1×10^6
Re-187	Unlimited	Unlimited	1×10^6	1×10^9
Re-188	4×10^{-1}	4×10^{-1}	1×10^2	1×10^5
Re-189 (a)	3×10^0	6×10^{-1}	1×10^2	1×10^6
Re(nat)	Unlimited	Unlimited	1×10^6	1×10^9
Rhodium (45)				
Rh-99	2×10^0	2×10^0	1×10^1	1×10^6
Rh-101	4×10^0	3×10^0	1×10^2	1×10^7
Rh-102	5×10^{-1}	5×10^{-1}	1×10^1	1×10^6
Rh-102m	2×10^0	2×10^0	1×10^2	1×10^6
Rh-103m	4×10^1	4×10^1	1×10^4	1×10^8
Rh-105	1×10^1	8×10^{-1}	1×10^2	1×10^7
Radon (86)				
Rn-222 (a)	3×10^{-1}	4×10^{-3}	1×10^1 (b)	1×10^8 (b)
Ruthenium (44)				
Ru-97	5×10^0	5×10^0	1×10^2	1×10^7
Ru-103 (a)	2×10^0	2×10^0	1×10^2	1×10^6
Ru-105	1×10^0	6×10^{-1}	1×10^1	1×10^6
Ru-106 (a)	2×10^{-1}	2×10^{-1}	1×10^2 (b)	1×10^5 (b)
Sulphur (16)				
S-35	4×10^1	3×10^0	1×10^5	1×10^8
Antimony (51)				
Sb-122	4×10^{-1}	4×10^{-1}	1×10^2	1×10^4

<i>Radionuclide (atomic number)</i>	<i>Special form A₁ (TBq)</i>	<i>Other form A₂ (TBq)</i>	<i>Activity concentration limit for exempt material (Bq/g)</i>	<i>Activity limit for an exempt consignment (Bq)</i>
Sb-124	6×10^{-1}	6×10^{-1}	1×10^1	1×10^6
Sb-125	2×10^0	1×10^0	1×10^2	1×10^6
Sb-126	4×10^{-1}	4×10^{-1}	1×10^1	1×10^5
Scandium (21)				
Sc-44	5×10^{-1}	5×10^{-1}	1×10^1	1×10^5
Sc-46	5×10^{-1}	5×10^{-1}	1×10^1	1×10^6
Sc-47	1×10^1	7×10^{-1}	1×10^2	1×10^6
Sc-48	3×10^{-1}	3×10^{-1}	1×10^1	1×10^5
Selenium (34)				
Se-75	3×10^0	3×10^0	1×10^2	1×10^6
Se-79	4×10^1	2×10^0	1×10^4	1×10^7
Silicon (14)				
Si-31	6×10^{-1}	6×10^{-1}	1×10^3	1×10^6
Si-32	4×10^1	5×10^{-1}	1×10^3	1×10^6
Samarium (62)				
Sm-145	1×10^1	1×10^1	1×10^2	1×10^7
Sm-147	Unlimited	Unlimited	1×10^1	1×10^4
Sm-151	4×10^1	1×10^1	1×10^4	1×10^8
Sm-153	9×10^0	6×10^{-1}	1×10^2	1×10^6
Tin (50)				
Sn-113 (a)	4×10^0	2×10^0	1×10^3	1×10^7
Sn-117m	7×10^0	4×10^{-1}	1×10^2	1×10^6
Sn-119m	4×10^1	3×10^1	1×10^3	1×10^7
Sn-121m (a)	4×10^1	9×10^{-1}	1×10^3	1×10^7
Sn-123	8×10^{-1}	6×10^{-1}	1×10^3	1×10^6
Sn-125	4×10^{-1}	4×10^{-1}	1×10^2	1×10^5
Sn-126 (a)	6×10^{-1}	4×10^{-1}	1×10^1	1×10^5
Strontium (38)				
Sr-82 (a)	2×10^{-1}	2×10^{-1}	1×10^1	1×10^5
Sr-85	2×10^0	2×10^0	1×10^2	1×10^6
Sr-85m	5×10^0	5×10^0	1×10^2	1×10^7
Sr-87m	3×10^0	3×10^0	1×10^2	1×10^6
Sr-89	6×10^{-1}	6×10^{-1}	1×10^3	1×10^6
Sr-90 (a)	3×10^{-1}	3×10^{-1}	1×10^2 (b)	1×10^4 (b)
Sr-91 (a)	3×10^{-1}	3×10^{-1}	1×10^1	1×10^5
Sr-92 (a)	1×10^0	3×10^{-1}	1×10^1	1×10^6
Tritium (1)				

<i>Radionuclide (atomic number)</i>	<i>Special form A₁ (TBq)</i>	<i>Other form A₂ (TBq)</i>	<i>Activity concentration limit for exempt material (Bq/g)</i>	<i>Activity limit for an exempt consignment (Bq)</i>
T(H-3)	4×10^1	4×10^1	1×10^6	1×10^9
Tantalum (73)				
Ta-178 (long-lived)	1×10^0	8×10^{-1}	1×10^1	1×10^6
Ta-179	3×10^1	3×10^1	1×10^3	1×10^7
Ta-182	9×10^{-1}	5×10^{-1}	1×10^1	1×10^4
Terbium (65)				
Tb-157	4×10^1	4×10^1	1×10^4	1×10^7
Tb-158	1×10^0	1×10^0	1×10^1	1×10^6
Tb-160	1×10^0	6×10^{-1}	1×10^1	1×10^6
Technetium (43)				
Tc-95m (a)	2×10^0	2×10^0	1×10^1	1×10^6
Tc-96	4×10^{-1}	4×10^{-1}	1×10^1	1×10^6
Tc-96m (a)	4×10^{-1}	4×10^{-1}	1×10^3	1×10^7
Tc-97	Unlimited	Unlimited	1×10^3	1×10^8
Tc-97m	4×10^1	1×10^0	1×10^3	1×10^7
Tc-98	8×10^{-1}	7×10^{-1}	1×10^1	1×10^6
Tc-99	4×10^1	9×10^{-1}	1×10^4	1×10^7
Tc-99m	1×10^1	4×10^0	1×10^2	1×10^7
Tellurium (52)				
Te-121	2×10^0	2×10^0	1×10^1	1×10^6
Te-121m	5×10^0	3×10^0	1×10^2	1×10^6
Te-123m	8×10^0	1×10^0	1×10^2	1×10^7
Te-125m	2×10^1	9×10^{-1}	1×10^3	1×10^7
Te-127	2×10^1	7×10^{-1}	1×10^3	1×10^6
Te-127m (a)	2×10^1	5×10^{-1}	1×10^3	1×10^7
Te-129	7×10^{-1}	6×10^{-1}	1×10^2	1×10^6
Te-129m (a)	8×10^{-1}	4×10^{-1}	1×10^3	1×10^6
Te-131m (a)	7×10^{-1}	5×10^{-1}	1×10^1	1×10^6
Te-132 (a)	5×10^{-1}	4×10^{-1}	1×10^2	1×10^7
Thorium (90)				
Th-227	1×10^1	5×10^{-3}	1×10^1	1×10^4
Th-228 (a)	5×10^{-1}	1×10^{-3}	1×10^0 (b)	1×10^4 (b)
Th-229	5×10^0	5×10^{-4}	1×10^0 (b)	1×10^3 (b)
Th-230	1×10^1	1×10^{-3}	1×10^0	1×10^4
Th-231	4×10^1	2×10^{-2}	1×10^3	1×10^7
Th-232	Unlimited	Unlimited	1×10^1	1×10^4
Th-234 (a)	3×10^{-1}	3×10^{-1}	1×10^3 (b)	1×10^5 (b)

<i>Radionuclide (atomic number)</i>	<i>Special form A₁ (TBq)</i>	<i>Other form A₂ (TBq)</i>	<i>Activity concentration limit for exempt material (Bq/g)</i>	<i>Activity limit for an exempt consignment (Bq)</i>
Th(nat)	Unlimited	Unlimited	1×10^0 (b)	1×10^3 (b)
Titanium (22)				
Ti-44 (a)	5×10^{-1}	4×10^{-1}	1×10^1	1×10^5
Thallium (81)				
Tl-200	9×10^{-1}	9×10^{-1}	1×10^1	1×10^6
Tl-201	1×10^1	4×10^0	1×10^2	1×10^6
Tl-202	2×10^0	2×10^0	1×10^2	1×10^6
Tl-204	1×10^1	7×10^{-1}	1×10^4	1×10^4
Thulium (69)				
Tm-167	7×10^0	8×10^{-1}	1×10^2	1×10^6
Tm-170	3×10^0	6×10^{-1}	1×10^3	1×10^6
Tm-171	4×10^1	4×10^1	1×10^4	1×10^8
Uranium (92)				
U-230 (fast lung absorption) (a)(d)	4×10^1	1×10^{-1}	1×10^1 (b)	1×10^5 (b)
U-230 (medium lung absorption)(a)(e)	4×10^1	4×10^{-3}	1×10^1	1×10^4
U-230 (slow lung absorption) (a)(f)	3×10^1	3×10^{-3}	1×10^1	1×10^4
U-232 (fast lung absorption) (d)	4×10^1	1×10^{-2}	1×10^0 (b)	1×10^3 (b)
U-232 (medium lung absorption) (e)	4×10^1	7×10^{-3}	1×10^1	1×10^4
U-232 (slow lung absorption) (f)	1×10^1	1×10^{-3}	1×10^1	1×10^4
U-233 (fast lung absorption) (d)	4×10^1	9×10^{-2}	1×10^1	1×10^4
U-233 (medium lung absorption) (e)	4×10^1	2×10^{-2}	1×10^2	1×10^5
U-233 (slow lung absorption) (f)	4×10^1	6×10^{-3}	1×10^1	1×10^5
U-234 (fast lung absorption) (d)	4×10^1	9×10^{-2}	1×10^1	1×10^4
U-234 (medium lung absorption) (e)	4×10^1	2×10^{-2}	1×10^2	1×10^5
U-234 (slow lung absorption) (f)	4×10^1	6×10^{-3}	1×10^1	1×10^5
U-235 (all lung absorption types) (a),(d),(e),(f)	Unlimited	Unlimited	1×10^1 (b)	1×10^4 (b)
U-236 (fast lung absorption) (d)	Unlimited	Unlimited	1×10^1	1×10^4
U-236 (medium lung absorption) (e)	4×10^1	2×10^{-2}	1×10^2	1×10^5
U-236 (slow lung absorption) (f)	4×10^1	6×10^{-3}	1×10^1	1×10^4
U-238 (all lung absorption types) (d),(e),(f)	Unlimited	Unlimited	1×10^1 (b)	1×10^4 (b)
U (nat)	Unlimited	Unlimited	1×10^0 (b)	1×10^3 (b)
U (enriched to 20% or less) (g)	Unlimited	Unlimited	1×10^0	1×10^3
U (dep)	Unlimited	Unlimited	1×10^0	1×10^3
Vanadium (23)				
V-48	4×10^{-1}	4×10^{-1}	1×10^1	1×10^5
V-49	4×10^1	4×10^1	1×10^4	1×10^7
Tungsten (74)				

Radionuclide (atomic number)	Special form A_1 (TBq)	Other form A_2 (TBq)	Activity concentration limit for exempt material (Bq/g)	Activity limit for an exempt consignment (Bq)
W-178 (a)	9×10^0	5×10^0	1×10^1	1×10^6
W-181	3×10^1	3×10^1	1×10^3	1×10^7
W-185	4×10^1	8×10^{-1}	1×10^4	1×10^7
W-187	2×10^0	6×10^{-1}	1×10^2	1×10^6
W-188 (a)	4×10^{-1}	3×10^{-1}	1×10^2	1×10^5
Xenon (54)				
Xe-122 (a)	4×10^{-1}	4×10^{-1}	1×10^2	1×10^9
Xe-123	2×10^0	7×10^{-1}	1×10^2	1×10^9
Xe-127	4×10^0	2×10^0	1×10^3	1×10^5
Xe-131m	4×10^1	4×10^1	1×10^4	1×10^4
Xe-133	2×10^1	1×10^1	1×10^3	1×10^4
Xe-135	3×10^0	2×10^0	1×10^3	1×10^{10}
Yttrium (39)				
Y-87 (a)	1×10^0	1×10^0	1×10^1	1×10^6
Y-88	4×10^{-1}	4×10^{-1}	1×10^1	1×10^6
Y-90	3×10^{-1}	3×10^{-1}	1×10^3	1×10^5
Y-91	6×10^{-1}	6×10^{-1}	1×10^3	1×10^6
Y-91m	2×10^0	2×10^0	1×10^2	1×10^6
Y-92	2×10^{-1}	2×10^{-1}	1×10^2	1×10^5
Y-93	3×10^{-1}	3×10^{-1}	1×10^2	1×10^5
Ytterbium (70)				
Yb-169	4×10^0	1×10^0	1×10^2	1×10^7
Yb-175	3×10^1	9×10^{-1}	1×10^3	1×10^7
Zinc (30)				
Zn-65	2×10^0	2×10^0	1×10^1	1×10^6
Zn-69	3×10^0	6×10^{-1}	1×10^4	1×10^6
Zn-69m (a)	3×10^0	6×10^{-1}	1×10^2	1×10^6
Zirconium (40)				
Zr-88	3×10^0	3×10^0	1×10^2	1×10^6
Zr-93	Unlimited	Unlimited	1×10^3 (b)	1×10^7 (b)
Zr-95 (a)	2×10^0	8×10^{-1}	1×10^1	1×10^6
Zr-97 (a)	4×10^{-1}	4×10^{-1}	1×10^1 (b)	1×10^5 (b)

≠ (a) A_1 and/or A_2 values for these parent radionuclides include contributions from their progeny with half-lives less than 10 days, as listed in the following:

Mg-28	Al-28
Ar-42	K-42
Ca-47	Sc-47
Ti-44	Sc-44
Fe-52	Mn-52m
Fe-60	Co-60m

<i>Radionuclide (atomic number)</i>	<i>Special form A₁ (TBq)</i>	<i>Other form A₂ (TBq)</i>	<i>Activity concentration limit for exempt material (Bq/g)</i>	<i>Activity limit for an exempt consignment (Bq)</i>
Zn-69m	Zn-69			
Ge-68	Ga-68			
Rb-83	Kr-83m			
Sr-82	Rb-82			
Sr-90	Y-90			
Sr-91	Y-91m			
Sr-92	Y-92			
Y-87	Sr-87m			
Zr-95	Nb-95m			
Zr-97	Nb-97m, Nb-97			
Mo-99	Tc-99m			
Tc-95m	Tc-95			
Tc-96m	Tc-96			
Ru-103	Rh-103m			
Ru-106	Rh-106			
Pd-103	Rh-103m			
Ag-108m	Ag-108			
Ag-110m	Ag-110			
Cd-115	In-115m			
In-114m	In-114			
Sn-113	In-113m			
Sn-121m	Sn-121			
Sn-126	Sb-126m			
Te-118	Sb-118			
Te-127m	Te-127			
Te-129m	Te-129			
Te-131m	Te-131			
Te-132	I-132			
I-135	Xe-135m			
Xe-122	I-122			
Cs-137	Ba-137			
Ba-131	Cs-131			
Ba-140	La-140			
Ce-144	Pr-144m, Pr-144			
Pm-148m	Pm-148			
Gd-146	Eu-146			
Dy-166	Ho-166			
Hf-172	Lu-172			
W-178	Ta-178			
W-188	Re-188			
Re-189	Os-189m			
Os-194	Ir-194			
Ir-189	Os-189m			
Pt-188	Ir-188			
Hg-194	Au-194			
Hg-195m	Hg-195			
Pb-210	Bi-210			
Pb-212	Bi-212, Tl-208, Po-212			
Bi-210m	Tl-206			
Bi-212	Tl-208, Po-212			
At-211	Po-211			
Rn-222	Po-218, Pb-214, At-218, Bi-214, Po-214			
Ra-223	Rn-219, Po-215, Pb-211, Bi-211, Po-211, Tl-207			
Ra-224	Rn-220, Po-216, Pb-212, Bi-212, Tl-208, Po-212			
Ra-225	Ac-225, Fr-221, At-217, Bi-213, Tl-209, Po-213, Pb-209			
Ra-226	Rn-222, Po-218, Pb-214, At-218, Bi-214, Po-214			
Ra-228	Ac-228			
Ac-225	Fr-221, At-217, Bi-213, Tl-209, Po-213, Pb-209			
Ac-227	Fr-223			
Th-228	Ra-224, Rn-220, Po-216, Pb-212, Bi-212, Tl-208, Po-212			
Th-234	Pa-234m, Pa-234			
Pa-230	Ac-226, Th-226, Fr-222, Ra-222, Rn-218, Po-214			
U-230	Th-226, Ra-222, Rn-218, Po-214			
U-235	Th-231			
Pu-241	U-237			
Pu-244	U-240, Np-240m			
Am-242m	Am-242, Np-238			

Radionuclide (atomic number)	Special form A_1 (TBq)	Other form A_2 (TBq)	Activity concentration limit for exempt material (Bq/g)	Activity limit for an exempt consignment (Bq)
Am-243 Cm-247 Bk-249 Cf-253	Np-239 Pu-243 Am-245 Cm-249			
(b) Parent nuclides and their progeny included in secular equilibrium are listed in the following:				
Sr-90 Zr-93 Zr-97 Ru-106 Ag-108m Cs-137 Ce-144 Ba-140 Bi-212 Pb-210 Pb-212 Rn-222 Ra-223 Ra-224 Ra-226 Ra-228 Th-228 Th-229 Th-nat Th-234 U-230 U-232 U-235 U-238 U-nat Np-237 Am-242m Am-243	Y-90 Nb-93m Nb-97 Rh-106 Ag-108 Ba-137m Pr-144 La-140 Tl-208 (0.36), Po-212 (0.64) Bi-210, Po-210 Bi-212, Tl-208 (0.36), Po-212 (0.64) Po-218, Pb-214, Bi-214, Po-214 Rn-219, Po-215, Pb-211, Bi-211, Tl-207 Rn-220, Po-216, Pb-212, Bi-212, Tl-208 (0.36), Po-212 (0.64) Rn-222, Po-218, Pb-214, Bi-214, Po-214, Pb-210, Bi-210, Po-210 Ac-228 Ra-224, Rn-220, Po-216, Pb-212, Bi-212, Tl-208 (0.36), Po-212 (0.64) Ra-225, Ac-225, Fr-221, At-217, Bi-213, Po-213, Pb-209 Ra-228, Ac-228, Th-228, Ra-224, Rn-220, Po-216, Pb-212, Bi-212, Tl-208 (0.36), Po-212 (0.64) Pa-234m Th-226, Ra-222, Rn-218, Po-214 Th-228, Ra-224, Rn-220, Po-216, Pb-212, Bi-212, Tl-208 (0.36), Po-212 (0.64) Th-231 Th-234, Pa-234m Th-234, Pa-234m, U-234, Th-230, Ra-226, Rn-222, Po-218, Pb-214, Bi-214, Po-214, Pb-210, Bi-210, Po-210 Pa-233 Am-242 Np-239			
(c) The quantity may be determined from a measurement of the rate of decay or a measurement of the radiation level at a prescribed distance from the source.				
(d) These values apply only to compounds of uranium that take the chemical form of UF ₆ , UO ₂ F ₂ and UO ₂ (NO ₃) ₂ in both normal and accident conditions of transport.				
(e) These values apply only to compounds of uranium that take the chemical form of UO ₃ , UF ₄ , UCl ₄ and hexavalent compounds in both normal and accident conditions of transport.				
(f) These values apply to all compounds of uranium other than those specified in (d) and (e) above.				
(g) These values apply to unirradiated uranium only.				

Table 2-13. Basic radionuclide values for unknown radionuclides or mixtures

Radioactive contents	A_1 (TBq)	A_2 (TBq)	Activity concentration limit for exempt material (Bq/g)	Activity limit for an exempt consignment (Bq)
Only beta- or gamma-emitting nuclides are known to be present	0.1	0.02	1×10^1	1×10^4
Alpha-emitting nuclides but no neutron emitters are known to be present	0.2	9×10^{-5}	1×10^{-1}	1×10^3
Neutron-emitting nuclides are known to be present or no relevant data are available	0.001	9×10^{-5}	1×10^{-1}	1×10^3

7.2.3 Determination of other material characteristics

7.2.3.1 Low specific activity (LSA) material

7.2.3.1.1 (Reserved)

7.2.3.1.2 LSA material must be in one of three groups:

a) LSA-I

- ≠ i) uranium and thorium ores and concentrates of such ores, and other ores containing naturally occurring radionuclides;
- ii) natural uranium, depleted uranium, natural thorium, or their compounds or mixtures, that are unirradiated and in solid or liquid form;
- ≠ iii) radioactive material for which the A_2 value is unlimited. Fissile material may be included only if excepted under 7.2.3.5; or
- ≠ iv) other radioactive material in which the activity is distributed throughout and the estimated average specific activity does not exceed 30 times the values for activity concentration specified in 7.2.2.1 to 7.2.2.6. Fissile material may be included only if excepted under 7.2.3.5.

b) LSA-II

- ≠ i) water with tritium concentration up to 0.8 TBq/L;
- ii) other material in which the activity is distributed throughout and the estimated average specific activity does not exceed $10^{-4} A_2/g$ for solids and gases, and $10^{-5} A_2/g$ for liquids.

≠ c) LSA-III — solids (e.g. consolidated wastes, activated materials), excluding powders that meet the requirements of 7.2.3.1.3, in which:

- ≠ i) the radioactive material is distributed throughout a solid or a collection of solid objects, or is essentially uniformly distributed in a solid compact binding agent (such as concrete, bitumen and ceramic);
- ii) the radioactive material is relatively insoluble, or it is intrinsically contained in a relatively insoluble matrix, so that, even under loss of packaging, the loss of radioactive material per package by leaching when placed in water for seven days would not exceed $0.1 A_2$; and
- iii) the estimated average specific activity of the solid, excluding any shielding material, does not exceed $2 \times 10^{-3} A_2/g$.

7.2.3.1.3 LSA-III material must be a solid of such a nature that if the entire contents of a package were subjected to the test specified in 7.2.3.1.4, the activity in the water would not exceed $0.1 A_2$.

7.2.3.1.4 LSA-III material must be tested as follows:

A solid material sample representing the entire contents of the package must be immersed for 7 days in water at ambient temperature. The volume of water to be used in the test must be sufficient to ensure that at the end of the 7-day test period, the free volume of the unabsorbed and unreacted water remaining must be at least 10 per cent of the volume of the solid test sample itself. The water must have an initial pH of 6-8 and a maximum conductivity of 1 mS/m at 20°C. The total activity of the free volume of water must be measured following the 7-day immersion of the test sample.

7.2.3.1.5 Demonstration of compliance with the performance standards in 7.2.3.1.4 must be in accordance with 6;7.11.1 and 6;7.11.2.

7.2.3.2 Surface contaminated object (SCO)

7.2.3.2.1 SCO is classified in one of two groups:

a) SCO-I: A solid object on which:

- ≠ i) the non-fixed contamination on the accessible surface averaged over 300 cm^2 (or the area of the surface if less than 300 cm^2) does not exceed 4 Bq/cm^2 for beta and gamma emitters and low toxicity alpha emitters, or 0.4 Bq/cm^2 for all other alpha emitters;
- ≠ ii) the fixed contamination on the accessible surface averaged over 300 cm^2 (or the area of the surface if less than 300 cm^2) does not exceed $4 \times 10^4 \text{ Bq/cm}^2$ for beta and gamma emitters and low toxicity alpha emitters, or $4 \times 10^3 \text{ Bq/cm}^2$ for all other alpha emitters; or

- iii) the non-fixed contamination plus the fixed contamination on the inaccessible surface averaged over 300 cm² (or the area of the surface if less than 300 cm²) does not exceed 4×10^4 Bq/cm² for beta and gamma emitters and low toxicity alpha emitters, or 4×10^3 Bq/cm² for all other alpha emitters;
- b) SCO-II: A solid object on which either the fixed or non-fixed contamination on the surface exceeds the applicable limits specified for SCO-I in a) above and on which:
 - ≠ i) the non-fixed contamination on the accessible surface averaged over 300 cm² (or the area of the surface if less than 300 cm²) does not exceed 400 Bq/cm² for beta and gamma emitters and low toxicity alpha emitters, or 40 Bq/cm² for all other alpha emitters;
 - ≠ ii) the fixed contamination on the accessible surface, averaged over 300 cm² (or the area of the surface if less than 300 cm²) does not exceed 8×10^5 Bq/cm² for beta and gamma emitters and low toxicity alpha emitters, or 8×10^4 Bq/cm² for all other alpha emitters; or
 - iii) the non-fixed contamination plus the fixed contamination on the inaccessible surface averaged over 300 cm² (or the area of the surface if less than 300 cm²) does not exceed 8×10^5 Bq/cm² for beta and gamma emitters and low toxicity alpha emitters, or 8×10^4 Bq/cm² for all other alpha emitters.

7.2.3.3 Special form radioactive material

7.2.3.3.1 Special form radioactive material must have at least one dimension not less than 5 mm. When a sealed capsule constitutes part of the special form radioactive material, the capsule must be so manufactured that it can be opened only by destroying it. The design for special form radioactive material requires unilateral approval.

7.2.3.3.2 Special form radioactive material must be of such a nature or must be so designed that if it is subjected to the tests specified in 7.2.3.3.4 to 7.2.3.3.8, it must meet the following requirements:

- a) it would not break or shatter under the impact, percussion and bending tests specified in 7.2.3.3.5 a), b), c) or 7.2.3.3.6 a), as applicable; and
- ≠ b) it would not melt or disperse in the applicable heat test specified in 7.2.3.3.5 d) or 7.2.3.3.6 b), as applicable; and
- c) the activity in the water from the leaching tests specified in 7.2.3.3.7 and 7.2.3.3.8 would not exceed 2 kBq; or alternatively for sealed sources, the leakage rate for the volumetric leakage assessment test specified in ISO 9978:1992 "Radiation Protection — Sealed Radioactive Sources — Leakage Test Methods", would not exceed the applicable acceptance threshold acceptable to the competent authority.

7.2.3.3.3 Demonstration of compliance with the performance standards in 7.2.3.3.2 must be in accordance with 6;7.11.1 and 6;7.11.2.

7.2.3.3.4 Specimens that comprise or simulate special form radioactive material must be subjected to the impact test, the percussion test, the bending test, and the heat test specified in 7.2.3.3.5 or alternative tests as authorized in 7.2.3.3.6. A different specimen may be used for each of the tests. Following each test, a leaching assessment or volumetric leakage test must be performed on the specimen by a method no less sensitive than the methods given in 7.2.3.3.7 for indispersible solid material or 7.2.3.3.8 for encapsulated material.

7.2.3.3.5 The relevant test methods are:

- a) Impact test: The specimen must drop onto the target from a height of 9 m. The target must be as defined in 6;7.13;
- b) Percussion test: The specimen must be placed on a sheet of lead which is supported by a smooth, solid surface and struck by the flat face of a mild steel bar so as to cause an impact equivalent to that resulting from a free drop of 1.4 kg through 1 m. The lower part of the bar must be 25 mm in diameter with the edges rounded off to a radius of (3.0 ± 0.3) mm. The lead, of hardness number 3.5 to 4.5 on the Vickers scale and not more than 25 mm thick, must cover an area greater than that covered by the specimen. A fresh surface of lead must be used for each impact. The bar must strike the specimen so as to cause maximum damage.
- c) Bending test: The test must apply only to long, slender sources with both a minimum length of 10 cm and a length to minimum width ratio of not less than 10. The specimen must be rigidly clamped in a horizontal position so that one-half of its length protrudes from the face of the clamp. The orientation of the specimen must be such that the specimen will suffer maximum damage when its free end is struck by the flat face of a steel bar. The bar must strike the specimen so as to cause an impact equivalent to that resulting from a free vertical drop of 1.4 kg through 1 m. The lower part of the bar must be 25 mm in diameter with the edges rounded off to a radius of (3.0 ± 0.3) mm.
- d) Heat test: The specimen must be heated in air to a temperature of 800°C and held at that temperature for a period of 10 minutes and must then be allowed to cool.

7.2.3.3.6 Specimens that comprise or simulate radioactive material enclosed in a sealed capsule may be excepted from:

- ≠ a) the tests prescribed in 7.2.3.3.5 a) and b) provided that the specimens are alternatively subjected to the impact test prescribed in ISO 2919:2012: "Radiation Protection — Sealed Radioactive Sources — General requirements and classification":
 - ≠ i) the Class 4 impact test if the mass of the special form radioactive material is less than 200 g; or
 - ≠ ii) the Class 5 impact test if the mass of the special form radioactive material is 200 g or more but less than 500 g; and
- ≠ b) the test prescribed in 7.2.3.3.5 d) provided the specimens are alternatively subjected to the Class 6 temperature test specified in ISO ISO 2919:2012 "Radiation protection — Sealed radioactive sources — General requirements and classification".

7.2.3.3.7 For specimens which comprise or simulate indispersible solid material, a leaching assessment must be performed as follows:

- a) The specimen must be immersed for 7 days in water at ambient temperature. The volume of water to be used in the test must be sufficient to ensure that at the end of the 7-day test period, the free volume of the unabsorbed and unreacted water remaining must be at least 10 per cent of the volume of the solid test sample itself. The water must have an initial pH of 6-8 and a maximum conductivity of 1 mS/m at 20°C;
- b) The water with the specimen must then be heated to a temperature of $(50 \pm 5)^\circ\text{C}$ and maintained at this temperature for 4 hours;
- c) The activity of the water must then be determined;
- d) The specimen must then be kept for at least 7 days in still air at not less than 30°C and relative humidity not less than 90 per cent;
- e) The specimen must then be immersed in water of the same specification as in a) above and the water with the specimen heated to $(50 \pm 5)^\circ\text{C}$ and maintained at this temperature for 4 hours;
- f) The activity of the water must then be determined.

7.2.3.3.8 For specimens which comprise or simulate radioactive material enclosed in a sealed capsule, either a leaching assessment or a volumetric leakage assessment must be performed as follows:

- a) The leaching assessment must consist of the following steps:
 - i) the specimen must be immersed in water at ambient temperature. The water must have an initial pH of 6-8 with a maximum conductivity of 1 mS/m at 20°C;
 - ii) the water and specimen must be heated to a temperature of $(50 \pm 5)^\circ\text{C}$ and maintained at this temperature for 4 hours;
 - iii) the activity of the water must then be determined;
 - iv) the specimen must then be kept for at least 7 days in still air at not less than 30°C and relative humidity of not less than 90 per cent;
 - v) the process in i), ii) and iii) must be repeated;
- ≠ b) The alternative volumetric leakage assessment must comprise any of the tests prescribed in ISO 9978:1992 "Radiation protection — Sealed radioactive sources — Leakage test methods", provided that they are acceptable to the competent authority.

7.2.3.4 Low dispersible radioactive material

7.2.3.4.1 The design for low dispersible radioactive material requires multilateral approval. Low dispersible radioactive material must be such that the total amount of this radioactive material in a package, taking into account the provisions of 6;7.7.14, must meet the following requirements:

- a) The radiation level at 3 m from the unshielded radioactive material does not exceed 10 mSv/h;
- b) If subjected to the tests specified in 6;7.19.3 and 6;7.19.4, the airborne release in gaseous and particulate forms of up to 100 μm aerodynamic equivalent diameter would not exceed 100 A_2 . A separate specimen may be used for each test; and
- c) If subjected to the test specified in 7.2.3.1.4, the activity in the water would not exceed 100 A_2 . In the application of this test, the damaging effects of the tests specified in b) above must be taken into account.

7.2.3.4.2 Low dispersible material must be tested as follows:

A specimen that comprises or simulates low dispersible radioactive material must be subjected to the enhanced thermal test specified in 6;7.19.3 and the impact test specified in 6;7.19.4. A different specimen may be used for each of the tests. Following each test, the specimen must be subjected to the leach test specified in 7.2.3.1.4. After each test, it must be determined if the applicable requirements of 7.2.3.4.1 have been met.

7.2.3.4.3 Demonstration of compliance with the performance standards in 7.2.3.4.1 and 7.2.3.4.2 must be in accordance with 6;7.11.1 and 6;7.11.2.

7.2.3.5 *Fissile material*

≠ 7.2.3.5.1 Fissile material and packages containing fissile material must be classified under the relevant entry as fissile in accordance with Table 2-11 unless excepted by one of the provisions of sub-paragraphs a) to f) below and transported subject to the requirements of 7;2.9.4.3. All provisions apply only to material in packages that meets the requirements of 6;7.6.2.

>
≠ a) Uranium enriched in uranium-235 to a maximum of 1 per cent by mass, and with a total plutonium and uranium-233 content not exceeding 1 per cent of the mass of uranium-235, provided that the fissile nuclides are distributed essentially homogeneously throughout the material. In addition, if uranium-235 is present in metallic, oxide or carbide forms, it must not form a lattice arrangement;

≠ b) Liquid solutions of uranyl nitrate enriched in uranium-235 to a maximum of 2 per cent by mass, with a total plutonium and uranium-233 content not exceeding 0.002 per cent of the mass of uranium, and with a minimum nitrogen to uranium atomic ratio (N/U) of 2;

+ c) Uranium with a maximum uranium enrichment of 5 per cent by mass uranium-235 provided:

i) there is no more than 3.5 g of uranium-235 per package;

ii) the total plutonium and uranium-233 content does not exceed 1 per cent of the mass of uranium-235 per package;

iii) transport of the package is subject to the consignment limit provided in 7;2.9.4.3 c);

+ d) Fissile nuclides with a total mass not greater than 2 g per package provided the package is transported subject to the consignment limit provided in 7;2.9.4.3 d);

+ e) Fissile nuclides with a total mass not greater than 45 g subject to limits provided in 7;2.9.4.3 e);

+ f) A fissile material that meets the requirements of 7;2.9.4.3 b), 7.2.3.6 and 5;1.2.2.1.

+ 7.2.3.6 A fissile material excepted from classification as fissile under 7.2.3.5.1 f) must be subcritical without the need for accumulation control under the following conditions:

a) the conditions of 6;7.10.1 a);

b) the conditions consistent with the assessment provisions stated in 6;7.10.12 b) and 6;7.10.13 b) for packages; and

c) the conditions specified in 6;7.10.11 a).

7.2.4 Classification of packages

7.2.4.1 The quantity of radioactive material in a package must not exceed the relevant limits for the package type as specified below.

7.2.4.1.1 Classification as excepted packages

≠ 7.2.4.1.1.1 A package may be classified as excepted packages if it meets one of the following conditions:

≠ a) it is an empty packaging having contained radioactive material;

≠ b) it contains instruments or articles not exceeding the activity limits specified in columns 2 and 3 of Table 2-14;

≠ c) it contains articles manufactured of natural uranium, depleted uranium or natural thorium; or

≠ d) it contains radioactive material not exceeding the activity limits specified in column 4 of Table 2-14; or

+ e) it contains less than 0.1 kg of uranium hexafluoride not exceeding the activity limits specified in column 4 of Table 2-14.

7.2.4.1.1.2 A package containing radioactive material may be classified as an excepted package provided that the radiation level at any point on its external surface does not exceed 5 µSv/h.

- ≠ 7.2.4.1.1.3 Radioactive material which is enclosed in or is included as a component part of an instrument or other manufactured article may be classified under UN 2911 — **Radioactive material, excepted package — instruments or articles** provided that:
- a) the radiation level at 10 cm from any point on the external surface of any unpackaged instrument or article is not greater than 0.1 mSv/h; and
- ≠ b) each instrument or article bears the marking "RADIOACTIVE" on its external surface except for the following:
- i) radioluminescent time-pieces or devices;
- ≠ ii) consumer products that either have received regulatory approval in accordance with 1;6.1.4 c) or do not individually exceed the activity limit for an exempt consignment in Table 2-12 (column 5), provided such products are transported in a package that bears the marking "RADIOACTIVE" on an internal surface in such a manner that a warning of the presence of radioactive material is visible on opening the package; and
- + iii) other instruments or articles too small to bear the marking "RADIOACTIVE", provided that they are transported in a package that bears the marking "RADIOACTIVE" on its internal surface in such a manner that a warning of the presence of radioactive material is visible on opening the package;
- c) the active material is completely enclosed by non-active components (a device performing the sole function of containing radioactive material must not be considered to be an instrument or manufactured article); and
- ≠ d) the limits specified in columns 2 and 3 of Table 2-14 are met for each individual item and each package, respectively.
- ≠ 7.2.4.1.1.4 Radioactive material in forms other than as specified in 7.2.4.1.1.3 and with an activity not exceeding the limits specified in column 4 of Table 2-14 may be classified under UN 2910 — **Radioactive material, excepted package — limited quantity of material**, provided that:
- a) the package retains its radioactive contents under routine conditions of transport; and
- ≠ b) the package bears the marking "RADIOACTIVE" on either:
- i) an internal surface in such a manner that a warning of the presence of radioactive material is visible on opening the package; or
- + ii) the outside of the package, where it is impractical to mark an internal surface.
- + 7.2.4.1.1.5 Uranium hexafluoride not exceeding the limits specified in column 4 of Table 2-14 may be classified under UN 3507 — **Uranium hexafluoride, radioactive material, excepted package**, less than 0.1 kg per package, non-fissile or fissile-excepted provided that:
- a) the mass of uranium hexafluoride in the package is less than 0.1 kg; and
 - b) the conditions of 7.2.4.5.2 and 7.2.4.1.1.4 a) and b) are met.
- ≠ 7.2.4.1.1.6 Articles manufactured of natural uranium, depleted uranium or natural thorium and articles in which the sole radioactive material is unirradiated natural uranium, unirradiated depleted uranium or unirradiated natural thorium may be classified under UN 2909, **Radioactive material, excepted package — articles manufactured from natural uranium or depleted uranium or natural thorium** provided that the outer surface of the uranium or thorium is enclosed in an inactive sheath made of metal or some other substantial material.
- ≠ 7.2.4.1.1.7 An empty packaging which had previously contained radioactive material may be classified under UN 2908 — **Radioactive material, excepted package — empty packaging** provided that:
- a) it is in a well-maintained condition and securely closed;
 - b) the outer surface of any uranium or thorium in its structure is covered with an inactive sheath made of metal or some other substantial material;
 - c) the level of internal non-fixed contamination, when averaged over any 300 cm², does not exceed:
 - i) 400 Bq/cm² for beta and gamma emitters and low toxicity alpha emitters; and
 - ii) 40 Bq/cm² for all other alpha emitters; and
 - d) any labels which may have been displayed on it in conformity with 5;3.2.6 are no longer visible.

+ *Note.— The external radiation levels at the surface of empty Type B(U) or Type B(M) packages may exceed 5 $\mu\text{Sv/h}$ due to the presence of depleted uranium in the shielding material. Such empty packages cannot be transported as UN 2908 — **Radioactive material, excepted package — empty packaging** as they do not meet the conditions specified in 7.2.4.1.1.2. These packages remain subject to all applicable parts of these Instructions and may be classified as:*

- a) *low specific material (LSA-I) as specified in 7.2.3.1.2 a) ii); or*
- b) *Type B(U) package as specified in 7.2.4.6.2; or*
- c) *Type B(M) package as specified in 7.2.4.6.3.*

≠ **Table 2-14. Activity limits for excepted packages**

Physical state of contents	Instruments or article		Materials
	Item limits*	Package limits*	Package limits*
Solids			
Special form	$10^{-2} A_1$	A_1	$10^{-3} A_1$
Other form	$10^{-2} A_2$	A_2	$10^{-3} A_2$
Liquids	$10^{-3} A_2$	$10^{-1} A_2$	$10^{-4} A_2$
Gases			
Tritium	$2 \times 10^{-2} A_2$	$2 \times 10^{-1} A_2$	$2 \times 10^{-2} A_2$
Special form	$10^{-3} A_1$	$10^{-2} A_1$	$10^{-3} A_1$
Other forms	$10^{-3} A_2$	$10^{-2} A_2$	$10^{-3} A_2$

* For mixtures of radionuclides, see 7.2.2.4 to 7.2.2.6.

7.2.4.2 Classification as low specific activity (LSA) material

7.2.4.2.1 Radioactive material may only be classified as LSA material if the definition of LSA in 7.1.3 and the conditions of 7.2.3.1, 4;9.2.1 and 7;2.9.2 are met.

7.2.4.3 Classification as surface contaminated object (SCO)

7.2.4.3.1 Radioactive material may be classified as SCO if the definition of SCO in 7.1.3 and the conditions of 7.2.3.2, 4;9.2.1 and 7;2.9.2 are met.

7.2.4.4 Classification of Type A packages

7.2.4.4.1 Packages containing radioactive material may be classified as Type A packages provided that the following conditions are met:

≠ 7.2.4.4.1.1 Type A packages must not contain activities greater than either of the following:

- ≠ a) for special form radioactive material — A_1 ;
- b) for all other radioactive material — A_2 .

7.2.4.4.1.2 For mixtures of radionuclides whose identities and respective activities are known, the following condition must apply to the radioactive contents of a Type A package:

$$\sum_i \frac{B(i)}{A_1(i)} + \sum_j \frac{C(j)}{A_2(j)} \leq 1$$

where

B(i) is the activity of radionuclide i as special form radioactive material;

A₁(i) is the A₁ value for radionuclide i;

C(j) is the activity of radionuclide j as other than special form radioactive material;

A₂(j) is the A₂ value for radionuclide j.

7.2.4.5 Classification of uranium hexafluoride

7.2.4.5.1 Uranium hexafluoride must only be assigned to:

- ≠ a) UN 2977 — Radioactive material, uranium hexafluoride, fissile; or
- ≠ b) UN 2978 — **Radioactive material, uranium hexafluoride**, non-fissile or fissile excepted; or
- + c) UN 3507 — **Uranium hexafluoride, radioactive material, excepted package**, less than 0.1 kg per package, non-fissile or fissile-excepted.

≠ 7.2.4.5.2 The contents of a package containing uranium hexafluoride must comply with the following requirements:

- ≠ a) for UN Nos. 2977 and 2978, the mass of uranium hexafluoride must not be different from that allowed for the package design, and for UN 3507, the mass of uranium hexafluoride must be less than 0.1 kg;
- ≠ b) the mass of uranium hexafluoride must not be greater than a value that would lead to an ullage smaller than 5 per cent at the maximum temperature of the package as specified for the plant systems where the package will be used; and
- ≠ c) the uranium hexafluoride must be in solid form and the internal pressure must not be above atmospheric pressure when presented for transport.

7.2.4.6 Classification as Type B(U), Type B(M) or Type C packages

≠ 7.2.4.6.1 Packages not otherwise classified in 7.2.4 (7.2.4.1.1 to 7.2.4.5) must be classified in accordance with the competent authority certificate of approval for the package issued by the country of origin of design.

≠ 7.2.4.6.2 The contents of a Type B(U), Type B(M) or Type C package must be as specified in the certificate of approval.

>
>

7.2.5 Special arrangements

Radioactive material must be classified as transported under special arrangement when it is intended to be transported in accordance with 1;6.4.

Chapter 8

CLASS 8 — CORROSIVE SUBSTANCES

8.1 DEFINITION OF CLASS 8

Class 8 substances (corrosive substances) are substances which, by chemical action, will cause severe damage when in contact with living tissue or, in the case of leakage, will materially damage, or even destroy, other goods or the means of transport.

8.2 ASSIGNMENT OF PACKING GROUPS

8.2.1 Substances and preparations of Class 8 are divided among the three packing groups according to their degree of hazard in transport as follows:

- a) Packing Group I: Very dangerous substances and preparations;
- b) Packing Group II : Substances and preparations presenting medium danger;
- c) Packing Group III: Substances and preparations presenting minor danger.

8.2.2 Allocation of substances in Class 8 to the packing groups referred to in the introduction to Part 3, Chapter 1 has been on the basis of experience, taking into account such additional factors as inhalation risk and reactivity with water, including the formation of hazardous decomposition products. New substances, including mixtures, can be assigned to packing groups on the basis of the length of time of contact necessary to produce full thickness destruction of human skin. Liquids, and solids which may become liquid during transport, which are judged not to cause full thickness destruction of human skin must still be considered for their potential to cause corrosion to certain metal surfaces in accordance with the criteria in 8.2.5 c) ii).

8.2.3 A substance or preparation meeting the criteria of Class 8 having an inhalation toxicity of dusts and mists (LC₅₀) in the range of Packing Group I, but toxicity through oral ingestion or dermal contact only in the range of Packing Group III or less, must be allocated to Class 8.

8.2.4 In assigning the packing group to a substance in accordance with 8.2.2, account must be taken of human experience in instances of accidental exposure. In the absence of human experience, the packing group must be based on data obtained from experiments in accordance with OECD Guideline for the Testing of Chemicals No. 404, *Acute Dermal Irritation/Corrosion*, 2002 or No. 435, *In Vitro Membrane Barrier Test Method for Skin Corrosion*, 2006. A substance which is determined not to be corrosive in accordance with OECD Guideline for the Testing of Chemicals No. 430, *In Vitro Skin Corrosion: Transcutaneous Electrical Resistance Test (TER)*, 2004 or No. 431, *In Vitro Skin Corrosion: Human Skin Model Test*, 2004 may be considered not to be corrosive to skin for the purposes of these Instructions without further testing.

8.2.5 Packing groups are assigned to corrosive substances in accordance with the following criteria:

- a) *Packing Group I* is assigned to substances that cause full thickness destruction of intact skin tissue within an observation period of up to 60 minutes starting after an exposure time of 3 minutes or less.
- b) *Packing Group II* is assigned to substances that cause full thickness destruction of intact skin tissue within an observation period of up to 14 days starting after an exposure time of more than 3 minutes but not more than 60 minutes.
- c) *Packing Group III* is assigned to substances that:
 - i) cause full thickness destruction of intact skin tissue within an observation period of up to 14 days starting after an exposure time of more than 60 minutes but not more than 4 hours;
 - ii) are judged not to cause full thickness destruction of intact skin tissue but which exhibit a corrosion rate on either steel or aluminium surfaces exceeding 6.25 mm a year at a test temperature of 55°C when tested on both materials. For the purposes of testing steel, type S235JR+CR (1.0037 resp. St 37-2), S275J2G3+CR (1.0144 resp. St 44-3), ISO 3574, Unified Numbering System (UNS) G10200 or SAE 1020, and for testing aluminium, non-clad types 7075-T6 or AZ5GU-T6, must be used. An acceptable test is prescribed in the UN *Manual of Tests and Criteria*, Part III, Section 37.

Note.— Where an initial test on either steel or aluminium indicates the substance being tested is corrosive, the follow up test on the other metal is not required.

Table 2-15. Summary of criteria for assigning packing groups to corrosive substances

<i>Packing group</i>	<i>Exposure time</i>	<i>Observation period</i>	<i>Effect</i>
I	≤ 3 min	≤ 60 min	Full thickness destruction of intact skin
II	> 3 min ≤ 1 h	≤ 14 d	Full thickness destruction of intact skin
III	> 1 h ≤ 4 h	≤ 14 d	Full thickness destruction of intact skin
III	—	—	Corrosion rate on either steel or aluminium surfaces exceeding 6.25 mm a year at a test temperature of 55°C when tested on both materials

Chapter 9

CLASS 9 — MISCELLANEOUS DANGEROUS SUBSTANCES AND ARTICLES, INCLUDING ENVIRONMENTALLY HAZARDOUS SUBSTANCES

Parts of this Chapter are affected by State Variations DE 5, NL 4; see Table A-1

9.1 DEFINITION

9.1.1 *Class 9 substances and articles (miscellaneous dangerous substances and articles)* are substances and articles which, during air transport, present a danger not covered by other classes.

9.1.2 *Genetically modified micro-organisms (GMMOs) and genetically modified organisms (GMOs)* are micro-organisms and organisms in which genetic material has been purposely altered through genetic engineering in a way that does not occur naturally.

9.2 ASSIGNMENT TO CLASS 9

9.2.1 Class 9 includes, inter alia:

- a) Environmentally hazardous substances (aquatic environment) are those that meet the criteria in 2.9.3 of the UN Model Regulations or that meet criteria in international regulations or national regulations established by the appropriate national authority in the State of Origin, transit or destination of the consignment.

Substances or mixtures dangerous to the aquatic environment not otherwise classified under these Instructions must be assigned to Packing Group III and designated:

UN 3077 Environmentally hazardous substance, solid, n.o.s.; or
UN 3082 Environmentally hazardous substance, liquid, n.o.s.

- b) Elevated temperature substances (i.e. substances that are transported or offered for transport at temperatures equal to or exceeding 100°C in a liquid state or at temperatures equal to or exceeding 240°C in a solid state (these substances may only be carried under 1;1.1)).
- c) GMMOs or GMOs which do not meet the definition of toxic substances (see 6.2) or infectious substances (see 6.3) must be assigned to UN 3245. GMMOs or GMOs are not subject to these Instructions when authorized for use by the appropriate national authorities of the States of Origin, transit and destination. Genetically modified live animals must be transported under terms and conditions of the appropriate national authorities of the States of Origin and destination.
- d) Magnetized material: Any material which, when packed for air transport, has a maximum magnetic field strength sufficient to cause a compass deflection of more than 2 degrees at a distance of 2.1 m from any point on the surface of the assembled package. The magnetic field strength at the compass producing a 2 degree deflection is taken to be 0.418 A/m (0.00525 Gauss).

The magnetic field strength must be measured with a magnetic compass sensitive enough to read a 2 degree variation, preferably in 1 degree increments or finer, or using a Gauss meter having a sensitivity sufficient to measure magnetic fields greater than 0.0005 Gauss within a tolerance of plus or minus 5 per cent, or by an equivalent means.

Compass measurements must be taken in an area free from magnetic interference other than the Earth's magnetic field. When using a compass, the material and the compass must be aligned in an east-west direction. Gauss meter measurements must be in accordance with the manufacturer's instructions. Measurements are taken while the packaged material is rotated through 360 degrees in its horizontal plane while maintaining a constant distance (2.1 m or 4.6 m as referred to in Packing Instruction 953) between the measuring device and any point on the outside surface of the package. Shielding may be used to reduce the package's magnetic strength.

Note.— Masses of ferro-magnetic metals such as automobiles, automobile parts, metal fencing, piping and metal construction material, even if not meeting the definition of magnetized material may affect aircraft compasses, as may packages or items which individually do not meet the definition of magnetized material but cumulatively may have a magnetic field strength of a magnetized material.

- e) Aviation regulated solid or liquid: Any material which has narcotic, noxious or other properties such that, in the event of spillage or leakage on an aircraft, extreme annoyance or discomfort could be caused to crew members so as to prevent the correct performance of assigned duties.

Some examples of articles in Class 9 are:

- Engines, internal combustion;
- Life-saving appliances, self-inflating;
- Battery-powered equipment or vehicle.

Some examples of substances in Class 9 are:

- ≠ — Asbestos, amphibole (amosite, tremolite, actinolite, anthophyllite, crocidolite)
- + — Asbestos, chrysotile
- Carbon dioxide, solid (dry ice);
- Zinc dithionite.

9.3 LITHIUM BATTERIES

9.3.1 Cells and batteries, cells and batteries contained in equipment, or cells and batteries packed with equipment, containing lithium in any form must be assigned to UN Nos. 3090, 3091, 3480 or 3481 as appropriate. They may be transported under these entries if they meet the following provisions:

- a) each cell or battery is of the type proved to meet the requirements of each test of the UN *Manual of Tests and Criteria*, Part III, subsection 38.3;
- + Cells and batteries manufactured according to a type meeting the requirements of subsection 38.3 of the UN *Manual of Tests and Criteria*, Revision 3, Amendment 1 or any subsequent revision and amendment applicable at the date of the type testing may continue to be transported, unless otherwise provided in these Instructions.
- + Cell and battery types only meeting the requirements of the UN Manual of Tests and Criteria, Revision 3, are no longer valid. However, cells and batteries manufactured in conformity with such types before 1 July 2003 may continue to be transported if all other applicable requirements are fulfilled.
- ≠ *Note.— Batteries must be of a type proved to meet the testing requirements of the UN Manual of Tests and Criteria, Part III, subsection 38.3, irrespective of whether the cells of which they are composed are of a tested type.*
- > b) each cell and battery incorporates a safety venting device or is designed to preclude a violent rupture under conditions normally incident to transport;
- c) each cell and battery is equipped with an effective means of preventing external short circuits;
- d) each battery containing cells or a series of cells connected in parallel is equipped with effective means as necessary to prevent dangerous reverse current flow (e.g. diodes, fuses, etc.);
- e) cells and batteries must be manufactured under a quality management programme that includes:
 - 1) a description of the organizational structure and responsibilities of personnel with regard to design and product quality;
 - 2) the relevant inspection and test, quality control, quality assurance, and process operation instructions that will be used;
 - 3) process controls that should include relevant activities to prevent and detect internal short circuit failure during manufacture of cells;
 - 4) quality records, such as inspection reports, test data, calibration data and certificates. Test data must be kept and made available to the appropriate national authority upon request;
 - 5) management reviews to ensure the effective operation of the quality management programme;
 - 6) a process for control of documents and their revision;
 - 7) a means for control of cells or batteries that are not conforming to the type tested in accordance with Part III, subsection 38.3 of the UN *Manual of Tests and Criteria*;

- 8) training programmes and qualification procedures for relevant personnel; and
- 9) procedures to ensure that there is no damage to the final product.

Note.— In-house quality management programmes may be accepted. Third-party certification is not required, but the procedures listed in 1) to 9) above must be properly recorded and traceable. A copy of the quality management programme must be made available to the appropriate national authority upon request.

Part 3

**DANGEROUS GOODS LIST,
SPECIAL PROVISIONS AND
LIMITED AND EXCEPTED QUANTITIES**

Chapter 1

GENERAL

Parts of this Chapter are affected by State Variations US 3, ZA 1; see Table A-1

1.1 GENERAL

1.1.1 The Dangerous Goods List (Table 3-1) in this Chapter lists the dangerous goods most commonly carried but is not exhaustive. It is intended that the list cover, as far as practicable, all dangerous substances of commercial importance.

1.1.2 Where an article or substance is specifically listed by name in the Dangerous Goods List, it must be transported in accordance with the provisions in the List which are appropriate for that article or substance. A “generic” or “not otherwise specified” entry may be used to permit the transport of substances or articles which do not appear specifically by name in the Dangerous Goods List. Such a substance or article may be transported only after its dangerous properties have been determined. The substance or article must then be classified according to the class definitions and test criteria and the name in the Dangerous Goods List which most appropriately describes the substance must be used. The classification must be made by the appropriate national authority when so required or may otherwise be made by the shipper. Once the class of the substance or article has been so established, all conditions for dispatch and transport, as provided in these Instructions must be met. Any substance or article having or suspected of having explosive characteristics must first be considered for inclusion in Class 1.

1.1.3 The List also includes a number of specific articles and substances whose transport by air is forbidden (see Part 1, Chapter 2).

1.1.4 Where precautionary measures are laid down in the Dangerous Goods List in respect of a given substance or article (e.g. that it must be “stabilized” or “with x% water or phlegmatizer”) such substance or article may not normally be carried when these measures have not been taken, unless the item in question is listed elsewhere (e.g. Class 1) without any indication of, or with different, precautionary measures.

1.1.5 Where there is any doubt as to whether a non-listed article or substance is permitted for transport by air, or under what conditions, the shipper and/or operator must consult an appropriate specialized agency.

1.2 PROPER SHIPPING NAME

Note.— For proper shipping names used for the transport of samples, see Part 2, Introductory Chapter, paragraph 5.

1.2.1 The proper shipping name is that portion of the entry most accurately describing the goods in the Dangerous Goods List, which is shown in boldface characters (plus any numbers, Greek letters, “sec”, “tert”, and the letters m, n, o, p, which form an integral part of the name). Portions of an entry appearing in lightface type need not be considered as part of the proper shipping name but may be used.

1.2.2 Proper shipping names may be used in the singular or plural as appropriate. In addition, when qualifying words are used as part of the proper shipping name, their sequence on documentation or package markings is optional. For instance, “**Dimethylamine solution**” may alternatively be shown as “**Solution of Dimethylamine**”. However, the entry in column 1 reflects the preferred sequence. Alternative spelling reflecting common usage around the world is acceptable for words such as “**caesium**” for “**cesium**”, “**sulfur**” for “**sulphur**”, “**aluminum**” for “**aluminium**”, etc. However, the spelling appearing in Table 3-1 is preferred.

1.2.3 Many substances have an entry for both the liquid and solid state (see definitions for liquid and solid in 1;3.1.1) or for the solid and solution. These are allocated separate UN numbers.

1.2.4 Unless it is already included in bold letters in the name indicated in the Dangerous Goods List, the qualifying word “**molten**” must be added as part of the proper shipping name when a substance, which is a solid in accordance with the definition in 1;3.1, is offered for transport in the molten state (e.g. **Alkylphenol, solid, n.o.s., molten**).

1.2.5 Except for self-reactive substances and organic peroxides and unless it is already included in boldface characters in the name indicated in column 1 of the Dangerous Goods List, the word “**stabilized**” must be added as part of the proper shipping name of a substance which without stabilization would be forbidden from transport in accordance with 1;2.1 due to it being liable to react dangerously under conditions normally encountered in transport (e.g. “**Toxic liquid, organic, n.o.s., stabilized**”).

1.2.6 Hydrates may be transported under the proper shipping name for the anhydrous substance.

1.2.7 Generic or “not otherwise specified” (n.o.s.) names

1.2.7.1 Generic and “not otherwise specified” proper shipping names, indicated by the inclusion of an asterisk in column 1 of the Dangerous Goods List, must be supplemented with the technical or chemical group names unless a national law or international convention prohibits their disclosure if it is a controlled substance. For explosives of Class 1, the dangerous goods description may be supplemented by additional descriptive text to indicate commercial or military names. Technical and chemical group names must be entered in brackets immediately following the proper shipping name. An appropriate modifier, such as “contains” or “containing” or other qualifying words such as “mixture”, “solution”, etc. and the percentage of the technical constituent may be used. For example: “UN 1993 **Flammable liquid, n.o.s.** (contains xylene and benzene), 3, PG II”.

1.2.7.1.1 The technical name must be a recognized chemical or biological name or other name currently used in scientific and technical handbooks, journals and texts. Trade names must not be used for this purpose. In the case of pesticides, only ISO common name(s), other name(s) in the World Health Organization (WHO) *Recommended Classification of Pesticides by Hazard and Guidelines to Classification*, or the name(s) of the active substance(s) may be used.

1.2.7.1.2 When a mixture of dangerous goods is described by one of the “n.o.s.” or “generic” entries where an asterisk is indicated in column 1 of the Dangerous Goods List, not more than the two constituents which most predominantly contribute to the hazard or hazards of a mixture need to be shown, excluding controlled substances when their disclosure is prohibited by national law or international convention. If a package containing a mixture is labelled with any subsidiary risk label, one of the two technical names as shown in parentheses must be the name of the constituent which compels the use of the subsidiary risk label.

Examples illustrating the selection of the proper shipping name supplemented with the technical name of the dangerous goods for such n.o.s. entries are:

UN 3394 **Organometallic substance, liquid, pyrophoric, water-reactive** (Trimethylgallium)
UN 2902 **Pesticide, liquid, toxic, n.o.s.** (Drazoxolon).

Note. — As an aid to choosing the most appropriate n.o.s. or generic name, all the n.o.s. entries and the main generic entries of Table 3-1 are listed in Attachment 1, Chapter 2.

1.3 MIXTURES OR SOLUTIONS

Note.— Where a substance is specifically listed by name in Table 3-1, it must be identified in transport by the proper shipping name in Table 3-1. Such substances may contain technical impurities (for example, those deriving from the production process) or additives for stability or other purposes that do not affect its classification. However, a substance listed by name containing technical impurities or additives for stability or other purposes affecting its classification must be considered a mixture or solution (see Part 2, Introductory Chapter, paragraphs 3.2 and 3.5).

1.3.1 A mixture or solution is not subject to these Instructions if the characteristics, properties, form or physical state of the mixture or solution are such that it does not meet the criteria, including human experience criteria, for inclusion in any class.

1.3.2 A mixture or solution meeting the classification criteria of these Instructions composed of a single predominant substance identified by name in Table 3-1 and one or more substances not subject to these Instructions and/or traces of one or more substances identified by name in Table 3-1 must be assigned the UN number and proper shipping name of the predominant substance named in Table 3-1, unless:

- the mixture or solution is specifically identified by name in Table 3-1 in which case this name must be applied; or
- the name and description of the substance named in Table 3-1 specifically indicates that it applies only to the pure substance; or
- the hazard class or division, subsidiary risk(s), physical state or packing group of the solution or mixture is different from that of the substance named in Table 3-1; or
- the hazard characteristics and properties of the mixture or solution necessitate emergency response measures that are different from those required for the substance identified by name in Table 3-1.

If b), c) or d) is applicable, the mixture or solution must be treated as a substance not specifically listed by name in Table 3-1.

Note.— Although traces of substances may not need to be taken into account for classification purposes, those traces may affect the properties of the substance and do need to be taken into account when considering the compatibility requirements of 4.1.1.3.

1.3.3 Qualifying words such as “**solution**” or “**mixture**”, as appropriate, must be added as part of the proper shipping name, e.g. “**Acetone solution**”. In addition, the concentration of the solution or mixture may also be indicated after the basic description of the mixture or solution, e.g. “**Acetone 75% solution**”.

1.3.4 A mixture or solution meeting the classification criteria of these Instructions that is not identified by name in Table 3-1 and that is composed of two or more dangerous goods must be assigned to an entry that has the proper shipping name, description, hazard class or division, subsidiary risk(s) and packing group that most precisely describe the solution or mixture.

Chapter 2

ARRANGEMENT OF THE DANGEROUS GOODS LIST (TABLE 3-1)

Parts of this Chapter are affected by State Variations AU 1, AU 2, AU 3, BE 3, CA 7, CA 8, HR 3, IR 3, KP 2, MO 2, NL 1, RO 3, US 2, US 3, US 6, US 15, ZA 1; see Table A-1

2.1 ARRANGEMENT OF THE DANGEROUS GOODS LIST (TABLE 3-1)

2.1.1 The Dangerous Goods List (Table 3-1) is divided into 13 columns as follows:

- Column 1 “Name” — this column contains the alphabetically arranged list of dangerous goods, identified by their proper shipping names in boldface characters (see 1.2). Also included, in lightface type, are:
- other names by which certain articles and substances may be known; in such cases a cross reference to the proper shipping name is given;
 - names of articles and substances which are forbidden for carriage by air under any circumstances; and
 - names of articles and substances which are subject to additional considerations under special provisions.

An explanation of some of the terms used appears in Attachment 2.

Entries in this column have been arranged in alphabetical order; where names comprise more than one word, they have been alphabetized as if they were a single word. In deciding the correct order, numbers and the terms n.o.s., alpha-, beta-, meta-, omega-, sec-, tert-, a-, b-, m-, N-, n-, O-, o- and p- have been ignored. Similarly, the word “see” and any words following it have been ignored.

Unless otherwise indicated, for an entry in the dangerous goods list, the word “solution” in a proper shipping name means one or more named dangerous goods dissolved in a liquid that is not otherwise subject to these Instructions.

- Column 2 “UN No.” — this column contains the serial number assigned to the article or substance under the United Nations classification system. Some entries in the list have not been assigned such a number and for these, a temporary identification number (ID) in the 8000 series has been allocated and is indicated where appropriate. Numbers in the 8000 series must be identified with the “ID” prefix instead of the “UN” prefix used when identifying all other numbers for marking and documentation in these Technical Instructions. When the word “Forbidden” appears across this column and column 3, it means that the dangerous goods covered by that particular entry meet the description of dangerous goods forbidden on aircraft under any circumstances, as provided in 1;2.1. It must be noted, however, that all dangerous goods meeting this description have not been included in the Dangerous Goods List.
- Column 3 “Class or division” — this column contains the class or division and in the case of Class 1, the compatibility group assigned to the article or substance according to the classification system described in Part 2; Introductory Chapter.
- Column 4 “Subsidiary risk” — this column contains the class or division number of any important subsidiary risks which have been identified by applying the classification found in Part 2; Chapters 1 to 9. Requirements for the labelling of dangerous goods which have subsidiary risks are given in 5;3.2.
- Column 5 “Labels” — this column specifies the class hazard label followed by the subsidiary risk label(s) (after the symbol “&”) to be applied to each outside packaging and overpack. Subsidiary risk labels are not shown for all n.o.s. or generic articles and substances which possess more than one hazard. When such an article or substance has more than one hazard and no subsidiary risk label is indicated in column 5 of Table 3-1, subsidiary risk labels must be applied in accordance with 5;3.2.2 and 5;3.2.3. For magnetized material the required handling label is also shown. In the instances where no label is required the word “None” will appear.
- Column 6 “State variations” — this column contains references to entries in Attachment 3, which shows State variations from these Instructions (these appear under the designator and name of the State).

- Column 7 “Special provisions” — this column contains a number referring to the appropriate entries in Table 3-2. Special provisions apply to all the packing groups permitted for a particular substance or article unless the wording makes it otherwise apparent.
- Column 8 “UN packing group” — this column contains the UN packing group number (i.e. I, II or III) assigned to the article or substance. If more than one packing group is indicated for the entry, the packing group of the substance or formulation to be transported should be determined, based on its properties, through application of the hazard grouping criteria as provided in Part 2.
- ≠ Column 9 “Excepted quantities” — this column provides an alphanumeric code described in 5.1.2 which indicates the maximum quantity per inner and outer packaging for transporting dangerous goods as excepted quantities in accordance with Part 3, Chapter 5.
- ≠ Column 10 “Passenger and cargo aircraft — Packing instruction” — this column refers to the relevant packing instructions listed in Part 4 for transport of the article or substance on a passenger aircraft. For some entries an alternative packing instruction is shown prefixed with the letter “Y”. Such packing instructions are for limited quantities of dangerous goods.
- ≠ Column 11 “Passenger and cargo aircraft — Maximum net quantity per package” — this column shows the maximum net quantity (mass or volume) of the article or substance allowed in each package for transport on a passenger aircraft. Where a maximum net quantity appears beside a packing instruction prefixed by the letter “Y”, this indicates it is the maximum net quantity permitted in a packaging containing limited quantities of dangerous goods unless indicated by a letter “G” where the mass quoted is the total mass of the package. The maximum quantity per package may be further limited by the type of packaging used. The maximum net quantities indicated may be exceeded only if specified in these Instructions or as permitted in the Supplement to these Instructions in S-3;2 with the approval of the appropriate national authority of the State of Origin and the State of the Operator.
- ≠ Column 12 “Cargo aircraft only — Packing instruction” — this column provides information similar to that in column 10, but for articles or substances which may be transported on a cargo aircraft only.
- ≠ Column 13 “Cargo aircraft only — Maximum net quantity per package” — this column provides information similar to that in column 11, but for articles or substances which may be transported on a cargo aircraft only. The maximum quantity per package may be further limited by the type of packaging used. The maximum net quantities indicated do not apply to transport in portable tanks, as permitted in the Supplement to these Instructions, Part S-4, Chapter 12, with the approval of the appropriate authority of the State of Origin and the State of the Operator. The maximum net quantities indicated may be exceeded only if specified in these Instructions or as permitted in the Supplement to these Instructions in S-3;2 with the approval of the appropriate national authority of the State of Origin and the State of the Operator.

≠ *Note 1.— Where an article or substance may not be carried on a passenger aircraft, the word “FORBIDDEN” is written across columns 10 and 11. Where an article or substance may not be carried on any aircraft, the word “FORBIDDEN” is written across columns 12 and 13 as well as across columns 10 and 11.*

Note 2.— Where an article or substance is packed according to the packing instruction and maximum net quantity per package given in columns 10 and 11, it may also be carried on a cargo aircraft. In such circumstances, the package must not bear the “Cargo aircraft only” label referred to in 5;3.2.12 a).

2.1.2 The following abbreviations or symbols are used in Table 3-1 and have the meanings shown:

Abbreviation	Column	Meaning
n.o.s.	1	Not otherwise specified
L	11 and 13	Litre(s)
kg	11 and 13	Kilogram(s)
G	11	Gross mass of package as prepared for transport
*	1	Entry which requires the addition of a technical name according to 1.2.7
†	1	Entry for which there is an explanation in Attachment 2
≠		this symbol indicates changed text
+		this symbol indicates new or relocated text
>		this symbol indicates deleted text

Table 3-1. Dangerous Goods List

Name	UN No.	Class or division	Subsidiary risk	Labels	State variations	Special provisions	UN packing group	Excepted quantity	Passenger and cargo aircraft		Cargo aircraft only	
									Packing instruction	Max. net quantity per package	Packing instruction	Max. net quantity per package
1	2	3	4	5	6	7	8	9	10	11	12	13
A												
Accumulators, electric, see Batteries , etc. (UN Nos. 2794, 2795, 2800, 3028, 3292)												
Acetal	1088	3		Liquid flammable			II	E2	353 Y341	5 L 1 L	364	60 L
Acetaldehyde	1089	3		Liquid flammable	AU 1 CA 7 IR 3 NL 1 US 3	A1	I	E0	FORBIDDEN		361	30 L
Acetaldehyde ammonia	1841	9		Miscellaneous			III	E1	956	200 kg	956	200 kg
Acetaldehyde oxime	2332	3		Liquid flammable			III	E1	355 Y344	60 L 10 L	366	220 L
Acetic acid, glacial	2789	8	3	Corrosive & Liquid flammable			II	E2	851 Y840	1 L 0.5 L	855	30 L
Acetic acid solution , more than 80% acid, by mass	2789	8	3	Corrosive & Liquid flammable			II	E2	851 Y840	1 L 0.5 L	855	30 L
Acetic acid solution , more than 10% but less than 50% acid, by mass	2790	8		Corrosive			III	E1	852 Y841	5 L 1 L	856	60 L
Acetic acid solution , not less than 50% but not more than 80% acid, by mass	2790	8		Corrosive			II	E2	851 Y840	1 L 0.5 L	855	30 L
Acetic anhydride	1715	8	3	Corrosive & Liquid flammable			II	E2	851 Y840	1 L 0.5 L	855	30 L
Acetoin, see Acetyl methyl carbinol												
Acetone	1090	3		Liquid flammable			II	E2	353 Y341	5 L 1 L	364	60 L
Acetone cyanohydrin, stabilized	1541	6.1			AU 1 CA 7 IR 3 NL 1 US 3 US 4	A2			FORBIDDEN		FORBIDDEN	
Acetone oils	1091	3		Liquid flammable			II	E2	353 Y341	5 L 1 L	364	60 L

Name	UN No.	Class or division	Subsidiary risk	Labels	State variations	Special provisions	UN packing group	Excepted quantity	Passenger and cargo aircraft		Cargo aircraft only	
									Packing instruction	Max. net quantity per package	Packing instruction	Max. net quantity per package
1	2	3	4	5	6	7	8	9	10	11	12	13
Acetonitrile	1648	3		Liquid flammable			II	E2	353 Y341	5 L 1 L	364	60 L
Acetyl bromide	1716	8		Corrosive			II	E2	851 Y840	1 L 0.5 L	855	30 L
Acetyl chloride	1717	3	8	Liquid flammable & Corrosive			II	E2	352 Y340	1 L 0.5 L	363	5 L
Acetyl cyclohexanesulphonyl peroxide, more than 82%, wetted with less than 12% water	FORBIDDEN											
Acetylene, dissolved	1001	2.1		Gas flammable	AU 1 CA 7 NL 1 US 3	A1		E0	FORBIDDEN		200	15 kg
Acetylene (liquefied)	FORBIDDEN											
Acetylene silver nitrate	FORBIDDEN											
Acetylene, solvent free	3374	2.1		Gas flammable	AU 1 CA 7 IR 3 NL 1 US 3	A1		E0	FORBIDDEN		200	15 kg
Acetylene tetrabromide, see Tetrabromoethane												
Acetylene tetrachloride, see 1,1,2,2-Tetrachloroethane												
Acetyl iodide	1898	8		Corrosive			II	E2	851 Y840	1 L 0.5 L	855	30 L
Acetyl methyl carbinol	2621	3		Liquid flammable			III	E1	355 Y344	60 L 10 L	366	220 L
Acid butyl phosphate, see Butyl acid phosphate												
Acid mixture, hydrofluoric and sulphuric, see Hydrofluoric acid and sulphuric acid mixture												
Acid mixture, nitrating acid, see Nitrating acid mixture												
Acid mixture, spent, nitrating acid, see Nitrating acid mixture, spent												

Name	UN No.	Class or division	Subsidiary risk	Labels	State variations	Special provisions	UN packing group	Excepted quantity	Passenger and cargo aircraft		Cargo aircraft only	
									Packing instruction	Max. net quantity per package	Packing instruction	Max. net quantity per package
1	2	3	4	5	6	7	8	9	10	11	12	13
Acraldehyde, inhibited, see Acrolein, stabilized												
Acridine	2713	6.1		Toxic			III	E1	670 Y645	100 kg 10 kg	677	200 kg
Acrolein dimer, stabilized	2607	3		Liquid flammable			III	E1	355 Y344	60 L 10 L	366	220 L
Acrolein, stabilized	1092	6.1	3						FORBIDDEN		FORBIDDEN	
Acrylamide, solid	2074	6.1		Toxic			III	E1	670 Y645	100 kg 10 kg	677	200 kg
Acrylamide solution	3426	6.1		Toxic		A3	III	E1	655 Y642	60 L 2 L	663	220 L
Acrylic acid, stabilized	2218	8	3	Corrosive & Liquid flammable			II	E2	851 Y840	1 L 0.5 L	855	30 L
Acrylonitrile, stabilized	1093	3	6.1	Liquid flammable & Toxic			I	E0	FORBIDDEN		361	30 L
≠ Actinolite, see Asbestos, amphibole (UN No. 2212)												
Activated carbon, see Carbon, activated												
Activated charcoal, see Carbon, activated												
Actuating cartridge, explosive, see Cartridges, power device (UN Nos. 0275, 0276, 0323, 0381)												
Adhesives containing flammable liquid	1133	3		Liquid flammable		A3	I II III	E3 E2 E1	351 353 Y341 355 Y344	1 L 5 L 1 L 60 L 10 L	361 364 366	30 L 60 L 220 L
Adiponitrile	2205	6.1		Toxic			III	E1	655 Y642	60 L 2 L	663	220 L
+ Adsorbed gas, n.o.s.*	3511	2.2		Gas non-flammable				E0	219	75 kg	219	150 kg
+ Adsorbed gas, flammable, n.o.s.*	3510	2.1		Gas flammable				E0	FORBIDDEN		219	150 kg
+ Adsorbed gas, oxidizing, n.o.s.*	3513	2.2	5.1	Gas non-flammable & Oxidizer				E0	219	75 kg	219	150 kg
+ Adsorbed gas, toxic, n.o.s.*	3512	2.3				A2		E0	FORBIDDEN		FORBIDDEN	
+ Adsorbed gas, toxic, corrosive, n.o.s.*	3516	2.3	8			A2		E0	FORBIDDEN		FORBIDDEN	
+ Adsorbed gas, toxic, flammable, n.o.s.*	3514	2.3	2.1			A2		E0	FORBIDDEN		FORBIDDEN	

Name	UN No.	Class or division	Subsidiary risk	Labels	State variations	Special provisions	UN packing group	Excepted quantity	Passenger and cargo aircraft		Cargo aircraft only	
									Packing instruction	Max. net quantity per package	Packing instruction	Max. net quantity per package
1	2	3	4	5	6	7	8	9	10	11	12	13
+ Adsorbed gas, toxic, flammable, corrosive, n.o.s.*	3517	2.3	2.1 8			A2		E0	FORBIDDEN		FORBIDDEN	
+ Adsorbed gas, toxic, oxidizing, n.o.s.*	3515	2.3	5.1			A2		E0	FORBIDDEN		FORBIDDEN	
+ Adsorbed gas, toxic, oxidizing, corrosive, n.o.s.*	3518	2.3	5.1 8			A2		E0	FORBIDDEN		FORBIDDEN	
Aeroplane flares, see Flares, aerial												
Aerosols, flammable	1950	2.1		Gas flammable		A145 A167		E0	203 Y203	75 kg 30 kg G	203	150 kg
Aerosols, flammable, containing substances in Division 6.1, Packing Group II	1950	2.1	6.1						FORBIDDEN		FORBIDDEN	
Aerosols, flammable, containing substances in Division 6.1, Packing Group III and substances in Class 8, Packing Group III	1950	2.1	6.1 8	Gas flammable & Toxic & Corrosive		A145 A167		E0	203 Y203	75 kg 30 kg G	203	150 kg
Aerosols, flammable, containing toxic gas	1950	2.3	2.1						FORBIDDEN		FORBIDDEN	
Aerosols, flammable, corrosive, containing substances in Class 8, Packing Group II	1950	2.1	8						FORBIDDEN		FORBIDDEN	
Aerosols, flammable, corrosive, containing substances in Class 8, Packing Group III	1950	2.1	8	Gas flammable & Corrosive		A145 A167		E0	203 Y203	75 kg 30 kg G	203	150 kg
Aerosols, flammable (engine starting fluid)	1950	2.1		Gas flammable	AU 1 CA 7 IR 3 NL 1 US 3	A1 A145 A167		E0	FORBIDDEN		203	150 kg
Aerosols, flammable, toxic, containing substances in Division 6.1, Packing Group III	1950	2.1	6.1	Gas flammable & Toxic		A145 A167		E0	203 Y203	75 kg 30 kg G	203	150 kg
Aerosols, non-flammable	1950	2.2		Gas non-flammable		A98 A145 A167		E0	203 or 204 Y203 or Y204	75 kg 30 kg G	203 or 204	150 kg
Aerosols, non-flammable, containing substances in Class 8, Packing Group II	1950	2.2	8						FORBIDDEN		FORBIDDEN	
Aerosols, non-flammable, containing substances in Division 6.1, Packing Group III and substances in Class 8, Packing Group III	1950	2.2	6.1 8	Gas non-flammable & Toxic & Corrosive		A145 A167		E0	203 Y203	75 kg 30 kg G	203	150 kg

Chapter 2

3-2-7

Name	UN No.	Class or division	Subsidiary risk	Labels	State variations	Special provisions	UN packing group	Excepted quantity	Passenger and cargo aircraft		Cargo aircraft only	
									Packing instruction	Max. net quantity per package	Packing instruction	Max. net quantity per package
1	2	3	4	5	6	7	8	9	10	11	12	13
Aerosols , non-flammable, containing substances in Division 6.1, Packing Group II (other than tear gas devices)	1950	2.2	6.1						FORBIDDEN		FORBIDDEN	
Aerosols , non-flammable, containing toxic gas	1950	2.3							FORBIDDEN		FORBIDDEN	
Aerosols , non-flammable, corrosive, containing substances in Class 8, Packing Group III	1950	2.2	8	Gas non-flammable & Corrosive		A145 A167		E0	203 Y203	75 kg 30 kg G	203	150 kg
Aerosols , non-flammable (tear gas devices)	1950	2.2	6.1	Gas non-flammable & Toxic	AU 1 CA 7 IR 3 NL 1 US 3	A1 A145 A167		E0	FORBIDDEN		212	50 kg
Aerosols , non-flammable, toxic, containing substances in Division 6.1, Packing Group III	1950	2.2	6.1	Gas non-flammable & Toxic		A145 A167		E0	203 Y203	75 kg 30 kg G	203	150 kg
Aerosols , oxidizing	1950	2.2	5.1	Gas non-flammable & Oxidizer		A145 A167		E0	203	75 kg	203	150 kg
Agent, blasting, type B †	0331	1.5D							FORBIDDEN		FORBIDDEN	
Agent, blasting, type E †	0332	1.5D							FORBIDDEN		FORBIDDEN	
>												
>												
+ Air bag inflators, see Safety devices (UN No. 3268) or Safety devices, pyrotechnic (UN No. 0503)												
>												
>												
+ Air bag modules, see Safety devices (UN No. 3268) or Safety devices, pyrotechnic (UN No. 0503)												
Air, compressed	1002	2.2		Gas non-flammable				E1	200	75 kg	200	150 kg
Aircraft, see Vehicle (flammable gas powered) or Vehicle (flammable liquid powered)												

Name	UN No.	Class or division	Subsidiary risk	Labels	State variations	Special provisions	UN packing group	Excepted quantity	Passenger and cargo aircraft		Cargo aircraft only	
									Packing instruction	Max. net quantity per package	Packing instruction	Max. net quantity per package
1	2	3	4	5	6	7	8	9	10	11	12	13
Aircraft engines (including turbines) †, see Engines, internal combustion (UN No. 3166)												
≠ Aircraft evacuation slides, see Life-saving appliances, self-inflating (UN No. 2990)												
Aircraft hydraulic power unit fuel tank (containing a mixture of anhydrous hydrazine and methyl hydrazine) (M86 fuel)	3165	3	6.1 8	Liquid flammable & Toxic & Corrosive	AU 1 CA 7 IR 3 NL 1 US 3	A1 A48	I	E0	FORBIDDEN		372	42 L
≠ Aircraft survival kits, see Life-saving appliances, self-inflating (UN No. 2990)												
≠ Air, refrigerated liquid	1003	2.2	5.1	Gas non-flammable & Oxidizer	AU 1 CA 7 IR 3 NL 1 US 3	A1		E0	FORBIDDEN		202	150 kg
Alcoholates solution, n.o.s.* , in alcohol	3274	3	8	Liquid flammable & Corrosive			II	E2	352 Y340	1 L 0.5 L	363	5 L
Alcohol, denatured, see Alcohols, n.o.s. or Alcohols, flammable, toxic, n.o.s.												
Alcoholic beverages containing more than 70% alcohol by volume	3065	3		Liquid flammable			II	E2	353 Y341	5 L 1 L	364	60 L
Alcoholic beverages containing more than 24% but not more than 70% alcohol by volume	3065	3		Liquid flammable		A9 A58	III	E1	355 Y344	60 L 10 L	366	220 L
Alcohol, industrial, see Alcohols, n.o.s. or Alcohols, toxic, flammable, n.o.s.												
Alcohols, n.o.s.*	1987	3		Liquid flammable		A3 A180	II III	E2 E1	353 Y341 355 Y344	5 L 1 L 60 L 10 L	364 366	60 L 220 L

Name	UN No.	Class or division	Subsidiary risk	Labels	State variations	Special provisions	UN packing group	Excepted quantity	Passenger and cargo aircraft		Cargo aircraft only	
									Packing instruction	Max. net quantity per package	Packing instruction	Max. net quantity per package
1	2	3	4	5	6	7	8	9	10	11	12	13
Alcohols, flammable, toxic, n.o.s.*	1986	3	6.1	Liquid flammable & Toxic		A3	I	E0	FORBIDDEN		361	30 L
								E2	352	1 L	364	60 L
								E1	Y341	1 L		
									355	60 L	366	220 L
									Y343	2 L		
Aldehyde, see Aldehydes, n.o.s. (UN No. 1989)												
Aldehydes, n.o.s.*	1989	3		Liquid flammable		A3	I	E3	351	1 L	361	30 L
								E2	353	5 L	364	60 L
								E1	Y341	1 L		
									355	60 L	366	220 L
									Y344	10 L		
Aldehydes, flammable, toxic, n.o.s.*	1988	3	6.1	Liquid flammable & Toxic		A3	I	E0	FORBIDDEN		361	30 L
								E2	352	1 L	364	60 L
								E1	Y341	1 L		
									355	60 L	366	220 L
									Y343	2 L		
Aldol	2839	6.1		Toxic			II	E4	654	5 L	662	60 L
									Y641	1 L		
Alkali metal alcoholates, self-heating, corrosive, n.o.s.*	3206	4.2	8	Spontaneous combustion & Corrosive		A3	II	E2	466	15 kg	470	50 kg
								E1	A84	468	25 kg	471
Alkali metal alloy, liquid, n.o.s.	1421	4.3		Danger if wet		A84	I	E0	FORBIDDEN		480	1 L
Alkali metal amalgam, liquid	1389	4.3		Danger if wet		A84	I	E0	FORBIDDEN		480	1 L
Alkali metal amalgam, solid	3401	4.3		Danger if wet		A84	I	E0	FORBIDDEN		487	15 kg
Alkali metal amides	1390	4.3		Danger if wet		A84	II	E2	483	15 kg	489	50 kg
									Y475	5 kg		
Alkali metal dispersion	1391	4.3		Danger if wet		A84	I	E0	FORBIDDEN		480	1 L
Alkali metal dispersion, flammable	3482	4.3	3	Danger if wet & Liquid flammable		A84	I	E0	FORBIDDEN		480	1 L
Alkaline corrosive battery fluid, see Battery fluid, alkali												
Alkaline earth metal alcoholates, n.o.s.*	3205	4.2		Spontaneous combustion		A3	II	E2	467	15 kg	470	50 kg
								E1	A85	469	25 kg	471
Alkaline earth metal alloy, n.o.s.	1393	4.3		Danger if wet		A85	II	E2	484	15 kg	490	50 kg
									Y475	5 kg		
Alkaline earth metal amalgam, liquid	1392	4.3		Danger if wet		A85	I	E0	FORBIDDEN		480	1 L
Alkaline earth metal amalgam, solid	3402	4.3		Danger if wet		A85	I	E0	FORBIDDEN		487	15 kg
Alkaline earth metal dispersion	1391	4.3		Danger if wet		A85	I	E0	FORBIDDEN		480	1 L

Name	UN No.	Class or division	Subsidiary risk	Labels	State variations	Special provisions	UN packing group	Excepted quantity	Passenger and cargo aircraft		Cargo aircraft only	
									Packing instruction	Max. net quantity per package	Packing instruction	Max. net quantity per package
1	2	3	4	5	6	7	8	9	10	11	12	13
Alkaline earth metal dispersion, flammable	3482	4.3	3	Danger if wet & Liquid flammable		A85	I	E0	FORBIDDEN		480	1 L
Alkaloid salts, liquid, n.o.s.*	3140	6.1		Toxic		A3 A4 A6	I II III	E5 E4 E1	652 654 Y641 655 Y642	1 L 5 L 1 L 60 L 2 L	658 662 663	30 L 60 L 220 L
Alkaloid salts, solid, n.o.s.*	1544	6.1		Toxic		A3 A5 A6	I II III	E5 E4 E1	666 669 Y644 670 Y645	5 kg 25 kg 1 kg 100 kg 10 kg	673 676 677	50 kg 100 kg 200 kg
Alkaloids, liquid, n.o.s.*	3140	6.1		Toxic		A3 A4 A6	I II III	E5 E4 E1	652 654 Y641 655 Y642	1 L 5 L 1 L 60 L 2 L	658 662 663	30 L 60 L 220 L
Alkaloids, solid, n.o.s.*	1544	6.1		Toxic		A3 A5 A6	I II III	E5 E4 E1	666 669 Y644 670 Y645	5 kg 25 kg 1 kg 100 kg 10 kg	673 676 677	50 kg 100 kg 200 kg
Alkyl aluminium halides, see Organometallic substance, solid, pyrophoric, water-reactive (UN No. 3393) or Organometallic substance, liquid, pyrophoric, water-reactive (UN No. 3394)												
Alkylphenols, liquid, n.o.s. (including C ₂ -C ₁₂ homologues)	3145	8		Corrosive		A3	I II III	E0 E2 E1	850 851 Y840 852 Y841	0.5 L 1 L 0.5 L 5 L 1 L	854 855 856	2.5 L 30 L 60 L
Alkylphenols, solid, n.o.s. (including C ₂ -C ₁₂ homologues)	2430	8		Corrosive		A3	I II III	E0 E2 E1	858 859 Y843 860 Y845	1 kg 15 kg 1 kg 25 kg 5 kg	862 863 864	25 kg 50 kg 100 kg
Alkylsulphonic acids, liquid with more than 5% free sulphuric acid	2584	8		Corrosive			II	E2	851 Y840	1 L 0.5 L	855	30 L
Alkylsulphonic acids, liquid with not more than 5% free sulphuric acid	2586	8		Corrosive			III	E1	852 Y841	5 L 1 L	856	60 L
Alkylsulphonic acids, solid with more than 5% free sulphuric acid	2583	8		Corrosive			II	E2	859 Y844	15 kg 5 kg	863	50 kg

Name	UN No.	Class or division	Subsidiary risk	Labels	State variations	Special provisions	UN packing group	Excepted quantity	Passenger and cargo aircraft		Cargo aircraft only	
									Packing instruction	Max. net quantity per package	Packing instruction	Max. net quantity per package
1	2	3	4	5	6	7	8	9	10	11	12	13
Alkylsulphonic acids, solid with not more than 5% free sulphuric acid	2585	8		Corrosive			III	E1	860 Y845	25 kg 5 kg	864	100 kg
Alkylsulphuric acids	2571	8		Corrosive			II	E2	851 Y840	1 L 0.5 L	855	30 L
Allene, see Propadiene, stabilized												
Allyl acetate	2333	3	6.1	Liquid flammable & Toxic			II	E2	352 Y341	1 L 1 L	364	60 L
Allyl alcohol	1098	6.1	3						FORBIDDEN		FORBIDDEN	
Allylamine	2334	6.1	3						FORBIDDEN		FORBIDDEN	
Allyl bromide	1099	3	6.1	Liquid flammable & Toxic			I	E0	FORBIDDEN		361	30 L
Allyl chloride	1100	3	6.1	Liquid flammable & Toxic			I	E0	FORBIDDEN		361	30 L
Allyl chlorocarbonate, see Allyl chloroformate												
Allyl chloroformate	1722	6.1	3 8						FORBIDDEN		FORBIDDEN	
Allyl ethyl ether	2335	3	6.1	Liquid flammable & Toxic			II	E2	352 Y341	1 L 1 L	364	60 L
Allyl formate	2336	3	6.1	Liquid flammable & Toxic			I	E0	FORBIDDEN		361	30 L
Allyl glycidyl ether	2219	3		Liquid flammable			III	E1	355 Y344	60 L 10 L	366	220 L
Allyl iodide	1723	3	8	Liquid flammable & Corrosive			II	E2	352 Y340	1 L 0.5 L	362	5 L
Allyl isothiocyanate, stabilized	1545	6.1	3	Toxic & Liquid flammable	AU 1 CA 7 IR 3 NL 1 US 3	A1	II	E0	FORBIDDEN		661	60 L
Allyltrichlorosilane, stabilized	1724	8	3	Corrosive & Liquid flammable	AU 1 CA 7 IR 3 NL 1 US 3	A1	II	E0	FORBIDDEN		876	30 L
Aluminium alkyl halides, liquid, see Organometallic substance, liquid, pyrophoric, water reactive (UN No. 3394)												

Name	UN No.	Class or division	Subsidiary risk	Labels	State variations	Special provisions	UN packing group	Excepted quantity	Passenger and cargo aircraft		Cargo aircraft only	
									Packing instruction	Max. net quantity per package	Packing instruction	Max. net quantity per package
1	2	3	4	5	6	7	8	9	10	11	12	13
Aluminium alkyl halides, solid, see Organometallic substance, solid, pyrophoric, water reactive (UN No. 3393)												
Aluminium alkyl hydrides, see Organometallic substance, liquid, pyrophoric, water-reactive (UN No. 3394)												
Aluminium alkyls, see Organometallic substance, liquid, pyrophoric, water-reactive (UN No. 3394)												
Aluminium borohydride	2870	4.2	4.3						FORBIDDEN		FORBIDDEN	
Aluminium borohydride in devices	2870	4.2	4.3						FORBIDDEN		FORBIDDEN	
Aluminium bromide, anhydrous	1725	8		Corrosive			II	E2	859 Y844	15 kg 5 kg	863	50 kg
Aluminium bromide solution	2580	8		Corrosive		A3	III	E1	852 Y841	5 L 1 L	856	60 L
Aluminium carbide	1394	4.3		Danger if wet			II	E2	484 Y475	15 kg 5 kg	489	50 kg
Aluminium chloride, anhydrous	1726	8		Corrosive			II	E2	859 Y844	15 kg 5 kg	863	50 kg
Aluminium chloride solution	2581	8		Corrosive		A3	III	E1	852 Y841	5 L 1 L	856	60 L
Aluminium dross, see Aluminium remelting by-products or Aluminium smelting by-products												
Aluminium dross, wet or hot	FORBIDDEN											
Aluminium ferrosilicon powder	1395	4.3	6.1	Danger if wet & Toxic			II	E2	483 Y474	15 kg 1 kg	490	50 kg
Aluminium hydride	2463	4.3		Danger if wet			I	E0	FORBIDDEN		487	15 kg
Aluminium nitrate	1438	5.1		Oxidizer			III	E1	559 Y546	25 kg 10 kg	563	100 kg
Aluminium phosphide	1397	4.3	6.1	Danger if wet & Toxic			I	E0	FORBIDDEN		487	15 kg
Aluminium phosphide pesticide	3048	6.1				A128		E0	FORBIDDEN		FORBIDDEN	
Aluminium powder, coated †	1309	4.1		Solid flammable		A3	II	E2	445 Y441	15 kg 5 kg	448	50 kg
							III	E1	446 Y443	25 kg 10 kg	449	100 kg

Name	UN No.	Class or division	Subsidiary risk	Labels	State variations	Special provisions	UN packing group	Excepted quantity	Passenger and cargo aircraft		Cargo aircraft only		
									Packing instruction	Max. net quantity per package	Packing instruction	Max. net quantity per package	
1	2	3	4	5	6	7	8	9	10	11	12	13	
Aluminium powder, uncoated †	1396	4.3		Danger if wet		A3	II	E2	484	15 kg	490	50 kg	
									Y475	5 kg		491	100 kg
									486	25 kg			
Y477	10 kg												
Aluminium remelting by-products	3170	4.3		Danger if wet		A3 A102	II	E2	484	15 kg	490	50 kg	
									Y475	5 kg		491	100 kg
									486	25 kg			
Y477	10 kg												
Aluminium resinate	2715	4.1		Solid flammable			III	E1	446	25 kg	449	100 kg	
									Y443	10 kg			
Aluminium silicon powder, uncoated	1398	4.3		Danger if wet		A3 A53	III	E1	486	25 kg	491	100 kg	
									Y477	10 kg			
Aluminium smelting by-products	3170	4.3		Danger if wet		A3 A102	II	E2	484	15 kg	490	50 kg	
									Y475	5 kg		491	100 kg
									486	25 kg			
Y477	10 kg												
Amatols, see Explosive, blasting, type B													
Amines, flammable, corrosive, n.o.s.*	2733	3	8	Liquid flammable & Corrosive		A3	I	E0	350	0.5 L	360	2.5 L	
										1 L		363	5 L
									Y340	0.5 L			
							III	E1	354	5 L	365	60 L	
									Y342	1 L			
Amines, liquid, corrosive, n.o.s.*	2735	8		Corrosive		A3	I	E0	850	0.5 L	854	2.5 L	
										1 L		855	30 L
									Y840	0.5 L			
										5 L		856	60 L
	1 L												
Amines, liquid, corrosive, flammable, n.o.s.*	2734	8	3	Corrosive & Liquid flammable			I	E0	850	0.5 L	854	2.5 L	
										1 L		855	30 L
									Y840	0.5 L			
Amines, solid, corrosive, n.o.s.*	3259	8		Corrosive		A3	I	E0	858	1 kg	862	25 kg	
										15 kg		863	50 kg
									Y844	5 kg			
										25 kg		864	100 kg
										5 kg			
Aminobenzene, see Aniline													
2-Aminobenzotrifluoride, see 2-Trifluoromethylaniline													
3-Aminobenzotrifluoride, see 3-Trifluoromethylaniline													

Name	UN No.	Class or division	Subsidiary risk	Labels	State variations	Special provisions	UN packing group	Excepted quantity	Passenger and cargo aircraft		Cargo aircraft only	
									Packing instruction	Max. net quantity per package	Packing instruction	Max. net quantity per package
1	2	3	4	5	6	7	8	9	10	11	12	13
Aminobutane, see n-Butylamine												
2-Amino-4-chlorophenol	2673	6.1		Toxic			II	E4	669 Y644	25 kg 1 kg	676	100 kg
2-Amino-5-diethylaminopentane	2946	6.1		Toxic			III	E1	655 Y642	60 L 2 L	663	220 L
2-Amino-4,6-dinitrophenol, wetted with not less than 20% water by mass	3317	4.1		Solid flammable	BE 3	A40	I	E0	451	1 kg	451	15 kg
2-(2-Aminoethoxy)ethanol	3055	8		Corrosive			III	E1	852 Y841	5 L 1 L	856	60 L
N-Aminoethylpiperazine	2815	8		Corrosive			III	E1	852 Y841	5 L 1 L	856	60 L
1-Amino-2-nitrobenzene, see Nitroanilines												
1-Amino-3-nitrobenzene, see Nitroanilines												
1-Amino-4-nitrobenzene, see Nitroanilines												
Aminophenols (o-,m-,p-)	2512	6.1		Toxic		A113	III	E1	670 Y645	100 kg 10 kg	677	200 kg
Aminopyridines (o-,m-,p-)	2671	6.1		Toxic			II	E4	669 Y644	25 kg 1 kg	676	100 kg
Ammonia, anhydrous	1005	2.3	8		AU 1 CA 7 IR 3 NL 1 US 3	A2			FORBIDDEN		FORBIDDEN	
Ammonia solution , relative density between 0.880 and 0.957 at 15°C in water, with more than 10% but not more than 35% ammonia	2672	8		Corrosive		A64	III	E1	852 Y841	5 L 1 L	856	60 L
Ammonia solution , relative density less than 0.880 at 15°C in water, with more than 50% ammonia	3318	2.3	8		AU 1 CA 7 IR 3 NL 1 US 3	A2			FORBIDDEN		FORBIDDEN	
Ammonia solution , relative density less than 0.880 at 15°C in water, with more than 35% but not more than 50% ammonia	2073	2.2		Gas non-flammable	AU 1 CA 7 IR 3 NL 1 US 3	A1		E0	FORBIDDEN		200	150 kg

Name	UN No.	Class or division	Subsidiary risk	Labels	State variations	Special provisions	UN packing group	Excepted quantity	Passenger and cargo aircraft		Cargo aircraft only	
									Packing instruction	Max. net quantity per package	Packing instruction	Max. net quantity per package
1	2	3	4	5	6	7	8	9	10	11	12	13
Ammonium arsenate	1546	6.1		Toxic			II	E4	669 Y644	25 kg 1 kg	676	100 kg
Ammonium azide	FORBIDDEN											
Ammonium bichromate, see Ammonium dichromate												
Ammonium bifluoride, solid, see Ammonium hydrogendifluoride, solid												
Ammonium bifluoride solution, see Ammonium hydrogendifluoride, solution												
Ammonium bisulphate, see Ammonium hydrogen sulphate												
Ammonium bisulphite solution, see Bisulphites, aqueous solution, n.o.s.												
Ammonium bromate	FORBIDDEN											
Ammonium chlorate	FORBIDDEN											
Ammonium dichromate	1439	5.1		Oxidizer	US 4		II	E2	558 Y544	5 kg 2.5 kg	562	25 kg
Ammonium dinitro-o-cresolate, solid	1843	6.1		Toxic			II	E4	669 Y644	25 kg 1 kg	676	100 kg
Ammonium dinitro-o-cresolate solution	3424	6.1		Toxic		A3	II	E4	654 Y641	5 L 1 L	662	60 L
							III	E1	655 Y642	60 L 2 L	663	220 L
Ammonium fluoride	2505	6.1		Toxic	US 4		III	E1	670 Y645	100 kg 10 kg	677	200 kg
Ammonium fluorosilicate	2854	6.1		Toxic			III	E1	670 Y645	100 kg 10 kg	677	200 kg
Ammonium fulminate	FORBIDDEN											
Ammonium hexafluorosilicate, see Ammonium fluorosilicate												
Ammonium hydrogendifluoride, solid	1727	8		Corrosive	US 4		II	E2	859 Y844	15 kg 5 kg	863	50 kg

Name	UN No.	Class or division	Subsidiary risk	Labels	State variations	Special provisions	UN packing group	Excepted quantity	Passenger and cargo aircraft		Cargo aircraft only	
									Packing instruction	Max. net quantity per package	Packing instruction	Max. net quantity per package
1	2	3	4	5	6	7	8	9	10	11	12	13
Ammonium hydrogendifluoride solution	2817	8	6.1	Corrosive & Toxic		A3	II	E2	851 Y840	1 L 0.5 L	855	30 L
							III	E1	852 Y841	5 L 1 L	856	60 L
Ammonium hydrogen sulphate	2506	8		Corrosive			II	E2	859 Y844	15 kg 5 kg	863	50 kg
Ammonium hydrosulphide solution, see Ammonium sulphide solution												
Ammonium metavanadate	2859	6.1		Toxic			II	E4	669 Y644	25 kg 1 kg	676	100 kg
≠ Ammonium nitrate	0222	1.1D							FORBIDDEN		FORBIDDEN	
Ammonium nitrate with not more than 0.2% combustible substances, including any organic substance calculated as carbon, to the exclusion of any other added substance	1942	5.1		Oxidizer		A64	III	E1	559 Y546	25 kg 10 kg	563	100 kg
Ammonium nitrate based fertilizer	2067	5.1		Oxidizer		A64 A79 A89	III	E1	559 Y546	25 kg 10 kg	563	100 kg
Ammonium nitrate based fertilizer	2071	9		Miscellaneous		A89 A90	III	E1	958 Y958	200 kg 30 kg G	958	200 kg
Ammonium nitrate emulsion intermediate for blasting explosives	3375	5.1							FORBIDDEN		FORBIDDEN	
Ammonium nitrate explosives, see Explosive, blasting, type B												
Ammonium nitrate gel intermediate for blasting explosives	3375	5.1							FORBIDDEN		FORBIDDEN	
Ammonium nitrate, liquid (hot concentrated solution)	2426	5.1				A129			FORBIDDEN		FORBIDDEN	
Ammonium nitrate suspension intermediate for blasting explosives	3375	5.1							FORBIDDEN		FORBIDDEN	
Ammonium nitrite									FORBIDDEN		FORBIDDEN	
Ammonium perchlorate	0402	1.1D				A22			FORBIDDEN		FORBIDDEN	
Ammonium perchlorate	1442	5.1		Oxidizer		A22	II	E2	558 Y544	5 kg 2.5 kg	562	25 kg
Ammonium permanganate									FORBIDDEN		FORBIDDEN	
Ammonium persulphate	1444	5.1		Oxidizer			III	E1	559 Y546	25 kg 10 kg	563	100 kg

Name	UN No.	Class or division	Subsidiary risk	Labels	State variations	Special provisions	UN packing group	Excepted quantity	Passenger and cargo aircraft		Cargo aircraft only	
									Packing instruction	Max. net quantity per package	Packing instruction	Max. net quantity per package
1	2	3	4	5	6	7	8	9	10	11	12	13
Ammonium picrate dry or wetted with less than 10% water, by mass	0004	1.1D							FORBIDDEN		FORBIDDEN	
Ammonium picrate, wetted with not less than 10% water, by mass	1310	4.1		Solid flammable	BE 3	A40	I	E0	451	0.5 kg	451	0.5 kg
Ammonium polysulphide solution	2818	8	6.1	Corrosive & Toxic		A3	II	E2	851 Y840	1 L 0.5 L	855	30 L
							III	E1	852 Y841	5 L 1 L	856	60 L
Ammonium polyvanadate	2861	6.1		Toxic			II	E4	669 Y644	25 kg 1 kg	676	100 kg
Ammonium silicofluoride, see Ammonium fluorosilicate												
Ammonium sulphide solution	2683	8	3 6.1	Corrosive & Liquid flammable & Toxic			II	E2	851 Y840	1 L 0.5 L	855	30 L
Ammunition, blank, see Cartridges for weapons, blank												
Ammunition, fixed, semi-fixed or separate loading, see Cartridges for weapons , etc.												
Ammunition, illuminating with or without burster, expelling charge or propelling charge †	0171	1.2G							FORBIDDEN		FORBIDDEN	
Ammunition, illuminating with or without burster, expelling charge or propelling charge †	0254	1.3G							FORBIDDEN		FORBIDDEN	
Ammunition, illuminating with or without burster, expelling charge or propelling charge †	0297	1.4G		Explosive 1.4				E0	FORBIDDEN		130	75 kg
Ammunition, incendiary , liquid or gel, with burster, expelling charge or propelling charge †	0247	1.3J							FORBIDDEN		FORBIDDEN	
Ammunition, incendiary with or without burster, expelling charge or propelling charge †	0009	1.2G							FORBIDDEN		FORBIDDEN	
Ammunition, incendiary with or without burster, expelling charge or propelling charge †	0010	1.3G							FORBIDDEN		FORBIDDEN	
Ammunition, incendiary with or without burster, expelling charge or propelling charge †	0300	1.4G		Explosive 1.4				E0	FORBIDDEN		130	75 kg

Name	UN No.	Class or division	Subsidiary risk	Labels	State variations	Special provisions	UN packing group	Excepted quantity	Passenger and cargo aircraft		Cargo aircraft only	
									Packing instruction	Max. net quantity per package	Packing instruction	Max. net quantity per package
1	2	3	4	5	6	7	8	9	10	11	12	13
Ammunition, incendiary (water-activated contrivances), see Contrivances, water-activated , etc. (UN Nos. 0248, 0249)												
Ammunition, incendiary, white phosphorus with burster, expelling charge or propelling charge †	0243	1.2H							FORBIDDEN		FORBIDDEN	
Ammunition, incendiary, white phosphorus with burster, expelling charge or propelling charge †	0244	1.3H							FORBIDDEN		FORBIDDEN	
Ammunition, industrial, see Cartridges, oil well or Cartridges, power device												
Ammunition, lachrymatory, see Ammunition, tear-producing , etc.												
Ammunition, practice †	0362	1.4G		Explosive 1.4				E0	FORBIDDEN		130	75 kg
Ammunition, practice †	0488	1.3G							FORBIDDEN		FORBIDDEN	
Ammunition, proof †	0363	1.4G		Explosive 1.4				E0	FORBIDDEN		130	75 kg
Ammunition, smoke with or without burster, expelling charge or propelling charge †	0015	1.2G				A132			FORBIDDEN		FORBIDDEN	
Ammunition, smoke with or without burster, expelling charge or propelling charge †	0016	1.3G				A132			FORBIDDEN		FORBIDDEN	
Ammunition, smoke with or without burster, expelling charge or propelling charge †	0303	1.4G		Explosive 1.4		A132		E0	FORBIDDEN		130	75 kg
Ammunition, smoke (water-activated contrivances), white phosphorus, with burster, expelling charge or propelling charge, see Contrivances, water-activated , etc. (UN No. 0248)												
Ammunition, smoke (water-activated contrivances), without white phosphorus or phosphides, with burster, expelling charge or propelling charge, see Contrivances, water-activated , etc. (UN No. 0249)												
Ammunition, smoke, white phosphorus with burster, expelling charge or propelling charge †	0245	1.2H							FORBIDDEN		FORBIDDEN	

Name	UN No.	Class or division	Subsidiary risk	Labels	State variations	Special provisions	UN packing group	Excepted quantity	Passenger and cargo aircraft		Cargo aircraft only	
									Packing instruction	Max. net quantity per package	Packing instruction	Max. net quantity per package
1	2	3	4	5	6	7	8	9	10	11	12	13
Ammunition, smoke, white phosphorus with burster, expelling charge or propelling charge † Ammunition, sporting, see Cartridges for weapons, inert projectile or cartridges, small arms (UN Nos. 0012, 0328, 0339, 0417)	0246	1.3H							FORBIDDEN		FORBIDDEN	
Ammunition, tear-producing with burster, expelling charge or propelling charge †	0018	1.2G	6.1 8						FORBIDDEN		FORBIDDEN	
Ammunition, tear-producing with burster, expelling charge or propelling charge †	0019	1.3G	6.1 8						FORBIDDEN		FORBIDDEN	
Ammunition, tear-producing with burster, expelling charge or propelling charge †	0301	1.4G	6.1 8	Explosive 1.4 & Toxic & Corrosive				E0	FORBIDDEN		130	75 kg
≠ Ammunition, tear-producing, non-explosive without burster or expelling charge, non-fuzed	2017	6.1	8	Toxic & Corrosive	AU 1 CA 7 IR 3 NL 1 US 3	A1		E0	FORBIDDEN		679	50 kg
Ammunition, toxic* with burster, expelling charge or propelling charge †	0020	1.2K	6.1						FORBIDDEN		FORBIDDEN	
Ammunition, toxic* with burster, expelling charge or propelling charge †	0021	1.3K	6.1						FORBIDDEN		FORBIDDEN	
≠ Ammunition, toxic, non-explosive without burster or expelling charge, non-fuzed Ammunition, toxic (water-activated contrivances), see Contrivances, water-activated , etc. (UN Nos. 0248, 0249) Amorces, (caps, toy), see Fireworks (UN Nos. 0333, 0336, 0337)	2016	6.1		Toxic	AU 1 CA 7 IR 3 NL 1 US 3	A1		E0	FORBIDDEN		679	75 kg
≠ Amosite , see Asbestos, amphibole (UN No. 2212)												

Name	UN No.	Class or division	Subsidiary risk	Labels	State variations	Special provisions	UN packing group	Excepted quantity	Passenger and cargo aircraft		Cargo aircraft only	
									Packing instruction	Max. net quantity per package	Packing instruction	Max. net quantity per package
1	2	3	4	5	6	7	8	9	10	11	12	13
+ Amphibole asbestos, see Asbestos, amphibole (UN No. 2212)												
Amyl acetates	1104	3		Liquid flammable			III	E1	355 Y344	60 L 10 L	366	220 L
Amyl acid phosphate	2819	8		Corrosive			III	E1	852 Y841	5 L 1 L	856	60 L
Amyl aldehyde, see Valeraldehyde												
Amylamine	1106	3	8	Liquid flammable & Corrosive		A3	II	E2	352 Y340	1 L 0.5 L	363	5 L
							III	E1	354 Y342	5 L 1 L	365	60 L
Amyl butyrates	2620	3		Liquid flammable			III	E1	355 Y344	60 L 10 L	366	220 L
Amyl chloride	1107	3		Liquid flammable			II	E2	353 Y341	5 L 1 L	364	60 L
n-Amylene	1108	3		Liquid flammable			I	E3	351	1 L	361	30 L
Amyl formates	1109	3		Liquid flammable			III	E1	355 Y344	60 L 10 L	366	220 L
Amyl mercaptan	1111	3		Liquid flammable			II	E2	353 Y341	5 L 1 L	364	60 L
n-Amyl methyl ketone	1110	3		Liquid flammable			III	E1	355 Y344	60 L 10 L	366	220 L
Amyl nitrate	1112	3		Liquid flammable			III	E1	355 Y344	60 L 10 L	366	220 L
Amyl nitrite	1113	3		Liquid flammable			II	E2	353 Y341	5 L 1 L	364	60 L
tert-Amylperoxy-3,5,5-trimethylhexanoate	FORBIDDEN											
Amyltrichlorosilane	1728	8		Corrosive	AU 1 CA 7 IR 3 NL 1 US 3	A1	II	E0	FORBIDDEN		876	30 L
Anaesthetic ether, see Diethyl ether												
Aniline	1547	6.1		Toxic		A113	II	E4	654 Y641	5 L 1 L	662	60 L
Aniline chloride, see Aniline hydrochloride												
Aniline hydrochloride	1548	6.1		Toxic			III	E1	670 Y645	100 kg 10 kg	677	200 kg

Name	UN No.	Class or division	Subsidiary risk	Labels	State variations	Special provisions	UN packing group	Excepted quantity	Passenger and cargo aircraft		Cargo aircraft only	
									Packing instruction	Max. net quantity per package	Packing instruction	Max. net quantity per package
1	2	3	4	5	6	7	8	9	10	11	12	13
Aniline oil, see Aniline												
Aniline salt, see Aniline hydrochloride												
Anisidines	2431	6.1		Toxic			III	E1	655 Y642	60 L 2 L	663	220 L
Anisole	2222	3		Liquid flammable			III	E1	355 Y344	60 L 10 L	366	220 L
Anisoyl chloride	1729	8		Corrosive			II	E2	851 Y840	1 L 0.5 L	855	30 L
≠ Anthophyllite, see Asbestos, amphibole (UN No. 2212)												
Antimonious chloride, see Antimony trichloride												
Antimony compound, inorganic, liquid, n.o.s.*	3141	6.1		Toxic		A12	III	E1	655 Y642	60 L 2 L	663	220 L
Antimony compound, inorganic, solid, n.o.s.*	1549	6.1		Toxic		A12	III	E1	670 Y645	100 kg 10 kg	677	200 kg
Antimony hydride, see Stibine												
Antimony lactate	1550	6.1		Toxic			III	E1	670 Y645	100 kg 10 kg	677	200 kg
Antimony (III) lactate, see Antimony lactate												
Antimony pentachloride, liquid	1730	8		Corrosive			II	E2	851 Y840	1 L 0.5 L	855	30 L
Antimony pentachloride solution	1731	8		Corrosive		A3	II	E2	851 Y840	1 L 0.5 L	855	30 L
							III	E1	852 Y841	5 L 1 L	856	60 L
Antimony pentafluoride	1732	8	6.1	Corrosive & Toxic	AU 1 CA 7 IR 3 NL 1 US 3	A1	II	E0	FORBIDDEN		855	30 L
Antimony perchloride, liquid, see Antimony pentachloride, liquid												
Antimony potassium tartrate	1551	6.1		Toxic	US 4		III	E1	670 Y645	100 kg 10 kg	677	200 kg
Antimony powder	2871	6.1		Toxic			III	E1	670 Y645	100 kg 10 kg	677	200 kg

Name	UN No.	Class or division	Subsidiary risk	Labels	State variations	Special provisions	UN packing group	Excepted quantity	Passenger and cargo aircraft		Cargo aircraft only	
									Packing instruction	Max. net quantity per package	Packing instruction	Max. net quantity per package
1	2	3	4	5	6	7	8	9	10	11	12	13
Antimony sulphide and a chlorate, mixture of	FORBIDDEN											
Antimony trichloride	1733	8		Corrosive			II	E2	859 Y844	15 kg 5 kg	863	50 kg
Antu, see Naphthylthiourea												
Argon, compressed	1006	2.2		Gas non-flammable		A69		E1	200	75 kg	200	150 kg
Argon, refrigerated liquid	1951	2.2		Gas non-flammable				E1	202	50 kg	202	500 kg
Arsenates, n.o.s., see Arsenic compound, liquid, n.o.s. or Arsenic compound, solid, n.o.s.												
Arsenic	1558	6.1		Toxic	US 4		II	E4	669 Y644	25 kg 1 kg	676	100 kg
Arsenic acid, liquid	1553	6.1		Toxic	US 4		I	E5	652	1 L	658	30 L
Arsenic acid, solid	1554	6.1		Toxic	US 4		II	E4	669 Y644	25 kg 1 kg	676	100 kg
Arsenical dust †	1562	6.1		Toxic			II	E4	669 Y644	25 kg 1 kg	676	100 kg
Arsenical flue dust, see Arsenical dust												
Arsenical pesticide, liquid, flammable, toxic* , flash point less than 23°C	2760	3	6.1	Liquid flammable & Toxic		A4	I II	E0 E2	FORBIDDEN 352 Y341	1 L 1 L	361 364	30 L 60 L
Arsenical pesticide, liquid, toxic*	2994	6.1		Toxic		A3 A4	I II III	E5 E4 E1	652 654 Y641 655 Y642	1 L 5 L 1 L 60 L 2 L	658 662 663	30 L 60 L 220 L
Arsenical pesticide, liquid, toxic, flammable* , flash point not less than 23°C	2993	6.1	3	Toxic & Liquid flammable		A3 A4	I II III	E5 E4 E1	652 654 Y641 655 Y642	1 L 5 L 1 L 60 L 2 L	658 662 663	30 L 60 L 220 L
Arsenical pesticide, solid, toxic*	2759	6.1		Toxic		A3 A5	I II III	E5 E4 E1	666 669 Y644 670 Y645	5 kg 25 kg 1 kg 100 kg 10 kg	673 676 677	50 kg 100 kg 200 kg
Arsenic bromide	1555	6.1		Toxic			II	E4	669 Y644	25 kg 1 kg	676	100 kg

Name	UN No.	Class or division	Subsidiary risk	Labels	State variations	Special provisions	UN packing group	Excepted quantity	Passenger and cargo aircraft		Cargo aircraft only	
									Packing instruction	Max. net quantity per package	Packing instruction	Max. net quantity per package
1	2	3	4	5	6	7	8	9	10	11	12	13
Arsenic (III) bromide, see Arsenic bromide												
Arsenic chloride, see Arsenic trichloride												
Arsenic compound, liquid, n.o.s.* , inorganic, including: Arsenates, n.o.s.; Arsenites, n.o.s.; and Arsenic sulphides	1556	6.1		Toxic		A3 A4 A6	I II III	E5 E4 E1	652 654 Y641 655 Y642	1 L 5 L 1 L 60 L 2 L	658 662 663	30 L 60 L 220 L
Arsenic compound, solid, n.o.s.* , inorganic, including: Arsenates, n.o.s.; Arsenites, n.o.s.; and Arsenic sulphides	1557	6.1		Toxic	US 4	A3 A5 A6	I II III	E5 E4 E1	666 669 Y644 670 Y645	5 kg 25 kg 1 kg 100 kg 10 kg	673 676 677	50 kg 100 kg 200 kg
Arsenic (III) oxide, see Arsenic trioxide												
Arsenic (V) oxide, see Arsenic pentoxide												
Arsenic pentoxide	1559	6.1		Toxic	US 4		II	E4	669 Y644	25 kg 1 kg	676	100 kg
Arsenic sulphide and a chlorate, mixture of	FORBIDDEN											
Arsenic sulphides, see Arsenic compound, liquid, n.o.s. or Arsenic compound, solid, n.o.s.												
Arsenic trichloride	1560	6.1			US 4				FORBIDDEN		FORBIDDEN	
Arsenic trioxide	1561	6.1		Toxic	US 4		II	E4	669 Y644	25 kg 1 kg	676	100 kg
Arsenious chloride, see Arsenic trichloride												
Arsenites, n.o.s., see Arsenic compound, liquid, n.o.s. or Arsenic compound, solid, n.o.s.												
Arsenous chloride, see Arsenic trichloride												

Name	UN No.	Class or division	Subsidiary risk	Labels	State variations	Special provisions	UN packing group	Excepted quantity	Passenger and cargo aircraft		Cargo aircraft only	
									Packing instruction	Max. net quantity per package	Packing instruction	Max. net quantity per package
1	2	3	4	5	6	7	8	9	10	11	12	13
Arsine	2188	2.3	2.1		AU 1 CA 7 IR 3 NL 1 US 3	A2			FORBIDDEN		FORBIDDEN	
+ Arsine, adsorbed	3522	2.3	2.1			A2		E0	FORBIDDEN		FORBIDDEN	
Articles, EEI †	0486	1.6N				A62			FORBIDDEN		FORBIDDEN	
Articles, explosive, n.o.s.*	0349	1.4S		Explosive 1.4		A62		E0	101	25 kg	101	100 kg
Articles, explosive, n.o.s.*	0350	1.4B				A62			FORBIDDEN		FORBIDDEN	
Articles, explosive, n.o.s.*	0351	1.4C		Explosive 1.4		A62		E0	FORBIDDEN		101	75 kg
Articles, explosive, n.o.s.*	0352	1.4D		Explosive 1.4		A62		E0	FORBIDDEN		101	75 kg
Articles, explosive, n.o.s.*	0353	1.4G		Explosive 1.4		A62		E0	FORBIDDEN		101	75 kg
Articles, explosive, n.o.s.*	0354	1.1L				A62			FORBIDDEN		FORBIDDEN	
Articles, explosive, n.o.s.*	0355	1.2L				A62			FORBIDDEN		FORBIDDEN	
Articles, explosive, n.o.s.*	0356	1.3L				A62			FORBIDDEN		FORBIDDEN	
Articles, explosive, n.o.s.*	0462	1.1C				A62			FORBIDDEN		FORBIDDEN	
Articles, explosive, n.o.s.*	0463	1.1D				A62			FORBIDDEN		FORBIDDEN	
Articles, explosive, n.o.s.*	0464	1.1E				A62			FORBIDDEN		FORBIDDEN	
Articles, explosive, n.o.s.*	0465	1.1F				A62			FORBIDDEN		FORBIDDEN	
Articles, explosive, n.o.s.*	0466	1.2C				A62			FORBIDDEN		FORBIDDEN	
Articles, explosive, n.o.s.*	0467	1.2D				A62			FORBIDDEN		FORBIDDEN	
Articles, explosive, n.o.s.*	0468	1.2E				A62			FORBIDDEN		FORBIDDEN	
Articles, explosive, n.o.s.*	0469	1.2F				A62			FORBIDDEN		FORBIDDEN	
Articles, explosive, n.o.s.*	0470	1.3C				A62			FORBIDDEN		FORBIDDEN	
Articles, explosive, n.o.s.*	0471	1.4E		Explosive 1.4		A62		E0	FORBIDDEN		101	75 kg
Articles, explosive, n.o.s.*	0472	1.4F				A62			FORBIDDEN		FORBIDDEN	
Articles, explosive, extremely insensitive †	0486	1.6N				A62			FORBIDDEN		FORBIDDEN	
≠ Articles, pressurized, hydraulic containing non-flammable gas	3164	2.2		Gas non-flammable		A48 A114 A195		E0	208	No limit	208	No limit
≠ Articles, pressurized, pneumatic containing non-flammable gas	3164	2.2		Gas non-flammable		A48 A114 A195		E0	208	No limit	208	No limit

Name	UN No.	Class or division	Subsidiary risk	Labels	State variations	Special provisions	UN packing group	Excepted quantity	Passenger and cargo aircraft		Cargo aircraft only	
									Packing instruction	Max. net quantity per package	Packing instruction	Max. net quantity per package
1	2	3	4	5	6	7	8	9	10	11	12	13
Articles, pyrophoric †	0380	1.2L							FORBIDDEN		FORBIDDEN	
Articles, pyrotechnic for technical purposes †	0428	1.1G							FORBIDDEN		FORBIDDEN	
Articles, pyrotechnic for technical purposes †	0429	1.2G							FORBIDDEN		FORBIDDEN	
Articles, pyrotechnic for technical purposes †	0430	1.3G							FORBIDDEN		FORBIDDEN	
Articles, pyrotechnic for technical purposes †	0431	1.4G		Explosive 1.4				E0	FORBIDDEN		135	75 kg
Articles, pyrotechnic for technical purposes †	0432	1.4S		Explosive 1.4				E0	135	25 kg	135	100 kg
Arylsulphonic acids, liquid with more than 5% free sulphuric acid	2584	8		Corrosive			II	E2	851 Y840	1 L 0.5 L	855	30 L
Arylsulphonic acids, liquid with not more than 5% free sulphuric acid	2586	8		Corrosive			III	E1	852 Y841	5 L 1 L	856	60 L
Arylsulphonic acids, solid with more than 5% free sulphuric acid	2583	8		Corrosive			II	E2	859 Y844	15 kg 5 kg	863	50 kg
Arylsulphonic acids, solid with not more than 5% free sulphuric acid	2585	8		Corrosive			III	E1	860 Y845	25 kg 5 kg	864	100 kg
≠ Asbestos †, see Asbestos, amphibole (UN No. 2212) or Asbestos, chrysotile (UN No. 2590)												
≠ Asbestos, amphibole* (amosite, tremolite, actinolite, anthophyllite, crocidolite)†	2212	9				A61			FORBIDDEN		FORBIDDEN	
≠ Asbestos, chrysotile †	2590	9		Miscellaneous	US 4	A61	III	E1	958	200 kg	958	200 kg
Ascaridole									FORBIDDEN			
Aviation regulated liquid, n.o.s.*	3334	9		Miscellaneous		A27	III	E1	964 Y964	450 L 30 kg G	964	450 L
Aviation regulated solid, n.o.s.*	3335	9		Miscellaneous		A27	III	E1	956 Y956	400 kg 30 kg G	956	400 kg
Azaurolic acid (salt of) (dry)									FORBIDDEN			
Azidodithiocarbonic acid									FORBIDDEN			
Azidoethyl nitrate									FORBIDDEN			
Azido guanidine picrate (dry)									FORBIDDEN			

Name	UN No.	Class or division	Subsidiary risk	Labels	State variations	Special provisions	UN packing group	Excepted quantity	Passenger and cargo aircraft		Cargo aircraft only	
									Packing instruction	Max. net quantity per package	Packing instruction	Max. net quantity per package
1	2	3	4	5	6	7	8	9	10	11	12	13
5-Azido-1-hydroxy tetrazole	FORBIDDEN											
Azido hydroxy tetrazole (mercury and silver salts)	FORBIDDEN											
3-Azido-1,2-propylene glycol dinitrate	FORBIDDEN											
Azodicarbonamide	3242	4.1				A60			FORBIDDEN		FORBIDDEN	
Azodicarbonamide formulation type B, temperature controlled	FORBIDDEN											
Azotetrazole (dry)	FORBIDDEN											
B												
Bag charges, see Charges, propelling, for cannon												
Ballistite, see Powder, smokeless												
Bangalore torpedoes, see Mines with bursting charge (UN Nos. 0136, 0137, 0138, 0294)												
Barium	1400	4.3		Danger if wet			II	E2	484 Y475	15 kg 5 kg	490	50 kg
Barium alloys, pyrophoric	1854	4.2							FORBIDDEN		FORBIDDEN	
Barium azide , dry or wetted with less than 50% water, by mass	0224	1.1A	6.1						FORBIDDEN		FORBIDDEN	
Barium azide , wetted with not less than 50% water, by mass	1571	4.1	6.1	Solid flammable & Toxic	BE 3	A40	I	E0	FORBIDDEN		451	0.5 kg
Barium binoxide, see Barium peroxide												
Barium bromate	2719	5.1	6.1	Oxidizer & Toxic			II	E2	558 Y543	5 kg 1 kg	562	25 kg
Barium chlorate, solid	1445	5.1	6.1	Oxidizer & Toxic			II	E2	558 Y543	5 kg 1 kg	562	25 kg
Barium chlorate solution	3405	5.1	6.1	Oxidizer & Toxic		A3	II III	E2 E1	550 Y540 Y541	1 L 0.5 L 2.5 L 1 L	554 555	5 L 30 L

Name	UN No.	Class or division	Subsidiary risk	Labels	State variations	Special provisions	UN packing group	Excepted quantity	Passenger and cargo aircraft		Cargo aircraft only	
									Packing instruction	Max. net quantity per package	Packing instruction	Max. net quantity per package
1	2	3	4	5	6	7	8	9	10	11	12	13
Barium compound, n.o.s.*	1564	6.1		Toxic		A3 A82	II	E4	669 Y644	25 kg 1 kg	676	100 kg
							III	E1	670 Y645	100 kg 10 kg	677	200 kg
Barium cyanide	1565	6.1		Toxic	US 4		I	E5	666	5 kg	673	50 kg
Barium dioxide, see Barium peroxide												
Barium hypochlorite with more than 22% available chlorine	2741	5.1	6.1	Oxidizer & Toxic			II	E2	558 Y543	5 kg 1 kg	562	25 kg
Barium nitrate	1446	5.1	6.1	Oxidizer & Toxic			II	E2	558 Y543	5 kg 1 kg	562	25 kg
Barium oxide	1884	6.1		Toxic			III	E1	670 Y645	100 kg 10 kg	677	200 kg
Barium perchlorate, solid	1447	5.1	6.1	Oxidizer & Toxic			II	E2	558 Y543	5 kg 1 kg	562	25 kg
Barium perchlorate solution	3406	5.1	6.1	Oxidizer & Toxic		A3	II	E2	550 Y540	1 L 0.5 L	554	5 L
							III	E1	551 Y541	2.5 L 1 L	555	30 L
Barium permanganate	1448	5.1	6.1	Oxidizer & Toxic			II	E2	558 Y543	5 kg 1 kg	562	25 kg
Barium peroxide	1449	5.1	6.1	Oxidizer & Toxic			II	E2	558 Y543	5 kg 1 kg	562	25 kg
Barium selenate, see Selenates												
Barium selenite, see Selenites												
Barium superoxide, see Barium peroxide												
≠ Batteries, containing sodium †	3292	4.3		Danger if wet		A94 A183		E0	FORBIDDEN		492	No limit
Batteries, dry, containing potassium hydroxide solid, electric storage †	3028	8		Corrosive		A183 A184		E0	871	25 kg	871	230 kg
Batteries, electric storage, see Special Provision A123												
+ Batteries, nickel-metal hydride	3496	9		Miscellaneous		A199				See Part 3;3, A199		

Name	UN No.	Class or division	Subsidiary risk	Labels	State variations	Special provisions	UN packing group	Excepted quantity	Passenger and cargo aircraft		Cargo aircraft only	
									Packing instruction	Max. net quantity per package	Packing instruction	Max. net quantity per package
1	2	3	4	5	6	7	8	9	10	11	12	13
Batteries, wet, filled with acid, electric storage †	2794	8		Corrosive		A51 A164 A183		E0	870	30 kg	870	No limit
Batteries, wet, filled with alkali, electric storage †	2795	8		Corrosive		A51 A164 A183		E0	870	30 kg	870	No limit
Batteries, wet, non-spillable, electric storage	2800	8		Corrosive		A48 A67 A164 A183		E0	872	No limit	872	No limit
Battery fluid, acid	2796	8		Corrosive			II	E2	851 Y840	1 L 0.5 L	855	30 L
Battery fluid, alkali	2797	8		Corrosive			II	E2	851 Y840	1 L 0.5 L	855	30 L
Battery, lithium ion, see Lithium ion batteries, etc. (UN Nos. 3480, 3481)												
Battery, lithium metal, see Lithium metal batteries, etc. (UN Nos. 3090, 3091)												
Battery-powered equipment	3171	9		Miscellaneous		A21 A67 A87 A94 A164 A182		E0	952	No limit	952	No limit
Battery-powered vehicle	3171	9		Miscellaneous		A21 A67 A87 A94 A164		E0	952	No limit	952	No limit
Benzaldehyde	1990	9		Miscellaneous			III	E1	964 Y964	100 L 30 kg G	964	220 L
Benzene	1114	3		Liquid flammable	US 4		II	E2	353 Y341	5 L 1 L	364	60 L
Benzene diazonium chloride (dry)	FORBIDDEN											
Benzene diazonium nitrate (dry)	FORBIDDEN											
Benzenesulphonyl chloride	2225	8		Corrosive	US 4		III	E1	852 Y841	5 L 1 L	856	60 L
Benzenethiol, see Phenyl mercaptan												

Name	UN No.	Class or division	Subsidiary risk	Labels	State variations	Special provisions	UN packing group	Excepted quantity	Passenger and cargo aircraft		Cargo aircraft only	
									Packing instruction	Max. net quantity per package	Packing instruction	Max. net quantity per package
1	2	3	4	5	6	7	8	9	10	11	12	13
Benzene triozone	FORBIDDEN											
Benzidine	1885	6.1		Toxic	US 4		II	E4	669 Y644	25 kg 1 kg	676	100 kg
Benzol, see Benzene												
Benzolene, see Petroleum distillates, n.o.s.												
Benzonitrile	2224	6.1		Toxic			II	E4	654 Y641	5 L 1 L	662	60 L
Benzoquinone	2587	6.1		Toxic	US 4		II	E4	669 Y644	25 kg 1 kg	676	100 kg
Benzosulphochloride, see Benzenesulphonyl chloride												
Benzotrichloride	2226	8		Corrosive	US 4		II	E2	851 Y840	1 L 0.5 L	855	30 L
Benzotrifluoride	2338	3		Liquid flammable			II	E2	353 Y341	5 L 1 L	364	60 L
Benzoxidiazoles (dry)	FORBIDDEN											
Benzoyl azide	FORBIDDEN											
Benzoyl chloride	1736	8		Corrosive			II	E2	851 Y840	1 L 0.5 L	855	30 L
Benzyl bromide	1737	6.1	8	Toxic & Corrosive			II	E4	653	1 L	660	30 L
Benzyl chloride	1738	6.1	8	Toxic & Corrosive			II	E4	653	1 L	660	30 L
Benzyl chlorocarbonate, see Benzyl chloroformate												
Benzyl chloroformate	1739	8		Corrosive	AU 1 CA 7 IR 3 NL 1 US 3	A1	I	E0	FORBIDDEN		854	2.5 L
Benzyl cyanide, see Phenylacetonitrile, liquid												
Benzyl dimethylamine	2619	8	3	Corrosive & Liquid flammable			II	E2	851 Y840	1 L 0.5 L	855	30 L
Benzylidene chloride	1886	6.1		Toxic			II	E4	654 Y641	5 L 1 L	662	60 L

Name	UN No.	Class or division	Subsidiary risk	Labels	State variations	Special provisions	UN packing group	Excepted quantity	Passenger and cargo aircraft		Cargo aircraft only	
									Packing instruction	Max. net quantity per package	Packing instruction	Max. net quantity per package
1	2	3	4	5	6	7	8	9	10	11	12	13
Benzyl iodide	2653	6.1		Toxic			II	E4	654 Y641	5 L 1 L	662	60 L
Beryllium compound, n.o.s.*	1566	6.1		Toxic	US 4	A3	II	E4	669 Y644	25 kg 1 kg	676	100 kg
							III	E1	670 Y645	100 kg 10 kg	677	200 kg
Beryllium nitrate	2464	5.1	6.1	Oxidizer & Toxic	US 4		II	E2	558 Y543	5 kg 1 kg	562	25 kg
Beryllium powder	1567	6.1	4.1	Toxic & Solid flammable	US 4		II	E4	668 Y644	15 kg 1 kg	675	50 kg
Beverage extract (concentrate), see Corrosive liquid, acidic, inorganic, n.o.s.												
+ Bhusa	1327	4.1				A2 A198			FORBIDDEN		FORBIDDEN	
Bicyclo [2.2.1] hepta-2-5-diene, stabilized	2251	3		Liquid flammable			II	E2	353 Y341	5 L 1 L	364	60 L
Bifluorides, n.o.s., see Hydrogen difluorides, solid, n.o.s. (UN No. 1740)												
Biological substance, Category B	3373	6.2		None	GB 5			E0	See 650		See 650	
Biomedical waste, n.o.s.	3291	6.2		Infectious		A117	II	E0	622	No limit	622	No limit
Biphenyl triozone	FORBIDDEN											
Bipyridilium pesticide, liquid, flammable, toxic* , flash point less than 23°C	2782	3	6.1	Liquid flammable & Toxic		A4	I	E0	FORBIDDEN		361	30 L
							II	E2	352 Y341	1 L 1 L	364	60 L
Bipyridilium pesticide, liquid, toxic*	3016	6.1		Toxic		A3 A4	I	E5	652	1 L	658	30 L
							II	E4	654 Y641	5 L 1 L	662	60 L
							III	E1	655 Y642	60 L 2 L	663	220 L
Bipyridilium pesticide, liquid, toxic, flammable* , flash point not less than 23°C	3015	6.1	3	Toxic & Liquid flammable		A3 A4	I	E5	652	1 L	658	30 L
							II	E4	654 Y641	5 L 1 L	662	60 L
							III	E1	655 Y642	60 L 2 L	663	220 L

Name	UN No.	Class or division	Subsidiary risk	Labels	State variations	Special provisions	UN packing group	Excepted quantity	Passenger and cargo aircraft		Cargo aircraft only	
									Packing instruction	Max. net quantity per package	Packing instruction	Max. net quantity per package
1	2	3	4	5	6	7	8	9	10	11	12	13
Bipyridilium pesticide, solid, toxic*	2781	6.1		Toxic		A3 A5	I II	E5 E4	666	5 kg	673	50 kg
									669	25 kg	676	100 kg
									Y644	1 kg		
									670 Y645	100 kg 10 kg	677	200 kg
Bisulphates, aqueous solution	2837	8		Corrosive		A3	II III	E2 E1	851	1 L	855	30 L
									Y840	0.5 L		
									852 Y841	5 L 1 L	856	60 L
Bisulphites, aqueous solution, n.o.s.*	2693	8		Corrosive			III	E1	852 Y841	5 L 1 L	856	60 L
Black powder , granular or as a meal †	0027	1.1D							FORBIDDEN		FORBIDDEN	
Black powder, compressed †	0028	1.1D							FORBIDDEN		FORBIDDEN	
Black powder in pellets †	0028	1.1D							FORBIDDEN		FORBIDDEN	
Blasting cap assemblies, see Detonator assemblies, non-electric , for blasting												
Blasting caps, electric, see Detonators, electric , for blasting												
Blasting caps, non-electric, see Detonators, non-electric , for blasting												
Bleaching powder, see Calcium hypochlorite mixture, dry , etc.												
Bombs with bursting charge †	0033	1.1F							FORBIDDEN		FORBIDDEN	
Bombs with bursting charge †	0034	1.1D							FORBIDDEN		FORBIDDEN	
Bombs with bursting charge †	0035	1.2D							FORBIDDEN		FORBIDDEN	
Bombs with bursting charge †	0291	1.2F							FORBIDDEN		FORBIDDEN	
Bombs, illuminating, see Ammunition, illuminating , etc. (UN No. 0254)												
Bombs, photo-flash †	0037	1.1F							FORBIDDEN		FORBIDDEN	
Bombs, photo-flash †	0038	1.1D							FORBIDDEN		FORBIDDEN	
Bombs, photo-flash †	0039	1.2G							FORBIDDEN		FORBIDDEN	
Bombs, photo-flash †	0299	1.3G							FORBIDDEN		FORBIDDEN	

Name	UN No.	Class or division	Subsidiary risk	Labels	State variations	Special provisions	UN packing group	Excepted quantity	Passenger and cargo aircraft		Cargo aircraft only	
									Packing instruction	Max. net quantity per package	Packing instruction	Max. net quantity per package
1	2	3	4	5	6	7	8	9	10	11	12	13
Bombs, smoke, non-explosive with corrosive liquid, without initiating device	2028	8		Corrosive			II	E0	FORBIDDEN		866	50 kg
Bombs, target identification, see Ammunition, illuminating , etc.												
Bombs with flammable liquid with bursting charge †	0399	1.1J							FORBIDDEN		FORBIDDEN	
Bombs with flammable liquid with bursting charge †	0400	1.2J							FORBIDDEN		FORBIDDEN	
Boosters without detonator †	0042	1.1D							FORBIDDEN		FORBIDDEN	
Boosters without detonator †	0283	1.2D							FORBIDDEN		FORBIDDEN	
Boosters with detonator †	0225	1.1B							FORBIDDEN		FORBIDDEN	
Boosters with detonator †	0268	1.2B							FORBIDDEN		FORBIDDEN	
Borate and chlorate mixture, see Chlorate and borate mixture												
Borneol	1312	4.1		Solid flammable			III	E1	446 Y443	25 kg 10 kg	449	100 kg
Boron tribromide	2692	8			AU 1 CA 7 IR 3 NL 1 US 3	A2			FORBIDDEN		FORBIDDEN	
Boron trichloride	1741	2.3	8		AU 1 CA 7 IR 3 NL 1 US 3	A2			FORBIDDEN		FORBIDDEN	
Boron trifluoride	1008	2.3	8		AU 1 CA 7 IR 3 NL 1 US 3	A2 A190			FORBIDDEN		FORBIDDEN	
Boron trifluoride acetic acid complex, liquid	1742	8		Corrosive			II	E2	851 Y840	1 L 0.5 L	855	30 L
Boron trifluoride acetic acid complex, solid	3419	8		Corrosive			II	E2	859 Y844	15 kg 5 kg	863	50 kg
+ Boron trifluoride, adsorbed	3519	2.3	8			A2		E0	FORBIDDEN		FORBIDDEN	
Boron trifluoride diethyl etherate	2604	8	3	Corrosive & Liquid flammable			I	E0	850	0.5 L	854	2.5 L

Name	UN No.	Class or division	Subsidiary risk	Labels	State variations	Special provisions	UN packing group	Excepted quantity	Passenger and cargo aircraft		Cargo aircraft only	
									Packing instruction	Max. net quantity per package	Packing instruction	Max. net quantity per package
1	2	3	4	5	6	7	8	9	10	11	12	13
Boron trifluoride dihydrate	2851	8		Corrosive			II	E2	851 Y840	1 L 0.5 L	855	30 L
Boron trifluoride dimethyl etherate	2965	4.3	3 8	Danger if wet & Liquid flammable & Corrosive			I	E0	FORBIDDEN		480	1 L
Boron trifluoride propionic acid complex, liquid	1743	8		Corrosive			II	E2	851 Y840	1 L 0.5 L	855	30 L
Boron trifluoride propionic acid complex, solid	3420	8		Corrosive			II	E2	859 Y844	15 kg 5 kg	863	50 kg
Bromates, inorganic, n.o.s.*	1450	5.1		Oxidizer		A170	II	E2	558 Y544	5 kg 2.5 kg	562	25 kg
Bromates, inorganic, aqueous solution, n.o.s.*	3213	5.1		Oxidizer		A3 A170	II	E2	550 Y540	1 L 0.5 L	554	5 L
							III	E1	551 Y541	2.5 L 1 L	555	30 L
Bromine	1744	8	6.1		AU 1 CA 7 IR 3 NL 1 US 3	A2			FORBIDDEN		FORBIDDEN	FORBIDDEN
Bromine azide	FORBIDDEN											
Bromine chloride	2901	2.3	5.1 8		AU 1 CA 7 IR 3 NL 1 US 3	A2			FORBIDDEN		FORBIDDEN	FORBIDDEN
Bromine pentafluoride	1745	5.1	6.1 8		AU 1 CA 7 IR 3 NL 1 US 3	A2			FORBIDDEN		FORBIDDEN	FORBIDDEN
Bromine solution	1744	8	6.1		AU 1 CA 7 IR 3 NL 1 US 3	A2			FORBIDDEN		FORBIDDEN	FORBIDDEN
Bromine trifluoride	1746	5.1	6.1 8		AU 1 CA 7 IR 3 NL 1 US 3	A2			FORBIDDEN		FORBIDDEN	FORBIDDEN
Bromoacetic acid, solid	3425	8		Corrosive			II	E2	859 Y844	15 kg 5 kg	863	50 kg

Name	UN No.	Class or division	Subsidiary risk	Labels	State variations	Special provisions	UN packing group	Excepted quantity	Passenger and cargo aircraft		Cargo aircraft only	
									Packing instruction	Max. net quantity per package	Packing instruction	Max. net quantity per package
1	2	3	4	5	6	7	8	9	10	11	12	13
Bromoacetic acid solution	1938	8		Corrosive		A3	II	E2	851 Y840 852 Y841	1 L 0.5 L 5 L 1 L	855 856	30 L 60 L
Bromoacetone	1569	6.1	3		AU 1 CA 7 IR 3 NL 1 US 3	A2			FORBIDDEN		FORBIDDEN	
omega-Bromoacetone, see Phenacyl bromide												
Bromoacetyl bromide	2513	8		Corrosive			II	E2	851 Y840	1 L 0.5 L	855	30 L
Bromobenzene	2514	3		Liquid flammable			III	E1	355 Y344	60 L 10 L	366	220 L
Bromobenzyl cyanides, liquid	1694	6.1		Toxic	AU 1 CA 7 IR 3 NL 1 US 3	A1 A29	I	E0	FORBIDDEN		658	30 L
Bromobenzyl cyanides, solid	3449	6.1		Toxic		A29	I	E5	666	5 kg	673	50 kg
1-Bromobutane	1126	3		Liquid flammable			II	E2	353 Y341	5 L 1 L	364	60 L
2-Bromobutane	2339	3		Liquid flammable			II	E2	353 Y341	5 L 1 L	364	60 L
Bromochloromethane	1887	6.1		Toxic			III	E1	655 Y642	60 L 2 L	663	220 L
1-Bromo-3-chloropropane	2688	6.1		Toxic			III	E1	655 Y642	60 L 2 L	663	220 L
4-Bromo-1,2-dinitrobenzene	FORBIDDEN											
1-Bromo-2,3-epoxypropane, see Epibromohydrin												
Bromoethane, see Ethyl bromide												
2-Bromoethyl ethyl ether	2340	3		Liquid flammable			II	E2	353 Y341	5 L 1 L	364	60 L
Bromoform	2515	6.1		Toxic	US 4		III	E1	655 Y642	60 L 2 L	663	220 L
Bromomethane, see Methyl bromide												
1-Bromo-3-methylbutane	2341	3		Liquid flammable			III	E1	355 Y344	60 L 10 L	366	220 L

Name	UN No.	Class or division	Subsidiary risk	Labels	State variations	Special provisions	UN packing group	Excepted quantity	Passenger and cargo aircraft		Cargo aircraft only	
									Packing instruction	Max. net quantity per package	Packing instruction	Max. net quantity per package
1	2	3	4	5	6	7	8	9	10	11	12	13
Bromomethylpropanes	2342	3		Liquid flammable			II	E2	353 Y341	5 L 1 L	364	60 L
2-Bromo-2-nitropropane-1,3-diol	3241	4.1		Solid flammable		A20	III	E1	457 Y457	25 kg 10 kg	457	50 kg
2-Bromopentane	2343	3		Liquid flammable			II	E2	353 Y341	5 L 1 L	364	60 L
Bromopropanes	2344	3		Liquid flammable		A3	II	E2	353 Y341	5 L 1 L	364	60 L
							III	E1	355 Y344	60 L 10 L	366	220 L
3-Bromopropyne	2345	3		Liquid flammable			II	E2	353 Y341	5 L 1 L	364	60 L
Bromosilane	FORBIDDEN											
Bromotrifluoroethylene	2419	2.1		Gas flammable	AU 1 CA 7 IR 3 NL 1 US 3	A1		E0	FORBIDDEN		200	150 kg
Bromotrifluoromethane	1009	2.2		Gas non-flammable				E1	200	75 kg	200	150 kg
>												
Brucine	1570	6.1		Toxic	US 4	A6	I	E5	666	5 kg	673	50 kg
Bursters, explosive †	0043	1.1D							FORBIDDEN		FORBIDDEN	
Butadienes and hydrocarbon mixture, stabilized , containing more than 40% butadienes	1010	2.1		Gas flammable	AU 1 CA 7 IR 3 NL 1 US 3	A1		E0	FORBIDDEN		200	150 kg
Butadienes, stabilized	1010	2.1		Gas flammable	AU 1 CA 7 IR 3 NL 1 US 3	A1		E0	FORBIDDEN		200	150 kg
Butane	1011	2.1		Gas flammable	AU 1 CA 7 IR 3 NL 1 US 3	A1		E0	FORBIDDEN		200	150 kg
Butane, butane mixtures and mixtures having similar properties in cartridges each not exceeding 500 grams, see Receptacles , etc.												

Name	UN No.	Class or division	Subsidiary risk	Labels	State variations	Special provisions	UN packing group	Excepted quantity	Passenger and cargo aircraft		Cargo aircraft only	
									Packing instruction	Max. net quantity per package	Packing instruction	Max. net quantity per package
1	2	3	4	5	6	7	8	9	10	11	12	13
Butanedione	2346	3		Liquid flammable			II	E2	353 Y341	5 L 1 L	364	60 L
Butane-1-thiol, see Butyl mercaptan												
1,2,4-Butanetriol trinitrate	FORBIDDEN											
1-Butanol, see Butanols												
Butan-2-ol, see Butanols												
Butanols	1120	3		Liquid flammable		A3	II	E2	353 Y341	5 L 1 L	364	60 L
Butanol, secondary, see Butanols							III	E1	355 Y344	60 L 10 L	366	220 L
Butanol, tertiary, see Butanols												
Butanone, see Ethyl methyl ketone												
2-Butenal, see Crotonaldehyde, stabilized												
Butene, see Butylene												
But-1-ene-3-one, see Methyl vinyl ketone, stabilized												
1,2-Buteneoxide, see 1,2-Butylene oxide, stabilized												
2-Buten-1-ol, see Methyl alcohol												
tert-Butoxycarbonyl azide	FORBIDDEN											
Butyl acetates	1123	3		Liquid flammable		A3	II	E2	353 Y341	5 L 1 L	364	60 L
Butyl acetate, secondary, see Butyl acetates							III	E1	355 Y344	60 L 10 L	366	220 L
Butyl acid phosphate	1718	8		Corrosive			III	E1	852 Y841	5 L 1 L	856	60 L

Name	UN No.	Class or division	Subsidiary risk	Labels	State variations	Special provisions	UN packing group	Excepted quantity	Passenger and cargo aircraft		Cargo aircraft only	
									Packing instruction	Max. net quantity per package	Packing instruction	Max. net quantity per package
1	2	3	4	5	6	7	8	9	10	11	12	13
Butyl acrylates, stabilized	2348	3		Liquid flammable			III	E1	355 Y344	60 L 10 L	366	220 L
Butyl alcohols, see Butanols												
n-Butylamine	1125	3	8	Liquid flammable & Corrosive			II	E2	352 Y340	1 L 0.5 L	363	5 L
N-Butylaniline	2738	6.1		Toxic			II	E4	654 Y641	5 L 1 L	662	60 L
sec-Butyl benzene, see Butylbenzenes												
Butylbenzenes	2709	3		Liquid flammable			III	E1	355 Y344	60 L 10 L	366	220 L
n-Butyl bromide, see 1-Bromobutane												
n-Butyl chloride, see Chlorobutanes												
n-Butyl chloroformate	2743	6.1	3 8						FORBIDDEN		FORBIDDEN	
tert-Butylcyclohexyl chloroformate	2747	6.1		Toxic			III	E1	655 Y642	60 L 2 L	663	220 L
Butylene	1012	2.1		Gas flammable	AU 1 CA 7 IR 3 NL 1 US 3	A1		E0	FORBIDDEN		200	150 kg
1,2-Butylene oxide, stabilized	3022	3		Liquid flammable			II	E2	353 Y341	5 L 1 L	364	60 L
Butyl ethers, see Dibutyl ethers												
Butyl ethyl ether, see Ethyl butyl ether												
n-Butyl formate	1128	3		Liquid flammable			II	E2	353 Y341	5 L 1 L	364	60 L
tert-Butyl hydroperoxide, more than 90% with water	FORBIDDEN											
tert-Butyl hypochlorite	3255	4.2	8						FORBIDDEN		FORBIDDEN	
N,n-Butylimidazole	2690	6.1		Toxic			II	E4	654 Y641	5 L 1 L	662	60 L

Name	UN No.	Class or division	Subsidiary risk	Labels	State variations	Special provisions	UN packing group	Excepted quantity	Passenger and cargo aircraft		Cargo aircraft only	
									Packing instruction	Max. net quantity per package	Packing instruction	Max. net quantity per package
1	2	3	4	5	6	7	8	9	10	11	12	13
N-n-Butyliminazole, see N,n-Butylimidazole												
n-Butyl isocyanate	2485	6.1	3		AU 1 CA 7 IR 3 NL 1 US 3	A2			FORBIDDEN		FORBIDDEN	
tert-Butyl isocyanate	2484	6.1	3						FORBIDDEN		FORBIDDEN	
Butyl lithium, see Organometallic substance, liquid, pyrophoric, water reactive (UN No. 3394)												
Butyl mercaptan	2347	3		Liquid flammable			II	E2	353 Y341	5 L 1 L	364	60 L
n-Butyl methacrylate, stabilized	2227	3		Liquid flammable			III	E1	355 Y344	60 L 10 L	366	220 L
Butyl methyl ether	2350	3		Liquid flammable			II	E2	353 Y341	5 L 1 L	364	60 L
tert-Butyl monoperoxymaleate, more than 52%	FORBIDDEN											
tert-Butyl monoperoxyphthalate	FORBIDDEN											
Butyl nitrites	2351	3		Liquid flammable		A3	II	E2	353 Y341	5 L 1 L	364	60 L
							III	E1	355 Y344	60 L 10 L	366	220 L
tert-Butyl peroxyacetate, more than 52% and not more than 77%, when with not less than 23% diluent type A	FORBIDDEN											
tert-Butyl peroxyisobutyrate, more than 52% and not more than 77%, when with not less than 23% diluent Type A	FORBIDDEN											
Butylphenols, liquid, see Alkylphenols, liquid, n.o.s.												
Butylphenols, solid, see Alkylphenols, solid, n.o.s.												
Butyl propionates	1914	3		Liquid flammable			III	E1	355 Y344	60 L 10 L	366	220 L
p-tert-Butyltoluene, see Butyltoluenes												

Name	UN No.	Class or division	Subsidiary risk	Labels	State variations	Special provisions	UN packing group	Excepted quantity	Passenger and cargo aircraft		Cargo aircraft only	
									Packing instruction	Max. net quantity per package	Packing instruction	Max. net quantity per package
1	2	3	4	5	6	7	8	9	10	11	12	13
Butyltoluenes	2667	6.1		Toxic			III	E1	655 Y642	60 L 2 L	663	220 L
Butyltrichlorosilane	1747	8	3	Corrosive & Liquid flammable	AU 1 CA 7 IR 3 NL 1 US 3	A1	II	E0	FORBIDDEN		876	30 L
5-tert-Butyl-2,4,6-trinitro-m-xylene	2956	4.1							FORBIDDEN		FORBIDDEN	
Butyl vinyl ether, stabilized	2352	3		Liquid flammable			II	E2	353 Y341	5 L 1 L	364	60 L
But-1-yne, see Ethylacetylene, stabilized (UN No. 2452)												
1,4-Butynediol	2716	6.1		Toxic			III	E1	670 Y645	100 kg 10 kg	677	200 kg
2-Butyne-1,4-diol, see 1,4-Butynediol												
Butyraldehyde	1129	3		Liquid flammable			II	E2	353 Y341	5 L 1 L	364	60 L
Butyraldoxime	2840	3		Liquid flammable			III	E1	355 Y344	60 L 10 L	366	220 L
Butyric acid	2820	8		Corrosive			III	E1	852 Y841	5 L 1 L	856	60 L
Butyric anhydride	2739	8		Corrosive			III	E1	852 Y841	5 L 1 L	856	60 L
Butyrone, see Dipropyl ketone												
Butyronitrile	2411	3	6.1	Liquid flammable & Toxic			II	E2	352 Y341	1 L 1 L	364	60 L
Butyryl chloride, see Butyryl chloride												
Butyryl chloride	2353	3	8	Liquid flammable & Corrosive			II	E2	352 Y340	1 L 0.5 L	363	5 L
C												
Cable cutters, explosive, see Cutters, cable, explosive												
Cacodylic acid	1572	6.1		Toxic	US 4		II	E4	669 Y644	25 kg 1 kg	676	100 kg

Name	UN No.	Class or division	Subsidiary risk	Labels	State variations	Special provisions	UN packing group	Excepted quantity	Passenger and cargo aircraft		Cargo aircraft only	
									Packing instruction	Max. net quantity per package	Packing instruction	Max. net quantity per package
1	2	3	4	5	6	7	8	9	10	11	12	13
Cadmium compound*	2570	6.1		Toxic	US 4	A3 A5	I II	E5 E4	666 669 Y644	5 kg 25 kg 1 kg	673 676	50 kg 100 kg
							III	E1	670 Y645	100 kg 10 kg	677	200 kg
Caesium	1407	4.3		Danger if wet			I	E0	FORBIDDEN		487	15 kg
Caesium hydroxide	2682	8		Corrosive			II	E2	859 Y844	15 kg 5 kg	863	50 kg
Caesium hydroxide solution	2681	8		Corrosive		A3	II	E2	851 Y840	1 L 0.5 L	855	30 L
							III	E1	852 Y841	5 L 1 L	856	60 L
Caesium nitrate	1451	5.1		Oxidizer			III	E1	559 Y546	25 kg 10 kg	563	100 kg
Caffeine, see Alkaloids , etc.												
Cajeputene, see Dipentene												
Calcium	1401	4.3		Danger if wet			II	E2	484 Y475	15 kg 5 kg	490	50 kg
Calcium alloys, pyrophoric	1855	4.2							FORBIDDEN		FORBIDDEN	
Calcium arsenate	1573	6.1		Toxic	US 4		II	E4	669 Y644	25 kg 1 kg	676	100 kg
Calcium arsenate and calcium arsenite mixture, solid	1574	6.1		Toxic			II	E4	669 Y644	25 kg 1 kg	676	100 kg
Calcium bisulphite solution, see Bisulphites, aqueous solution, n.o.s.												
Calcium carbide	1402	4.3		Danger if wet	US 4		I II	E0 E2	FORBIDDEN 484 Y475	15 kg 5 kg	487 489	15 kg 50 kg
Calcium chlorate	1452	5.1		Oxidizer			II	E2	558 Y544	5 kg 2.5 kg	562	25 kg
Calcium chlorate, aqueous solution	2429	5.1		Oxidizer		A3	II	E2	550 Y540	1 L 0.5 L	554	5 L
							III	E1	551 Y541	2.5 L 1 L	555	30 L
Calcium chlorite	1453	5.1		Oxidizer			II	E2	558 Y544	5 kg 2.5 kg	562	25 kg
Calcium cyanamide with more than 0.1% of calcium carbide	1403	4.3		Danger if wet		A71	III	E1	486 Y477	25 kg 10 kg	491	100 kg
Calcium cyanide	1575	6.1		Toxic	US 4		I	E5	666	5 kg	673	50 kg

Name	UN No.	Class or division	Subsidiary risk	Labels	State variations	Special provisions	UN packing group	Excepted quantity	Passenger and cargo aircraft		Cargo aircraft only	
									Packing instruction	Max. net quantity per package	Packing instruction	Max. net quantity per package
1	2	3	4	5	6	7	8	9	10	11	12	13
Calcium dithionite	1923	4.2		Spontaneous combustion			II	E2	467	15 kg	470	50 kg
Calcium hydride	1404	4.3		Danger if wet			I	E0	FORBIDDEN		487	15 kg
Calcium hydrosulphite	1923	4.2		Spontaneous combustion			II	E2	467	15 kg	470	50 kg
Calcium hypochlorite, dry	1748	5.1		Oxidizer	US 4	A136	II	E2	558 Y544	5 kg 2.5 kg	562	25 kg
							III	E1	559 Y546	25 kg 10 kg	563	100 kg
Calcium hypochlorite, dry, corrosive with more than 39% available chlorine (8.8% available oxygen)	3485	5.1	8	Oxidizer & Corrosive		A136	II	E2	558 Y544	5 kg 2.5 kg	562	25 kg
Calcium hypochlorite, hydrated with not less than 5.5% but not more than 16% water	2880	5.1		Oxidizer	US 4	A3 A8 A136	II	E2	558 Y544	5 kg 2.5 kg	562	25 kg
							III	E1	559 Y546	25 kg 10 kg	563	100 kg
Calcium hypochlorite, hydrated, corrosive with not less than 5.5% but not more than 16% water	3487	5.1	8	Oxidizer & Corrosive		A8 A136	II	E2	558 Y544	5 kg 2.5 kg	562	25 kg
							III	E1	559 Y545	25 kg 5 kg	563	100 kg
Calcium hypochlorite, hydrated mixture with not less than 5.5% but not more than 16% water	2880	5.1		Oxidizer	US 4	A3 A8 A136	II	E2	558 Y544	5 kg 2.5 kg	562	25 kg
							III	E1	559 Y546	25 kg 10 kg	563	100 kg
Calcium hypochlorite, hydrated mixture, corrosive with not less than 5.5% but not more than 16% water	3487	5.1	8	Oxidizer & Corrosive		A8 A136	II	E2	558 Y544	5 kg 2.5 kg	562	25 kg
							III	E1	559 Y545	25 kg 5 kg	563	100 kg
Calcium hypochlorite mixture, dry with more than 39% available chlorine (8.8% available oxygen)	1748	5.1		Oxidizer	US 4	A138	II	E2	558 Y544	5 kg 2.5 kg	562	25 kg
							III	E1	559 Y546	25 kg 10 kg	563	100 kg
Calcium hypochlorite mixture, dry with more than 10% but not more than 39% available chlorine	2208	5.1		Oxidizer	US 4	A136	III	E1	559 Y546	25 kg 10 kg	563	100 kg
Calcium hypochlorite mixture, dry, corrosive with more than 39% available chlorine (8.8% available oxygen)	3485	5.1	8	Oxidizer & Corrosive		A136	II	E2	558 Y544	5 kg 2.5 kg	562	25 kg

Name	UN No.	Class or division	Subsidiary risk	Labels	State variations	Special provisions	UN packing group	Excepted quantity	Passenger and cargo aircraft		Cargo aircraft only	
									Packing instruction	Max. net quantity per package	Packing instruction	Max. net quantity per package
1	2	3	4	5	6	7	8	9	10	11	12	13
Calcium hypochlorite mixture, dry, corrosive with more than 10% but not more than 39% available chlorine	3486	5.1	8	Oxidizer & Corrosive		A136	III	E1	559 Y545	25 kg 5 kg	563	100 kg
Calcium manganese silicon	2844	4.3		Danger if wet			III	E1	486 Y477	25 kg 10 kg	491	100 kg
Calcium nitrate	1454	5.1		Oxidizer		A83	III	E1	559 Y546	25 kg 10 kg	563	100 kg
Calcium oxide	1910	8		Corrosive			III	E1	860 Y845	25 kg 5 kg	864	100 kg
Calcium perchlorate	1455	5.1		Oxidizer			II	E2	558 Y544	5 kg 2.5 kg	562	25 kg
Calcium permanganate	1456	5.1		Oxidizer			II	E2	558 Y544	5 kg 2.5 kg	562	25 kg
Calcium peroxide	1457	5.1		Oxidizer			II	E2	558 Y544	5 kg 2.5 kg	562	25 kg
Calcium phosphide	1360	4.3	6.1	Danger if wet & Toxic			I	E0	FORBIDDEN		487	15 kg
Calcium, pyrophoric	1855	4.2							FORBIDDEN		FORBIDDEN	
Calcium resinate	1313	4.1		Solid flammable			III	E1	446 Y443	25 kg 10 kg	449	100 kg
Calcium resinate, fused	1314	4.1		Solid flammable			III	E1	446 Y443	25 kg 10 kg	449	100 kg
Calcium selenate, see Selenates												
Calcium silicide	1405	4.3		Danger if wet		A3	II	E2	484 Y475	15 kg 5 kg	490	50 kg
							III	E1	486 Y477	25 kg 10 kg	491	100 kg
Calcium silicon, see Calcium silicide												
Calcium superoxide, see Calcium peroxide												
Camphanone, see Camphor, synthetic												
Camphor, synthetic	2717	4.1		Solid flammable			III	E1	446 Y443	25 kg 10 kg	449	100 kg
Camphor oil	1130	3		Liquid flammable			III	E1	355 Y344	60 L 10 L	366	220 L
Camping gas, see Receptacles, small, containing gas, or gas cartridges, etc.												

Name	UN No.	Class or division	Subsidiary risk	Labels	State variations	Special provisions	UN packing group	Excepted quantity	Passenger and cargo aircraft		Cargo aircraft only	
									Packing instruction	Max. net quantity per package	Packing instruction	Max. net quantity per package
1	2	3	4	5	6	7	8	9	10	11	12	13
+ Capacitor, asymmetric (with an energy storage capacity greater than 0.3Wh)	3508	9		Miscellaneous		A196		E0	971	No limit	971	No limit
≠ Capacitor, electric double layer (with an energy storage capacity greater than 0.3 Wh)	3499	9		Miscellaneous		A186		E0	971	No limit	971	No limit
Caproic acid Caps, toy 1, see Fireworks (UN Nos. 0333, 0336, 0337)	2829	8		Corrosive			III	E1	852 Y841	5 L 1 L	856	60 L
Carbamate pesticide, liquid, flammable, toxic* , flash point less than 23°C	2758	3	6.1	Liquid flammable & Toxic		A4	I II	E0 E2	FORBIDDEN 352 Y341	1 L 1 L	361 364	30 L 60 L
Carbamate pesticide, liquid, toxic*	2992	6.1		Toxic		A3 A4	I II III	E5 E4 E1	652 654 Y641 655 Y642	1 L 5 L 1 L 60 L 2 L	658 662 663	30 L 60 L 220 L
Carbamate pesticide, liquid, toxic, flammable* , flash point not less than 23°C	2991	6.1	3	Toxic & Liquid flammable		A3 A4	I II III	E5 E4 E1	652 654 Y641 655 Y642	1 L 5 L 1 L 60 L 2 L	658 662 663	30 L 60 L 220 L
Carbamate pesticide, solid, toxic*	2757	6.1		Toxic		A3 A5	I II III	E5 E4 E1	666 669 Y644 670 Y645	5 kg 25 kg 1 kg 100 kg 10 kg	673 676 677	50 kg 100 kg 200 kg
Carbolic acid, see Phenol, solid or Phenol, molten												
Carbolic acid solution, see Phenol solution												
Carbon , animal or vegetable origin	1361	4.2		Spontaneous combustion	AU 1 CA 7 IR 3 NL 1 US 3	A2 A3	II		FORBIDDEN		470	50 kg
Carbon, activated	1362	4.2		Spontaneous combustion		A3	III	E1	472	0.5 kg	472	0.5 kg
Carbon bisulphide, see Carbon disulphide												

Name	UN No.	Class or division	Subsidiary risk	Labels	State variations	Special provisions	UN packing group	Excepted quantity	Passenger and cargo aircraft		Cargo aircraft only	
									Packing instruction	Max. net quantity per package	Packing instruction	Max. net quantity per package
1	2	3	4	5	6	7	8	9	10	11	12	13
Carbon black (animal or vegetable origin), see Carbon												
Carbon dioxide	1013	2.2		Gas non-flammable				E1	200	75 kg	200	150 kg
Carbon dioxide and ethylene oxide mixture, see Ethylene oxide and carbon dioxide mixture , etc.												
Carbon dioxide, refrigerated liquid	2187	2.2		Gas non-flammable				E1	202	50 kg	202	500 kg
Carbon dioxide, solid	1845	9		Miscellaneous		A48 A151		E0	954	200 kg	954	200 kg
Carbon disulphide	1131	3	6.1						FORBIDDEN		FORBIDDEN	
Carbonic anhydride, see Carbon dioxide , etc.												
Carbon monoxide, compressed	1016	2.3	2.1		AU 1 CA 7 IR 3 NL 1 US 3	A2			FORBIDDEN		FORBIDDEN	
Carbon oxysulphide, see Carbonyl sulphide												
Carbon tetrabromide	2516	6.1		Toxic			III	E1	670 Y645	100 kg 10 kg	677	200 kg
Carbon tetrachloride	1846	6.1		Toxic	US 4		II	E4	654 Y641	5 L 1 L	661	60 L
Carbonyl chloride, see Phosgene												
Carbonyl fluoride	2417	2.3	8		AU 1 CA 7 IR 3 NL 1 US 3	A2			FORBIDDEN		FORBIDDEN	
Carbonyl sulphide	2204	2.3	2.1		AU 1 CA 7 IR 3 NL 1 US 3	A2			FORBIDDEN		FORBIDDEN	
Cartridge cases, empty, primed, see Cases, cartridge, empty, with primer												

Name	UN No.	Class or division	Subsidiary risk	Labels	State variations	Special provisions	UN packing group	Excepted quantity	Passenger and cargo aircraft		Cargo aircraft only	
									Packing instruction	Max. net quantity per package	Packing instruction	Max. net quantity per package
1	2	3	4	5	6	7	8	9	10	11	12	13
Cartridges, actuating, for fire extinguisher or apparatus valve, † see Cartridges, power device (UN Nos. 0275, 0276, 0323, 0381)												
Cartridges, explosive, see Charges, demolition												
Cartridges, flash †	0049	1.1G							FORBIDDEN		FORBIDDEN	
Cartridges, flash †	0050	1.3G		Explosive				E0	FORBIDDEN		135	75 kg
Cartridges for tools, blank †	0014	1.4S		Explosive 1.4				E0	130	25 kg	130	100 kg
Cartridges for weapons with bursting charge †	0005	1.1F							FORBIDDEN		FORBIDDEN	
Cartridges for weapons with bursting charge †	0006	1.1E							FORBIDDEN		FORBIDDEN	
Cartridges for weapons with bursting charge †	0007	1.2F							FORBIDDEN		FORBIDDEN	
Cartridges for weapons with bursting charge †	0321	1.2E							FORBIDDEN		FORBIDDEN	
Cartridges for weapons with bursting charge †	0348	1.4F							FORBIDDEN		FORBIDDEN	
Cartridges for weapons with bursting charge †	0412	1.4E		Explosive 1.4				E0	FORBIDDEN		130	75 kg
Cartridges for weapons, blank †	0014	1.4S		Explosive 1.4				E0	130	25 kg	130	100 kg
Cartridges for weapons, blank †	0326	1.1C							FORBIDDEN		FORBIDDEN	
Cartridges for weapons, blank †	0327	1.3C							FORBIDDEN		FORBIDDEN	
Cartridges for weapons, blank †	0338	1.4C		Explosive 1.4				E0	FORBIDDEN		130	75 kg
Cartridges for weapons, blank †	0413	1.2C							FORBIDDEN		FORBIDDEN	
Cartridges for weapons, inert projectile †	0012	1.4S		Explosive 1.4				E0	130	25 kg	130	100 kg
Cartridges for weapons, inert projectile †	0328	1.2C							FORBIDDEN		FORBIDDEN	
Cartridges for weapons, inert projectile †	0339	1.4C		Explosive 1.4				E0	FORBIDDEN		130	75 kg
Cartridges for weapons, inert projectile †	0417	1.3C							FORBIDDEN		FORBIDDEN	
Cartridges, illuminating, see Ammunition, illuminating, etc.												

Name	UN No.	Class or division	Subsidiary risk	Labels	State variations	Special provisions	UN packing group	Excepted quantity	Passenger and cargo aircraft		Cargo aircraft only	
									Packing instruction	Max. net quantity per package	Packing instruction	Max. net quantity per package
									10	11	12	13
Cartridges, oil well †	0277	1.3C							FORBIDDEN		FORBIDDEN	
Cartridges, oil well †	0278	1.4C		Explosive 1.4				E0	FORBIDDEN		134	75 kg
Cartridges, power device †	0275	1.3C		Explosive				E0	FORBIDDEN		134	75 kg
Cartridges, power device †	0276	1.4C		Explosive 1.4				E0	FORBIDDEN		134	75 kg
Cartridges, power device †	0323	1.4S		Explosive 1.4		A165		E0	134	25 kg	134	100 kg
Cartridges, power device †	0381	1.2C							FORBIDDEN		FORBIDDEN	
Cartridges, signal †	0054	1.3G		Explosive				E0	FORBIDDEN		135	75 kg
Cartridges, signal †	0312	1.4G		Explosive 1.4				E0	FORBIDDEN		135	75 kg
Cartridges, signal †	0405	1.4S		Explosive 1.4				E0	135	25 kg	135	100 kg
Cartridges, small arms †	0012	1.4S		Explosive 1.4				E0	130	25 kg	130	100 kg
Cartridges, small arms †	0339	1.4C		Explosive 1.4				E0	FORBIDDEN		130	75 kg
Cartridges, small arms †	0417	1.3C							FORBIDDEN		FORBIDDEN	
Cartridges, small arms, blank †	0014	1.4S		Explosive 1.4				E0	130	25 kg	130	100 kg
Cartridges, small arms, blank †	0327	1.3C							FORBIDDEN		FORBIDDEN	
Cartridges, small arms, blank †	0338	1.4C		Explosive 1.4				E0	FORBIDDEN		130	75 kg
Cartridges, starter, jet engine, see Cartridges, power device												
Cases, cartridge, empty, with primer †	0055	1.4S		Explosive 1.4				E0	136	25 kg	136	100 kg
Cases, cartridge, empty, with primer †	0379	1.4C		Explosive 1.4				E0	FORBIDDEN		136	75 kg
Cases, combustible, empty, without primer †	0446	1.4C		Explosive 1.4				E0	FORBIDDEN		136	75 kg
Cases, combustible, empty, without primer †	0447	1.3C							FORBIDDEN		FORBIDDEN	
Casinghead gasoline, see Gasoline or Petrol or Motor spirit (UN No. 1203)												
Castor beans	2969	9		Miscellaneous		A31	II	E2	956	No limit	956	No limit
Castor flake	2969	9		Miscellaneous		A31	II	E2	956	No limit	956	No limit
Castor meal	2969	9		Miscellaneous		A31	II	E2	956	No limit	956	No limit
Castor pomace	2969	9		Miscellaneous		A31	II	E2	956	No limit	956	No limit

Name	UN No.	Class or division	Subsidiary risk	Labels	State variations	Special provisions	UN packing group	Excepted quantity	Passenger and cargo aircraft		Cargo aircraft only	
									Packing instruction	Max. net quantity per package	Packing instruction	Max. net quantity per package
1	2	3	4	5	6	7	8	9	10	11	12	13
Caustic alkali liquid, n.o.s.*	1719	8		Corrosive		A3	II	E2	851 Y840	1 L 0.5 L	855	30 L
Caustic potash, see Potassium hydroxide solution							III	E1	852 Y841	5 L 1 L	856	60 L
Caustic soda, see Sodium hydroxide solution												
Caustic soda liquor, see Sodium hydroxide solution												
‡ Cells, containing sodium †	3292	4.3		Danger if wet		A94		E0	492	25 kg	492	No limit
Celluloid , in blocks, rods, rolls, sheets, tubes, etc. (except scrap)	2000	4.1		Solid flammable		A3 A48	III	E1	456	25 kg	456	100 kg
Celluloid, scrap	2002	4.2			AU 1 CA 7 IR 3 NL 1 US 3	A2 A3			FORBIDDEN		FORBIDDEN	
Cement, see Adhesives containing flammable liquid												
Cerium , slabs, ingots or rods	1333	4.1		Solid flammable			II	E2	445 Y441	15 kg 5 kg	448	50 kg
Cerium , turnings or gritty powder	3078	4.3		Danger if wet			II	E2	484 Y475	15 kg 5 kg	490	50 kg
Cer mischmetall, see Ferrocium												
Charcoal, activated, see Carbon, activated												
Charcoal, non-activated, see Carbon												
Charcoal screenings, wet	FORBIDDEN											
Charcoal, wet	FORBIDDEN											
Charges, bursting, plastics bonded	0457	1.1D							FORBIDDEN		FORBIDDEN	
Charges, bursting, plastics bonded	0458	1.2D							FORBIDDEN		FORBIDDEN	

Name	UN No.	Class or division	Subsidiary risk	Labels	State variations	Special provisions	UN packing group	Excepted quantity	Passenger and cargo aircraft		Cargo aircraft only	
									Packing instruction	Max. net quantity per package	Packing instruction	Max. net quantity per package
1	2	3	4	5	6	7	8	9	10	11	12	13
Charges, bursting, plastics bonded	0459	1.4D		Explosive 1.4				E0	FORBIDDEN		130	75 kg
Charges, bursting, plastics bonded	0460	1.4S		Explosive 1.4		A165		E0	130	25 kg	130	100 kg
Charges, demolition †	0048	1.1D							FORBIDDEN		FORBIDDEN	
Charges, depth †	0056	1.1D							FORBIDDEN		FORBIDDEN	
Charges, expelling, explosive, for fire extinguishers, see Cartridges, power device												
Charges, explosive, commercial without detonator †	0442	1.1D							FORBIDDEN		FORBIDDEN	
Charges, explosive, commercial without detonator †	0443	1.2D							FORBIDDEN		FORBIDDEN	
Charges, explosive, commercial without detonator †	0444	1.4D		Explosive 1.4				E0	FORBIDDEN		137	75 kg
Charges, explosive, commercial without detonator †	0445	1.4S		Explosive 1.4		A165		E0	137	25 kg	137	100 kg
Charges, propelling †	0271	1.1C							FORBIDDEN		FORBIDDEN	
Charges, propelling †	0272	1.3C							FORBIDDEN		FORBIDDEN	
Charges, propelling †	0415	1.2C							FORBIDDEN		FORBIDDEN	
Charges, propelling †	0491	1.4C		Explosive 1.4				E0	FORBIDDEN		143	75 kg
Charges, propelling, for cannon †	0242	1.3C							FORBIDDEN		FORBIDDEN	
Charges, propelling, for cannon †	0279	1.1C							FORBIDDEN		FORBIDDEN	
Charges, propelling, for cannon †	0414	1.2C							FORBIDDEN		FORBIDDEN	
Charges, shaped without detonator †	0059	1.1D			AU 2 CA 7 IR 3 NL 1 US 3	A2			FORBIDDEN		FORBIDDEN	
Charges, shaped without detonator †	0439	1.2D							FORBIDDEN		FORBIDDEN	
Charges, shaped without detonator †	0440	1.4D		Explosive 1.4	AU 1 CA 7 IR 3 NL 1 US 3	A1		E0	FORBIDDEN		137	75 kg
Charges, shaped without detonator †	0441	1.4S		Explosive 1.4		A165		E0	137	25 kg	137	100 kg

Name	UN No.	Class or division	Subsidiary risk	Labels	State variations	Special provisions	UN packing group	Excepted quantity	Passenger and cargo aircraft		Cargo aircraft only	
									Packing instruction	Max. net quantity per package	Packing instruction	Max. net quantity per package
1	2	3	4	5	6	7	8	9	10	11	12	13
Charges, shaped, flexible, linear †	0237	1.4D		Explosive 1.4				E0	FORBIDDEN		138	75 kg
Charges, shaped, flexible, linear †	0288	1.1D							FORBIDDEN		FORBIDDEN	
Charges, supplementary, explosive †	0060	1.1D							FORBIDDEN		FORBIDDEN	
≠ Chemical kit	3316	9		Miscellaneous		A44 A163	II III	E0	960 Y960 960 Y960	10 kg 1 kg 10 kg 1 kg	960 960	10 kg 10 kg
Chemical sample, toxic	3315	6.1				A106			FORBIDDEN		FORBIDDEN	
Chemical under pressure, n.o.s.*	3500	2.2		Gas non-flammable		A187		E0	218	75 kg	218	150 kg
Chemical under pressure, corrosive, n.o.s.*	3503	2.2	8	Gas non-flammable & Corrosive	AU 1 CA 7 IR 3 NL 1 US 3	A1 A187		E0	FORBIDDEN		218	100 kg
Chemical under pressure, flammable, n.o.s.*	3501	2.1		Gas flammable	AU 1 CA 7 IR 3 NL 1 US 3	A1 A187		E0	FORBIDDEN		218	75 kg
Chemical under pressure, flammable, corrosive, n.o.s.*	3505	2.1	8	Gas flammable & Corrosive	AU 1 CA 7 IR 3 NL 1 US 3	A1 A187		E0	FORBIDDEN		218	75 kg
Chemical under pressure, flammable, toxic, n.o.s.*	3504	2.1	6.1	Gas flammable & Toxic	AU 1 CA 7 IR 3 NL 1 US 3	A1 A187		E0	FORBIDDEN		218	75 kg
Chemical under pressure, toxic, n.o.s.*	3502	2.2	6.1	Gas non-flammable & Toxic	AU 1 CA 7 IR 3 NL 1 US 3	A1 A187		E0	FORBIDDEN		218	100 kg
Chile saltpetre, see Sodium nitrate												
Chloral, anhydrous, stabilized	2075	6.1		Toxic			II	E4	654 Y641	5 L 1 L	662	60 L
Chlorate and borate mixture	1458	5.1		Oxidizer		A3	II III	E2 E1	558 Y544 559 Y546	5 kg 2.5 kg 25 kg 10 kg	562 563	25 kg 100 kg

Name	UN No.	Class or division	Subsidiary risk	Labels	State variations	Special provisions	UN packing group	Excepted quantity	Passenger and cargo aircraft		Cargo aircraft only	
									Packing instruction	Max. net quantity per package	Packing instruction	Max. net quantity per package
1	2	3	4	5	6	7	8	9	10	11	12	13
Chlorate and magnesium chloride mixture, solid	1459	5.1		Oxidizer		A3	II	E2	558	5 kg	562	25 kg
									Y544	2.5 kg		
									559	25 kg		
									Y546	10 kg	563	100 kg
Chlorate and magnesium chloride mixture solution	3407	5.1		Oxidizer		A3	II	E2	550	1 L	554	5 L
									Y540	0.5 L		
									551	2.5 L		
									Y541	1 L	555	30 L
Chlorates, inorganic, n.o.s.*	1461	5.1		Oxidizer		A171	II	E2	558	5 kg	562	25 kg
									Y544	2.5 kg		
Chlorates, inorganic, aqueous solution, n.o.s.*	3210	5.1		Oxidizer		A3	II	E2	550	1 L	554	5 L
									Y540	0.5 L		
									551	2.5 L		
									Y541	1 L	555	30 L
Chloric acid, aqueous solution with not more than 10% chloric acid	2626	5.1			AU 1 CA 7 IR 3 NL 1 US 3	A2			FORBIDDEN		FORBIDDEN	
Chlorine	1017	2.3	5.1 8		AU 1 CA 7 IR 3 NL 1 US 3	A2			FORBIDDEN		FORBIDDEN	
+ Chlorine, adsorbed	3520	2.3	5.1 8			A2		E0	FORBIDDEN		FORBIDDEN	
Chlorine azide	FORBIDDEN											
Chlorine dioxide	FORBIDDEN											
Chlorine pentafluoride	2548	2.3	5.1 8		AU 1 CA 7 IR 3 NL 1 US 3	A2			FORBIDDEN		FORBIDDEN	
Chlorine trifluoride	1749	2.3	5.1 8		AU 1 CA 7 IR 3 NL 1 US 3	A2			FORBIDDEN		FORBIDDEN	
Chlorites, inorganic, n.o.s.*	1462	5.1		Oxidizer		A172	II	E2	558	5 kg	562	25 kg
									Y544	2.5 kg		

Name	UN No.	Class or division	Subsidiary risk	Labels	State variations	Special provisions	UN packing group	Excepted quantity	Passenger and cargo aircraft		Cargo aircraft only	
									Packing instruction	Max. net quantity per package	Packing instruction	Max. net quantity per package
1	2	3	4	5	6	7	8	9	10	11	12	13
Chlorite solution	1908	8		Corrosive		A3	II	E2	851 Y840 852 Y841	1 L 0.5 L 5 L 1 L	855 856	30 L 60 L
Chloroacetaldehyde, see 2-Chloroethanal												
Chloroacetic acid, molten	3250	6.1	8						FORBIDDEN		FORBIDDEN	
Chloroacetic acid, solid	1751	6.1	8	Toxic & Corrosive			II	E4	668 Y644	15 kg 1 kg	675	50 kg
Chloroacetic acid solution	1750	6.1	8	Toxic & Corrosive			II	E4	653 Y640	1 L 0.5 L	660	30 L
Chloroacetone, stabilized	1695	6.1	3 8						FORBIDDEN		FORBIDDEN	
Chloroacetone (unstabilized)	FORBIDDEN											
Chloroacetonitrile	2668	6.1	3		AU 1 CA 7 NL 1 US 3				FORBIDDEN		FORBIDDEN	
Chloroacetophenone, liquid	3416	6.1		Toxic	AU 1 CA 7 IR 3 NL 1 US 3	A1	II	E0	FORBIDDEN		661	60 L
Chloroacetophenone, solid	1697	6.1		Toxic	AU 1 CA 7 IR 3 NL 1 US 3	A1	II	E0	FORBIDDEN		676	100 kg
Chloroacetyl chloride	1752	6.1	8		AU 1 CA 7 IR 3 NL 1 US 3	A2			FORBIDDEN		FORBIDDEN	
Chloroanilines, liquid	2019	6.1		Toxic			II	E4	654 Y641	5 L 1 L	662	60 L
Chloroanilines, solid	2018	6.1		Toxic			II	E4	669 Y644	25 kg 1 kg	676	100 kg
Chloroanisidines	2233	6.1		Toxic			III	E1	670 Y645	100 kg 10 kg	677	200 kg
Chlorobenzene	1134	3		Liquid flammable	US 4		III	E1	355 Y344	60 L 10 L	366	220 L

Name	UN No.	Class or division	Subsidiary risk	Labels	State variations	Special provisions	UN packing group	Excepted quantity	Passenger and cargo aircraft		Cargo aircraft only	
									Packing instruction	Max. net quantity per package	Packing instruction	Max. net quantity per package
1	2	3	4	5	6	7	8	9	10	11	12	13
Chlorobenzotrifluorides	2234	3		Liquid flammable			III	E1	355 Y344	60 L 10 L	366	220 L
Chlorobenzyl chlorides, liquid	2235	6.1		Toxic			III	E1	655 Y642	60 L 2 L	663	220 L
Chlorobenzyl chlorides, solid	3427	6.1		Toxic			III	E1	670 Y645	100 kg 10 kg	677	200 kg
1-Chloro-3-bromopropane, see 1-Bromo-3-chloropropane												
1-Chlorobutane, see Chlorobutanes												
2-Chlorobutane, see Chlorobutanes												
Chlorobutanes	1127	3		Liquid flammable			II	E2	353 Y341	5 L 1 L	364	60 L
Chlorocresols, solid	3437	6.1		Toxic			II	E4	669 Y644	25 kg 1 kg	676	100 kg
Chlorocresols solution	2669	6.1		Toxic		A3	II III	E4 E1	654 Y641 655 Y642	5 L 1 L 60 L 2 L	662 663	60 L 220 L
Chlorodifluorobromomethane	1974	2.2		Gas non-flammable				E1	200	75 kg	200	150 kg
1-Chloro-1,1-difluoroethane	2517	2.1		Gas flammable	AU 1 CA 7 IR 3 NL 1 US 3	A1		E0	FORBIDDEN		200	150 kg
Chlorodifluoromethane	1018	2.2		Gas non-flammable				E1	200	75 kg	200	150 kg
Chlorodifluoromethane and chloropentafluoroethane mixture with fixed boiling point, with approximately 49% chlorodifluoromethane	1973	2.2		Gas non-flammable				E1	200	75 kg	200	150 kg
3-Chloro-1,2-dihydroxypropane, see Glycerol alpha-monochlorohydrin												
Chlorodimethyl ether, see Methyl chloromethyl ether												
Chlorodinitrobenzenes, liquid	1577	6.1		Toxic		A113	II	E4	654 Y641	5 L 1 L	662	60 L
Chlorodinitrobenzenes, solid	3441	6.1		Toxic		A113	II	E4	669 Y644	25 kg 1 kg	676	100 kg
2-Chloroethanal	2232	6.1							FORBIDDEN		FORBIDDEN	

Name	UN No.	Class or division	Subsidiary risk	Labels	State variations	Special provisions	UN packing group	Excepted quantity	Passenger and cargo aircraft		Cargo aircraft only	
									Packing instruction	Max. net quantity per package	Packing instruction	Max. net quantity per package
1	2	3	4	5	6	7	8	9	10	11	12	13
Chloroethane, see Ethyl chloride												
Chloroethane nitrile, see Chloroacetonitrile												
2-Chloroethanol, see Ethylene chlorohydrin												
Chloroform	1888	6.1		Toxic	US 4		III	E1	680 Y680	60 L 2 L	680	220 L
Chloroformates, toxic, corrosive, n.o.s.*	3277	6.1	8	Toxic & Corrosive			II	E4	653 Y640	1 L 0.5 L	660	30 L
Chloroformates, toxic, corrosive, flammable, n.o.s.*	2742	6.1	3 8	Toxic & Liquid flammable & Corrosive			II	E4	653 Y640	1 L 0.5 L	660	30 L
Chloromethane, see Methyl chloride												
1-Chloro-3-methylbutane, see Amyl chloride												
2-Chloro-2-methylbutane, see Amyl chloride												
Chloromethyl chloroformate	2745	6.1	8	Toxic & Corrosive			II	E4	653 Y640	1 L 0.5 L	660	30 L
Chloromethyl cyanide, see Chloroacetonitrile												
Chloromethyl ethyl ether	2354	3	6.1	Liquid flammable & Toxic			II	E2	352 Y341	1 L 1 L	364	60 L
Chloromethyl methyl ether, see Methyl chloromethyl ether												
3-Chloro-4-methylphenyl isocyanate, liquid	2236	6.1		Toxic			II	E4	654 Y641	5 L 1 L	662	60 L
3-Chloro-4-methylphenyl isocyanate, solid	3428	6.1		Toxic			II	E4	669 Y644	25 kg 1 kg	676	100 kg
3-Chloro-2-methylprop-1-ene, see Methylallyl chloride												
Chloronitroanilines	2237	6.1		Toxic			III	E1	670 Y645	100 kg 10 kg	677	200 kg
Chloronitrobenzenes, liquid	3409	6.1		Toxic		A113	II	E4	654 Y641	5 L 1 L	662	60 L

Name	UN No.	Class or division	Subsidiary risk	Labels	State variations	Special provisions	UN packing group	Excepted quantity	Passenger and cargo aircraft		Cargo aircraft only	
									Packing instruction	Max. net quantity per package	Packing instruction	Max. net quantity per package
1	2	3	4	5	6	7	8	9	10	11	12	13
Chloronitrobenzenes, solid	1578	6.1		Toxic		A113	II	E4	669 Y644	25 kg 1 kg	676	100 kg
Chloronitrotoluenes, liquid	2433	6.1		Toxic			III	E1	655 Y642	60 L 2 L	663	220 L
Chloronitrotoluenes, solid	3457	6.1		Toxic			III	E1	670 Y645	100 kg 10 kg	677	200 kg
Chloropentafluoroethane	1020	2.2		Gas non-flammable				E1	200	75 kg	200	150 kg
3-Chloroperoxybenzoic acid, more than 57% and not more than 86%, when with 14% or more inert solid	FORBIDDEN											
Chlorophenolates, liquid	2904	8		Corrosive			III	E1	852 Y841	5 L 1 L	856	60 L
Chlorophenolates, solid	2905	8		Corrosive			III	E1	860 Y845	25 kg 5 kg	864	100 kg
Chlorophenols, liquid	2021	6.1		Toxic	US 4		III	E1	655 Y642	60 L 2 L	663	220 L
Chlorophenols, solid	2020	6.1		Toxic	US 4	A25	III	E1	670 Y645	100 kg 10 kg	677	200 kg
Chlorophenyltrichlorosilane	1753	8		Corrosive	AU 1 CA 7 IR 3 NL 1 US 3	A1	II	E0	FORBIDDEN		876	30 L
Chloropicrin	1580	6.1							FORBIDDEN		FORBIDDEN	
Chloropicrin and methyl bromide mixture with more than 2% chloropicrin	1581	2.3			AU 1 CA 7 IR 3 NL 1 US 3	A2			FORBIDDEN		FORBIDDEN	
Chloropicrin and methyl chloride mixture	1582	2.3			AU 1 CA 7 IR 3 NL 1 US 3	A2			FORBIDDEN		FORBIDDEN	
Chloropicrin mixture, n.o.s.*	1583	6.1			AU 1 CA 7 IR 3 NL 1 US 3	A2 A3 A137			FORBIDDEN		FORBIDDEN	
Chloroplatinic acid, solid	2507	8		Corrosive			III	E1	860 Y845	25 kg 5 kg	864	100 kg
Chloroprene, stabilized	1991	3	6.1	Liquid flammable & Toxic			I	E0	FORBIDDEN		361	30 L

Name	UN No.	Class or division	Subsidiary risk	Labels	State variations	Special provisions	UN packing group	Excepted quantity	Passenger and cargo aircraft		Cargo aircraft only	
									Packing instruction	Max. net quantity per package	Packing instruction	Max. net quantity per package
1	2	3	4	5	6	7	8	9	10	11	12	13
Chloroprene, uninhibited	FORBIDDEN											
1-Chloropropane	1278	3		Liquid flammable	AU 1 CA 7 IR 3 NL 1 US 3	A1	II	E0	FORBIDDEN		364	60 L
2-Chloropropane	2356	3		Liquid flammable			I	E3	351	1 L	361	30 L
3-Chloro-propanediol-1,2, see Glycerol alpha-monochlorohydrin												
3-Chloropropanol-1	2849	6.1		Toxic			III	E1	655 Y642	60 L 2 L	663	220 L
2-Chloropropene	2456	3		Liquid flammable			I	E3	351	1 L	361	30 L
3-Chloropropene, see Allyl chloride												
3-Chloroprop-1-ene, see Allyl chloride												
2-Chloropropionic acid	2511	8		Corrosive		A3	III	E1	852 Y841	5 L 1 L	856	60 L
2-Chloropyridine	2822	6.1		Toxic			II	E4	654 Y641	5 L 1 L	662	60 L
Chlorosilanes, corrosive, n.o.s.	2987	8		Corrosive	AU 1 CA 7 IR 3 NL 1 US 3	A1	II	E0	FORBIDDEN		876	30 L
Chlorosilanes, corrosive, flammable, n.o.s.	2986	8	3	Corrosive & Liquid flammable	AU 1 CA 7 IR 3 NL 1 US 3	A1	II	E0	FORBIDDEN		876	30 L
Chlorosilanes, flammable, corrosive, n.o.s.	2985	3	8	Liquid flammable & Corrosive			II	E0	FORBIDDEN		377	5 L
Chlorosilanes, toxic, corrosive, n.o.s.*	3361	6.1	8	Toxic & Corrosive			II	E0	FORBIDDEN		681	30 L
Chlorosilanes, toxic, corrosive, flammable, n.o.s.*	3362	6.1	3 8	Toxic & Liquid flammable & Corrosive			II	E0	FORBIDDEN		681	30 L
Chlorosilanes, water-reactive, flammable, corrosive, n.o.s.	2988	4.3	3 8	Danger if wet & Liquid flammable & Corrosive			I	E0	FORBIDDEN		480	1 L

Name	UN No.	Class or division	Subsidiary risk	Labels	State variations	Special provisions	UN packing group	Excepted quantity	Passenger and cargo aircraft		Cargo aircraft only	
									Packing instruction	Max. net quantity per package	Packing instruction	Max. net quantity per package
1	2	3	4	5	6	7	8	9	10	11	12	13
Chlorosulphonic acid (with or without sulphur trioxide)	1754	8							FORBIDDEN		FORBIDDEN	
1-Chloro-1,2,2,2-tetrafluoroethane	1021	2.2		Gas non-flammable				E1	200	75 kg	200	150 kg
Chlorotoluenes	2238	3		Liquid flammable			III	E1	355 Y344	60 L 10 L	366	220 L
4-Chloro-o-toluidine hydrochloride, solid	1579	6.1		Toxic	US 4		III	E1	670 Y645	100 kg 10 kg	677	200 kg
4-Chloro-o-toluidine hydrochloride solution	3410	6.1		Toxic		A3	III	E1	655 Y642	60 L 2 L	663	220 L
Chlorotoluidines, liquid	3429	6.1		Toxic			III	E1	655 Y642	60 L 2 L	663	220 L
Chlorotoluidines, solid	2239	6.1		Toxic			III	E1	670 Y645	100 kg 10 kg	677	200 kg
1-Chloro-2,2,2-trifluoroethane	1983	2.2		Gas non-flammable				E1	200	75 kg	200	150 kg
Chlorotrifluoroethylene, see Trifluorochloroethylene, stabilized (UN No. 1082)												
Chlorotrifluoromethane	1022	2.2		Gas non-flammable				E1	200	75 kg	200	150 kg
Chlorotrifluoromethane and trifluoromethane azeotropic mixture with approximately 60% chlorotrifluoromethane	2599	2.2		Gas non-flammable				E1	200	75 kg	200	150 kg
Chromic acid, solid, see Chromium trioxide, anhydrous												
Chromic acid solution	1755	8		Corrosive		A3	II	E2	851 Y840	1 L 0.5 L	855	30 L
							III	E1	852 Y841	5 L 1 L	856	60 L
Chromic anhydride, solid, see Chromium trioxide, anhydrous												
Chromic fluoride, solid	1756	8		Corrosive			II	E2	859 Y844	15 kg 5 kg	863	50 kg
Chromic fluoride solution	1757	8		Corrosive		A3	II	E2	851 Y840	1 L 0.5 L	855	30 L
							III	E1	852 Y841	5 L 1 L	856	60 L
Chromic nitrate, see Chromium nitrate												
Chromic trioxide, see Chromium trioxide, anhydrous												

Name	UN No.	Class or division	Subsidiary risk	Labels	State variations	Special provisions	UN packing group	Excepted quantity	Passenger and cargo aircraft		Cargo aircraft only	
									Packing instruction	Max. net quantity per package	Packing instruction	Max. net quantity per package
1	2	3	4	5	6	7	8	9	10	11	12	13
Chromium (VI) dichloride dioxide, see Chromium oxychloride												
Chromium (III) fluoride, solid, see Chromic fluoride, solid												
Chromium nitrate	2720	5.1		Oxidizer			III	E1	559 Y546	25 kg 10 kg	563	100 kg
Chromium (III) nitrate, see Chromium nitrate												
Chromium oxychloride	1758	8		Corrosive			I	E0	850	0.5 L	854	2.5 L
Chromium trioxide, anhydrous	1463	5.1	6.1 8	Oxidizer & Toxic & Corrosive	US 4		II	E2	558 Y544	5 kg 2.5 kg	562	25 kg
Chromosulphuric acid	2240	8		Corrosive			I	E0	850	0.5 L	854	2.5 L
‡ Chrysotile, see Asbestos, chrysotile (UN 2590), etc.												
Cigar and cigarette lighter fluid, see Flammable liquid, n.o.s.												
Cigar and cigarette lighters, charged with fuel, see Lighters (cigarettes), etc.												
Cinene, see Dipentene												
Cinnamene, see Styrene monomer, stabilized												
Cinnamol, see Styrene monomer, stabilized												
Clinical waste, unspecified, n.o.s.	3291	6.2		Infectious		A117	II	E0	622	No limit	622	No limit
Coal briquettes, hot	FORBIDDEN											
Coal gas, compressed †	1023	2.3	2.1		AU 1 CA 7 IR 3 NL 1 US 3	A2			FORBIDDEN		FORBIDDEN	

Name	UN No.	Class or division	Subsidiary risk	Labels	State variations	Special provisions	UN packing group	Excepted quantity	Passenger and cargo aircraft		Cargo aircraft only	
									Packing instruction	Max. net quantity per package	Packing instruction	Max. net quantity per package
1	2	3	4	5	6	7	8	9	10	11	12	13
Coal tar distillates, flammable	1136	3		Liquid flammable		A3	II	E2	353 Y341 355 Y344	5 L 1 L 60 L 10 L	364 366	60 L 220 L
Coal tar naphtha, see Petroleum distillates, n.o.s. or Petroleum products, n.o.s.												
Coal tar oil, see Coal tar distillates, flammable												
Coating solution (includes surface treatments or coatings used for industrial or other purposes such as vehicle undercoating, drum or barrel lining) †	1139	3		Liquid flammable		A3	I II III	E3 E2 E1	351 353 Y341 355 Y344	1 L 5 L 1 L 60 L 10 L	361 364 366	30 L 60 L 220 L
Cobalt naphthenates, powder	2001	4.1		Solid flammable			III	E1	446 Y443	25 kg 10 kg	449	100 kg
Cobalt resinate, precipitated	1318	4.1		Solid flammable			III	E1	446 Y443	25 kg 10 kg	449	100 kg
Cocculus, see Toxins, extracted from living sources, n.o.s.												
Coke, hot		FORBIDDEN										
Collodion cottons, see Nitrocellulose , etc. (UN Nos. 0340, 0341, 0342, 2059, 2555, 2556, 2557)												
Cologne spirits, see Perfumery products etc.												
Components, explosive train, n.o.s.* †	0382	1.2B								FORBIDDEN	FORBIDDEN	
Components, explosive train, n.o.s.* †	0383	1.4B		Explosive 1.4		A62		E0		FORBIDDEN	101	75 kg
Components, explosive train, n.o.s.* †	0384	1.4S		Explosive 1.4		A62		E0	101	25 kg	101	100 kg
Components, explosive train, n.o.s.* †	0461	1.1B								FORBIDDEN	FORBIDDEN	
Composition B, see Hexolite , etc.												
Compressed gas, n.o.s.*	1956	2.2		Gas non-flammable				E1	200	75 kg	200	150 kg

Name	UN No.	Class or division	Subsidiary risk	Labels	State variations	Special provisions	UN packing group	Excepted quantity	Passenger and cargo aircraft		Cargo aircraft only		
									Packing instruction	Max. net quantity per package	Packing instruction	Max. net quantity per package	
1	2	3	4	5	6	7	8	9	10	11	12	13	
Compressed gas, flammable, n.o.s.*	1954	2.1		Gas flammable	AU 1 CA 7 IR 3 NL 1 US 3	A1			E0	FORBIDDEN	200	150 kg	
Compressed gas, oxidizing, n.o.s.*	3156	2.2	5.1	Gas non-flammable & Oxidizer	US 18				E0	200	75 kg	200	150 kg
Compressed gas, toxic, n.o.s.*	1955	2.3			AU 1 CA 7 IR 3 NL 1 US 3	A2				FORBIDDEN		FORBIDDEN	
Compressed gas, toxic, corrosive, n.o.s.*	3304	2.3	8		AU 1 CA 7 IR 3 NL 1 US 3	A2				FORBIDDEN		FORBIDDEN	
Compressed gas, toxic, flammable, n.o.s.*	1953	2.3	2.1		AU 1 CA 7 IR 3 NL 1 US 3	A2				FORBIDDEN		FORBIDDEN	
Compressed gas, toxic, flammable, corrosive, n.o.s.*	3305	2.3	2.1 8		AU 1 CA 7 IR 3 NL 1 US 3	A2				FORBIDDEN		FORBIDDEN	
Compressed gas, toxic, oxidizing, n.o.s.*	3303	2.3	5.1		AU 1 CA 7 IR 3 NL 1 US 3	A2				FORBIDDEN		FORBIDDEN	
Compressed gas, toxic, oxidizing, corrosive, n.o.s.*	3306	2.3	5.1 8		AU 1 CA 7 IR 3 NL 1 US 3	A2				FORBIDDEN		FORBIDDEN	
Consumer commodity †	8000	9		Miscellaneous		A112				Y963	30 kg G	Y963	30 kg G
Contrivances, water-activated* with burster, expelling charge or propelling charge †	0248	1.2L								FORBIDDEN		FORBIDDEN	
Contrivances, water-activated* with burster, expelling charge or propelling charge †	0249	1.3L								FORBIDDEN		FORBIDDEN	

Name	UN No.	Class or division	Subsidiary risk	Labels	State variations	Special provisions	UN packing group	Excepted quantity	Passenger and cargo aircraft		Cargo aircraft only	
									Packing instruction	Max. net quantity per package	Packing instruction	Max. net quantity per package
1	2	3	4	5	6	7	8	9	10	11	12	13
Copper acetoarsenite	1585	6.1		Toxic	US 4		II	E4	669 Y644	25 kg 1 kg	676	100 kg
Copper acetylide	FORBIDDEN											
Copper amine azide	FORBIDDEN											
Copper arsenite	1586	6.1		Toxic			II	E4	669 Y644	25 kg 1 kg	676	100 kg
Copper (II) arsenite, see Copper arsenite												
Copper based pesticide, liquid, flammable, toxic* , flash point less than 23°C	2776	3	6.1	Liquid flammable & Toxic		A4	I II	E0 E2	FORBIDDEN 352 Y341	1 L 1 L	361 364	30 L 60 L
Copper based pesticide, liquid, toxic*	3010	6.1		Toxic		A3 A4	I II III	E5 E4 E1	652 654 Y641 655 Y642	1 L 5 L 1 L 60 L 2 L	658 662 663	30 L 60 L 220 L
Copper based pesticide, liquid, toxic, flammable* , flash point not less than 23°C	3009	6.1	3	Toxic & Liquid flammable		A3 A4	I II III	E5 E4 E1	652 654 Y641 655 Y642	1 L 5 L 1 L 60 L 2 L	658 662 663	30 L 60 L 220 L
Copper based pesticide, solid, toxic*	2775	6.1		Toxic		A3 A5	I II III	E5 E4 E1	666 669 Y644 670 Y645	5 kg 25 kg 1 kg 100 kg 10 kg	673 676 677	50 kg 100 kg 200 kg
Copper chlorate	2721	5.1		Oxidizer			II	E2	558 Y544	5 kg 2.5 kg	562	25 kg
Copper (II) chlorate, see Copper chlorate												
Copper chloride	2802	8		Corrosive	US 4		III	E1	860 Y845	25 kg 5 kg	864	100 kg
Copper cyanide	1587	6.1		Toxic	US 4		II	E4	669 Y644	25 kg 1 kg	676	100 kg
Copper selenate, see Selenates												
Copper selenite, see Selenites												
Copper tetramine nitrate	FORBIDDEN											

Name	UN No.	Class or division	Subsidiary risk	Labels	State variations	Special provisions	UN packing group	Excepted quantity	Passenger and cargo aircraft		Cargo aircraft only	
									Packing instruction	Max. net quantity per package	Packing instruction	Max. net quantity per package
1	2	3	4	5	6	7	8	9	10	11	12	13
Copra †	1363	4.2			AU 1 CA 7 IR 3 NL 1 US 3	A2			FORBIDDEN		FORBIDDEN	
Cord, detonating, flexible †	0065	1.1D			AU 2 CA 7 IR 3 NL 1 US 3	A2			FORBIDDEN		FORBIDDEN	
Cord, detonating, flexible †	0289	1.4D		Explosive 1.4	AU 1 CA 7 IR 3 NL 1 US 3	A1		E0	FORBIDDEN		139	75 kg
Cord, detonating, metal clad †	0102	1.2D							FORBIDDEN		FORBIDDEN	
Cord, detonating, metal clad †	0290	1.1D							FORBIDDEN		FORBIDDEN	
Cord, detonating, mild effect, metal clad	0104	1.4D		Explosive 1.4				E0	FORBIDDEN		139	75 kg
Cord, igniter †	0066	1.4G		Explosive 1.4	AU 1 CA 7 IR 3 NL 1 US 3	A1		E0	FORBIDDEN		140	75 kg
Cordite, see Powder, smokeless												
Corrosive liquid, n.o.s.*	1760	8		Corrosive		A3	I II III	E0 E2 E1	850 851 Y840 852 Y841	0.5 L 1 L 0.5 L 5 L 1 L	854 855 856	2.5 L 30 L 60 L
Corrosive liquid, acidic, inorganic, n.o.s.*	3264	8		Corrosive		A3	I II III	E0 E2 E1	850 851 Y840 852 Y841	0.5 L 1 L 0.5 L 5 L 1 L	854 855 856	2.5 L 30 L 60 L
Corrosive liquid, acidic, organic, n.o.s.*	3265	8		Corrosive		A3	I II III	E0 E2 E1	850 851 Y840 852 Y841	0.5 L 1 L 0.5 L 5 L 1 L	854 855 856	2.5 L 30 L 60 L

Name	UN No.	Class or division	Subsidiary risk	Labels	State variations	Special provisions	UN packing group	Excepted quantity	Passenger and cargo aircraft		Cargo aircraft only			
									Packing instruction	Max. net quantity per package	Packing instruction	Max. net quantity per package		
1	2	3	4	5	6	7	8	9	10	11	12	13		
Corrosive liquid, basic, inorganic, n.o.s.*	3266	8		Corrosive		A3	I	E0	850	0.5 L	854	2.5 L		
								II	851	1 L		855	30 L	
								Y840	0.5 L					
							III	E1	852	5 L	856	60 L		
								Y841	1 L					
Corrosive liquid, basic, organic, n.o.s.*	3267	8		Corrosive		A3	I	E0	850	0.5 L	854	2.5 L		
								II	851	1 L		855	30 L	
								Y840	0.5 L					
							III	E1	852	5 L	856	60 L		
								Y841	1 L					
Corrosive liquid, flammable, n.o.s.*	2920	8	3	Corrosive & Liquid flammable			I	E0	850	0.5 L	854	2.5 L		
								II	851	1 L		855	30 L	
								Y840	0.5 L					
Corrosive liquid, oxidizing, n.o.s.*	3093	8	5.1	Corrosive & Oxidizer			I	E0	FORBIDDEN		854	2.5 L		
								II	E2	851		1 L	855	30 L
								Y840	0.5 L					
Corrosive liquid, self-heating, n.o.s.*	3301	8	4.2	Corrosive & Spontaneous combustion			I	E0	850	0.5 L	854	2.5 L		
								II	E2	851		1 L	855	30 L
Corrosive liquid, toxic, n.o.s.*	2922	8	6.1	Corrosive & Toxic		A3	I	E0	850	0.5 L	854	2.5 L		
								II	E2	851		1 L	855	30 L
								Y840	0.5 L					
							III	E1	852	5 L	856	60 L		
								Y841	1 L					
Corrosive liquid, water-reactive, n.o.s.*	3094	8	4.3	Corrosive & Danger if wet				E0	FORBIDDEN		FORBIDDEN			
Corrosive solid, n.o.s.*	1759	8		Corrosive		A3	I	E0	858	1 kg	862	25 kg		
								II	E2	859		15 kg	863	50 kg
								Y844	5 kg					
							III	E1	860	25 kg	864	100 kg		
								Y845	5 kg					
Corrosive solid, acidic, inorganic, n.o.s.*	3260	8		Corrosive		A3	I	E0	858	1 kg	862	25 kg		
								II	E2	859		15 kg	863	50 kg
								Y844	5 kg					
							III	E1	860	25 kg	864	100 kg		
								Y845	5 kg					
Corrosive solid, acidic, organic, n.o.s.*	3261	8		Corrosive		A3	I	E0	858	1 kg	862	25 kg		
								II	E2	859		15 kg	863	50 kg
								Y844	5 kg					
							III	E1	860	25 kg	864	100 kg		
								Y845	5 kg					

Name	UN No.	Class or division	Subsidiary risk	Labels	State variations	Special provisions	UN packing group	Excepted quantity	Passenger and cargo aircraft		Cargo aircraft only			
									Packing instruction	Max. net quantity per package	Packing instruction	Max. net quantity per package		
1	2	3	4	5	6	7	8	9	10	11	12	13		
Corrosive solid, basic, inorganic, n.o.s.*	3262	8		Corrosive		A3	I	E0	858	1 kg	862	25 kg		
								E2	859	15 kg		863	50 kg	
								III	E1	860		25 kg	864	100 kg
									Y845	5 kg				
Corrosive solid, basic, organic, n.o.s.*	3263	8		Corrosive		A3	I	E0	858	1 kg	862	25 kg		
								E2	859	15 kg		863	50 kg	
								III	E1	860		25 kg	864	100 kg
									Y845	5 kg				
Corrosive solid, flammable, n.o.s.*	2921	8	4.1	Corrosive & Solid flammable			I	E0	858	1 kg	862	25 kg		
								E2	859	15 kg		863	50 kg	
								Y844	5 kg					
Corrosive solid, oxidizing, n.o.s.*	3084	8	5.1	Corrosive & Oxidizer			I	E0	858	1 kg	862	25 kg		
								E2	859	15 kg		863	50 kg	
								Y844	5 kg					
Corrosive solid, self-heating, n.o.s.*	3095	8	4.2	Corrosive & Spontaneous combustion			I	E0	858	1 kg	862	25 kg		
								E2	859	15 kg		863	50 kg	
Corrosive solid, toxic, n.o.s.*	2923	8	6.1	Corrosive & Toxic		A3	I	E0	858	1 kg	862	25 kg		
								E2	859	15 kg		863	50 kg	
								III	E1	860		25 kg	864	100 kg
									Y845	5 kg				
Corrosive solid, water-reactive, n.o.s.*	3096	8	4.3	Corrosive & Danger if wet			I	E0	858	1 kg	862	25 kg		
								E2	859	15 kg		863	50 kg	
								Y844	5 kg					
Cosmetics, n.o.s., see Consumer commodity														
Cosmetics, corrosive, liquid, n.o.s., see Corrosive liquid, n.o.s.														
Cosmetics, corrosive, solid, n.o.s., see Corrosive solid, n.o.s.														
Cosmetics, flammable, liquid, n.o.s., see Flammable liquid, n.o.s. or Perfumery products														
Cosmetics, flammable, solid, n.o.s., see Flammable solid, inorganic, n.o.s. or organic, n.o.s.														

Name	UN No.	Class or division	Subsidiary risk	Labels	State variations	Special provisions	UN packing group	Excepted quantity	Passenger and cargo aircraft		Cargo aircraft only	
									Packing instruction	Max. net quantity per package	Packing instruction	Max. net quantity per package
1	2	3	4	5	6	7	8	9	10	11	12	13
Cosmetics, oxidizing material, n.o.s., see Oxidizing liquid or solid, n.o.s.												
Cotton waste, oily	1364	4.2			AU 1 CA 7 IR 3 NL 1 US 3	A2			FORBIDDEN		FORBIDDEN	
Cotton, wet	1365	4.2			AU 1 CA 7 IR 3 NL 1 US 3	A2			FORBIDDEN		FORBIDDEN	
Coumarin derivative pesticide, liquid, flammable, toxic* , flash point less than 23°C	3024	3	6.1	Liquid flammable & Toxic		A4	I II	E0 E2	FORBIDDEN 352 Y341	1 L 1 L	361 364	30 L 60 L
Coumarin derivative pesticide, liquid, toxic*	3026	6.1		Toxic		A3 A4	I II III	E5 E4 E1	652 654 Y641 655 Y642	1 L 5 L 1 L 60 L 2 L	658 662 663	30 L 60 L 220 L
Coumarin derivative pesticide, liquid, toxic, flammable* , flash point not less than 23°C	3025	6.1	3	Toxic & Liquid flammable		A3 A4	I II III	E5 E4 E1	652 654 Y641 655 Y642	1 L 5 L 1 L 60 L 2 L	658 662 663	30 L 60 L 220 L
Coumarin derivative pesticide, solid, toxic*	3027	6.1		Toxic		A3 A5	I II III	E5 E4 E1	666 669 Y644 670 Y645	5 kg 25 kg 1 kg 100 kg 10 kg	673 676 677	50 kg 100 kg 200 kg
Creosote, see Toxic liquid, organic, n.o.s.												
Creosote salts, see Naphthalene , etc.												
Cresols, liquid	2076	6.1	8	Toxic & Corrosive			II	E4	653 Y640	1 L 0.5 L	660	30 L
Cresols, solid	3455	6.1	8	Toxic & Corrosive			II	E4	668 Y644	15 kg 1 kg	675	50 kg
Cresylic acid	2022	6.1	8	Toxic & Corrosive			II	E4	653 Y640	1 L 0.5 L	660	30 L

Name	UN No.	Class or division	Subsidiary risk	Labels	State variations	Special provisions	UN packing group	Excepted quantity	Passenger and cargo aircraft		Cargo aircraft only		
									Packing instruction	Max. net quantity per package	Packing instruction	Max. net quantity per package	
									10	11	12	13	
† Crocidolite, see Asbestos, amphibole (UN No. 2212)													
Crotonaldehyde	1143	6.1	3		AU 1 CA 7 IR 3 NL 1 US 3 US 4	A2			FORBIDDEN		FORBIDDEN		
Crotonaldehyde, stabilized	1143	6.1	3		AU 1 CA 7 IR 3 NL 1 US 3 US 4	A2			FORBIDDEN		FORBIDDEN		
Crotonic acid, liquid	3472	8		Corrosive				III	E1	852 Y841	5 L 1 L	856	60 L
Crotonic acid, solid	2823	8		Corrosive				III	E1	860 Y845	25 kg 5 kg	864	100 kg
Crotonic aldehyde, stabilized, see Crotonaldehyde, stabilized													
Crotonylene	1144	3		Liquid flammable				I	E3	351	1 L	361	30 L
Crude naphtha, see Petroleum distillates, n.o.s.													
Cumene, see Isopropylbenzene													
Cupric chlorate, see Copper chlorate (UN No. 2721)													
Cupric cyanide, see Copper cyanide													
Cupriethylenediamine solution	1761	8	6.1	Corrosive & Toxic		A3		II	E2	851 Y840	1 L 0.5 L	855	30 L
								III	E1	852 Y841	5 L 1 L	856	60 L
Cutters, cable, explosive †	0070	1.4S		Explosive 1.4					E0	134	25 kg	134	100 kg
Cyanides, inorganic, solid, n.o.s.*	1588	6.1		Toxic	US 4	A3 A13		I	E5	666	5 kg	673	50 kg
								II	E4	669 Y644	25 kg 1 kg	676	100 kg
								III	E1	670 Y645	100 kg 10 kg	677	200 kg

Name	UN No.	Class or division	Subsidiary risk	Labels	State variations	Special provisions	UN packing group	Excepted quantity	Passenger and cargo aircraft		Cargo aircraft only	
									Packing instruction	Max. net quantity per package	Packing instruction	Max. net quantity per package
1	2	3	4	5	6	7	8	9	10	11	12	13
Cyanide solution, n.o.s.*	1935	6.1		Toxic		A3	I II III	E5 E4 E1	652 654 Y641 655 Y642	1 L 5 L 1 L 60 L 2 L	658 661 663	30 L 60 L 220 L
Cyanides, organic, flammable, toxic, n.o.s., see Nitriles, flammable, toxic, n.o.s.												
Cyanides, organic, toxic, n.o.s., see Nitriles, liquid, toxic, n.o.s. (UN No. 3276) or Nitriles, solid, toxic, n.o.s. (UN No. 3439)												
Cyanides, organic, toxic, flammable, n.o.s., see Nitriles, toxic, flammable, n.o.s.												
Cyanoacetonitrile, see Malononitrile												
Cyanogen	1026	2.3	2.1		AU 1 CA 7 IR 3 NL 1 US 3	A2			FORBIDDEN		FORBIDDEN	
Cyanogen bromide	1889	6.1	8		AU 1 CA 7 IR 3 NL 1 US 3	A2			FORBIDDEN		FORBIDDEN	
Cyanogen chloride, stabilized	1589	2.3	8		AU 1 CA 7 IR 3 NL 1 US 3	A2			FORBIDDEN		FORBIDDEN	
Cyanuric chloride	2670	8		Corrosive			II	E2	859 Y844	15 kg 5 kg	863	50 kg
Cyanuric triazide	FORBIDDEN											
Cyclobutane	2601	2.1		Gas flammable	AU 1 CA 7 IR 3 NL 1 US 3	A1		E0	FORBIDDEN		200	150 kg
Cyclobutyl chloroformate	2744	6.1	3 8	Toxic & Liquid flammable & Corrosive			II	E4	653 Y640	1 L 0.5 L	660	30 L

Name	UN No.	Class or division	Subsidiary risk	Labels	State variations	Special provisions	UN packing group	Excepted quantity	Passenger and cargo aircraft		Cargo aircraft only	
									Packing instruction	Max. net quantity per package	Packing instruction	Max. net quantity per package
1	2	3	4	5	6	7	8	9	10	11	12	13
1,5,9-Cyclododecatriene	2518	6.1		Toxic			III	E1	655 Y642	60 L 2 L	663	220 L
Cycloheptane	2241	3		Liquid flammable			II	E2	353 Y341	5 L 1 L	364	60 L
Cycloheptatriene	2603	3	6.1	Liquid flammable & Toxic			II	E2	352 Y341	1 L 1 L	364	60 L
1,3,5-Cycloheptatriene, see Cycloheptatriene												
Cycloheptene	2242	3		Liquid flammable			II	E2	353 Y341	5 L 1 L	364	60 L
1,4-Cyclohexadienedione, see Benzoquinone												
Cyclohexane	1145	3		Liquid flammable			II	E2	353 Y341	5 L 1 L	364	60 L
Cyclohexanethiol, see Cyclohexyl mercaptan												
Cyclohexanone	1915	3		Liquid flammable			III	E1	355 Y344	60 L 10 L	366	220 L
Cyclohexene	2256	3		Liquid flammable			II	E2	353 Y341	5 L 1 L	364	60 L
Cyclohexenyltrichlorosilane	1762	8		Corrosive	AU 1 CA 7 IR 3 NL 1 US 3	A1	II	E0	FORBIDDEN		876	30 L
Cyclohexyl acetate	2243	3		Liquid flammable			III	E1	355 Y344	60 L 10 L	366	220 L
Cyclohexylamine	2357	8	3	Corrosive & Liquid flammable			II	E2	851 Y840	1 L 0.5 L	855	30 L
Cyclohexyl isocyanate	2488	6.1	3						FORBIDDEN		FORBIDDEN	
Cyclohexyl mercaptan	3054	3		Liquid flammable			III	E1	355 Y344	60 L 10 L	366	220 L
Cyclohexyltrichlorosilane	1763	8		Corrosive	AU 1 CA 7 IR 3 NL 1 US 3	A1	II	E0	FORBIDDEN		876	30 L
Cyclonite and cyclotetramethylene-tetranitramine mixture, desensitized with not less than 10% phlegmatizer, by mass	0391	1.1D							FORBIDDEN		FORBIDDEN	

Name	UN No.	Class or division	Subsidiary risk	Labels	State variations	Special provisions	UN packing group	Excepted quantity	Passenger and cargo aircraft		Cargo aircraft only	
									Packing instruction	Max. net quantity per package	Packing instruction	Max. net quantity per package
1	2	3	4	5	6	7	8	9	10	11	12	13
Cyclonite and cyclotetramethylene-tetranitramine mixture, wetted with not less than 15% water, by mass	0391	1.1D							FORBIDDEN		FORBIDDEN	
Cyclonite, desensitized	0483	1.1D							FORBIDDEN		FORBIDDEN	
Cyclonite, wetted with not less than 15% water, by mass	0072	1.1D							FORBIDDEN		FORBIDDEN	
Cyclooctadiene phosphines	2940	4.2		Spontaneous combustion			II	E2	467	15 kg	470	50 kg
Cyclooctadienes	2520	3		Liquid flammable			III	E1	355 Y344	60 L 10 L	366	220 L
Cyclooctatetraene	2358	3		Liquid flammable			II	E2	353 Y341	5 L 1 L	364	60 L
Cyclopentane	1146	3		Liquid flammable			II	E2	353 Y341	5 L 1 L	364	60 L
Cyclopentanol	2244	3		Liquid flammable			III	E1	355 Y344	60 L 10 L	366	220 L
Cyclopentanone	2245	3		Liquid flammable			III	E1	355 Y344	60 L 10 L	366	220 L
Cyclopentene	2246	3		Liquid flammable			II	E2	353 Y341	5 L 1 L	364	60 L
Cyclopropane	1027	2.1		Gas flammable	AU 1 CA 7 IR 3 NL 1 US 3	A1		E0	FORBIDDEN		200	150 kg
Cyclotetramethylene-tetranitramine, desensitized	0484	1.1D							FORBIDDEN		FORBIDDEN	
Cyclotetramethylenetetranitramine (dry or unphlegmatized) (HMX)									FORBIDDEN			
Cyclotetramethylene-tetranitramine, wetted with not less than 15% water, by mass	0226	1.1D							FORBIDDEN		FORBIDDEN	
Cyclotrimethylenetrinitramine and cyclotetramethylene-tetranitramine mixture, desensitized with not less than 10% phlegmatizer, by mass	0391	1.1D							FORBIDDEN		FORBIDDEN	
Cyclotrimethylenetrinitramine and cyclotetramethylene-tetranitramine mixture, wetted with not less than 15% water, by mass	0391	1.1D							FORBIDDEN		FORBIDDEN	
Cyclotrimethylenetrinitramine, desensitized	0483	1.1D							FORBIDDEN		FORBIDDEN	
Cyclotrimethylenetrinitramine, wetted with not less than 15% water, by mass	0072	1.1D							FORBIDDEN		FORBIDDEN	

Name	UN No.	Class or division	Subsidiary risk	Labels	State variations	Special provisions	UN packing group	Excepted quantity	Passenger and cargo aircraft		Cargo aircraft only	
									Packing instruction	Max. net quantity per package	Packing instruction	Max. net quantity per package
1	2	3	4	5	6	7	8	9	10	11	12	13
Cymenes	2046	3		Liquid flammable			III	E1	355 Y344	60 L 10 L	366	220 L
Cymol, see Cymenes												
D												
Dangerous goods in apparatus	3363	9		Miscellaneous		A48 A107		E0	see 962		see 962	
Dangerous goods in machinery	3363	9		Miscellaneous		A48 A107		E0	see 962		see 962	
Deanol, see 2-Dimethylaminoethanol (UN No. 2051)												
Decaborane	1868	4.1	6.1	Solid flammable & Toxic	AU 1 CA 7 IR 3 NL 1 US 3	A1	II	E0	FORBIDDEN		448	50 kg
Decahydronaphthalene	1147	3		Liquid flammable			III	E1	355 Y344	60 L 10 L	366	220 L
Decalin, see Decahydronaphthalene												
n-Decane	2247	3		Liquid flammable			III	E1	355 Y344	60 L 10 L	366	220 L
Deflagrating metal salts of aromatic nitro-derivatives, n.o.s.	0132	1.3C							FORBIDDEN		FORBIDDEN	
Depth charges, see Charges, depth												
Desensitized explosive, liquid, n.o.s.*	3379	3			BE 3	A133			FORBIDDEN		FORBIDDEN	
Desensitized explosive, solid, n.o.s.*	3380	4.1			BE 3	A133			FORBIDDEN		FORBIDDEN	
Detonating relays, see Detonators, non-electric or Detonator assemblies, non-electric												
Detonator assemblies, non-electric for blasting †	0360	1.1B							FORBIDDEN		FORBIDDEN	
Detonator assemblies, non-electric for blasting †	0361	1.4B		Explosive 1.4				E0	FORBIDDEN		131	75 kg
Detonator assemblies, non-electric for blasting †	0500	1.4S		Explosive 1.4		A165		E0	131	25 kg	131	100 kg
Detonators, electric for blasting †	0030	1.1B							FORBIDDEN		FORBIDDEN	
Detonators, electric for blasting †	0255	1.4B		Explosive 1.4				E0	FORBIDDEN		131	75 kg

Name	UN No.	Class or division	Subsidiary risk	Labels	State variations	Special provisions	UN packing group	Excepted quantity	Passenger and cargo aircraft		Cargo aircraft only	
									Packing instruction	Max. net quantity per package	Packing instruction	Max. net quantity per package
1	2	3	4	5	6	7	8	9	10	11	12	13
Detonators, electric for blasting †	0456	1.4S		Explosive 1.4		A165		E0	131	25 kg	131	100 kg
Detonators for ammunition †	0073	1.1B							FORBIDDEN		FORBIDDEN	
Detonators for ammunition †	0364	1.2B							FORBIDDEN		FORBIDDEN	
Detonators for ammunition †	0365	1.4B		Explosive 1.4				E0	FORBIDDEN		133	75 kg
Detonators for ammunition †	0366	1.4S		Explosive 1.4		A165		E0	133	25 kg	133	100 kg
Detonators, non-electric for blasting †	0029	1.1B							FORBIDDEN		FORBIDDEN	
Detonators, non-electric for blasting †	0267	1.4B		Explosive 1.4				E0	FORBIDDEN		131	75 kg
Detonators, non-electric for blasting †	0455	1.4S		Explosive 1.4		A165		E0	131	25 kg	131	100 kg
Deuterium, compressed	1957	2.1		Gas flammable	AU 1 CA 7 IR 3 NL 1 US 3	A1		E0	FORBIDDEN		200	150 kg
Devices, small, hydrocarbon gas powered with release device	3150	2.1		Gas flammable				E0	201	1 kg	201	15 kg
Diacetone alcohol	1148	3		Liquid flammable		A3	II	E2	353 Y341	5 L 1 L	364	60 L
							III	E1	355 Y344	60 L 10 L	366	220 L
Diacetone alcohol peroxides, more than 57% in solution with more than 9% hydrogen peroxide, less than 26% diacetone alcohol and less than 9% water; total active oxygen content more than 10% by mass	FORBIDDEN											
Diallylamine	2359	3	6.1 8	Liquid flammable & Toxic & Corrosive			II	E2	352 Y340	1 L 0.5 L	363	5 L
Diallyl ether	2360	3	6.1	Liquid flammable & Toxic			II	E2	352 Y341	1 L 1 L	364	60 L
4,4'-Diaminodiphenylmethane	2651	6.1		Toxic			III	E1	670 Y645	100 kg 10 kg	677	200 kg
1,2-Diaminoethane, see Ethylenediamine												
Diaminopropylamine, see 3,3'-Iminodipropylamine												

Name	UN No.	Class or division	Subsidiary risk	Labels	State variations	Special provisions	UN packing group	Excepted quantity	Passenger and cargo aircraft		Cargo aircraft only	
									Packing instruction	Max. net quantity per package	Packing instruction	Max. net quantity per package
1	2	3	4	5	6	7	8	9	10	11	12	13
Di-n-amylamine	2841	3	6.1	Liquid flammable & Toxic			III	E1	355 Y343	60 L 2 L	366	220 L
p-Diazidobenzene	FORBIDDEN											
1,2-Diazidoethane	FORBIDDEN											
1,1'-Diazoaminonaphthalene	FORBIDDEN											
Diazoaminotetrazole (dry)	FORBIDDEN											
Diazodinitrophenol (dry)	FORBIDDEN											
Diazodinitrophenol, wetted with not less than 40% water, or mixture of alcohol and water, by mass	0074	1.1A							FORBIDDEN		FORBIDDEN	
Diazodiphenylmethane	FORBIDDEN											
2-Diazo-1-naphthol-4-sulphonylchloride	FORBIDDEN											
2-Diazo-1-naphthol-5-sulphonylchloride	FORBIDDEN											
Diazonium nitrates (dry)	FORBIDDEN											
Diazonium perchlorates (dry)	FORBIDDEN											
1,3-Diazopropane	FORBIDDEN											
Dibenzopyridine, see Acridine												
Dibenzoyl peroxide, more than 77% and not more than 94%, when with 6% or more water	FORBIDDEN											
Dibenzoyl peroxide, more than 51%, when with not more than 48% inert solid	FORBIDDEN											
Dibenzylchlorosilane	2434	8		Corrosive	AU 1 CA 7 IR 3 NL 1 US 3	A1	II	E0	FORBIDDEN		876	30 L

Name	UN No.	Class or division	Subsidiary risk	Labels	State variations	Special provisions	UN packing group	Excepted quantity	Passenger and cargo aircraft		Cargo aircraft only	
									Packing instruction	Max. net quantity per package	Packing instruction	Max. net quantity per package
1	2	3	4	5	6	7	8	9	10	11	12	13
Dibenzyl peroxydicarbonate, more than 87% with water	FORBIDDEN											
Dibenzyl peroxydicarbonate, not more than 87% when with 13% or more water	FORBIDDEN											
Diborane	1911	2.3	2.1		AU 1 CA 7 IR 3 NL 1 US 3	A2			FORBIDDEN		FORBIDDEN	
Dibromoacetylene	FORBIDDEN											
1,2-Dibromobutan-3-one	2648	6.1		Toxic			II	E4	654 Y641	5 L 1 L	662	60 L
1,2-Dibromo-3-chloropropane, see Dibromochloropropanes												
Dibromochloropropanes	2872	6.1		Toxic	US 4	A3	II	E4	654 Y641	5 L 1 L	662	60 L
							III	E1	655 Y642	60 L 2 L	663	220 L
Dibromodifluoromethane	1941	9		Miscellaneous			III	E1	964 Y964	100 L 30 kg G	964	220 L
Dibromomethane	2664	6.1		Toxic			III	E1	655 Y642	60 L 2 L	663	220 L
Di-n-butylamine	2248	8	3	Corrosive & Liquid flammable			II	E2	851 Y840	1 L 0.5 L	855	30 L
Dibutylaminoethanol	2873	6.1		Toxic			III	E1	655 Y642	60 L 2 L	663	220 L
2-Dibutylaminoethanol, see Dibutylaminoethanol												
N,N-Di-n-butylaminoethanol, see Dibutylaminoethanol												
Dibutyl ethers	1149	3		Liquid flammable			III	E1	355 Y344	60 L 10 L	366	220 L
1,1-Di-(tert-butylperoxy)-3,3,5-trimethylcyclohexane, more than 90%	FORBIDDEN											
2,2-Di-(tert-butylperoxy) butane, more than 55% in solution	FORBIDDEN											

Name	UN No.	Class or division	Subsidiary risk	Labels	State variations	Special provisions	UN packing group	Excepted quantity	Passenger and cargo aircraft		Cargo aircraft only	
									Packing instruction	Max. net quantity per package	Packing instruction	Max. net quantity per package
1	2	3	4	5	6	7	8	9	10	11	12	13
1,1-Di-(tert-butylperoxy) cyclohexane, more than 80%	FORBIDDEN											
Di-n-butyl peroxydicarbonate, more than 52% in solution	FORBIDDEN											
Di-(tert-butylperoxy) phthalate, more than 55% in solution	FORBIDDEN											
N,N'-Dichlorazodicarbonimidine (salts of) (dry)	FORBIDDEN											
Dichloroacetic acid	1764	8		Corrosive			II	E2	851 Y840	1 L 0.5 L	855	30 L
1,3-Dichloroacetone	2649	6.1		Toxic			II	E4	669 Y644	25 kg 1 kg	676	100 kg
Dichloroacetyl chloride	1765	8		Corrosive			II	E2	851 Y840	1 L 0.5 L	855	30 L
Dichloroacetylene	FORBIDDEN											
Dichloroanilines, liquid	1590	6.1		Toxic		A113	II	E4	654 Y641	5 L 1 L	662	60 L
Dichloroanilines, solid	3442	6.1		Toxic		A113	II	E4	669 Y644	25 kg 1 kg	676	100 kg
o-Dichlorobenzene	1591	6.1		Toxic	US 4	A113	III	E1	655 Y642	60 L 2 L	663	220 L
Di-4-chlorobenzoyl peroxide, not more than 77%, when with 23% or more water	FORBIDDEN											
2,2'-Dichlorodiethyl ether	1916	6.1	3	Toxic & Liquid flammable	US 4		II	E4	654 Y641	5 L 1 L	661	60 L
Dichlorodifluoromethane	1028	2.2		Gas non-flammable				E1	200	75 kg	200	150 kg
Dichlorodifluoromethane and difluoroethane azeotropic mixture with approximately 74% dichlorodifluoromethane	2602	2.2		Gas non-flammable				E1	200	75 kg	200	150 kg
Dichlorodifluoromethane and ethylene oxide mixture, see Ethylene oxide and dichlorodifluoromethane mixture , etc.												
Dichlorodimethyl ether, symmetrical	2249	6.1	3						FORBIDDEN		FORBIDDEN	
1,1-Dichloroethane	2362	3		Liquid flammable	US 4		II	E2	353 Y341	5 L 1 L	364	60 L

Name	UN No.	Class or division	Subsidiary risk	Labels	State variations	Special provisions	UN packing group	Excepted quantity	Passenger and cargo aircraft		Cargo aircraft only	
									Packing instruction	Max. net quantity per package	Packing instruction	Max. net quantity per package
1	2	3	4	5	6	7	8	9	10	11	12	13
1,2-Dichloroethane, see Ethylene dichloride												
1,2-Dichloroethylene	1150	3		Liquid flammable	US 4		II	E2	353 Y341	5 L 1 L	364	60 L
Di(2-chloroethyl) ether, see 2,2'-Dichlorodiethyl ether												
Dichloroethyl sulphide	FORBIDDEN											
Dichlorofluoromethane	1029	2.2		Gas non-flammable				E1	200	75 kg	200	150 kg
alpha-Dichlorohydrin, see 1,3-Dichloropropanol-2												
Dichloroisocyanuric acid, dry	2465	5.1		Oxidizer		A28	II	E2	558 Y544	5 kg 2.5 kg	562	25 kg
Dichloroisocyanuric acid salts	2465	5.1		Oxidizer		A28	II	E2	558 Y544	5 kg 2.5 kg	562	25 kg
Dichloroisopropyl ether	2490	6.1		Toxic			II	E4	654 Y641	5 L 1 L	662	60 L
Dichloromethane	1593	6.1		Toxic			III	E1	655 Y642	60 L 2 L	663	220 L
1,1-Dichloro-1-nitroethane	2650	6.1		Toxic			II	E4	654 Y641	5 L 1 L	662	60 L
Dichloropentanes	1152	3		Liquid flammable			III	E1	355 Y344	60 L 10 L	366	220 L
Dichlorophenol, see Chlorophenols , liquid or solid, etc.												
Dichlorophenyl isocyanates	2250	6.1		Toxic			II	E4	669 Y644	25 kg 1 kg	676	100 kg
Dichlorophenyltrichlorosilane	1766	8		Corrosive	AU 1 CA 7 IR 3 NL 1 US 3	A1	II	E0	FORBIDDEN		876	30 L
1,2-Dichloropropane	1279	3		Liquid flammable			II	E2	353 Y341	5 L 1 L	364	60 L
1,3-Dichloropropanol-2	2750	6.1		Toxic			II	E4	654 Y641	5 L 1 L	662	60 L
1,3-Dichloro-2-propanone, see 1,3-Dichloroacetone												

Name	UN No.	Class or division	Subsidiary risk	Labels	State variations	Special provisions	UN packing group	Excepted quantity	Passenger and cargo aircraft		Cargo aircraft only	
									Packing instruction	Max. net quantity per package	Packing instruction	Max. net quantity per package
1	2	3	4	5	6	7	8	9	10	11	12	13
Dichloropropenes	2047	3		Liquid flammable	US 4	A3	II	E2	353 Y341	5 L 1 L	364	60 L
							III	E1	355 Y344	60 L 10 L	366	220 L
Dichlorosilane	2189	2.3	2.1 8		AU 1 CA 7 IR 3 NL 1 US 3	A2			FORBIDDEN		FORBIDDEN	
Dichloro-s-triazine -2,4,6-trione, see Dichloroisocyanuric acid, dry or Dichloroisocyanuric acid, salts												
1,2-Dichloro-1,1,2,2-tetrafluoroethane	1958	2.2		Gas non-flammable				E1	200	75 kg	200	150 kg
Dichlorovinylchloroarsine	FORBIDDEN											
1,4-Dicyanobutane, see Adiponitrile												
Dicycloheptadiene, see Bicyclo [2.2.1] hepta-2,5-diene, stabilized or 2.5-Nonbornadiene, stabilized												
Dicyclohexylamine	2565	8		Corrosive			III	E1	852 Y841	5 L 1 L	856	60 L
Dicyclohexylamine nitrite, see Dicyclohexylammonium nitrite												
Dicyclohexylammonium nitrite	2687	4.1		Solid flammable			III	E1	446 Y443	25 kg 10 kg	449	100 kg
Dicyclohexyl peroxydicarbonate, more than 91%	FORBIDDEN											
Dicyclopentadiene	2048	3		Liquid flammable			III	E1	355 Y344	60 L 10 L	366	220 L
2,2-Di-(4,4-di-tert-butylperoxy-cyclohexyl) propane, more than 42% with inert solid	FORBIDDEN											
Di-2,4-dichlorobenzoyl peroxide, not more than 77% when with 23% or more water	FORBIDDEN											
1,2-Di-(dimethylamino) ethane	2372	3		Liquid flammable			II	E2	353 Y341	5 L 1 L	364	60 L
Didymium nitrate	1465	5.1		Oxidizer			III	E1	559 Y546	25 kg 10 kg	563	100 kg

Name	UN No.	Class or division	Subsidiary risk	Labels	State variations	Special provisions	UN packing group	Excepted quantity	Passenger and cargo aircraft		Cargo aircraft only	
									Packing instruction	Max. net quantity per package	Packing instruction	Max. net quantity per package
1	2	3	4	5	6	7	8	9	10	11	12	13
Diesel fuel	1202	3		Liquid flammable		A3	III	E1	355 Y344	60 L 10 L	366	220 L
Diethanol nitrosamine dinitrate (dry)	FORBIDDEN											
1,1-Diethoxyethane, see Acetal												
1,2-Diethoxyethane, see Ethylene glycol diethyl ether												
Diethoxymethane	2373	3		Liquid flammable			II	E2	353 Y341	5 L 1 L	364	60 L
3,3-Diethoxypropene	2374	3		Liquid flammable			II	E2	353 Y341	5 L 1 L	364	60 L
Diethylamine	1154	3	8	Liquid flammable & Corrosive	US 4		II	E2	352 Y340	1 L 0.5 L	363	5 L
Diethylaminoethanol, see 2-Diethylaminoethanol (UN. 2686)												
2-Diethylaminoethanol	2686	8	3	Corrosive & Liquid flammable			II	E2	851 Y840	1 L 0.5 L	855	30 L
3-Diethylaminopropylamine	2684	3	8	Liquid flammable & Corrosive			III	E1	354 Y342	5 L 1 L	365	60 L
N,N-Diethylaniline	2432	6.1		Toxic		A113	III	E1	655 Y642	60 L 2 L	663	220 L
Diethylbenzene	2049	3		Liquid flammable			III	E1	355 Y344	60 L 10 L	366	220 L
Diethylcarbinol, see Pentanols (UN No. 1105)												
Diethyl carbonate	2366	3		Liquid flammable			III	E1	355 Y344	60 L 10 L	366	220 L
Diethyldichlorosilane	1767	8	3	Corrosive & Liquid flammable	AU 1 CA 7 IR 3 NL 1 US 3	A1	II	E0	FORBIDDEN		876	30 L
Diethylenediamine, see Piperazine												
Diethyleneglycol dinitrate, desensitized with not less than 25% non-volatile, water-insoluble phlegmatizer, by mass	0075	1.1D							FORBIDDEN		FORBIDDEN	
Diethyleneglycol dinitrate (dry)	FORBIDDEN											

Name	UN No.	Class or division	Subsidiary risk	Labels	State variations	Special provisions	UN packing group	Excepted quantity	Passenger and cargo aircraft		Cargo aircraft only	
									Packing instruction	Max. net quantity per package	Packing instruction	Max. net quantity per package
1	2	3	4	5	6	7	8	9	10	11	12	13
Diethylenetriamine	2079	8		Corrosive			II	E2	851 Y840	1 L 0.5 L	855	30 L
N,N-Diethylethanolamine, see 2-Diethylaminoethanol												
Diethyl ether	1155	3		Liquid flammable			I	E3	351	1 L	361	30 L
N,N-Diethylethylenediamine	2685	8	3	Corrosive & Liquid flammable			II	E2	851 Y840	1 L 0.5 L	855	30 L
Diethylgold bromide	FORBIDDEN											
Di-(2-ethylhexyl) phosphoric acid, see Diisooctyl acid phosphate												
Diethyl ketone	1156	3		Liquid flammable			II	E2	353 Y341	5 L 1 L	364	60 L
Diethyl peroxydicarbonate, more than 27% in solution	FORBIDDEN											
Diethyl sulphate	1594	6.1		Toxic			II	E4	654 Y641	5 L 1 L	662	60 L
Diethyl sulphide	2375	3		Liquid flammable			II	E2	353 Y341	5 L 1 L	364	60 L
Diethylthiophosphoryl chloride	2751	8		Corrosive			II	E2	851 Y840	1 L 0.5 L	855	30 L
Diethylzinc, see Organometallic substance, liquid, pyrophoric, water-reactive (UN No. 3394)												
2,4-Difluoroaniline, see Fluoroanilines												
Difluorochloroethane, see 1-Chloro-1,1-difluoroethane												
1,1-Difluoroethane	1030	2.1		Gas flammable	AU 1 CA 7 IR 3 NL 1 US 3	A1		E0	FORBIDDEN		200	150 kg
1,1-Difluoroethylene	1959	2.1		Gas flammable	AU 1 CA 7 IR 3 NL 1 US 3	A1		E0	FORBIDDEN		200	150 kg

Name	UN No.	Class or division	Subsidiary risk	Labels	State variations	Special provisions	UN packing group	Excepted quantity	Passenger and cargo aircraft		Cargo aircraft only	
									Packing instruction	Max. net quantity per package	Packing instruction	Max. net quantity per package
1	2	3	4	5	6	7	8	9	10	11	12	13
Difluoromethane	3252	2.1		Gas flammable	AU 1 CA 7 IR 3 NL 1 US 3	A1		E0	FORBIDDEN		200	150 kg
Difluoromethane, pentafluoroethane, and 1,1,1,2-tetrafluoroethane azeotropic mixture with approximately 23% difluoromethane and 25% pentafluoroethane, see Refrigerant gas R 407C												
Difluoromethane, pentafluoroethane, and 1,1,1,2-tetrafluoroethane azeotropic mixture with approximately 20% difluoromethane and 40% pentafluoroethane, see Refrigerant gas R 407A												
Difluoromethane, pentafluoroethane, and 1,1,1,2-tetrafluoroethane azeotropic mixture with approximately 10% difluoromethane and 70% pentafluoroethane, see Refrigerant gas R 407B												
Difluorophosphoric acid, anhydrous	1768	8		Corrosive			II	E2	851 Y840	1 L 0.5 L	855	30 L
2,2-Dihydroperoxypropane, not more than 27% when with 73% or more inert solid									FORBIDDEN			
2,3-Dihydropyran	2376	3		Liquid flammable			II	E2	353 Y341	5 L 1 L	364	60 L
1,8-Dihydroxy-2,4,5,7-tetranitro-anthraquinone (chrysammic acid)									FORBIDDEN			
Di-(1-hydroxytetrazole) (dry)									FORBIDDEN			
Diiodoacetylene									FORBIDDEN			
Diisobutylamine	2361	3	8	Liquid flammable & Corrosive			III	E1	354 Y342	5 L 1 L	365	60 L
alpha-Diisobutylene, see Diisobutylene, isomeric compounds												
beta-Diisobutylene, see Diisobutylene, isomeric compounds												

Name	UN No.	Class or division	Subsidiary risk	Labels	State variations	Special provisions	UN packing group	Excepted quantity	Passenger and cargo aircraft		Cargo aircraft only	
									Packing instruction	Max. net quantity per package	Packing instruction	Max. net quantity per package
1	2	3	4	5	6	7	8	9	10	11	12	13
Diisobutylene, isomeric compounds	2050	3		Liquid flammable			II	E2	353 Y341	5 L 1 L	364	60 L
Diisobutyl ketone	1157	3		Liquid flammable			III	E1	355 Y344	60 L 10 L	366	220 L
Diisobutyl peroxide, more than 32% and not more than 52%, when with 48% or more diluent Type A or B	FORBIDDEN											
Diisooctyl acid phosphate	1902	8		Corrosive			III	E1	852 Y841	5 L 1 L	856	60 L
Diisopropylamine	1158	3	8	Liquid flammable & Corrosive			II	E2	352 Y340	1 L 0.5 L	363	5 L
Diisopropyl ether	1159	3		Liquid flammable			II	E2	353 Y341	5 L 1 L	364	60 L
Diisopropyl peroxydicarbonate, more than 52%	FORBIDDEN											
Diketene, stabilized	2521	6.1	3						FORBIDDEN		FORBIDDEN	
1,2-Dimethoxyethane	2252	3		Liquid flammable			II	E2	353 Y341	5 L 1 L	364	60 L
1,1-Dimethoxyethane	2377	3		Liquid flammable			II	E2	353 Y341	5 L 1 L	364	60 L
Dimethoxystrychnine, see Brucine												
Dimethylamine, anhydrous	1032	2.1		Gas flammable	AU 1 CA 7 IR 3 NL 1 US 3	A1		E0	FORBIDDEN		200	150 kg
Dimethylamine, aqueous solution	1160	3	8	Liquid flammable & Corrosive			II	E2	352 Y340	1 L 0.5 L	363	5 L
2-Dimethylaminoacetonitrile	2378	3	6.1	Liquid flammable & Toxic			II	E2	352 Y341	1 L 1 L	364	60 L
2-Dimethylaminoethanol	2051	8	3	Corrosive & Liquid flammable			II	E2	851 Y840	1 L 0.5 L	855	30 L
2-Dimethylaminoethyl acrylate	3302	6.1		Toxic			II	E4	654 Y641	5 L 1 L	662	60 L
2-Dimethylaminoethyl methacrylate	2522	6.1		Toxic			II	E4	654 Y641	5 L 1 L	662	60 L
N,N-Dimethylaniline	2253	6.1		Toxic			II	E4	654 Y641	5 L 1 L	662	60 L

Name	UN No.	Class or division	Subsidiary risk	Labels	State variations	Special provisions	UN packing group	Excepted quantity	Passenger and cargo aircraft		Cargo aircraft only	
									Packing instruction	Max. net quantity per package	Packing instruction	Max. net quantity per package
1	2	3	4	5	6	7	8	9	10	11	12	13
Dimethylarsenic acid, see Cacodylic acid												
Di-(2-methylbenzoyl) peroxide, not more than 87% when with 13% or more water	FORBIDDEN											
N,N-Dimethylbenzylamine, see Benzyl dimethylamine												
2,3-Dimethylbutane	2457	3		Liquid flammable			II	E2	353 Y341	5 L 1 L	364	60 L
1,3-Dimethylbutylamine	2379	3	8	Liquid flammable & Corrosive			II	E2	352 Y340	1 L 0.5 L	363	5 L
Dimethylcarbamoyl chloride	2262	8		Corrosive	US 4		II	E2	851 Y840	1 L 0.5 L	855	30 L
Dimethyl carbonate	1161	3		Liquid flammable			II	E2	353 Y341	5 L 1 L	364	60 L
Dimethylcyclohexanes	2263	3		Liquid flammable			II	E2	353 Y341	5 L 1 L	364	60 L
N,N-Dimethylcyclohexylamine	2264	8	3	Corrosive & Liquid flammable			II	E2	851 Y840	1 L 0.5 L	855	30 L
2,5-Dimethyl-2,5-di-(benzoylperoxy) hexane, more than 82%	FORBIDDEN											
2,5-Dimethyl-2,5-di-(tert-butylperoxy)hexyne-3, more than 86%	FORBIDDEN											
Dimethyldichlorosilane	1162	3	8	Liquid flammable & Corrosive			II	E0	FORBIDDEN		377	5 L
Dimethyldiethoxysilane	2380	3		Liquid flammable			II	E2	353 Y341	5 L 1 L	364	60 L
2,5-Dimethyl-2,5-dihydroperoxy hexane, more than 82% with water	FORBIDDEN											
Dimethyldioxanes	2707	3		Liquid flammable		A3	II	E2	353 Y341	5 L 1 L	364	60 L
							III	E1	355 Y344	60 L 10 L	366	220 L
Dimethyl disulphide	2381	3	6.1				II	E0	FORBIDDEN		FORBIDDEN	
Dimethylethanolamine, see 2-Dimethylaminoethanol												

Name	UN No.	Class or division	Subsidiary risk	Labels	State variations	Special provisions	UN packing group	Excepted quantity	Passenger and cargo aircraft		Cargo aircraft only	
									Packing instruction	Max. net quantity per package	Packing instruction	Max. net quantity per package
1	2	3	4	5	6	7	8	9	10	11	12	13
Dimethyl ether	1033	2.1		Gas flammable	AU 1 CA 7 IR 3 NL 1 US 3	A1		E0	FORBIDDEN		200	150 kg
N,N-Dimethylformamide	2265	3		Liquid flammable			III	E1	355 Y344	60 L 10 L	366	220 L
1,1-Dimethylhydrazine, see Dimethylhydrazine, unsymmetrical												
Dimethylhydrazine, symmetrical	2382	6.1	3		US 4				FORBIDDEN		FORBIDDEN	
Dimethylhydrazine, unsymmetrical	1163	6.1	3 8						FORBIDDEN		FORBIDDEN	
N,N-Dimethyl-4-nitrosoaniline, see p-Nitrosodimethylaniline												
2,2-Dimethylpropane	2044	2.1		Gas flammable	AU 1 CA 7 IR 3 NL 1 US 3	A1		E0	FORBIDDEN		200	150 kg
Dimethyl-N-propylamine	2266	3	8	Liquid flammable & Corrosive			II	E2	352 Y340	1 L 0.5 L	363	5 L
Dimethyl sulphate	1595	6.1	8						FORBIDDEN		FORBIDDEN	
Dimethyl sulphide	1164	3		Liquid flammable			II	E2	353 Y341	5 L 1 L	364	60 L
Dimethyl thiophosphoryl chloride	2267	6.1	8	Toxic & Corrosive			II	E4	653 Y640	1 L 0.5 L	660	30 L
Dimethylzinc, see Organometallic substance, liquid, pyrophoric, water-reactive (UN No. 3394)												
Di-(1-naphthoyl) peroxide	FORBIDDEN											
DINGU	0489	1.1D							FORBIDDEN		FORBIDDEN	
Dinitroanilines	1596	6.1		Toxic			II	E4	669 Y644	25 kg 1 kg	676	100 kg
Dinitrobenzenes, liquid	1597	6.1		Toxic	US 4	A3	II	E4	654 Y641	5 L 1L	662	60 L
							III	E1	655 Y642	60 L 2 L	663	220 L
Dinitrobenzenes, solid	3443	6.1		Toxic			II	E4	669 Y644	25 kg 1 kg	676	100 kg

Name	UN No.	Class or division	Subsidiary risk	Labels	State variations	Special provisions	UN packing group	Excepted quantity	Passenger and cargo aircraft		Cargo aircraft only	
									Packing instruction	Max. net quantity per package	Packing instruction	Max. net quantity per package
1	2	3	4	5	6	7	8	9	10	11	12	13
Dinitrochlorobenzenes, see Chlorodinitrobenzenes, liquid (UN No. 1577) or Chlorodinitrobenzenes, solid (UN No. 3441)												
Dinitro-o-cresol	1598	6.1		Toxic	US 4	A6	II	E4	669 Y644	25 kg 1 kg	676	100 kg
Dinitro-7,8-dimethylglycoluril (dry)	FORBIDDEN											
1,3-Dinitro-5,5-dimethyl hydantoin	FORBIDDEN											
1,3-Dinitro-4,5-dinitrosobenzene	FORBIDDEN											
1,2-Dinitroethane	FORBIDDEN											
1,1-Dinitroethane (dry)	FORBIDDEN											
Dinitrogen tetroxide	1067	2.3	5.1 8		AU 1 CA 7 IR 3 NL 1 US 3	A2			FORBIDDEN		FORBIDDEN	
Dinitroglycoluril	0489	1.1D							FORBIDDEN		FORBIDDEN	
Dinitromethane	FORBIDDEN											
Dinitrophenol , dry or wetted with less than 15% water, by mass	0076	1.1D	6.1						FORBIDDEN		FORBIDDEN	
Dinitrophenolates , alkali metals, dry or wetted with less than 15% water, by mass	0077	1.3C	6.1						FORBIDDEN		FORBIDDEN	
Dinitrophenolates , wetted with not less than 15% water, by mass	1321	4.1	6.1	Solid flammable & Toxic	BE 3	A40	I	E0	451	1 kg	451	15 kg
Dinitrophenol solution	1599	6.1		Toxic	US 4	A3	II III	E4 E1	654 Y641 655 Y642	5 L 1 L 60 L 2 L	662 663	60 L 220 L
Dinitrophenol , wetted with not less than 15% water, by mass	1320	4.1	6.1	Solid flammable & Toxic	BE 3 US 4	A40	I	E0	451	1 kg	451	15 kg
Dinitropropylene glycol	FORBIDDEN											
Dinitroresorcinol , dry or wetted with less than 15% water, by mass	0078	1.1D							FORBIDDEN		FORBIDDEN	

Name	UN No.	Class or division	Subsidiary risk	Labels	State variations	Special provisions	UN packing group	Excepted quantity	Passenger and cargo aircraft		Cargo aircraft only	
									Packing instruction	Max. net quantity per package	Packing instruction	Max. net quantity per package
1	2	3	4	5	6	7	8	9	10	11	12	13
2,4-Dinitroresorcinol (heavy metal salts of) (dry)		FORBIDDEN										
4,6-Dinitroresorcinol (heavy metal salts of) (dry)		FORBIDDEN										
Dinitroresorcinol, wetted with not less than 15% water, by mass	1322	4.1		Solid flammable	BE 3	A40	I	E0	451	1 kg	451	15 kg
3,5-Dinitrosalicylic acid (lead salt) (dry)		FORBIDDEN										
Dinitrosobenzene	0406	1.3C							FORBIDDEN		FORBIDDEN	
Dinitrosobenzylamidine and salts of (dry)		FORBIDDEN										
2,2-Dinitrostilbene		FORBIDDEN										
1,4-Dinitro-1,1,4,4-tetramethylolbutane tetranitrate (dry)		FORBIDDEN										
Dinitrotoluene mixed with sodium chlorate, see Explosive, blasting, type C												
Dinitrotoluenes, liquid	2038	6.1		Toxic	US 4		II	E4	654 Y641	5 L 1 L	662	60 L
Dinitrotoluenes, molten	1600	6.1							FORBIDDEN		FORBIDDEN	
Dinitrotoluenes, solid	3454	6.1		Toxic	US 4		II	E4	669 Y644	25 kg 1 kg	676	100 kg
2,4-Dinitro-1,3,5-trimethylbenzene		FORBIDDEN										
Di-(beta-nitroxyethyl) ammonium nitrate		FORBIDDEN										
a,a'-Di-(nitroxy) methylether		FORBIDDEN										
1,9-Dinitroxy pentamethylene-2,4,6,8-tetramine (dry)		FORBIDDEN										
Dioxane	1165	3		Liquid flammable	US 4		II	E2	353 Y341	5 L 1 L	364	60 L
Dioxolane	1166	3		Liquid flammable			II	E2	353 Y341	5 L 1 L	364	60 L
Dipentene	2052	3		Liquid flammable			III	E1	355 Y344	60 L 10 L	366	220 L

Name	UN No.	Class or division	Subsidiary risk	Labels	State variations	Special provisions	UN packing group	Excepted quantity	Passenger and cargo aircraft		Cargo aircraft only	
									Packing instruction	Max. net quantity per package	Packing instruction	Max. net quantity per package
1	2	3	4	5	6	7	8	9	10	11	12	13
Di-(2-phenoxyethyl) peroxydicarbonate, more than 85%	FORBIDDEN											
Diphenylamine chloroarsine	1698	6.1							FORBIDDEN		FORBIDDEN	
Diphenylchloroarsine, liquid	1699	6.1							FORBIDDEN		FORBIDDEN	
Diphenylchloroarsine, solid	3450	6.1		Toxic			I	E0	FORBIDDEN		673	50 kg
Diphenyldichlorosilane	1769	8		Corrosive	AU 1 CA 7 IR 3 NL 1 US 3	A1	II	E0	FORBIDDEN		876	30 L
Diphenylmethyl bromide	1770	8		Corrosive			II	E2	859 Y844	15 kg 5 kg	863	50 kg
Dipicrylamine	0079	1.1D							FORBIDDEN		FORBIDDEN	
Dipicryl sulphide , dry or wetted with less than 10% water, by mass	0401	1.1D							FORBIDDEN		FORBIDDEN	
Dipicryl sulphide , wetted with not less than 10% water, by mass	2852	4.1		Solid flammable	BE 3	A40	I	E0	FORBIDDEN		451	0.5 kg
Dipropionyl peroxide, more than 28% in solution	FORBIDDEN											
Dipropylamine	2383	3	8	Liquid flammable & Corrosive			II	E2	352 Y340	1 L 0.5 L	363	5 L
Dipropylene triamine, see 3,3'-Iminodipropylamine												
Di-n-propyl ether	2384	3		Liquid flammable			II	E2	353 Y341	5 L 1 L	364	60 L
Dipropyl ketone	2710	3		Liquid flammable			III	E1	355 Y344	60 L 10 L	366	220 L
Disinfectant, liquid, corrosive, n.o.s.*	1903	8		Corrosive		A3	I II III	E0 E2 E1	850 851 Y840 852 Y841	0.5 L 1 L 0.5 L 5 L 1 L	854 855 856	2.5 L 30 L 60 L
Disinfectant, liquid, toxic, n.o.s.*	3142	6.1		Toxic		A3 A4	I II III	E5 E4 E1	652 654 Y641 655 Y642	1 L 5 L 1 L 60 L 2 L	658 662 663	30 L 60 L 220 L

Name	UN No.	Class or division	Subsidiary risk	Labels	State variations	Special provisions	UN packing group	Excepted quantity	Passenger and cargo aircraft		Cargo aircraft only	
									Packing instruction	Max. net quantity per package	Packing instruction	Max. net quantity per package
1	2	3	4	5	6	7	8	9	10	11	12	13
Disinfectant, solid, toxic, n.o.s.*	1601	6.1		Toxic		A3 A5	I II	E5 E4	666	5 kg	673	50 kg
									669	25 kg	676	100 kg
									Y644	1 kg		
									670 Y645	100 kg 10 kg	677	200 kg
Disodium trioxosilicate	3253	8		Corrosive			III	E1	860 Y845	25 kg 5 kg	864	100 kg
Disuccinic acid peroxide 72% or more	FORBIDDEN											
Divinyl ether, stabilized	1167	3		Liquid flammable			I	E3	351	1 L	361	30 L
Dodecyltrichlorosilane	1771	8		Corrosive	AU 1 CA 7 IR 3 NL 1 US 3	A1	II	E0	FORBIDDEN		876	30 L
Drugs, n.o.s., see Consumer commodity												
Drugs, corrosive, liquid, n.o.s., see Corrosive liquid, n.o.s.												
Drugs, corrosive, solid, n.o.s., see Corrosive solid, n.o.s.												
Drugs, flammable, liquid, n.o.s., see Flammable liquid, n.o.s.												
Drugs, flammable, solid, n.o.s., see Flammable solid, inorganic, n.o.s. or organic, n.o.s.												
Drugs, oxidizing substance, n.o.s., see Oxidizing liquid or solid, n.o.s.												
Drugs, toxic, liquid, n.o.s., see Toxic liquid, organic, n.o.s.												
Drugs, toxic, solid, n.o.s., see Toxic solid, organic, n.o.s.												
Dry ice	1845	9		Miscellaneous		A48 A151		E0	954	200 kg	954	200 kg
Dye and dye intermediate, n.o.s., flammable liquid, see Flammable liquid, n.o.s.												

Name	UN No.	Class or division	Subsidiary risk	Labels	State variations	Special provisions	UN packing group	Excepted quantity	Passenger and cargo aircraft		Cargo aircraft only				
									Packing instruction	Max. net quantity per package	Packing instruction	Max. net quantity per package			
1	2	3	4	5	6	7	8	9	10	11	12	13			
Dye intermediate, liquid, corrosive, n.o.s.* †	2801	8		Corrosive		A3	I	E0	850	0.5 L	854	2.5 L			
									851	1 L	855	30 L			
									Y840	0.5 L					
									852	5 L	856	60 L			
							III	E1	Y841	1 L					
Dye intermediate, liquid, toxic, n.o.s.* †	1602	6.1		Toxic		A3	I	E5	652	1 L	658	30 L			
									A4	II	E4	654	5 L	662	60 L
										III	E1	Y641	1 L		
												655	60 L	663	220 L
									Y642	2 L					
Dye intermediate, solid, corrosive, n.o.s.* †	3147	8		Corrosive		A3	I	E0	858	1 kg	862	25 kg			
										II	E2	859	15 kg	863	50 kg
										III	E1	Y844	5 kg		
												860	25 kg	864	100 kg
									Y845	5 kg					
Dye intermediate, solid, toxic, n.o.s.* †	3143	6.1		Toxic		A3	I	E5	666	5 kg	673	50 kg			
									A5	II	E4	669	25 kg	676	100 kg
										III	E1	Y644	1 kg		
												670	100 kg	677	200 kg
									Y645	10 kg					
Dye, liquid, corrosive, n.o.s.*	2801	8		Corrosive		A3	I	E0	850	0.5 L	854	2.5 L			
										II	E2	851	1 L	855	30 L
										III	E1	Y840	0.5 L		
												852	5 L	856	60 L
									Y841	1 L					
Dye, liquid, toxic, n.o.s.*	1602	6.1		Toxic		A3	I	E5	652	1 L	658	30 L			
									A4	II	E4	654	5 L	662	60 L
										III	E1	Y641	1 L		
												655	60 L	663	220 L
									Y642	2 L					
Dye, solid, corrosive, n.o.s.*	3147	8		Corrosive		A3	I	E0	858	1 kg	862	25 kg			
										II	E2	859	15 kg	863	50 kg
										III	E1	Y844	5 kg		
												860	25 kg	864	100 kg
									Y845	5 kg					
Dye, solid, toxic, n.o.s.*	3143	6.1		Toxic		A3	I	E5	666	5 kg	673	50 kg			
									A5	II	E4	669	25 kg	676	100 kg
										III	E1	Y644	1 kg		
												670	100 kg	677	200 kg
									Y645	10 kg					
Dynamite, see Explosive, blasting, type A															

Name	UN No.	Class or division	Subsidiary risk	Labels	State variations	Special provisions	UN packing group	Excepted quantity	Passenger and cargo aircraft		Cargo aircraft only	
									Packing instruction	Max. net quantity per package	Packing instruction	Max. net quantity per package
1	2	3	4	5	6	7	8	9	10	11	12	13
E												
Electric storage batteries, see Batteries , etc. (UN Nos. 2794, 2795, 2800, 3028)												
Electrolyte (acid or alkaline) for batteries †, see Battery fluid, acid or Battery fluid, alkali												
Electron tubes containing mercury, see Mercury contained in manufactured articles												
Elevated temperature liquid, n.o.s.* , at or above 100°C and below its flash point (including molten metals, molten salts, etc.)	3257	9							FORBIDDEN		FORBIDDEN	
Elevated temperature liquid, flammable, n.o.s.* , with flash point above 60°C, at or above its flash point	3256	3							FORBIDDEN		FORBIDDEN	
Elevated temperature solid, n.o.s.* , at or above 240°C	3258	9							FORBIDDEN		FORBIDDEN	
Engine, fuel cell, flammable gas powered †	3166	9		Miscellaneous		A67 A70 A87 A134 A176		E0	FORBIDDEN		951	No limit
Engine, fuel cell, flammable liquid powered †	3166	9		Miscellaneous		A67 A70 A87 A134 A176		E0	950	No limit	950	No limit
Engine, internal combustion, flammable gas powered	3166	9		Miscellaneous		A67 A70 A87 A134		E0	FORBIDDEN		951	No limit
Engine, internal combustion, flammable liquid powered	3166	9		Miscellaneous		A67 A70 A87 A134		E0	950	No limit	950	No limit
Engines, rocket, see Rocket motors , etc.												

Name	UN No.	Class or division	Subsidiary risk	Labels	State variations	Special provisions	UN packing group	Excepted quantity	Passenger and cargo aircraft		Cargo aircraft only	
									Packing instruction	Max. net quantity per package	Packing instruction	Max. net quantity per package
1	2	3	4	5	6	7	8	9	10	11	12	13
≠ Environmentally hazardous substance, liquid, n.o.s.*	3082	9		Miscellaneous	DE 5 US 4	A97 A158 A197	III	E1	964 Y964	450 L 30 kg G	964	450 L
≠ Environmentally hazardous substance, solid, n.o.s.*	3077	9		Miscellaneous	DE 5 US 4	A97 A158 A179 A197	III	E1	956 Y956	400 kg 30 kg G	956	400 kg
Epibromohydrin	2558	6.1	3						FORBIDDEN		FORBIDDEN	
Epichlorohydrin	2023	6.1	3	Toxic & Liquid flammable	US 4	A113	II	E4	654 Y641	5 L 1 L	662	60 L
1,2-Epoxybutane, stabilized, see 1,2-Butylene oxide, stabilized												
Epoxyethane, see Ethylene oxide												
1,2-Epoxy-3-ethoxypropane	2752	3		Liquid flammable			III	E1	355 Y344	60 L 10 L	366	220 L
2,3-Epoxy-1-propanal, see Glycidaldehyde												
2,3-Epoxypropyl ethyl ether, see 1,2-Epoxy-3-ethoxypropane												
Esters, n.o.s.*	3272	3		Liquid flammable		A3	II III	E2 E1	353 Y341 355 Y344	5 L 1 L 60 L 10 L	364 366	60 L 220 L
Ethane	1035	2.1		Gas flammable	AU 1 CA 7 IR 3 NL 1 US 3	A1		E0	FORBIDDEN		200	150 kg
Ethane, refrigerated liquid	1961	2.1							FORBIDDEN		FORBIDDEN	
Ethanethiol, see Ethyl mercaptan												
Ethanol	1170	3		Liquid flammable		A3 A58 A180	II III	E2 E1	353 Y341 355 Y344	5 L 1 L 60 L 10 L	364 366	60 L 220 L
Ethanolamine	2491	8		Corrosive		A3	III	E1	852 Y841	5 L 1 L	856	60 L
Ethanol amine dinitrate	FORBIDDEN											

Name	UN No.	Class or division	Subsidiary risk	Labels	State variations	Special provisions	UN packing group	Excepted quantity	Passenger and cargo aircraft		Cargo aircraft only	
									Packing instruction	Max. net quantity per package	Packing instruction	Max. net quantity per package
1	2	3	4	5	6	7	8	9	10	11	12	13
Ethanolamine solution	2491	8		Corrosive		A3	III	E1	852 Y841	5 L 1 L	856	60 L
Ethanol and gasoline mixture, with more than 10% ethanol	3475	3		Liquid flammable		A156	II	E2	353 Y341	5 L 1 L	364	60 L
Ethanol and motor spirit mixture, with more than 10% ethanol	3475	3		Liquid flammable		A156	II	E2	353 Y341	5 L 1 L	364	60 L
Ethanol and petrol mixture, with more than 10% ethanol	3475	3		Liquid flammable		A156	II	E2	353 Y341	5 L 1 L	364	60 L
Ethanol solution	1170	3		Liquid flammable		A3 A58 A180	II III	E2 E1	353 Y341 355 Y344	5 L 1 L 60 L 10 L	364 366	60 L 220 L
Ether, see Diethyl ether												
Ethers, n.o.s.*	3271	3		Liquid flammable		A3	II III	E2 E1	353 Y341 355 Y344	5 L 1 L 60 L 10 L	364 366	60 L 220 L
2-Ethoxyethanol, see Ethylene glycol monoethyl ether												
2-Ethoxyethyl acetate, see Ethylene glycol monoethyl ether acetate												
Ethoxy propane-1, see Ethyl propyl ether												
Ethyl acetate	1173	3		Liquid flammable			II	E2	353 Y341	5 L 1 L	364	60 L
Ethylacetylene, stabilized	2452	2.1		Gas flammable	AU 1 CA 7 IR 3 NL 1 US 3	A1		E0	FORBIDDEN		200	150 kg
Ethyl acrylate, stabilized	1917	3		Liquid flammable			II	E2	353 Y341	5 L 1 L	364	60 L
Ethyl alcohol	1170	3		Liquid flammable		A3 A58 A180	II III	E2 E1	353 Y341 355 Y344	5 L 1 L 60 L 10 L	364 366	60 L 220 L
Ethyl alcohol solution	1170	3		Liquid flammable		A3 A58 A180	II III	E2 E1	353 Y341 355 Y344	5 L 1 L 60 L 10 L	364 366	60 L 220 L

Name	UN No.	Class or division	Subsidiary risk	Labels	State variations	Special provisions	UN packing group	Excepted quantity	Passenger and cargo aircraft		Cargo aircraft only	
									Packing instruction	Max. net quantity per package	Packing instruction	Max. net quantity per package
1	2	3	4	5	6	7	8	9	10	11	12	13
Ethylamine	1036	2.1		Gas flammable	AU 1 CA 7 IR 3 NL 1 US 3	A1		E0	FORBIDDEN		200	150 kg
Ethylamine, aqueous solution with not less than 50% but not more than 70% ethylamine	2270	3	8	Liquid flammable & Corrosive			II	E2	352 Y340	1 L 0.5 L	363	5 L
Ethyl amyl ketone	2271	3		Liquid flammable			III	E1	355 Y344	60 L 10 L	366	220 L
N-Ethylaniline	2272	6.1		Toxic			III	E1	655 Y642	60 L 2 L	663	220 L
2-Ethylaniline	2273	6.1		Toxic			III	E1	655 Y642	60 L 2 L	663	220 L
Ethylbenzene	1175	3		Liquid flammable			II	E2	353 Y341	5 L 1 L	364	60 L
N-Ethyl-N-benzylaniline	2274	6.1		Toxic			III	E1	655 Y642	60 L 2 L	663	220 L
N-Ethylbenzyltoluidines, liquid	2753	6.1		Toxic			III	E1	655 Y642	60 L 2 L	663	220 L
N-Ethylbenzyltoluidines, solid	3460	6.1		Toxic			III	E1	670 Y645	100 kg 10 kg	677	200 kg
Ethyl borate	1176	3		Liquid flammable			II	E2	353 Y341	5 L 1 L	364	60 L
Ethyl bromide	1891	6.1		Toxic			II	E4	654 Y641	5 L 1 L	662	60 L
Ethyl bromoacetate	1603	6.1	3		AU 1 CA 7 IR 3 NL 1 US 3	A2			FORBIDDEN		FORBIDDEN	FORBIDDEN
2-Ethylbutanol	2275	3		Liquid flammable			III	E1	355 Y344	60 L 10 L	366	220 L
2-Ethylbutyl acetate	1177	3		Liquid flammable			III	E1	355 Y344	60 L 10 L	366	220 L
Ethyl butyl ether	1179	3		Liquid flammable			II	E2	353 Y341	5 L 1 L	364	60 L
2-Ethylbutyraldehyde	1178	3		Liquid flammable			II	E2	353 Y341	5 L 1 L	364	60 L
Ethyl butyrate	1180	3		Liquid flammable			III	E1	355 Y344	60 L 10 L	366	220 L

Name	UN No.	Class or division	Subsidiary risk	Labels	State variations	Special provisions	UN packing group	Excepted quantity	Passenger and cargo aircraft		Cargo aircraft only	
									Packing instruction	Max. net quantity per package	Packing instruction	Max. net quantity per package
1	2	3	4	5	6	7	8	9	10	11	12	13
Ethyl chloride	1037	2.1		Gas flammable	AU 1 CA 7 IR 3 NL 1 US 3 US 4	A1		E0	FORBIDDEN		200	150 kg
Ethyl chloroacetate	1181	6.1	3	Toxic & Liquid flammable			II	E4	654 Y641	5 L 1 L	662	60 L
Ethyl chlorocarbonate, see Ethyl chloroformate												
Ethyl chloroformate	1182	6.1	3 8						FORBIDDEN		FORBIDDEN	
Ethyl 2-chloropropionate	2935	3		Liquid flammable			III	E1	355 Y344	60 L 10 L	366	220 L
Ethyl-alpha-chloropropionate, see Ethyl-2-chloropropionate												
Ethyl chlorothioformate	2826	8	3						FORBIDDEN		FORBIDDEN	
Ethyl crotonate	1862	3		Liquid flammable			II	E2	353 Y341	5 L 1 L	364	60 L
Ethyl dichloroarsine	1892	6.1							FORBIDDEN		FORBIDDEN	
Ethyl dichlorosilane	1183	4.3	3 8	Danger if wet & Liquid flammable & Corrosive			I	E0	FORBIDDEN		480	1 L
Ethylene	1962	2.1		Gas flammable	AU 1 CA 7 IR 3 NL 1 US 3	A1		E0	FORBIDDEN		200	150 kg
Ethylene, acetylene and propylene mixture, refrigerated liquid containing at least 71.5% ethylene with not more than 22.5% acetylene and not more than 6% propylene	3138	2.1							FORBIDDEN		FORBIDDEN	
Ethylene chlorohydrin	1135	6.1	3						FORBIDDEN		FORBIDDEN	
Ethylenediamine	1604	8	3	Corrosive & Liquid flammable			II	E2	851 Y840	1 L 0.5 L	855	30 L
Ethylene diamine diperchlorate	FORBIDDEN											
Ethylene dibromide	1605	6.1			US 4				FORBIDDEN		FORBIDDEN	

Name	UN No.	Class or division	Subsidiary risk	Labels	State variations	Special provisions	UN packing group	Excepted quantity	Passenger and cargo aircraft		Cargo aircraft only	
									Packing instruction	Max. net quantity per package	Packing instruction	Max. net quantity per package
1	2	3	4	5	6	7	8	9	10	11	12	13
Ethylene dibromide and methyl bromide, liquid mixture, see Methyl bromide and ethylene dibromide mixture, liquid												
Ethylene dichloride	1184	3	6.1	Liquid flammable & Toxic	US 4		II	E2	352 Y341	1 L 1 L	364	60 L
Ethylene glycol diethyl ether	1153	3		Liquid flammable			II III	E2 E1	353 Y341 355 Y344	5 L 1 L 60 L 10 L	364 366	60 L 220 L
Ethylene glycol dinitrate	FORBIDDEN											
Ethylene glycol monoethyl ether	1171	3		Liquid flammable			III	E1	355 Y344	60 L 10 L	366	220 L
Ethylene glycol monoethyl ether acetate	1172	3		Liquid flammable			III	E1	355 Y344	60 L 10 L	366	220 L
Ethylene glycol monomethyl ether	1188	3		Liquid flammable			III	E1	355 Y344	60 L 10 L	366	220 L
Ethylene glycol monomethyl ether acetate	1189	3		Liquid flammable			III	E1	355 Y344	60 L 10 L	366	220 L
Ethyleneimine, stabilized	1185	6.1	3						FORBIDDEN		FORBIDDEN	
Ethylene oxide	1040	2.3	2.1		AU 1 CA 7 IR 3 NL 1 US 3 US 4	A2 A131			FORBIDDEN		FORBIDDEN	
Ethylene oxide and carbon dioxide mixture with more than 9% but not more than 87% ethylene oxide	1041	2.1		Gas flammable	AU 1 CA 7 IR 3 NL 1 US 3	A1		E0	FORBIDDEN		200	25 kg
Ethylene oxide and carbon dioxide mixture , with more than 87% ethylene oxide	3300	2.3	2.1		AU 1 CA 7 IR 3 NL 1 US 3 US 4	A2			FORBIDDEN		FORBIDDEN	
Ethylene oxide and carbon dioxide mixture , with not more than 9% ethylene oxide	1952	2.2		Gas non-flammable				E1	200	75 kg	200	150 kg

Name	UN No.	Class or division	Subsidiary risk	Labels	State variations	Special provisions	UN packing group	Excepted quantity	Passenger and cargo aircraft		Cargo aircraft only	
									Packing instruction	Max. net quantity per package	Packing instruction	Max. net quantity per package
1	2	3	4	5	6	7	8	9	10	11	12	13
Ethylene oxide and chlorotetrafluoroethane mixture , with not more than 8.8% ethylene oxide	3297	2.2		Gas non-flammable				E1	200	75 kg	200	150 kg
Ethylene oxide and dichlorodifluoromethane mixture , with not more than 12.5% ethylene oxide	3070	2.2		Gas non-flammable				E1	200	75 kg	200	150 kg
Ethylene oxide and pentafluoroethane mixture , with not more than 7.9% ethylene oxide	3298	2.2		Gas non-flammable				E1	200	75 kg	200	150 kg
Ethylene oxide and propylene oxide mixture , not more than 30% ethylene oxide	2983	3	6.1	Liquid flammable & Toxic			I	E0	FORBIDDEN		361	30 L
Ethylene oxide and tetrafluoroethane mixture , with not more than 5.6% ethylene oxide	3299	2.2		Gas non-flammable				E1	200	75 kg	200	150 kg
Ethylene oxide with nitrogen up to a total pressure of 1 MPa at 50°C	1040	2.3	2.1		AU 1 CA 7 IR 3 NL 1 US 3 US 4	A2			FORBIDDEN		FORBIDDEN	
Ethylene, refrigerated liquid	1038	2.1							FORBIDDEN		FORBIDDEN	
Ethyl ether	1155	3		Liquid flammable			I	E3	351	1 L	361	30 L
Ethyl fluoride	2453	2.1		Gas flammable	AU 1 CA 7 IR 3 NL 1 US 3	A1		E0	FORBIDDEN		200	150 kg
Ethyl formate	1190	3		Liquid flammable			II	E2	353 Y341	5 L 1 L	364	60 L
2-Ethylhexylamine	2276	3	8	Liquid flammable & Corrosive			III	E1	354 Y342	5 L 1 L	365	60 L
2-Ethylhexyl chloroformate	2748	6.1	8	Toxic & Corrosive			II	E4	653 Y640	1 L 0.5 L	660	30 L
Ethyl hydroperoxide	FORBIDDEN											
Ethylidene chloride, see 1,1-Dichloroethane												
Ethyl isobutyrate	2385	3		Liquid flammable			II	E2	353 Y341	5 L 1 L	364	60 L
Ethyl isocyanate	2481	6.1	3		US 2				FORBIDDEN		FORBIDDEN	

Name	UN No.	Class or division	Subsidiary risk	Labels	State variations	Special provisions	UN packing group	Excepted quantity	Passenger and cargo aircraft		Cargo aircraft only	
									Packing instruction	Max. net quantity per package	Packing instruction	Max. net quantity per package
1	2	3	4	5	6	7	8	9	10	11	12	13
Ethyl lactate	1192	3		Liquid flammable			III	E1	355 Y344	60 L 10 L	366	220 L
Ethyl mercaptan	2363	3		Liquid flammable	AU 1 CA 7 IR 3 NL 1 US 3	A1	I	E0	FORBIDDEN		361	30 L
Ethyl methacrylate, stabilized	2277	3		Liquid flammable			II	E2	353 Y341	5 L 1 L	364	60 L
Ethyl methyl ether	1039	2.1		Gas flammable	AU 1 CA 7 IR 3 NL 1 US 3	A1		E0	FORBIDDEN		200	150 kg
Ethyl methyl ketone	1193	3		Liquid flammable			II	E2	353 Y341	5 L 1 L	364	60 L
Ethyl nitrate	FORBIDDEN											
Ethyl nitrite	FORBIDDEN											
Ethyl nitrite solution	1194	3	6.1		AU 1 CA 7 IR 3 NL 1 US 3	A2			FORBIDDEN		FORBIDDEN	
Ethyl orthoformate	2524	3		Liquid flammable			III	E1	355 Y344	60 L 10 L	366	220 L
Ethyl oxalate	2525	6.1		Toxic			III	E1	655 Y642	60 L 2 L	663	220 L
Ethyl perchlorate	FORBIDDEN											
Ethylphenyldichlorosilane	2435	8		Corrosive	AU 1 CA 7 IR 3 NL 1 US 3	A1	II	E0	FORBIDDEN		876	30 L
1-Ethylpiperidine	2386	3	8	Liquid flammable & Corrosive			II	E2	352 Y340	1 L 0.5 L	363	5 L
Ethyl propionate	1195	3		Liquid flammable			II	E2	353 Y341	5 L 1 L	364	60 L
Ethyl propyl ether	2615	3		Liquid flammable			II	E2	353 Y341	5 L 1 L	364	60 L
Ethyl silicate, see Tetraethyl silicate												

Name	UN No.	Class or division	Subsidiary risk	Labels	State variations	Special provisions	UN packing group	Excepted quantity	Passenger and cargo aircraft		Cargo aircraft only	
									Packing instruction	Max. net quantity per package	Packing instruction	Max. net quantity per package
1	2	3	4	5	6	7	8	9	10	11	12	13
Ethyl sulphate, see Diethyl sulphate												
N-Ethyltoluidines	2754	6.1		Toxic			II	E4	654 Y641	5 L 1 L	662	60 L
Ethyltrichlorosilane	1196	3	8	Liquid flammable & Corrosive			II	E0	FORBIDDEN		377	5 L
Etiologic agent, see Infectious substance , etc.												
Explosive articles, see Articles, explosive , etc.												
Explosive, blasting, type A †	0081	1.1D							FORBIDDEN		FORBIDDEN	
Explosive, blasting, type B †	0082	1.1D							FORBIDDEN		FORBIDDEN	
Explosive, blasting, type B †	0331	1.5D							FORBIDDEN		FORBIDDEN	
Explosive, blasting, type C †	0083	1.1D							FORBIDDEN		FORBIDDEN	
Explosive, blasting, type D †	0084	1.1D							FORBIDDEN		FORBIDDEN	
Explosive, blasting, type E †	0241	1.1D							FORBIDDEN		FORBIDDEN	
Explosive, blasting, type E †	0332	1.5D							FORBIDDEN		FORBIDDEN	
Explosive, emulsion, see Explosive, blasting, type E												
Explosive, seismic, see Explosive, blasting, type A, B and C												
Explosive, slurry, see Explosive blasting, type E												
Explosive substances, see Substances, explosive												
Explosive, water gel, see Explosive, blasting, type E												
Extracts, aromatic, liquid †	1169	3		Liquid flammable		A3	II	E2	353 Y341	5 L 1 L	364	60 L
							III	E1	355 Y344	60 L 10 L	366	220 L
Extracts, flavouring, liquid †	1197	3		Liquid flammable		A3	II	E2	353 Y341	5 L 1 L	364	60 L
							III	E1	355 Y344	60 L 10 L	366	220 L

Name	UN No.	Class or division	Subsidiary risk	Labels	State variations	Special provisions	UN packing group	Excepted quantity	Passenger and cargo aircraft		Cargo aircraft only	
									Packing instruction	Max. net quantity per package	Packing instruction	Max. net quantity per package
1	2	3	4	5	6	7	8	9	10	11	12	13
F												
Fabrics, animal, n.o.s., with oil	1373	4.2			AU 1 CA 7 IR 3 NL 1 US 3	A2			FORBIDDEN		FORBIDDEN	
Fabrics impregnated with weakly nitrated nitrocellulose, n.o.s.	1353	4.1		Solid flammable			III	E1	446 Y443	25 kg 10 kg	449	100 kg
Fabrics, synthetic, n.o.s., with oil	1373	4.2			AU 1 CA 7 IR 3 NL 1 US 3	A2			FORBIDDEN		FORBIDDEN	
Fabrics, vegetable, n.o.s., with oil	1373	4.2			AU 1 CA 7 IR 3 NL 1 US 3	A2			FORBIDDEN		FORBIDDEN	
Ferric arsenate	1606	6.1		Toxic			II	E4	669 Y644	25 kg 1 kg	676	100 kg
Ferric arsenite	1607	6.1		Toxic			II	E4	669 Y644	25 kg 1 kg	676	100 kg
Ferric chloride, anhydrous	1773	8		Corrosive			III	E1	860 Y845	25 kg 5 kg	864	100 kg
Ferric chloride solution	2582	8		Corrosive		A3	III	E1	852 Y841	5 L 1 L	856	60 L
Ferric nitrate	1466	5.1		Oxidizer			III	E1	559 Y546	25 kg 10 kg	563	100 kg
Ferrocerium	1323	4.1		Solid flammable		A42	II	E2	445 Y441	15 kg 5 kg	448	50 kg
Ferrosilicon with 30% or more but less than 90% silicon	1408	4.3	6.1	Danger if wet & Toxic		A3 A10	III	E1	485 Y477	25 kg 10 kg	491	100 kg
Ferrous arsenate	1608	6.1		Toxic			II	E4	669 Y644	25 kg 1 kg	676	100 kg
Ferrous metal borings in a form liable to self-heating	2793	4.2		Spontaneous combustion		A3	III	E1	469	25 kg	471	100 kg
Ferrous metal cuttings in a form liable to self-heating	2793	4.2		Spontaneous combustion		A3	III	E1	469	25 kg	471	100 kg
Ferrous metal shavings in a form liable to self-heating	2793	4.2		Spontaneous combustion		A3	III	E1	469	25 kg	471	100 kg
Ferrous metal turnings in a form liable to self-heating	2793	4.2		Spontaneous combustion		A3	III	E1	469	25 kg	471	100 kg

Name	UN No.	Class or division	Subsidiary risk	Labels	State variations	Special provisions	UN packing group	Excepted quantity	Passenger and cargo aircraft		Cargo aircraft only	
									Packing instruction	Max. net quantity per package	Packing instruction	Max. net quantity per package
1	2	3	4	5	6	7	8	9	10	11	12	13
Fertilizer ammoniating solution with free ammonia	1043	2.2		Gas non-flammable	AU 1 CA 7 IR 3 NL 1 US 3	A1		E0	FORBIDDEN		200	150 kg
Fertilizer with ammonium nitrate, n.o.s., see Ammonium nitrate based fertilizer (UN No. 2067) or Ammonium nitrate based fertilizer (UN No. 2071)												
Fibreglass repair kit, see Polyester resin kit												
+ Fibres, animal burnt, wet or damp	1372	4.2				A2			FORBIDDEN		FORBIDDEN	
Fibres, animal, n.o.s. , with oil	1373	4.2			AU 1 CA 7 IR 3 NL 1 US 3	A2			FORBIDDEN		FORBIDDEN	
Fibres impregnated with weakly nitrated nitrocellulose, n.o.s.	1353	4.1		Solid flammable	BE 3		III	E1	446 Y443	25 kg 10 kg	449	100 kg
Fibres, synthetic, n.o.s. , with oil	1373	4.2			AU 1 CA 7 IR 3 NL 1 US 3	A2			FORBIDDEN		FORBIDDEN	
+ Fibres, vegetable burnt, wet or damp	1372	4.2				A2			FORBIDDEN		FORBIDDEN	
Fibres, vegetable, n.o.s. , with oil	1373	4.2			AU 1 CA 7 IR 3 NL 1 US 3	A2			FORBIDDEN		FORBIDDEN	
+ Fibres, vegetable, dry	3360	4.1				A2			FORBIDDEN		FORBIDDEN	
Films, nitrocellulose base , gelatin coated, except scrap †	1324	4.1		Solid flammable			III	E1	454 Y454	25 kg 10 kg	454	100 kg
Films, nitrocellulose base, from which gelatin has been removed; film scrap, see Celluloid scrap												
Fire extinguisher charges , corrosive liquid †	1774	8		Corrosive			II	E0	851 Y840	1 L 0.5 L	855	30 L

Name	UN No.	Class or division	Subsidiary risk	Labels	State variations	Special provisions	UN packing group	Excepted quantity	Passenger and cargo aircraft		Cargo aircraft only	
									Packing instruction	Max. net quantity per package	Packing instruction	Max. net quantity per package
1	2	3	4	5	6	7	8	9	10	11	12	13
Fire extinguisher charges, expelling, explosive, see Cartridges, power device												
Fire extinguishers with compressed or liquefied gas	1044	2.2		Gas non-flammable		A19		E0	213	75 kg	213	150 kg
Firelighters, solid with flammable liquid †	2623	4.1		Solid flammable			III	E1	446 Y443	25 kg 10 kg	449	100 kg
Fireworks †	0333	1.1G							FORBIDDEN		FORBIDDEN	
Fireworks †	0334	1.2G							FORBIDDEN		FORBIDDEN	
Fireworks †	0335	1.3G							FORBIDDEN		FORBIDDEN	
Fireworks †	0336	1.4G		Explosive 1.4				E0	FORBIDDEN		135	75 kg
Fireworks †	0337	1.4S		Explosive 1.4				E0	135	25 kg	135	100 kg
≠ First aid kit	3316	9		Miscellaneous		A44 A163	II	E0	960 Y960	10 kg 1 kg	960	10 kg
							III	E0	960 Y960	10 kg 1 kg	960	10 kg
+ Fish meal, stabilized	2216	9				A2			FORBIDDEN		FORBIDDEN	
+ Fish meal, unstabilized	1374	4.2				A2			FORBIDDEN		FORBIDDEN	
+ Fish scrap, stabilized	2216	9				A2			FORBIDDEN		FORBIDDEN	
+ Fish scrap, unstabilized	1374	4.2				A2			FORBIDDEN		FORBIDDEN	
Flammable gas, see Compressed or Liquefied gas, flammable , etc.												
Flammable gas in lighters, see Lighters (cigarettes), containing flammable gas												
Flammable gas (small receptacles not fitted with a dispersion device, not refillable), see Receptacles , etc.												
Flammable liquid, n.o.s.*	1993	3		Liquid flammable		A3	I	E3	351	1 L	361	30 L
							II	E2	353	5 L	364	60 L
							III	E1	Y341 355 Y344	1 L 60 L 10 L	366	220 L
Flammable liquid, corrosive, n.o.s.*	2924	3	8	Liquid flammable & Corrosive		A3	I	E0	350	0.5 L	360	2.5 L
							II	E2	352	1 L	363	5 L
							III	E1	Y340 354 Y342	0.5 L 5 L 1 L	365	60 L

Name	UN No.	Class or division	Subsidiary risk	Labels	State variations	Special provisions	UN packing group	Excepted quantity	Passenger and cargo aircraft		Cargo aircraft only	
									Packing instruction	Max. net quantity per package	Packing instruction	Max. net quantity per package
1	2	3	4	5	6	7	8	9	10	11	12	13
Flammable liquid, toxic, n.o.s.*	1992	3	6.1	Liquid flammable & Toxic		A3	I	E0	FORBIDDEN		361	30 L
									352	1 L	364	60 L
									Y341	1 L		
									355	60 L	366	220 L
							III	E1	Y343	2 L		
Flammable liquid, toxic, corrosive, n.o.s.*	3286	3	6.1 8	Liquid flammable & Toxic & Corrosive			I	E0	FORBIDDEN		360	2.5 L
									352	1 L	363	5 L
							II	E2	Y340	0.5 L		
Flammable solid, corrosive, inorganic, n.o.s.*	3180	4.1	8	Solid flammable & Corrosive		A3	II	E2	445	15 kg	448	50 kg
									Y441	5 kg		
									446	25 kg	449	100 kg
							III	E1	Y442	5 kg		
Flammable solid, corrosive, organic, n.o.s.*	2925	4.1	8	Solid flammable & Corrosive		A3	II	E2	445	15 kg	448	50 kg
									Y441	5 kg		
									446	25 kg	449	100 kg
							III	E1	Y442	5 kg		
Flammable solid, inorganic, n.o.s.*	3178	4.1		Solid flammable		A3	II	E2	445	15 kg	448	50 kg
									Y441	5 kg		
									446	25 kg	449	100 kg
							III	E1	Y443	10 kg		
Flammable solid, organic, n.o.s.*	1325	4.1		Solid flammable		A3	II	E2	445	15 kg	448	50 kg
									Y441	5 kg		
									446	25 kg	449	100 kg
							III	E1	Y443	10 kg		
Flammable solid, organic, molten, n.o.s.*	3176	4.1				A3			FORBIDDEN		FORBIDDEN	FORBIDDEN
Flammable solid, oxidizing, n.o.s.*	3097	4.1	5.1			A3			FORBIDDEN		FORBIDDEN	FORBIDDEN
Flammable solid, toxic, inorganic, n.o.s.*	3179	4.1	6.1	Solid flammable & Toxic		A3	II	E2	445	15 kg	448	50 kg
									Y440	1 kg		
									446	25 kg	449	100 kg
							III	E1	Y443	10 kg		
Flammable solid, toxic, organic, n.o.s.*	2926	4.1	6.1	Solid flammable & Toxic		A3	II	E2	445	15 kg	448	50 kg
									Y440	1 kg		
									446	25 kg	449	100 kg
							III	E1	Y443	10 kg		
Flares, aerial †	0093	1.3G		Explosive				E0	FORBIDDEN		135	75 kg
Flares, aerial †	0403	1.4G		Explosive 1.4				E0	FORBIDDEN		135	75 kg
Flares, aerial †	0404	1.4S		Explosive 1.4				E0	135	25 kg	135	100 kg
Flares, aerial †	0420	1.1G							FORBIDDEN		FORBIDDEN	FORBIDDEN
Flares, aerial †	0421	1.2G							FORBIDDEN		FORBIDDEN	FORBIDDEN

Name	UN No.	Class or division	Subsidiary risk	Labels	State variations	Special provisions	UN packing group	Excepted quantity	Passenger and cargo aircraft		Cargo aircraft only	
									Packing instruction	Max. net quantity per package	Packing instruction	Max. net quantity per package
1	2	3	4	5	6	7	8	9	10	11	12	13
Flares, aeroplane, see Flares, aerial												
Flares, distress, small, see Signal devices, hand												
Flares, railway or highway, see Signal devices, hand												
Flares, surface †	0092	1.3G		Explosive				E0	FORBIDDEN		135	75 kg
Flares, surface †	0418	1.1G							FORBIDDEN		FORBIDDEN	
Flares, surface †	0419	1.2G							FORBIDDEN		FORBIDDEN	
Flares, water-activated, see Contrivances, water-activated, etc.												
Flash powder †	0094	1.1G							FORBIDDEN		FORBIDDEN	
Flash powder †	0305	1.3G							FORBIDDEN		FORBIDDEN	
Flue dusts, toxic, see Arsenical dust												
Fluoric acid, see Hydrofluoric acid (UN No. 1790)												
Fluorine, compressed	1045	2.3	5.1 8		AU 1 CA 7 IR 3 NL 1 US 3	A2			FORBIDDEN		FORBIDDEN	
Fluoroacetic acid	2642	6.1		Toxic			I	E5	665	1 kg	672	15 kg
2-Fluoroaniline, see Fluoroanilines												
4-Fluoroaniline, see Fluoroanilines												
o-Fluoroaniline, see Fluoroanilines												
p-Fluoroaniline, see Fluoroanilines												
Fluoroanilines	2941	6.1		Toxic			III	E1	655 Y642	60 L 2 L	663	220 L
Fluorobenzene	2387	3		Liquid flammable			II	E2	353 Y341	5 L 1 L	364	60 L
Fluoroboric acid	1775	8		Corrosive			II	E2	851 Y840	1 L 0.5 L	855	30 L

Name	UN No.	Class or division	Subsidiary risk	Labels	State variations	Special provisions	UN packing group	Excepted quantity	Passenger and cargo aircraft		Cargo aircraft only	
									Packing instruction	Max. net quantity per package	Packing instruction	Max. net quantity per package
1	2	3	4	5	6	7	8	9	10	11	12	13
Fluoroethane, see Ethyl fluoride												
Fluoroform, see Trifluoromethane												
Fluoromethane, see Methyl fluoride												
Fluorophosphoric acid, anhydrous	1776	8		Corrosive			II	E2	851 Y840	1 L 0.5 L	855	30 L
Fluorosilicates, n.o.s.*	2856	6.1		Toxic			III	E1	670 Y645	100 kg 10 kg	677	200 kg
Fluorosilicic acid	1778	8		Corrosive			II	E2	851 Y840	1 L 0.5 L	855	30 L
Fluorosulphonic acid	1777	8		Corrosive			I	E0	850	0.5 L	854	2.5 L
Fluorotoluenes	2388	3		Liquid flammable			II	E2	353 Y341	5 L 1 L	364	60 L
Formaldehyde solution with less than 25 per cent formaldehyde						A189						
Formaldehyde solution with not less than 25% formaldehyde	2209	8		Corrosive	US 4		III	E1	852 Y841	5 L 1 L	856	60 L
Formaldehyde solution, flammable	1198	3	8	Liquid flammable & Corrosive		A180	III	E1	354 Y342	5 L 1 L	365	60 L
Formalin, see Formaldehyde solution												
Formamidine sulphinic acid, see Thiourea dioxide												
Formic acid with more than 85% acid by mass	1779	8	3	Corrosive & Liquid flammable			II	E2	851 Y840	1 L 0.5 L	855	30 L
Formic acid with not less than 5% but less than 10% acid by mass	3412	8		Corrosive			III	E1	852 Y841	5 L 1 L	856	60 L
Formic acid with not less than 10% but not more than 85% acid by mass	3412	8		Corrosive			II	E2	851 Y840	1 L 0.5 L	855	30 L
Formic aldehyde, see Formaldehyde solution												
2-Formyl-3,4-dihydro-2H-pyran, see Acrolein dimer, stabilized												

Name	UN No.	Class or division	Subsidiary risk	Labels	State variations	Special provisions	UN packing group	Excepted quantity	Passenger and cargo aircraft		Cargo aircraft only	
									Packing instruction	Max. net quantity per package	Packing instruction	Max. net quantity per package
1	2	3	4	5	6	7	8	9	10	11	12	13
Fracturing devices, explosive, without detonator for oil wells †	0099	1.1D			AU 2 CA 7 IR 3 NL 1 US 3	A2			FORBIDDEN		FORBIDDEN	
Fuel, aviation, turbine engine	1863	3		Liquid flammable		A3	I II III	E3 E2 E1	351 353 Y341 355 Y344	1 L 5 L 1 L 60 L 10 L	361 364 366	30 L 60 L 220 L
Fuel cell cartridges, containing corrosive substances †	3477	8		Corrosive		A146 A157		E0	873 Y873	5 kg 2.5 kg	873	50 kg
Fuel cell cartridges, containing flammable liquids †	3473	3		Liquid flammable		A146		E0	374 Y374	5 kg 2.5 kg	374	50 kg
Fuel cell cartridges, containing hydrogen in metal hydride †	3479	2.1		Gas flammable		A146 A162		E0	215 Y215	1 kg 0.5 kg	215	15 kg
Fuel cell cartridges, containing liquefied flammable gas †	3478	2.1		Gas flammable		A146 A161		E0	215 Y215	1 kg 0.5 kg	215	15 kg
Fuel cell cartridges, containing water-reactive substances †	3476	4.3		Danger if wet		A146 A157		E0	495 Y495	5 kg 2.5 kg	495	50 kg
Fuel cell cartridges contained in equipment, containing corrosive substances	3477	8		Corrosive		A146 A157		E0	874	5 kg	874	50 kg
Fuel cell cartridges contained in equipment, containing flammable liquids	3473	3		Liquid flammable		A146		E0	375	5 kg	375	50 kg
Fuel cell cartridges contained in equipment, containing hydrogen in metal hydride	3479	2.1		Gas flammable		A146 A162		E0	216	1 kg	216	15 kg
Fuel cell cartridges contained in equipment, containing liquefied flammable gas	3478	2.1		Gas flammable		A146 A161		E0	216	1 kg	216	15 kg
Fuel cell cartridges contained in equipment, containing water-reactive substances	3476	4.3		Danger if wet		A146 A157		E0	496	5 kg	496	50 kg
Fuel cell cartridges packed with equipment, containing corrosive substances	3477	8		Corrosive		A146 A157		E0	875	5 kg	875	50 kg
Fuel cell cartridges packed with equipment, containing flammable liquids	3473	3		Liquid flammable		A146		E0	376	5 kg	376	50 kg

Chapter 2

3-2-103

Name	UN No.	Class or division	Subsidiary risk	Labels	State variations	Special provisions	UN packing group	Excepted quantity	Passenger and cargo aircraft		Cargo aircraft only	
									Packing instruction	Max. net quantity per package	Packing instruction	Max. net quantity per package
1	2	3	4	5	6	7	8	9	10	11	12	13
Fuel cell cartridges packed with equipment , containing hydrogen in metal hydride	3479	2.1		Gas flammable		A146 A162		E0	217	1 kg	217	15 kg
Fuel cell cartridges packed with equipment , containing liquefied flammable gas	3478	2.1		Gas flammable		A146 A161		E0	217	1 kg	217	15 kg
Fuel cell cartridges packed with equipment , containing water-reactive substances	3476	4.3		Danger if wet		A146 A157		E0	497	5 kg	497	50 kg
Fuel system components (including fuel control units (FCU), carburetors, fuel lines, fuel pumps), see Dangerous goods in apparatus or Dangerous Goods in machinery (UN No. 3363)												
Fulminate of mercury (dry)	FORBIDDEN											
Fulminate of mercury, wet, see Mercury fulminate , etc.												
Fulminating gold	FORBIDDEN											
Fulminating mercury	FORBIDDEN											
Fulminating platinum	FORBIDDEN											
Fulminating silver	FORBIDDEN											
Fulminic acid	FORBIDDEN											
Fumaroyl dichloride, see Fumaryl chloride												
Fumaryl chloride	1780	8		Corrosive			II	E2	851 Y840	1 L 0.5 L	855	30 L
Fumigant, see appropriate pesticide												
+ Fumigated cargo transport unit	3359	9							FORBIDDEN		FORBIDDEN	
Fungicide, see appropriate pesticide												
Furaldehydes	1199	6.1	3	Toxic & Liquid flammable			II	E4	654 Y641	5 L 1 L	662	60 L
Furan	2389	3		Liquid flammable			I	E3	351	1 L	361	30 L

Name	UN No.	Class or division	Subsidiary risk	Labels	State variations	Special provisions	UN packing group	Excepted quantity	Passenger and cargo aircraft		Cargo aircraft only	
									Packing instruction	Max. net quantity per package	Packing instruction	Max. net quantity per package
1	2	3	4	5	6	7	8	9	10	11	12	13
Furfuryl alcohol	2874	6.1		Toxic			III	E1	655 Y642	60 L 2 L	663	220 L
Furfurylamine	2526	3	8	Liquid flammable & Corrosive			III	E1	354 Y342	5 L 1 L	365	60 L
Furyl carbinol, see Furfuryl alcohol												
Fuse, detonating , metal clad	0102	1.2D							FORBIDDEN		FORBIDDEN	
Fuse, detonating , metal clad	0290	1.1D							FORBIDDEN		FORBIDDEN	
Fuse, detonating, mild effect , metal clad	0104	1.4D		Explosive 1.4				E0	FORBIDDEN		139	75 kg
Fuse, igniter , tubular, metal clad †	0103	1.4G		Explosive 1.4				E0	FORBIDDEN		140	75 kg
Fusel oil	1201	3		Liquid flammable		A3	II	E2	353 Y341	5 L 1 L	364	60 L
							III	E1	355 Y344	60 L 10 L	366	220 L
Fuse, non-detonating †	0101	1.3G							FORBIDDEN		FORBIDDEN	
Fuse, safety †	0105	1.4S		Explosive 1.4				E0	140	25 kg	140	100 kg
Fuzes, combination, percussion or time, see Fuzes, detonating (UN Nos. 0257, 0367); Fuzes, igniting (UN Nos. 0317, 0368)												
Fuzes, detonating †	0106	1.1B							FORBIDDEN		FORBIDDEN	
Fuzes, detonating †	0107	1.2B							FORBIDDEN		FORBIDDEN	
Fuzes, detonating †	0257	1.4B		Explosive 1.4				E0	FORBIDDEN		141	75 kg
Fuzes, detonating †	0367	1.4S		Explosive 1.4				E0	141	25 kg	141	100 kg
Fuzes, detonating with protective features †	0408	1.1D							FORBIDDEN		FORBIDDEN	
Fuzes, detonating with protective features †	0409	1.2D							FORBIDDEN		FORBIDDEN	
Fuzes, detonating with protective features †	0410	1.4D		Explosive 1.4				E0	FORBIDDEN		141	75 kg
Fuzes, igniting †	0316	1.3G							FORBIDDEN		FORBIDDEN	
Fuzes, igniting †	0317	1.4G		Explosive 1.4				E0	FORBIDDEN		141	75 kg
Fuzes, igniting †	0368	1.4S		Explosive 1.4				E0	141	25 kg	141	100 kg

Name	UN No.	Class or division	Subsidiary risk	Labels	State variations	Special provisions	UN packing group	Excepted quantity	Passenger and cargo aircraft		Cargo aircraft only	
									Packing instruction	Max. net quantity per package	Packing instruction	Max. net quantity per package
1	2	3	4	5	6	7	8	9	10	11	12	13
G												
Galactan trinitrate	FORBIDDEN											
Gallium †	2803	8		Corrosive		A69	III	E0	867	20 kg	867	20 kg
Gas cartridges , (flammable) without a release device, non-refillable	2037	2.1		Gas flammable		A167		E0	203 Y203	1 kg 1 kg	203	15 kg
Gas cartridges (non-flammable) without a release device, non-refillable	2037	2.2		Gas non-flammable		A98 A167		E0	203 Y203	1 kg 1 kg	203	15 kg
Gas cartridges (oxidizing) without a release device, non-refillable	2037	2.2	5.1	Gas non-flammable & Oxidizer		A167		E0	203	1 kg	203	15 kg
Gas cartridges (toxic & corrosive) without a release device, non-refillable	2037	2.3	8		AU 1 CA 7 IR 3 NL 1 US 3	A2			FORBIDDEN		FORBIDDEN	
Gas cartridges (toxic, flammable & corrosive) without a release device, non-refillable	2037	2.3	2.1 8		AU 1 CA 7 IR 3 NL 1 US 3	A2			FORBIDDEN		FORBIDDEN	
Gas cartridges (toxic & flammable) without a release device, non-refillable	2037	2.3	2.1		AU 1 CA 7 IR 3 NL 1 US 3	A2			FORBIDDEN		FORBIDDEN	
Gas cartridges (toxic, oxidizing & corrosive) without a release device, non-refillable	2037	2.3	5.1 8		AU 1 CA 7 IR 3 NL 1 US 3	A2			FORBIDDEN		FORBIDDEN	
Gas cartridges (toxic & oxidizing) without a release device, non-refillable	2037	2.3	5.1		AU 1 CA 7 IR 3 NL 1 US 3	A2			FORBIDDEN		FORBIDDEN	

Name	UN No.	Class or division	Subsidiary risk	Labels	State variations	Special provisions	UN packing group	Excepted quantity	Passenger and cargo aircraft		Cargo aircraft only	
									Packing instruction	Max. net quantity per package	Packing instruction	Max. net quantity per package
1	2	3	4	5	6	7	8	9	10	11	12	13
Gas cartridges (toxic) without a release device, non-refillable	2037	2.3			AU 1 CA 7 IR 3 NL 1 US 3	A2				FORBIDDEN		FORBIDDEN
Gas, compressed, see Compressed gas , etc.												
Gas drips, hydrocarbon †, see Hydrocarbons, liquid, n.o.s.												
Gas liquefied, see Liquefied gas , etc.												
Gas oil	1202	3		Liquid flammable		A3	III	E1	355 Y344	60 L 10 L	366	220 L
Gasoline	1203	3		Liquid flammable		A100	II	E2	353 Y341	5 L 1 L	364	60 L
Gasoline, casinghead, see Gasoline												
Gas, refrigerated liquid, n.o.s.*	3158	2.2		Gas non-flammable				E1	202	50 kg	202	500 kg
Gas, refrigerated liquid, flammable, n.o.s.*	3312	2.1							FORBIDDEN		FORBIDDEN	
Gas, refrigerated liquid, oxidizing, n.o.s.*	3311	2.2	5.1		AU 1 CA 7 IR 3 NL 1 US 3	A2			FORBIDDEN		FORBIDDEN	
Gas sample, non-pressurized, flammable, n.o.s. , not refrigerated liquid	3167	2.1		Gas flammable				E0	206	1 L	206	5 L
Gas sample, non-pressurized, toxic, n.o.s. , not refrigerated liquid	3169	2.3		Gas toxic	AU 1 CA 7 IR 3 NL 1 US 3	A1		E0	FORBIDDEN		206	1 L
Gas sample, non-pressurized, toxic, flammable, n.o.s. , not refrigerated liquid	3168	2.3	2.1	Gas toxic & Gas flammable	AU 1 CA 7 IR 3 NL 1 US 3	A1		E0	FORBIDDEN		206	1 L
Gas turbine engines †, see Engines, internal combustion (UN No. 3166)												

Name	UN No.	Class or division	Subsidiary risk	Labels	State variations	Special provisions	UN packing group	Excepted quantity	Passenger and cargo aircraft		Cargo aircraft only	
									Packing instruction	Max. net quantity per package	Packing instruction	Max. net quantity per package
1	2	3	4	5	6	7	8	9	10	11	12	13
Gelatin, blasting, see Explosive, blasting, type A												
Gelatin dynamites, see Explosive, blasting, type A												
Genetically modified micro-organisms	3245	9		None		A47		E0	959	No limit	959	No limit
Genetically modified organisms	3245	9		None		A47		E0	959	No limit	959	No limit
Germane	2192	2.3	2.1		AU 1 CA 7 IR 3 NL 1 US 3	A2			FORBIDDEN		FORBIDDEN	
+ Germane, adsorbed	3523	2.3	2.1			A2		E0	FORBIDDEN		FORBIDDEN	
Germanium hydride, see Germane												
Glycer-1,3-dichlorohydrin, see 1,3-Dichloropropanol-2												
Glycerol-1,3-dinitrate									FORBIDDEN			
Glycerol gluconate trinitrate									FORBIDDEN			
Glycerol lactate trinitrate									FORBIDDEN			
Glycerol alpha-monochlorohydrin	2689	6.1		Toxic			III	E1	655 Y642	60 L 2 L	663	220 L
Glyceryl trinitrate, see Nitroglycerin , etc.												
Glycidaldehyde	2622	3	6.1	Liquid flammable & Toxic	US 4		II	E2	352 Y341	1 L 1 L	364	60 L
Grenades , hand or rifle, with bursting charge †	0284	1.1D							FORBIDDEN		FORBIDDEN	
Grenades , hand or rifle, with bursting charge †	0285	1.2D							FORBIDDEN		FORBIDDEN	
Grenades , hand or rifle, with bursting charge †	0292	1.1F							FORBIDDEN		FORBIDDEN	
Grenades , hand or rifle, with bursting charge †	0293	1.2F							FORBIDDEN		FORBIDDEN	

Name	UN No.	Class or division	Subsidiary risk	Labels	State variations	Special provisions	UN packing group	Excepted quantity	Passenger and cargo aircraft		Cargo aircraft only	
									Packing instruction	Max. net quantity per package	Packing instruction	Max. net quantity per package
1	2	3	4	5	6	7	8	9	10	11	12	13
Grenades, illuminating †, see Ammunition, illuminating , etc. (UN Nos. 0171, 0254, 0297)												
Grenades, practice , hand or rifle †	0110	1.4S		Explosive 1.4				E0	141	25 kg	141	100 kg
Grenades, practice , hand or rifle †	0318	1.3G							FORBIDDEN		FORBIDDEN	
Grenades, practice , hand or rifle †	0372	1.2G							FORBIDDEN		FORBIDDEN	
Grenades, practice , hand or rifle †	0452	1.4G		Explosive 1.4				E0	FORBIDDEN		141	75 kg
Grenades, smoke, see Ammunition, smoke , etc. (UN Nos. 0015; 0016; 0245; 0246; 0303)												
Guanidine nitrate	1467	5.1		Oxidizer			III	E1	559 Y546	25 kg 10 kg	563	100 kg
Guanyl nitrosaminoguanylidene hydrazine (dry)	FORBIDDEN											
Guanyl nitrosaminoguanylidene hydrazine, wetted with not less than 30% water, by mass	0113	1.1A							FORBIDDEN		FORBIDDEN	
Guanyl nitrosaminoguanyltetrazene (dry)	FORBIDDEN											
Guanyl nitrosaminoguanyltetrazene, wetted with not less than 30% water, or mixture of alcohol and water, by mass	0114	1.1A							FORBIDDEN		FORBIDDEN	
Gunpowder , granular or as a meal	0027	1.1D							FORBIDDEN		FORBIDDEN	
Gunpowder, compressed	0028	1.1D							FORBIDDEN		FORBIDDEN	
Gunpowder in pellets	0028	1.1D							FORBIDDEN		FORBIDDEN	
Gutta percha solution, see Rubber solution												
H												
Hafnium powder, dry	2545	4.2		Spontaneous combustion		A3	II III	E2 E1	FORBIDDEN 467	15 kg 25 kg	FORBIDDEN 470 471	50 kg 100 kg

Name	UN No.	Class or division	Subsidiary risk	Labels	State variations	Special provisions	UN packing group	Excepted quantity	Passenger and cargo aircraft		Cargo aircraft only	
									Packing instruction	Max. net quantity per package	Packing instruction	Max. net quantity per package
1	2	3	4	5	6	7	8	9	10	11	12	13
Hafnium powder, wetted with not less than 25% water (a visible excess of water must be present) (a) mechanically produced, particle size less than 53 microns; (b) chemically produced, particle size less than 840 microns	1326	4.1		Solid flammable		A35	II	E2	445 Y441	15 kg 5 kg	448	50 kg
Hay	1327	4.1				A2 A198			FORBIDDEN		FORBIDDEN	
Heating oil, light	1202	3		Liquid flammable		A3	III	E1	355 Y344	60 L 10 L	366	220 L
Heat producing articles, battery operated equipment, such as underwater torches or soldering equipment, which, if accidentally activated, will generate extreme heat and can cause fire	—	9				A93			FORBIDDEN		FORBIDDEN	
Heavy hydrogen, see Deuterium, compressed (UN No. 1957)												
Helium, compressed	1046	2.2		Gas non-flammable		A69		E1	200	75 kg	200	150 kg
Helium, refrigerated liquid	1963	2.2		Gas non-flammable				E1	202	50 kg	202	500 kg
Heptafluoropropane	3296	2.2		Gas non-flammable				E1	200	75 kg	200	150 kg
n-Heptaldehyde	3056	3		Liquid flammable			III	E1	355 Y344	60 L 10 L	366	220 L
n-Heptanal, see n-Heptaldehyde												
Heptanes	1206	3		Liquid flammable			II	E2	353 Y341	5 L 1 L	364	60 L
4-Heptanone, see Dipropyl ketone												
n-Heptene	2278	3		Liquid flammable			II	E2	353 Y341	5 L 1 L	364	60 L
Hexachloroacetone	2661	6.1		Toxic			III	E1	655 Y642	60 L 2 L	663	220 L
Hexachlorobenzene	2729	6.1		Toxic	US 4		III	E1	670 Y645	100 kg 10 kg	677	200 kg
Hexachlorobutadiene	2279	6.1		Toxic	US 4		III	E1	655 Y642	60 L 2 L	663	220 L
Hexachloro-1,3-butadiene, see Hexachlorobutadiene												
Hexachlorocyclopentadiene	2646	6.1			US 4				FORBIDDEN		FORBIDDEN	
Hexachlorophene	2875	6.1		Toxic	US 4		III	E1	670 Y645	100 kg 10 kg	677	200 kg

Name	UN No.	Class or division	Subsidiary risk	Labels	State variations	Special provisions	UN packing group	Excepted quantity	Passenger and cargo aircraft		Cargo aircraft only	
									Packing instruction	Max. net quantity per package	Packing instruction	Max. net quantity per package
1	2	3	4	5	6	7	8	9	10	11	12	13
Hexachloro-2-propanone, see Hexachloroacetone												
Hexadecyltrichlorosilane	1781	8		Corrosive	AU 1 CA 7 IR 3 NL 1 US 3	A1	II	E0	FORBIDDEN		876	30 L
Hexadiene	2458	3		Liquid flammable			II	E2	353 Y341	5 L 1 L	364	60 L
Hexaethyl tetraphosphate	1611	6.1		Toxic	US 4		II	E4	654 Y641	5 L 1 L	662	60 L
Hexaethyl tetraphosphate and compressed gas mixture	1612	2.3			AU 1 CA 7 IR 3 NL 1 US 3	A2			FORBIDDEN		FORBIDDEN	
Hexafluoroacetone	2420	2.3	8		AU 1 CA 7 IR 3 NL 1 US 3	A2			FORBIDDEN		FORBIDDEN	
Hexafluoroacetone hydrate, liquid	2552	6.1		Toxic			II	E4	654 Y641	5 L 1 L	662	60 L
Hexafluoroacetone hydrate, solid	3436	6.1		Toxic			II	E4	669 Y644	25 kg 1 kg	676	100 kg
Hexafluoroethane	2193	2.2		Gas non-flammable				E1	200	75 kg	200	150 kg
Hexafluorophosphoric acid	1782	8		Corrosive			II	E2	851 Y840	1 L 0.5 L	855	30 L
Hexafluoropropylene	1858	2.2		Gas non-flammable				E1	200	75 kg	200	150 kg
Hexahydrocresol, see Methylcyclohexanols , etc.												
Hexahydromethyl phenol, see Methylcyclohexanols , etc.												
Hexaldehyde	1207	3		Liquid flammable			III	E1	355 Y344	60 L 10 L	366	220 L
3,3,6,6,9,9-Hexamethyl-1,2,4,5 tetra-oxacyclononane, more than 52%	FORBIDDEN											
Hexamethylenediamine, solid	2280	8		Corrosive			III	E1	860 Y845	25 kg 5 kg	864	100 kg

Chapter 2

3-2-111

Name	UN No.	Class or division	Subsidiary risk	Labels	State variations	Special provisions	UN packing group	Excepted quantity	Passenger and cargo aircraft		Cargo aircraft only	
									Packing instruction	Max. net quantity per package	Packing instruction	Max. net quantity per package
1	2	3	4	5	6	7	8	9	10	11	12	13
Hexamethylenediamine solution	1783	8		Corrosive		A3	II	E2	851 Y840	1 L 0.5 L	855	30 L
							III	E1	852 Y841	5 L 1 L	856	60 L
Hexamethylene diisocyanate	2281	6.1		Toxic			II	E4	654 Y641	5 L 1 L	662	60 L
Hexamethyleneimine	2493	3	8	Liquid flammable & Corrosive			II	E2	352 Y340	1 L 0.5 L	363	5 L
Hexamethylenetetramine	1328	4.1		Solid flammable			III	E1	446 Y443	25 kg 10 kg	449	100 kg
Hexamethylene triperoxide diamine (dry)	FORBIDDEN											
Hexamethylol benzene hexanitrate	FORBIDDEN											
Hexamine, see Hexamethylenetetramine												
Hexanes	1208	3		Liquid flammable			II	E2	353 Y341	5 L 1 L	364	60 L
Hexanitroazoxy benzene	FORBIDDEN											
2,2',4,4',6,6'-Hexanitro-3,3'-dihydroxyazobenzene (dry)	FORBIDDEN											
Hexanitrodiphenylamine	0079	1.1D							FORBIDDEN		FORBIDDEN	
2,3',4,4',6,6'-Hexanitrodiphenylether	FORBIDDEN											
N,N' (Hexanitrodiphenyl) ethylene dinitramine (dry)	FORBIDDEN											
Hexanitrodiphenyl urea	FORBIDDEN											
Hexanitroethane	FORBIDDEN											
Hexanitrooxanilide	FORBIDDEN											
Hexanitrostilbene	0392	1.1D							FORBIDDEN		FORBIDDEN	
Hexanoic acid, see Caproic acid												
Hexanols	2282	3		Liquid flammable			III	E1	355 Y344	60 L 10 L	366	220 L
1-Hexene	2370	3		Liquid flammable			II	E2	353 Y341	5 L 1 L	364	60 L

Name	UN No.	Class or division	Subsidiary risk	Labels	State variations	Special provisions	UN packing group	Excepted quantity	Passenger and cargo aircraft		Cargo aircraft only	
									Packing instruction	Max. net quantity per package	Packing instruction	Max. net quantity per package
1	2	3	4	5	6	7	8	9	10	11	12	13
Hexogen and cyclotetramethylene-tetranitramine mixture, desensitized with not less than 10% phlegmatizer, by mass	0391	1.1D							FORBIDDEN		FORBIDDEN	
Hexogen and cyclotetramethylene-tetranitramine mixture, wetted with not less than 15% water, by mass	0391	1.1D							FORBIDDEN		FORBIDDEN	
Hexogen, desensitized	0483	1.1D							FORBIDDEN		FORBIDDEN	
Hexogen, wetted with not less than 15% water, by mass	0072	1.1D							FORBIDDEN		FORBIDDEN	
Hexolite , dry or wetted with less than 15% water, by mass	0118	1.1D							FORBIDDEN		FORBIDDEN	
Hexotol , dry or wetted with less than 15% water, by mass	0118	1.1D							FORBIDDEN		FORBIDDEN	
Hexotonal	0393	1.1D							FORBIDDEN		FORBIDDEN	
Hexyl	0079	1.1D							FORBIDDEN		FORBIDDEN	
Hexyltrichlorosilane	1784	8		Corrosive	AU 1 CA 7 IR 3 NL 1 US 3	A1	II	E0	FORBIDDEN		876	30 L
High explosives, see individual explosives' entries												
HMX, desensitized	0484	1.1D							FORBIDDEN		FORBIDDEN	
HMX (dry or unphlegmatized)	FORBIDDEN											
HMX, wetted with not less than 15% water, by mass	0226	1.1D							FORBIDDEN		FORBIDDEN	
Hydrazine, anhydrous	2029	8	3 6.1	Corrosive & Liquid flammable & Toxic	US 4		I	E0	FORBIDDEN		854	2.5 L
Hydrazine, aqueous solution with more than 37% hydrazine by mass	2030	8	6.1	Corrosive & Toxic	AU 1 CA 7 IR 3 NL 1 US 3	A1 A36	I II III	E0 E0 E1	FORBIDDEN FORBIDDEN 852 Y841	5 L 1 L	854 855 856	2.5 L 30 L 60 L
Hydrazine, aqueous solution with not more than 37% hydrazine, by mass	3293	6.1		Toxic		A3	III	E1	655 Y642	60 L 2 L	663	220 L

Name	UN No.	Class or division	Subsidiary risk	Labels	State variations	Special provisions	UN packing group	Excepted quantity	Passenger and cargo aircraft		Cargo aircraft only	
									Packing instruction	Max. net quantity per package	Packing instruction	Max. net quantity per package
1	2	3	4	5	6	7	8	9	10	11	12	13
Hydrazine aqueous solution, flammable with more than 37% hydrazine, by mass	3484	8	3 6.1	Corrosive & Liquid flammable & Toxic	AU 1 CA 7 IR 3 NL 1 US 3	A1	I	E0	FORBIDDEN		854	2.5 L
Hydrazine azide									FORBIDDEN			
Hydrazine chlorate									FORBIDDEN			
Hydrazine dicarbonic acid diazide									FORBIDDEN			
Hydrazine perchlorate									FORBIDDEN			
Hydrazine selenate									FORBIDDEN			
Hydrides, metal, water-reactive, n.o.s., see Metal hydrides, water-reactive, n.o.s.												
Hydriodic acid	1787	8		Corrosive		A3	II III	E2 E1	851 Y840 852 Y841	1 L 0.5 L 5 L 1 L	855 856	30 L 60 L
Hydriodic acid, anhydrous, see Hydrogen iodide, anhydrous												
Hydrobromic acid , more than 49% strength	1788	8			AU 1 CA 7 IR 3 NL 1 US 3	A2			FORBIDDEN		FORBIDDEN	
Hydrobromic acid , not more than 49% strength	1788	8		Corrosive		A3	II III	E2 E1	851 Y840 852 Y841	1 L 0.5 L 5 L 1 L	855 856	30 L 60 L
Hydrocarbon gas mixture, compressed, n.o.s.*	1964	2.1		Gas flammable	AU 1 CA 7 IR 3 NL 1 US 3	A1		E0	FORBIDDEN		200	150 kg
Hydrocarbon gas mixture, liquefied, n.o.s.*	1965	2.1		Gas flammable	AU 1 CA 7 IR 3 NL 1 US 3	A1		E0	FORBIDDEN		200	150 kg

Name	UN No.	Class or division	Subsidiary risk	Labels	State variations	Special provisions	UN packing group	Excepted quantity	Passenger and cargo aircraft		Cargo aircraft only	
									Packing instruction	Max. net quantity per package	Packing instruction	Max. net quantity per package
1	2	3	4	5	6	7	8	9	10	11	12	13
Hydrocarbon gas powered small devices, see Devices, small, hydrocarbon gas powered with release device												
Hydrocarbon gas refills for small devices with release device	3150	2.1		Gas flammable				E0	201	1 kg	201	15 kg
Hydrocarbons, liquid, n.o.s.	3295	3		Liquid flammable		A3	I	E3	351	1 L	361	30 L
							II	E2	353	5 L	364	60 L
									Y341	1 L		
							III	E1	355	60 L	366	220 L
									Y344	10 L		
Hydrochloric acid	1789	8		Corrosive		A3	II	E2	851	1 L	855	30 L
							III	E1	Y840	0.5 L	856	60 L
									852	5 L		
									Y841	1 L		
Hydrocyanic acid, aqueous solution with not more than 20% hydrogen cyanide	1613	6.1							FORBIDDEN		FORBIDDEN	
Hydrofluoric acid , with more than 60% strength	1790	8	6.1	Corrosive & Toxic			I	E0	850	0.5 L	854	2.5 L
Hydrofluoric acid , with not more than 60% strength	1790	8	6.1	Corrosive & Toxic			II	E2	851	1 L	855	30 L
									Y840	0.5 L		
Hydrofluoric acid and sulphuric acid mixture	1786	8	6.1	Corrosive & Toxic	AU 1 CA 7 IR 3 NL 1 US 3	A1	I	E0	FORBIDDEN		854	2.5 L
Hydrofluoroboric acid, see Fluoroboric acid												
Hydrofluosilicic acid, see Fluorosilicic acid												
Hydrogen and methane mixture, compressed	2034	2.1		Gas flammable	AU 1 CA 7 IR 3 NL 1 US 3	A1		E0	FORBIDDEN		200	150 kg
Hydrogen arsenide, see Arsine												
Hydrogen bromide, anhydrous	1048	2.3	8		AU 1 CA 7 IR 3 NL 1 US 3	A2			FORBIDDEN		FORBIDDEN	

Name	UN No.	Class or division	Subsidiary risk	Labels	State variations	Special provisions	UN packing group	Excepted quantity	Passenger and cargo aircraft		Cargo aircraft only	
									Packing instruction	Max. net quantity per package	Packing instruction	Max. net quantity per package
1	2	3	4	5	6	7	8	9	10	11	12	13
Hydrogen bromide solution, see Hydrobromic acid (UN No. 1788)												
Hydrogen chloride, anhydrous	1050	2.3	8		AU 1 CA 7 IR 3 NL 1 US 3	A2			FORBIDDEN		FORBIDDEN	
Hydrogen chloride, refrigerated liquid	2186	2.3	8						FORBIDDEN		FORBIDDEN	
Hydrogen, compressed	1049	2.1		Gas flammable	AU 1 CA 7 IR 3 NL 1 US 3	A1		E0	FORBIDDEN		200	150 kg
Hydrogen cyanide, aqueous solution with not more than 20% hydrogen cyanide	1613	6.1							FORBIDDEN		FORBIDDEN	
Hydrogen cyanide, solution in alcohol with not more than 45% hydrogen cyanide	3294	6.1	3						FORBIDDEN		FORBIDDEN	
Hydrogen cyanide, stabilized containing less than 3% water	1051	6.1	3						FORBIDDEN		FORBIDDEN	
Hydrogen cyanide, stabilized containing less than 3% water and absorbed in a porous inert material	1614	6.1							FORBIDDEN		FORBIDDEN	
Hydrogen cyanide, unstabilized	FORBIDDEN											
Hydrogendifluorides, solid, n.o.s.	1740	8		Corrosive		A3	II	E2	859 Y844	15 kg 5 kg	863	50 kg
							III	E1	860 Y845	25 kg 5 kg	864	100 kg
Hydrogendifluorides, solution, n.o.s.	3471	8	6.1	Corrosive & Toxic		A3	II	E2	851 Y840	1 L 0.5 L	855	30 L
							III	E1	852 Y841	5 L 1 L	856	60 L
Hydrogen fluoride, anhydrous	1052	8	6.1		AU 1 CA 7 IR 3 NL 1 US 3	A2			FORBIDDEN		FORBIDDEN	
Hydrogen fluoride solution, see Hydrofluoric acid , etc.												

Name	UN No.	Class or division	Subsidiary risk	Labels	State variations	Special provisions	UN packing group	Excepted quantity	Passenger and cargo aircraft		Cargo aircraft only	
									Packing instruction	Max. net quantity per package	Packing instruction	Max. net quantity per package
1	2	3	4	5	6	7	8	9	10	11	12	13
Hydrogen in a metal hydride storage system	3468	2.1		Gas flammable	AU 1 CA 7 IR 3 NL 1 US 3	A1 A143 A176		E0	FORBIDDEN		214	100 kg
Hydrogen in a metal hydride storage system contained in equipment	3468	2.1		Gas flammable	AU 1 CA 7 IR 3 NL 1 US 3	A1 A143 A176		E0	FORBIDDEN		214	100 kg
Hydrogen in a metal hydride storage system packed with equipment	3468	2.1		Gas flammable	AU 1 CA 7 IR 3 NL 1 US 3	A1 A143 A176		E0	FORBIDDEN		214	100 kg
Hydrogen iodide, anhydrous	2197	2.3	8		AU 1 CA 7 IR 3 NL 1 US 3	A2			FORBIDDEN		FORBIDDEN	
Hydrogen iodide solution, see Hydriodic acid												
Hydrogen peroxide and peroxyacetic acid mixture with acid(s), water and not more than 5% peroxyacetic acid, stabilized	3149	5.1	8	Oxidizer & Corrosive		A96	II	E2	550 Y540	1 L 0.5 L	554	5 L
Hydrogen peroxide, aqueous solution with more than 40% but not more than 60% hydrogen peroxide (stabilized as necessary)	2014	5.1	8		AU 1 CA 7 IR 3 NL 1 US 3	A2 A75			FORBIDDEN		FORBIDDEN	
Hydrogen peroxide, aqueous solution with not less than 8% but less than 20% hydrogen peroxide (stabilized as necessary)	2984	5.1		Oxidizer			III	E1	551 Y541	2.5 L 1 L	555	30 L
Hydrogen peroxide, aqueous solution with not less than 20% but not more than 40% hydrogen peroxide (stabilized as necessary)	2014	5.1	8	Oxidizer & Corrosive			II	E2	550 Y540	1 L 0.5 L	554	5 L
Hydrogen peroxide, aqueous solution, stabilized with more than 60% hydrogen peroxide	2015	5.1	8						FORBIDDEN		FORBIDDEN	
Hydrogen peroxide, stabilized	2015	5.1	8						FORBIDDEN		FORBIDDEN	
Hydrogen, refrigerated liquid	1966	2.1							FORBIDDEN		FORBIDDEN	

Chapter 2

3-2-117

Name	UN No.	Class or division	Subsidiary risk	Labels	State variations	Special provisions	UN packing group	Excepted quantity	Passenger and cargo aircraft		Cargo aircraft only	
									Packing instruction	Max. net quantity per package	Packing instruction	Max. net quantity per package
1	2	3	4	5	6	7	8	9	10	11	12	13
Hydrogen selenide, adsorbed	3526	2.3	2.1			A2		E0	FORBIDDEN		FORBIDDEN	
Hydrogen selenide, anhydrous	2202	2.3	2.1		AU 1 CA 7 IR 3 NL 1 US 3	A2			FORBIDDEN		FORBIDDEN	
Hydrogen silicide, see Silane												
Hydrogen sulphide	1053	2.3	2.1		AU 1 CA 7 IR 3 NL 1 US 3	A2			FORBIDDEN		FORBIDDEN	
Hydroselenic acid, see Hydrogen selenide, anhydrous												
Hydrosilicofluoric acid, see Fluorosilicic acid												
1-Hydroxybenzotriazole, anhydrous , dry or wetted with less than 20% water, by mass	0508	1.3C							FORBIDDEN		FORBIDDEN	
1-Hydroxybenzotriazole monohydrate	3474	4.1		Solid flammable	BE 3		I	E0	451	0.5 kg	451	0.5 kg
3-Hydroxybutan-2-one, see Acetyl methyl carbinol												
Hydroxyl amine iodide	FORBIDDEN											
Hydroxylamine sulphate	2865	8		Corrosive			III	E1	860 Y845	25 kg 5 kg	864	100 kg
1-Hydroxy-3-methyl-2-penten-4-yne, see 1-Pentol												
3-Hydroxyphenol, see Resorcinol												
Hypochlorites, inorganic, n.o.s.*	3212	5.1		Oxidizer		A169	II	E2	558 Y544	5 kg 2.5 kg	562	25 kg
Hypochlorite solution †	1791	8		Corrosive		A3	II	E2	851 Y840	1 L 0.5 L	855	30 L
							III	E1	852 Y841	5 L 1 L	856	60 L
Hyponitrous acid	FORBIDDEN											

Name	UN No.	Class or division	Subsidiary risk	Labels	State variations	Special provisions	UN packing group	Excepted quantity	Passenger and cargo aircraft		Cargo aircraft only	
									Packing instruction	Max. net quantity per package	Packing instruction	Max. net quantity per package
1	2	3	4	5	6	7	8	9	10	11	12	13
I												
Igniters †	0121	1.1G							FORBIDDEN		FORBIDDEN	
Igniters †	0314	1.2G							FORBIDDEN		FORBIDDEN	
Igniters †	0315	1.3G							FORBIDDEN		FORBIDDEN	
Igniters †	0325	1.4G		Explosive 1.4				E0	FORBIDDEN		142	75 kg
Igniters †	0454	1.4S		Explosive 1.4				E0	142	25 kg	142	100 kg
Ignition element for lighter, containing pyrophoric liquid	FORBIDDEN											
3,3'-Iminodipropylamine	2269	8		Corrosive			III	E1	852 Y841	5 L 1 L	856	60 L
Indiarubber, see Rubber solution												
≠ Infectious substance, affecting animals only	2900	6.2		Infectious	AU 3 CA 8 GB 5 VU 2	A81 A140		E0	620	50 mL or 50 g	620	4 L or 4 kg
≠ Infectious substance, affecting humans	2814	6.2		Infectious	AU 3 CA 8 GB 5 VU 2	A81 A140		E0	620	50 mL or 50 g	620	4 L or 4 kg
Inflammable, see Flammable												
Ink, printer's, flammable, see Printing ink												
Inositol hexanitrate (dry)	FORBIDDEN											
Insecticide, see appropriate pesticide												
Insecticide gas, n.o.s.*	1968	2.2		Gas non-flammable				E1	200	75 kg	200	150 kg
Insecticide gas, flammable, n.o.s.*	3354	2.1		Gas flammable	AU 1 CA 7 IR 3 NL 1 US 3	A1		E0	FORBIDDEN		200	150 kg
Insecticide gas, toxic, n.o.s.*	1967	2.3			AU 1 CA 7 IR 3 NL 1 US 3	A2			FORBIDDEN		FORBIDDEN	

Name	UN No.	Class or division	Subsidiary risk	Labels	State variations	Special provisions	UN packing group	Excepted quantity	Passenger and cargo aircraft		Cargo aircraft only	
									Packing instruction	Max. net quantity per package	Packing instruction	Max. net quantity per package
1	2	3	4	5	6	7	8	9	10	11	12	13
Insecticide gas, toxic, flammable, n.o.s.*	3355	2.3	2.1		AU 1 CA 7 IR 3 NL 1 US 3	A2			FORBIDDEN		FORBIDDEN	
Inulin trinitrate (dry)	FORBIDDEN											
Iodine	3495	8	6.1	Corrosive & Toxic		A113	III	E1	860 Y845	25 kg 5 kg	864	100 kg
Iodine azide (dry)	FORBIDDEN											
Iodine monochloride, liquid	3498	8		Corrosive			II	E0	FORBIDDEN		855	30 L
Iodine monochloride, solid	1792	8		Corrosive	AU 1 CA 7 IR 3 NL 1 US 3	A1	II	E0	FORBIDDEN		863	50 kg
Iodine pentafluoride	2495	5.1	6.1 8						FORBIDDEN		FORBIDDEN	
2-Iodobutane	2390	3		Liquid flammable			II	E2	353 Y341	5 L 1 L	364	60 L
Iodomethane, see Methyl iodide												
Iodomethylpropanes	2391	3		Liquid flammable			II	E2	353 Y341	5 L 1 L	364	60 L
Iodopropanes	2392	3		Liquid flammable			III	E1	355 Y344	60 L 10 L	366	220 L
alpha-Iodotoluene, see Benzyl iodide												
Iodoxy compounds (dry)	FORBIDDEN											
IPDI, see Isophorone diisocyanate												
Iridium nitratopentamine iridium nitrate	FORBIDDEN											
Iron chloride, anhydrous, see Ferric chloride, anhydrous												
Iron (III) chloride, anhydrous, see Ferric chloride, anhydrous												

Name	UN No.	Class or division	Subsidiary risk	Labels	State variations	Special provisions	UN packing group	Excepted quantity	Passenger and cargo aircraft		Cargo aircraft only	
									Packing instruction	Max. net quantity per package	Packing instruction	Max. net quantity per package
1	2	3	4	5	6	7	8	9	10	11	12	13
Iron chloride solution, see Ferric chloride solution												
Iron oxide, spent † (obtained from coal gas purification)	1376	4.2			AU 1 CA 7 IR 3 NL 1 US 3	A2 A3			FORBIDDEN		FORBIDDEN	
Iron pentacarbonyl	1994	6.1	3						FORBIDDEN		FORBIDDEN	
Iron perchloride, anhydrous, see Ferric chloride, anhydrous												
Iron powder, pyrophoric, see Pyrophoric metal, n.o.s. or Pyrophoric alloy, n.o.s.												
Iron sesquichloride, anhydrous, see Ferric chloride, anhydrous												
Iron sponge, spent † (obtained from coal gas purification)	1376	4.2			AU 1 CA 7 IR 3 NL 1 US 3	A2 A3			FORBIDDEN		FORBIDDEN	
Iron swarf, see Ferrous metal, borings, cuttings, shavings or turnings , etc.												
Irritating agents, see Tear gas substance , etc.												
Isobutane	1969	2.1		Gas flammable	AU 1 CA 7 IR 3 NL 1 US 3	A1		E0	FORBIDDEN		200	150 kg
Isobutanol	1212	3		Liquid flammable			III	E1	355 Y344	60 L 10 L	366	220 L
Isobutene, see Isobutylene												
Isobutyl acetate	1213	3		Liquid flammable			II	E2	353 Y341	5 L 1 L	364	60 L
Isobutyl acrylate, stabilized	2527	3		Liquid flammable			III	E1	355 Y344	60 L 10 L	366	220 L
Isobutyl alcohol	1212	3		Liquid flammable			III	E1	355 Y344	60 L 10 L	366	220 L

Name	UN No.	Class or division	Subsidiary risk	Labels	State variations	Special provisions	UN packing group	Excepted quantity	Passenger and cargo aircraft		Cargo aircraft only	
									Packing instruction	Max. net quantity per package	Packing instruction	Max. net quantity per package
1	2	3	4	5	6	7	8	9	10	11	12	13
Isobutyl aldehyde	2045	3		Liquid flammable			II	E2	353 Y341	5 L 1 L	364	60 L
Isobutylamine	1214	3	8	Liquid flammable & Corrosive			II	E2	352 Y340	1 L 0.5 L	363	5 L
Isobutylene	1055	2.1		Gas flammable	AU 1 CA 7 IR 3 NL 1 US 3	A1		E0	FORBIDDEN		200	150 kg
Isobutyl formate	2393	3		Liquid flammable			II	E2	353 Y341	5 L 1 L	364	60 L
Isobutyl isobutyrate	2528	3		Liquid flammable			III	E1	355 Y344	60 L 10 L	366	220 L
Isobutyl isocyanate	2486	6.1	3		US 2				FORBIDDEN		FORBIDDEN	
Isobutyl methacrylate, stabilized	2283	3		Liquid flammable			III	E1	355 Y344	60 L 10 L	366	220 L
Isobutyl propionate	2394	3		Liquid flammable			III	E1	355 Y344	60 L 10 L	366	220 L
Isobutyraldehyde	2045	3		Liquid flammable			II	E2	353 Y341	5 L 1 L	364	60 L
Isobutyric acid	2529	3	8	Liquid flammable & Corrosive			III	E1	354 Y342	5 L 1 L	365	60 L
Isobutyronitrile	2284	3	6.1	Liquid flammable & Toxic			II	E2	352 Y341	1 L 1 L	364	60 L
Isobutyryl chloride	2395	3	8	Liquid flammable & Corrosive			II	E2	352 Y340	1 L 0.5 L	363	5 L
Isocyanates, flammable, toxic, n.o.s.* †	2478	3	6.1	Liquid flammable & Toxic		A3	II	E2	352 Y341	1 L 1 L	364	60 L
							III	E1	355 Y343	60 L 2 L	366	220 L
Isocyanate solution, flammable, toxic, n.o.s.* †	2478	3	6.1	Liquid flammable & Toxic		A3	II	E2	352 Y341	1 L 1 L	364	60 L
							III	E1	355 Y343	60 L 2 L	366	220 L
Isocyanate solution, toxic, n.o.s.* †	2206	6.1		Toxic		A3	II	E4	654 Y641	5 L 1 L	662	60 L
							III	E1	655 Y642	60 L 2 L	663	220 L
Isocyanate solution, toxic, flammable, n.o.s.* †	3080	6.1	3	Toxic & Liquid flammable			II	E4	654 Y641	5 L 1 L	662	60 L

Name	UN No.	Class or division	Subsidiary risk	Labels	State variations	Special provisions	UN packing group	Excepted quantity	Passenger and cargo aircraft		Cargo aircraft only	
									Packing instruction	Max. net quantity per package	Packing instruction	Max. net quantity per package
1	2	3	4	5	6	7	8	9	10	11	12	13
Isocyanates, toxic, n.o.s.* †	2206	6.1		Toxic		A3	II	E4	654	5 L	662	60 L
									Y641	1 L		
									655	60 L		
									Y642	2 L		
Isocyanates, toxic, flammable, n.o.s.* †	3080	6.1	3	Toxic & Liquid flammable			II	E4	654 Y641	5 L 1 L	662	60 L
Isocyanatobenzotrifluorides	2285	6.1	3	Toxic & Liquid flammable			II	E4	654 Y641	5 L 1 L	662	60 L
3-Isocyanatomethyl-3,5,5-trimethylcyclohexyl isocyanate, see Isophorone diisocyanate												
Isododecane, see Pentamethylheptane												
Isoheptene	2287	3		Liquid flammable			II	E2	353 Y341	5 L 1 L	364	60 L
Isohexene	2288	3		Liquid flammable			II	E2	353 Y341	5 L 1 L	364	60 L
Isooctane, see Octanes												
Isooctene	1216	3		Liquid flammable			II	E2	353 Y341	5 L 1 L	364	60 L
Isopentane, see Pentanes , liquid												
Isopentenenes	2371	3		Liquid flammable			I	E3	351	1 L	361	30 L
Isopentylamine, see Amylamine												
Isopentyl nitrite, see Amyl nitrite												
Isophoronediamine	2289	8		Corrosive			III	E1	852 Y841	5 L 1 L	856	60 L
Isophorone diisocyanate	2290	6.1		Toxic			III	E1	655 Y642	60 L 2 L	663	220 L
Isoprene, stabilized	1218	3		Liquid flammable			I	E3	351	1 L	361	30 L
Isopropanol	1219	3		Liquid flammable		A180	II	E2	353 Y341	5 L 1 L	364	60 L
Isopropenyl acetate	2403	3		Liquid flammable			II	E2	353 Y341	5 L 1 L	364	60 L
Isopropenylbenzene	2303	3		Liquid flammable			III	E1	355 Y344	60 L 10 L	366	220 L
Isopropyl acetate	1220	3		Liquid flammable			II	E2	353 Y341	5 L 1 L	364	60 L

Name	UN No.	Class or division	Subsidiary risk	Labels	State variations	Special provisions	UN packing group	Excepted quantity	Passenger and cargo aircraft		Cargo aircraft only	
									Packing instruction	Max. net quantity per package	Packing instruction	Max. net quantity per package
1	2	3	4	5	6	7	8	9	10	11	12	13
Isopropyl acid phosphate	1793	8		Corrosive			III	E1	852 Y841	5 L 1 L	856	60 L
Isopropyl alcohol	1219	3		Liquid flammable		A180	II	E2	353 Y341	5 L 1 L	364	60 L
Isopropylamine	1221	3	8	Liquid flammable & Corrosive			I	E0	350	0.5 L	360	2.5 L
Isopropylbenzene	1918	3		Liquid flammable			III	E1	355 Y344	60 L 10 L	366	220 L
Isopropyl sec-butyl peroxydicarbonate, not more than 52%, with di-sec-butyl peroxydicarbonate, not more than 28%, with di-isopropyl peroxydicarbonate, not more than 22%	FORBIDDEN											
Isopropyl butyrate	2405	3		Liquid flammable			III	E1	355 Y344	60 L 10 L	366	220 L
Isopropyl chloride, see 2-Chloropropane												
Isopropyl chloroacetate	2947	3		Liquid flammable			III	E1	355 Y344	60 L 10 L	366	220 L
Isopropyl chloroformate	2407	6.1	3 8		AU 1 CA 7 IR 3 NL 1 US 3	A2			FORBIDDEN		FORBIDDEN	
Isopropyl 2-chloropropionate	2934	3		Liquid flammable			III	E1	355 Y344	60 L 10 L	366	220 L
Isopropyl-alpha-chloropropionate, see Isopropyl 2-chloropropionate												
Isopropylcumyl hydroperoxide, more than 72% in solution	FORBIDDEN											
Isopropyl ether, see Diisopropyl ether												
Isopropylethylene, see 3-Methyl-1-butene												
Isopropyl formate, see Propyl formates												
Isopropyl isobutyrate	2406	3		Liquid flammable			II	E2	353 Y341	5 L 1 L	364	60 L
Isopropyl isocyanate	2483	6.1	3						FORBIDDEN		FORBIDDEN	

Name	UN No.	Class or division	Subsidiary risk	Labels	State variations	Special provisions	UN packing group	Excepted quantity	Passenger and cargo aircraft		Cargo aircraft only	
									Packing instruction	Max. net quantity per package	Packing instruction	Max. net quantity per package
1	2	3	4	5	6	7	8	9	10	11	12	13
Isopropyl mercaptan, see Propanethiols												
Isopropyl nitrate	1222	3		Liquid flammable			II	E2	353 Y341	5 L 1 L	364	60 L
Isopropyl propionate	2409	3		Liquid flammable			II	E2	353 Y341	5 L 1 L	364	60 L
Isopropyltoluene, see Cymenes												
Isopropyltoluol, see Cymenes												
Isosorbide dinitrate mixture with not less than 60% lactose, mannose, starch or calcium hydrogen phosphate	2907	4.1		Solid flammable	BE 3	A49	II	E0	445	15 kg	448	50 kg
Isosorbide-5-mononitrate	3251	4.1				A110			FORBIDDEN		FORBIDDEN	
Isothiocyanic acid	FORBIDDEN											
Isovaleraldehyde, see Valeraldehyde												
J												
Jet fuel, see Fuel, aviation, turbine engine												
Jet perforating guns, charged , oil well, without detonator †	0124	1.1D							FORBIDDEN		FORBIDDEN	
Jet perforating guns, charged , oil well, without detonator †	0494	1.4D		Explosive 1.4		A24		E0	FORBIDDEN		101	300 kg
Jet tappers, without detonator, see Charges, shaped (UN Nos. 0059, 0439, 0440, 0441)												
K												
Kerosene	1223	3		Liquid flammable			III	E1	355 Y344	60 L 10 L	366	220 L
Ketones, liquid, n.o.s.*	1224	3		Liquid flammable		A3	II	E2	353 Y341	5 L 1 L	364	60 L
							III	E1	355 Y344	60 L 10 L	366	220 L
+ Krill meal	3497	4.2		Spontaneous combustion		A3	II	E2	467	15 kg	470	50 kg
							III	E1	469	25 kg	471	100 kg
Krypton, compressed	1056	2.2		Gas non-flammable		A69		E1	200	75 kg	200	150 kg

Name	UN No.	Class or division	Subsidiary risk	Labels	State variations	Special provisions	UN packing group	Excepted quantity	Passenger and cargo aircraft		Cargo aircraft only	
									Packing instruction	Max. net quantity per package	Packing instruction	Max. net quantity per package
1	2	3	4	5	6	7	8	9	10	11	12	13
Krypton, refrigerated liquid	1970	2.2		Gas non-flammable				E1	202	50 kg	202	500 kg
L												
Lacquer base or lacquer chips, nitrocellulose, dry †, see Nitrocellulose , etc. (UN No. 2557)												
Lacquer base or lacquer chips, plastic, wet with alcohol or solvent, see Nitrocellulose (UN Nos. 2059, 2555, 2556) or Paint , etc. (UN No. 1263)												
Lead acetate	1616	6.1		Toxic			III	E1	670 Y645	100 kg 10 kg	677	200 kg
Lead (II) acetate, see Lead acetate												
Lead arsenates	1617	6.1		Toxic	US 4		II	E4	669 Y644	25 kg 1 kg	676	100 kg
Lead arsenites	1618	6.1		Toxic			II	E4	669 Y644	25 kg 1 kg	676	100 kg
Lead azide (dry)	FORBIDDEN											
Lead azide, wetted with not less than 20% water, or mixture of alcohol and water, by mass	0129	1.1A							FORBIDDEN		FORBIDDEN	
Lead chloride, solid, see Lead compound, soluble, n.o.s.												
Lead compound, soluble, n.o.s.*	2291	6.1		Toxic		A92	III	E1	670 Y645	100 kg 10 kg	677	200 kg
Lead cyanide	1620	6.1		Toxic			II	E4	669 Y644	25 kg 1 kg	676	100 kg
Lead (II) cyanide, see Lead cyanide												
Lead dioxide	1872	5.1		Oxidizer			III	E1	559 Y546	25 kg 10 kg	563	100 kg
Lead nitrate	1469	5.1	6.1	Oxidizer & Toxic			II	E2	558 Y543	5 kg 1 kg	562	25 kg
Lead (II) nitrate, see Lead nitrate												
Lead nitroresorcinate (dry)	FORBIDDEN											

Name	UN No.	Class or division	Subsidiary risk	Labels	State variations	Special provisions	UN packing group	Excepted quantity	Passenger and cargo aircraft		Cargo aircraft only	
									Packing instruction	Max. net quantity per package	Packing instruction	Max. net quantity per package
1	2	3	4	5	6	7	8	9	10	11	12	13
Lead (II) perchlorate, see Lead perchlorate, solid (UN No. 1470) or Lead perchlorate solution (UN No. 3408)												
Lead perchlorate, solid	1470	5.1	6.1	Oxidizer & Toxic			II	E2	558 Y543	5 kg 1 kg	562	25 kg
Lead perchlorate solution	3408	5.1	6.1	Oxidizer & Toxic		A3	II III	E2 E1	550 Y540 551 Y541	1 L 0.5 L 2.5 L 1 L	554 555	5 L 30 L
Lead peroxide, see Lead dioxide												
Lead phosphite, dibasic	2989	4.1		Solid flammable		A3	II III	E2 E1	445 Y441 446 Y443	15 kg 5 kg 25 kg 10 kg	448 449	50 kg 100 kg
Lead picrate (dry)	FORBIDDEN											
Lead styphnate (dry)	FORBIDDEN											
Lead styphnate, wetted with not less than 20% water, or mixture of alcohol and water, by mass	0130	1.1A							FORBIDDEN		FORBIDDEN	
Lead sulphate with more than 3% free acid	1794	8		Corrosive	US 4		II	E2	859 Y844	15 kg 5 kg	863	50 kg
Lead tetraethyl, see Motor fuel anti-knock mixture												
Lead tetramethyl, see Motor fuel anti-knock mixture												
Lead trinitroresorcinate (dry)	FORBIDDEN											
Lead trinitroresorcinate, wetted with not less than 20% water, or mixture of alcohol and water, by mass	0130	1.1A							FORBIDDEN		FORBIDDEN	
≠ Life-saving appliances, not self-inflating containing dangerous goods as equipment	3072	9		Miscellaneous		A48 A87 A182		E0	see 955	No limit	see 955	No limit
Life-saving appliances, self-inflating	2990	9		Miscellaneous		A48 A87		E0	see 955	No limit	see 955	No limit

Name	UN No.	Class or division	Subsidiary risk	Labels	State variations	Special provisions	UN packing group	Excepted quantity	Passenger and cargo aircraft		Cargo aircraft only	
									Packing instruction	Max. net quantity per package	Packing instruction	Max. net quantity per package
1	2	3	4	5	6	7	8	9	10	11	12	13
Lighter flints, see Ferrocium												
Lighter fluid, see Flammable liquid, n.o.s.												
Lighter refills containing flammable gas	1057	2.1		Gas flammable				E0	201	1 kg	201	15 kg
Lighters containing flammable gas	1057	2.1		Gas flammable	US 7			E0	201	1 kg	201	15 kg
Lighters (cigarettes) containing pyrophoric liquid	FORBIDDEN											
Lighters, fuse †	0131	1.4S		Explosive 1.4				E0	142	25 kg	142	100 kg
Lighters (cigarettes) with lighter fluids	FORBIDDEN											
Limonene, inactive, see Dipentene												
Liquefied gas, n.o.s.*	3163	2.2		Gas non-flammable				E1	200	75 kg	200	150 kg
Liquefied gases , non-flammable, charged with nitrogen, carbon dioxide or air	1058	2.2		Gas non-flammable				E1	200	75 kg	200	150 kg
Liquefied gas, flammable, n.o.s.*	3161	2.1		Gas flammable	AU 1 CA 7 IR 3 NL 1 US 3	A1		E0	FORBIDDEN		200	150 kg
Liquefied gas, oxidizing, n.o.s.*	3157	2.2	5.1	Gas non-flammable & Oxidizer	US 18			E0	200	75 kg	200	150 kg
Liquefied gas, toxic, n.o.s.*	3162	2.3			AU 1 CA 7 IR 3 NL 1 US 3	A2			FORBIDDEN		FORBIDDEN	
Liquefied gas, toxic, corrosive, n.o.s.*	3308	2.3	8		AU 1 CA 7 IR 3 NL 1 US 3	A2			FORBIDDEN		FORBIDDEN	
Liquefied gas, toxic, flammable, n.o.s.*	3160	2.3	2.1		AU 1 CA 7 IR 3 NL 1 US 3	A2			FORBIDDEN		FORBIDDEN	

Name	UN No.	Class or division	Subsidiary risk	Labels	State variations	Special provisions	UN packing group	Excepted quantity	Passenger and cargo aircraft		Cargo aircraft only	
									Packing instruction	Max. net quantity per package	Packing instruction	Max. net quantity per package
1	2	3	4	5	6	7	8	9	10	11	12	13
Liquefied gas, toxic, flammable, corrosive, n.o.s.*	3309	2.3	2.1 8		AU 1 CA 7 IR 3 NL 1 US 3	A2			FORBIDDEN		FORBIDDEN	
Liquefied gas, toxic, oxidizing, n.o.s.*	3307	2.3	5.1		AU 1 CA 7 IR 3 NL 1 US 3	A2			FORBIDDEN		FORBIDDEN	
Liquefied gas, toxic, oxidizing, corrosive, n.o.s.*	3310	2.3	5.1 8		AU 1 CA 7 IR 3 NL 1 US 3	A2			FORBIDDEN		FORBIDDEN	
Liquefied petroleum gas, see Petroleum gases, liquefied												
Liquor, see Alcoholic beverages , etc.												
Lithium	1415	4.3		Danger if wet	AU 1 CA 7 IR 3 NL 1 US 3	A1	I	E0	FORBIDDEN		487	15 kg
Lithium alkyls, liquid, see Organometallic substance, liquid, pyrophoric, water-reactive (UN No. 3394)												
Lithium alkyls, solid, see Organometallic substance, solid, pyrophoric, water-reactive (UN No. 3393)												
Lithium alloy batteries, see Lithium metal batteries , etc. (UN Nos. 3090, 3091)												
Lithium aluminium hydride	1410	4.3		Danger if wet			I	E0	FORBIDDEN		487	15 kg
Lithium aluminium hydride, ethereal	1411	4.3	3	Danger if wet & Liquid flammable			I	E0	FORBIDDEN		480	1 L
Lithium borohydride	1413	4.3		Danger if wet			I	E0	FORBIDDEN		487	15 kg
Lithium ferrosilicon	2830	4.3		Danger if wet			II	E2	484 Y475	15 kg 5 kg	490	50 kg
Lithium hydride	1414	4.3		Danger if wet			I	E0	FORBIDDEN		487	15 kg

Name	UN No.	Class or division	Subsidiary risk	Labels	State variations	Special provisions	UN packing group	Excepted quantity	Passenger and cargo aircraft		Cargo aircraft only	
									Packing instruction	Max. net quantity per package	Packing instruction	Max. net quantity per package
1	2	3	4	5	6	7	8	9	10	11	12	13
Lithium hydride, fused solid	2805	4.3		Danger if wet			II	E2	483 Y475	15 kg 5 kg	489	50 kg
Lithium hydroxide	2680	8		Corrosive			II	E2	859 Y844	15 kg 5 kg	863	50 kg
Lithium hydroxide solution	2679	8		Corrosive		A3	II	E2	851 Y840	1 L 0.5 L	855	30 L
							III	E1	852 Y841	5 L 1 L	856	60 L
Lithium hypochlorite, dry	1471	5.1		Oxidizer		A3	II	E2	558 Y544	5 kg 2.5 kg	562	25 kg
							III	E1	559 Y546	25 kg 10 kg	563	100 kg
Lithium hypochlorite mixture	1471	5.1		Oxidizer		A3	II	E2	558 Y544	5 kg 2.5 kg	562	25 kg
							III	E1	559 Y546	25 kg 10 kg	563	100 kg
Lithium in cartouches, see Lithium												
≠ Lithium ion batteries (including lithium ion polymer batteries)	3480	9		Miscellaneous	US 3	A88 A99 A154 A164 A183		E0	See 965		See 965	
≠ Lithium ion batteries contained in equipment (including lithium ion polymer batteries)	3481	9		Miscellaneous	US 3	A48 A99 A154 A164 A181 A185		E0	967	5 kg	967	35 kg
≠ Lithium ion batteries packed with equipment (including lithium ion polymer batteries)	3481	9		Miscellaneous	US 3	A88 A99 A154 A164 A181 A185		E0	966	5 kg	966	35 kg
Lithium ion polymer batteries, see Lithium ion batteries , etc. (UN Nos. 3480, 3481)												
≠ Lithium metal batteries (including lithium alloy batteries) †	3090	9		Miscellaneous	US 2 US 3	A88 A99 A154 A164 A183 A201		E0	FORBIDDEN		See 968	

Name	UN No.	Class or division	Subsidiary risk	Labels	State variations	Special provisions	UN packing group	Excepted quantity	Passenger and cargo aircraft		Cargo aircraft only	
									Packing instruction	Max. net quantity per package	Packing instruction	Max. net quantity per package
1	2	3	4	5	6	7	8	9	10	11	12	13
≠ Lithium metal batteries contained in equipment (including lithium alloy batteries) †	3091	9		Miscellaneous	US 2 US 3	A48 A99 A154 A164 A181 A185		E0	970	5 kg	970	35 kg
≠ Lithium metal batteries packed with equipment (including lithium alloy batteries) †	3091	9		Miscellaneous	US 2 US 3	A99 A154 A164 A181 A185		E0	969	5 kg	969	35 kg
Lithium nitrate	2722	5.1		Oxidizer			III	E1	559 Y546	25 kg 10 kg	563	100 kg
Lithium nitride	2806	4.3		Danger if wet			I	E0	FORBIDDEN		488	15 kg
Lithium peroxide	1472	5.1		Oxidizer			II	E2	558 Y544	5 kg 2.5 kg	562	25 kg
Lithium silicide, see Lithium silicon												
Lithium silicon †	1417	4.3		Danger if wet			II	E2	483 Y475	15 kg 5 kg	489	50 kg
LNG, see Methane, refrigerated liquid or natural gas, refrigerated liquid , etc.												
London Purple	1621	6.1		Toxic		A6	II	E4	669 Y644	25 kg 1 kg	676	100 kg
LPG, see Petroleum gases, liquefied												
Lye, see Sodium hydroxide, solid												
Lythene, see Petroleum distillates, n.o.s.												
M												
Magnesium in pellets, turnings or ribbons	1869	4.1		Solid flammable		A15	III	E1	446 Y443	25 kg 10 kg	449	100 kg
Magnesium alkyls, see Organometallic substance, liquid, pyrophoric, water-reactive (UN No. 3394)												

Name	UN No.	Class or division	Subsidiary risk	Labels	State variations	Special provisions	UN packing group	Excepted quantity	Passenger and cargo aircraft		Cargo aircraft only	
									Packing instruction	Max. net quantity per package	Packing instruction	Max. net quantity per package
1	2	3	4	5	6	7	8	9	10	11	12	13
Magnesium alloys with more than 50% magnesium in pellets, turnings or ribbons	1869	4.1		Solid flammable		A15	III	E1	446 Y443	25 kg 10 kg	449	100 kg
Magnesium alloys powder	1418	4.3	4.2	Danger if wet & Spontaneous combustion		A3	I II III	E0 E2 E1	FORBIDDEN 483 486	15 kg 25 kg	488 490 491	15 kg 50 kg 100 kg
Magnesium aluminium phosphide	1419	4.3	6.1	Danger if wet & Toxic			I	E0	FORBIDDEN		487	15 kg
Magnesium arsenate	1622	6.1		Toxic			II	E4	669 Y644	25 kg 1 kg	676	100 kg
Magnesium bisulphite solution, see Bisulphites, aqueous solution, n.o.s.												
Magnesium bromate	1473	5.1		Oxidizer			II	E2	558 Y544	5 kg 2.5 kg	562	25 kg
Magnesium chlorate	2723	5.1		Oxidizer			II	E2	558 Y544	5 kg 2.5 kg	562	25 kg
Magnesium chloride and chlorate mixture, see Chlorate and magnesium chloride mixture, solid (UN No. 1459) or Chlorate and magnesium chloride mixture solution (UN No. 3407)												
Magnesium diamide	2004	4.2		Spontaneous combustion			II	E2	467	15 kg	470	50 kg
Magnesium diphenyl, see Organometallic substance, solid, pyrophoric, water-reactive (UN No. 3393)												
Magnesium dross, wet or hot									FORBIDDEN			
Magnesium fluorosilicate	2853	6.1		Toxic			III	E1	670 Y645	100 kg 10 kg	677	200 kg
Magnesium granules, coated , particle size not less than 149 microns	2950	4.3		Danger if wet			III	E1	486 Y477	25 kg 10 kg	491	100 kg
Magnesium hydride	2010	4.3		Danger if wet			I	E0	FORBIDDEN		487	15 kg
Magnesium nitrate	1474	5.1		Oxidizer		A155	III	E1	559 Y546	25 kg 10 kg	563	100 kg
Magnesium perchlorate	1475	5.1		Oxidizer			II	E2	558 Y544	5 kg 2.5 kg	562	25 kg
Magnesium peroxide	1476	5.1		Oxidizer			II	E2	558 Y544	5 kg 2.5 kg	562	25 kg

Name	UN No.	Class or division	Subsidiary risk	Labels	State variations	Special provisions	UN packing group	Excepted quantity	Passenger and cargo aircraft		Cargo aircraft only	
									Packing instruction	Max. net quantity per package	Packing instruction	Max. net quantity per package
1	2	3	4	5	6	7	8	9	10	11	12	13
Magnesium phosphide	2011	4.3	6.1	Danger if wet & Toxic			I	E0	FORBIDDEN		487	15 kg
Magnesium powder	1418	4.3	4.2	Danger if wet & Spontaneous combustion		A3	I II III	E0 E2 E1	FORBIDDEN 483 486	15 kg 25 kg	488 490 491	15 kg 50 kg 100 kg
Magnesium scrap †, see Magnesium or Magnesium alloys (UN No. 1869)												
Magnesium silicide	2624	4.3		Danger if wet			II	E2	483 Y475	15 kg 5 kg	489	50 kg
Magnesium silicofluoride, see Magnesium fluorosilicate												
Magnetized material	2807	9		Magnetic				E0	953	No limit	953	No limit
Maleic anhydride	2215	8		Corrosive			III	E1	860 Y845	25 kg 5 kg	864	100 kg
Maleic anhydride, molten	2215	8							FORBIDDEN		FORBIDDEN	
Malonic dinitrile, see Malononitrile												
Malonodinitrile, see Malononitrile												
Malononitrile	2647	6.1		Toxic			II	E4	669 Y644	25 kg 1 kg	676	100 kg
Maneb	2210	4.2	4.3	Spontaneous combustion & Danger if wet		A30	III	E1	468	25 kg	471	100 kg
Maneb preparation with not less than 60% maneb	2210	4.2	4.3	Spontaneous combustion & Danger if wet		A30	III	E1	468	25 kg	471	100 kg
Maneb preparation, stabilized against self-heating	2968	4.3		Danger if wet		A3	III	E1	486 Y477	25 kg 10 kg	491	100 kg
Maneb stabilized against self-heating	2968	4.3		Danger if wet		A3	III	E1	486 Y477	25 kg 10 kg	491	100 kg
Manganese ethylene-di-dithiocarbamate, see Maneb												
Manganese ethylene-1,2-di-dithiocarbamate, see Maneb												
Manganese nitrate	2724	5.1		Oxidizer			III	E1	559 Y546	25 kg 10 kg	563	100 kg

Name	UN No.	Class or division	Subsidiary risk	Labels	State variations	Special provisions	UN packing group	Excepted quantity	Passenger and cargo aircraft		Cargo aircraft only	
									Packing instruction	Max. net quantity per package	Packing instruction	Max. net quantity per package
1	2	3	4	5	6	7	8	9	10	11	12	13
Manganese (II) nitrate, see Manganese nitrate												
Manganese resinate	1330	4.1		Solid flammable			III	E1	446 Y443	25 kg 10 kg	449	100 kg
Manganous nitrate, see Manganese nitrate												
Mannitan tetranitrate	FORBIDDEN											
Mannitol hexanitrate (dry)	FORBIDDEN											
Mannitol hexanitrate, wetted with not less than 40% water, or mixture of alcohol and water, by mass	0133	1.1D							FORBIDDEN		FORBIDDEN	
Matches, fusee †	2254	4.1			AU 1 CA 7 IR 3 NL 1 US 3	A2 A125			FORBIDDEN		FORBIDDEN	
Matches, safety (book, card or strike on box) †	1944	4.1		Solid flammable		A125	III	E1	455 Y455	25 kg 10 kg	455	100 kg
Matches, 'strike anywhere' †	1331	4.1			AU 1 CA 7 IR 3 NL 1 US 3	A2 A125			FORBIDDEN		FORBIDDEN	
Matches, trick, see Fireworks , etc.												
Matches, wax 'vesta'	1945	4.1		Solid flammable		A125	III	E1	455 Y455	25 kg 10 kg	455	100 kg
Medical waste, n.o.s.	3291	6.2		Infectious		A117	II	E0	622	No limit	622	No limit
Medicine, n.o.s., see Consumer commodity												
Medicine, liquid, flammable, toxic, n.o.s.	3248	3	6.1	Liquid flammable & Toxic		A3 A80	II III	E2 E1	352 Y341 355 Y343	1 L 1 L 60 L 2 L	364 366	60 L 220 L
Medicine, liquid, toxic, n.o.s.	1851	6.1		Toxic		A3	II III	E4 E1	654 Y641 655 Y642	5 L 1 L 60 L 2 L	662 663	60 L 220 L

Name	UN No.	Class or division	Subsidiary risk	Labels	State variations	Special provisions	UN packing group	Excepted quantity	Passenger and cargo aircraft		Cargo aircraft only	
									Packing instruction	Max. net quantity per package	Packing instruction	Max. net quantity per package
1	2	3	4	5	6	7	8	9	10	11	12	13
Medicine, solid, toxic, n.o.s.	3249	6.1		Toxic		A3	II	E4	669 Y644	25 kg 1 kg	676	100 kg
							III	E1	670 Y645	100 kg 10 kg	677	200 kg
p-Mentha-1,8-diene, see Dipentene												
Mercaptan mixture, liquid, flammable, n.o.s.*	3336	3		Liquid flammable		A3	I	E0	FORBIDDEN		361	30 L
							II	E2	353 Y341	5 L 1 L	364	60 L
							III	E1	355 Y344	60 L 10 L	366	220 L
Mercaptan mixture, liquid, flammable, toxic, n.o.s.*	1228	3	6.1	Liquid flammable & Toxic	AU 1 CA 7 IR 3 NL 1 US 3	A1 A3 A36	II	E0	FORBIDDEN		373	60 L
							III	E1	373 Y373	5 L 1 L	373	220 L
Mercaptan mixture, liquid, toxic, flammable, n.o.s.*	3071	6.1	3	Toxic & Liquid flammable			II	E4	654 Y641	5 L 1 L	661	60 L
Mercaptans, liquid, flammable, n.o.s.*	3336	3		Liquid flammable		A3	I	E0	FORBIDDEN		361	30 L
							II	E2	353 Y341	5 L 1 L	364	60 L
							III	E1	355 Y344	60 L 10 L	366	220 L
Mercaptans, liquid, flammable, toxic, n.o.s.*	1228	3	6.1	Liquid flammable & Toxic	AU 1 CA 7 IR 3 NL 1 US 3	A1 A3 A36	II	E0	FORBIDDEN		373	60 L
							III	E1	373 Y373	5 L 1 L	373	220 L
Mercaptans, liquid, toxic, flammable, n.o.s.*	3071	6.1	3	Toxic & Liquid flammable			II	E4	654 Y641	5 L 1 L	661	60 L
2-Mercaptoethanol, see Thioglycol												
2-Mercaptopropionic acid, see Thiolactic acid												
5-Mercaptotetrazol-1-acetic acid	0448	1.4C		Explosive 1.4				E0	FORBIDDEN		114 b)	75 kg
Mercuric arsenate	1623	6.1		Toxic			II	E4	669 Y644	25 kg 1 kg	676	100 kg
Mercuric chloride	1624	6.1		Toxic			II	E4	669 Y644	25 kg 1 kg	676	100 kg
Mercuric nitrate	1625	6.1		Toxic	US 4		II	E4	669 Y644	25 kg 1 kg	676	100 kg
Mercuric potassium cyanide	1626	6.1		Toxic			I	E5	666	5 kg	673	50 kg

Name	UN No.	Class or division	Subsidiary risk	Labels	State variations	Special provisions	UN packing group	Excepted quantity	Passenger and cargo aircraft		Cargo aircraft only	
									Packing instruction	Max. net quantity per package	Packing instruction	Max. net quantity per package
1	2	3	4	5	6	7	8	9	10	11	12	13
Mercuric sulphate, see Mercury sulphate												
Mercuriol, see Mercury nucleate												
Mercurous azide		FORBIDDEN										
Mercurous bisulphate, see Mercury sulphate												
+ Mercurous chloride, see Mercury compound, solid, n.o.s. (UN No. 2025)												
Mercurous nitrate	1627	6.1		Toxic	US 4		II	E4	669 Y644	25 kg 1 kg	676	100 kg
Mercurous sulphate, see Mercury sulphate												
Mercury	2809	8	6.1	Corrosive & Toxic	US 4		III	E0	868	35 kg	868	35 kg
Mercury acetate	1629	6.1		Toxic			II	E4	669 Y644	25 kg 1 kg	676	100 kg
Mercury acetylide		FORBIDDEN										
Mercury ammonium chloride	1630	6.1		Toxic			II	E4	669 Y644	25 kg 1 kg	676	100 kg
Mercury based pesticide, liquid, flammable, toxic* , flash point less than 23°C	2778	3	6.1	Liquid flammable & Toxic		A4	I II	E0 E2	FORBIDDEN 352 Y341	1 L 1 L	361 364	30 L 60 L
Mercury based pesticide, liquid, toxic*	3012	6.1		Toxic		A3 A4	I II III	E5 E4 E1	652 654 Y641 655 Y642	1 L 5 L 1 L 60 L 2 L	658 662 663	30 L 60 L 220 L
Mercury based pesticide, liquid, toxic, flammable* , flash point not less than 23°C	3011	6.1	3	Toxic & Liquid flammable		A3 A4	I II III	E5 E4 E1	652 654 Y641 655 Y642	1 L 5 L 1 L 60 L 2 L	658 662 663	30 L 60 L 220 L
Mercury based pesticide, solid, toxic*	2777	6.1		Toxic		A3 A5	I II III	E5 E4 E1	666 669 Y644 670 Y645	5 kg 25 kg 1 kg 100 kg 10 kg	673 676 677	50 kg 100 kg 200 kg

Name	UN No.	Class or division	Subsidiary risk	Labels	State variations	Special provisions	UN packing group	Excepted quantity	Passenger and cargo aircraft		Cargo aircraft only	
									Packing instruction	Max. net quantity per package	Packing instruction	Max. net quantity per package
1	2	3	4	5	6	7	8	9	10	11	12	13
Mercury benzoate	1631	6.1		Toxic			II	E4	669 Y644	25 kg 1 kg	676	100 kg
Mercury bichloride, see Mercuric chloride												
Mercury bromides	1634	6.1		Toxic			II	E4	669 Y644	25 kg 1 kg	676	100 kg
Mercury compound, liquid, n.o.s.*	2024	6.1		Toxic		A3 A4 A6 A18	I II	E5 E4	652 654 Y641 655 Y642	1 L 5 L 1 L 60 L 2 L	658 661 663	30 L 60 L 220 L
Mercury compound, solid, n.o.s.*	2025	6.1		Toxic		A3 A5 A6 A18	I II	E5 E4	666 669 Y644 670 Y645	5 kg 25 kg 1 kg 100 kg 10 kg	673 676 677	50 kg 100 kg 200 kg
‡ Mercury contained in manufactured articles	3506	8	6.1	Corrosive & Toxic		A48 A69 A191		E0	869	No limit	869	No limit
Mercury cyanide	1636	6.1		Toxic	US 4		II	E4	669 Y644	25 kg 1 kg	676	100 kg
Mercury fulminate, wetted with not less than 20% water, or mixture of alcohol and water, by mass	0135	1.1A							FORBIDDEN		FORBIDDEN	
Mercury gluconate	1637	6.1		Toxic			II	E4	669 Y644	25 kg 1 kg	676	100 kg
Mercury iodide	1638	6.1		Toxic			II	E4	669 Y644	25 kg 1 kg	676	100 kg
Mercury iodide aquabasic ammonobasic (Iodide of Millon's base)	FORBIDDEN											
Mercury nitride	FORBIDDEN											
Mercury nucleate	1639	6.1		Toxic			II	E4	669 Y644	25 kg 1 kg	676	100 kg
Mercury oleate	1640	6.1		Toxic			II	E4	669 Y644	25 kg 1 kg	676	100 kg
Mercury oxide	1641	6.1		Toxic			II	E4	669 Y644	25 kg 1 kg	676	100 kg
Mercury oxycyanide, desensitized	1642	6.1		Toxic			II	E4	669 Y644	25 kg 1 kg	676	100 kg
Mercury potassium iodide	1643	6.1		Toxic			II	E4	669 Y644	25 kg 1 kg	676	100 kg

Name	UN No.	Class or division	Subsidiary risk	Labels	State variations	Special provisions	UN packing group	Excepted quantity	Passenger and cargo aircraft		Cargo aircraft only	
									Packing instruction	Max. net quantity per package	Packing instruction	Max. net quantity per package
1	2	3	4	5	6	7	8	9	10	11	12	13
Mercury salicylate	1644	6.1		Toxic			II	E4	669 Y644	25 kg 1 kg	676	100 kg
Mercury sulphate	1645	6.1		Toxic	US 4		II	E4	669 Y644	25 kg 1 kg	676	100 kg
Mercury thiocyanate	1646	6.1		Toxic	US 4		II	E4	669 Y644	25 kg 1 kg	676	100 kg
Mercury vapour tubes, see Mercury contained in manufactured articles (UN No. 3506)												
Mesitylene, see 1,3,5-Trimethylbenzene												
Mesityl oxide	1229	3		Liquid flammable			III	E1	355 Y344	60 L 10 L	366	220 L
Metal carbonyls, liquid, n.o.s.*	3281	6.1		Toxic		A3 A4 A137	I II III	E5 E4 E1	652 654 Y641 655 Y642	1 L 5 L 1 L 60 L 2 L	658 662 663	30 L 60 L 220 L
Metal carbonyls, solid, n.o.s.*	3466	6.1		Toxic		A3 A5	I II III	E5 E4 E1	666 669 Y644 670 Y645	5 kg 25 kg 1 kg 100 kg 10 kg	673 676 677	50 kg 100 kg 200 kg
Metal catalyst, dry*	2881	4.2		Spontaneous combustion		A3 A36	II III	E0 E1	FORBIDDEN FORBIDDEN 473	FORBIDDEN FORBIDDEN 25 kg	FORBIDDEN 473 473	FORBIDDEN 50 kg 100 kg
Metal catalyst, wetted* with a visible excess of liquid	1378	4.2		Spontaneous combustion	AU 1 CA 7 IR 3 NL 1 US 3	A1	II	E0	FORBIDDEN	FORBIDDEN	473	50 kg
Metaldehyde	1332	4.1		Solid flammable			III	E1	446 Y443	25 kg 10 kg	449	100 kg
Metal hydrides, flammable, n.o.s.*	3182	4.1		Solid flammable		A3	II III	E2 E1	445 Y441 446 Y443	15 kg 5 kg 25 kg 10 kg	448 449	50 kg 100 kg
Metal hydrides, water-reactive, n.o.s.*	1409	4.3		Danger if wet			I II	E0 E2	FORBIDDEN 484 Y475	FORBIDDEN 15 kg 5 kg	487 490	15 kg 50 kg

Name	UN No.	Class or division	Subsidiary risk	Labels	State variations	Special provisions	UN packing group	Excepted quantity	Passenger and cargo aircraft		Cargo aircraft only					
									Packing instruction	Max. net quantity per package	Packing instruction	Max. net quantity per package				
1	2	3	4	5	6	7	8	9	10	11	12	13				
Metallic substance, water-reactive, n.o.s.*	3208	4.3		Danger if wet		A3	I	E0	FORBIDDEN	487	15 kg	489	50 kg			
									483					15 kg		
									Y475					5 kg		
									485					25 kg		
Metallic substance, water-reactive, self-heating, n.o.s.*	3209	4.3	4.2	Danger if wet & Spontaneous combustion		A3	I	E0	FORBIDDEN	487	15 kg	489	50 kg			
									FORBIDDEN					491	100 kg	
									485							25 kg
Metal powder, flammable, n.o.s.	3089	4.1		Solid flammable		A3	II	E2	445	15 kg	448	50 kg				
									Y441	5 kg						
									446	25 kg						
Metal powder, self-heating, n.o.s.*	3189	4.2		Spontaneous combustion		A3	II	E2	467	15 kg	470	50 kg				
									469	25 kg						
Metal salts of organic compounds, flammable, n.o.s.*	3181	4.1		Solid flammable		A3	II	E2	445	15 kg	448	50 kg				
									Y441	5 kg						
									446	25 kg						
Methacrylaldehyde, stabilized	2396	3	6.1	Liquid flammable & Toxic			II	E2	352	1 L	364	60 L				
									Y341	1 L						
Methacrylic acid, stabilized	2531	8		Corrosive			II	E2	851	1 L	855	30 L				
Methacrylonitrile, stabilized	3079	6.1	3						FORBIDDEN		FORBIDDEN					
Methallyl alcohol	2614	3		Liquid flammable			III	E1	355	60 L	366	220 L				
Methanal, see Formaldehyde solution																
Methane and hydrogen, mixture, compressed, see Hydrogen and methane, mixture, compressed																
Methane, compressed	1971	2.1		Gas flammable	AU 1 CA 7 IR 3 NL 1 US 3	A1		E0	FORBIDDEN		200	150 kg				
Methane, refrigerated liquid with high methane content	1972	2.1							FORBIDDEN		FORBIDDEN					
Methanesulphonyl chloride	3246	6.1	8						FORBIDDEN		FORBIDDEN					
Methanol	1230	3	6.1	Liquid flammable		A104 A113	II	E2	352	1 L	364	60 L				
									Y341	1 L						

Name	UN No.	Class or division	Subsidiary risk	Labels	State variations	Special provisions	UN packing group	Excepted quantity	Passenger and cargo aircraft		Cargo aircraft only	
									Packing instruction	Max. net quantity per package	Packing instruction	Max. net quantity per package
1	2	3	4	5	6	7	8	9	10	11	12	13
Methazoic acid	FORBIDDEN											
2-Methoxyethyl acetate, see Ethylene glycol monomethyl ether acetate												
Methoxymethyl isocyanate	2605	6.1	3						FORBIDDEN		FORBIDDEN	
4-Methoxy-4-methylpentan-2-one	2293	3		Liquid flammable			III	E1	355 Y344	60 L 10 L	366	220 L
1-Methoxy-2-nitrobenzene, see Nitroanisoles, liquid (UN No. 2730) or Nitroanisoles, solid (UN No. 3458)												
1-Methoxy-3-nitrobenzene, see Nitroanisoles, liquid (UN No. 2730) or Nitroanisoles, solid (UN No. 3458)												
1-Methoxy-4-nitrobenzene, see Nitroanisoles, liquid (UN No. 2730) or Nitroanisoles, solid (UN No. 3458)												
1-Methoxy-2-propanol	3092	3		Liquid flammable			III	E1	355 Y344	60 L 10 L	366	220 L
Methyl acetate	1231	3		Liquid flammable			II	E2	353 Y341	5 L 1 L	364	60 L
Methylacetylene and propadiene mixture, stabilized †	1060	2.1		Gas flammable	AU 1 CA 7 IR 3 NL 1 US 3	A1		E0	FORBIDDEN		200	150 kg
beta-Methyl acrolein, see Crotonaldehyde or Crotonaldehyde, stabilized (UN No. 1143)												
Methyl acrylate, stabilized	1919	3		Liquid flammable			II	E2	353 Y341	5 L 1 L	364	60 L
Methylal	1234	3		Liquid flammable			II	E2	353 Y341	5 L 1 L	364	60 L
Methyl alcohol, see Methanol												
Methyl allyl alcohol, see Methylallyl alcohol												
Methylallyl chloride	2554	3		Liquid flammable			II	E2	353 Y341	5 L 1 L	364	60 L

Name	UN No.	Class or division	Subsidiary risk	Labels	State variations	Special provisions	UN packing group	Excepted quantity	Passenger and cargo aircraft		Cargo aircraft only	
									Packing instruction	Max. net quantity per package	Packing instruction	Max. net quantity per package
1	2	3	4	5	6	7	8	9	10	11	12	13
Methylamine, anhydrous	1061	2.1		Gas flammable	AU 1 CA 7 IR 3 NL 1 US 3 US 4	A1		E0	FORBIDDEN		200	150 kg
Methylamine, aqueous solution	1235	3	8	Liquid flammable & Corrosive			II	E2	352 Y340	1 L 0.5 L	363	5 L
Methylamine dinitramine and dry salts thereof	FORBIDDEN											
Methylamine nitroform	FORBIDDEN											
Methylamine perchlorate (dry)	FORBIDDEN											
Methylamyl acetate	1233	3		Liquid flammable			III	E1	355 Y344	60 L 10 L	366	220 L
Methyl amyl alcohol, see Methyl isobutyl carbinol												
Methyl amyl ketone, see n-Amyl methyl ketone (UN No. 1110)												
N-Methylaniline	2294	6.1		Toxic			III	E1	655 Y642	60 L 2 L	663	220 L
Methylated spirit, see Alcohols, n.o.s. or Alcohols, flammable, toxic, n.o.s.												
alpha-Methylbenzyl alcohol, liquid	2937	6.1		Toxic			III	E1	655 Y642	60 L 2 L	663	220 L
alpha-Methylbenzyl alcohol, solid	3438	6.1		Toxic			III	E1	670 Y645	100 kg 10 kg	677	200 kg
Methyl bromide with not more than 2% chloropicrin	1062	2.3			AU 1 CA 7 IR 3 NL 1 US 3	A2			FORBIDDEN		FORBIDDEN	
Methyl bromide and chloropicrin mixture, see Chloropicrin and methyl bromide mixture												
Methyl bromide and ethylene dibromide mixture, liquid	1647	6.1			AU 1 CA 7 NL 1 US 3				FORBIDDEN		FORBIDDEN	

Name	UN No.	Class or division	Subsidiary risk	Labels	State variations	Special provisions	UN packing group	Excepted quantity	Passenger and cargo aircraft		Cargo aircraft only	
									Packing instruction	Max. net quantity per package	Packing instruction	Max. net quantity per package
1	2	3	4	5	6	7	8	9	10	11	12	13
Methyl bromoacetate	2643	6.1		Toxic			II	E4	654 Y641	5 L 1 L	662	60 L
2-Methylbutanal	3371	3		Liquid flammable			II	E2	353 Y341	5 L 1 L	364	60 L
3-Methylbutan-2-one	2397	3		Liquid flammable			II	E2	353 Y341	5 L 1 L	364	60 L
2-Methyl-1-butene	2459	3		Liquid flammable			I	E3	351	1 L	361	30 L
2-Methyl-2-butene	2460	3		Liquid flammable			II	E2	353 Y341	5 L 1 L	364	60 L
3-Methyl-1-butene	2561	3		Liquid flammable			I	E3	351	1 L	361	30 L
N-Methylbutylamine	2945	3	8	Liquid flammable & Corrosive			II	E2	352 Y340	1 L 0.5 L	363	5 L
Methyl tert-butyl ether	2398	3		Liquid flammable			II	E2	353 Y341	5 L 1 L	364	60 L
Methyl butyrate	1237	3		Liquid flammable			II	E2	353 Y341	5 L 1 L	364	60 L
Methyl chloride	1063	2.1		Gas flammable	AU 1 CA 7 IR 3 NL 1 US 3	A1		E0	FORBIDDEN		200	100 kg
Methyl chloride and chloropicrin mixture, see Chloropicrin and methyl chloride mixture												
Methyl chloride and methylene chloride mixture	1912	2.1		Gas flammable	AU 1 CA 7 IR 3 NL 1 US 3	A1 A52		E0	FORBIDDEN		200	150 kg
Methyl chloroacetate	2295	6.1	3						FORBIDDEN		FORBIDDEN	
Methyl chlorocarbonate, see Methyl chloroformate												
Methyl chloroform, see 1,1,1-Trichloroethane												
Methyl chloroformate	1238	6.1	3 8						FORBIDDEN		FORBIDDEN	
Methyl chloromethyl ether	1239	6.1	3						FORBIDDEN		FORBIDDEN	
Methyl 2-chloropropionate	2933	3		Liquid flammable			III	E1	355 Y344	60 L 10 L	366	220 L
Methyl-alpha-chloropropionate, see Methyl 2-chloropropionate												

Name	UN No.	Class or division	Subsidiary risk	Labels	State variations	Special provisions	UN packing group	Excepted quantity	Passenger and cargo aircraft		Cargo aircraft only	
									Packing instruction	Max. net quantity per package	Packing instruction	Max. net quantity per package
1	2	3	4	5	6	7	8	9	10	11	12	13
Methylchlorosilane	2534	2.3	2.1 8		AU 1 CA 7 IR 3 NL 1 US 3	A2			FORBIDDEN		FORBIDDEN	
Methyl cyanide, see Acetonitrile												
Methylcyclohexane	2296	3		Liquid flammable			II	E2	353 Y341	5 L 1 L	364	60 L
Methylcyclohexanols , flammable	2617	3		Liquid flammable			III	E1	355 Y344	60 L 10 L	366	220 L
Methylcyclohexanone	2297	3		Liquid flammable			III	E1	355 Y344	60 L 10 L	366	220 L
Methylcyclopentane	2298	3		Liquid flammable			II	E2	353 Y341	5 L 1 L	364	60 L
Methyl dichloroacetate	2299	6.1		Toxic			III	E1	655 Y642	60 L 2 L	663	220 L
Methyldichlorosilane	1242	4.3	3 8	Danger if wet & Liquid flammable & Corrosive			I	E0	FORBIDDEN		480	1 L
Methylene bromide, see Dibromomethane												
Methylene chloride, see Dichloromethane												
Methylene chloride and methyl chloride mixture, see Methyl chloride and methylene chloride mixture												
Methylene cyanide, see Malononitrile												
2,2'-Methylene-di- (3,4,6-trichlorophenol), see Hexachlorophene												
p,p'-Methylene dianiline, see 4,4'-Diaminodiphenylmethane												
Methylene dibromide, see Dibromomethane												
Methylene glycol dinitrate		FORBIDDEN										

Name	UN No.	Class or division	Subsidiary risk	Labels	State variations	Special provisions	UN packing group	Excepted quantity	Passenger and cargo aircraft		Cargo aircraft only	
									Packing instruction	Max. net quantity per package	Packing instruction	Max. net quantity per package
1	2	3	4	5	6	7	8	9	10	11	12	13
Methyl ethyl ether, see Ethyl methyl ether												
Methyl ethyl ketone	1193	3		Liquid flammable			II	E2	353 Y341	5 L 1 L	364	60 L
Methyl ethyl ketone peroxide(s), 48% or more if available oxygen above 10% and not more than 10.7%, with or without water	FORBIDDEN											
Methyl ethyl ketone peroxide(s), not more than 52% when with 48% or more diluent type A	FORBIDDEN											
2-Methyl-5-ethylpyridine	2300	6.1		Toxic			III	E1	655 Y642	60 L 2 L	663	220 L
Methyl fluoride	2454	2.1		Gas flammable	AU 1 CA 7 IR 3 NL 1 US 3	A1		E0	FORBIDDEN		200	150 kg
Methyl formate	1243	3		Liquid flammable			I	E3	351	1 L	361	30 L
2-Methylfuran	2301	3		Liquid flammable			II	E2	353 Y341	5 L 1 L	364	60 L
a-Methylglucoside tetranitrate	FORBIDDEN											
a-Methylglycerol trinitrate	FORBIDDEN											
Methyl glycol, see Ethylene glycol monomethyl ether												
Methyl glycol acetate, see Ethylene glycol monomethyl ether acetate												
2-Methyl-2-heptanethiol	3023	6.1	3						FORBIDDEN		FORBIDDEN	
5-Methylhexan-2-one	2302	3		Liquid flammable			III	E1	355 Y344	60 L 10 L	366	220 L
Methylhydrazine	1244	6.1	3 8						FORBIDDEN		FORBIDDEN	
Methyl iodide	2644	6.1			US 4				FORBIDDEN		FORBIDDEN	
Methyl isobutyl carbinol	2053	3		Liquid flammable			III	E1	355 Y344	60 L 10 L	366	220 L
Methyl isobutyl ketone	1245	3		Liquid flammable			II	E2	353 Y341	5 L 1 L	364	60 L
Methyl isocyanate	2480	6.1	3						FORBIDDEN		FORBIDDEN	

Name	UN No.	Class or division	Subsidiary risk	Labels	State variations	Special provisions	UN packing group	Excepted quantity	Passenger and cargo aircraft		Cargo aircraft only	
									Packing instruction	Max. net quantity per package	Packing instruction	Max. net quantity per package
1	2	3	4	5	6	7	8	9	10	11	12	13
Methyl isopropenyl ketone, stabilized	1246	3		Liquid flammable			II	E2	353 Y341	5 L 1 L	364	60 L
Methyl isothiocyanate	2477	6.1	3						FORBIDDEN		FORBIDDEN	
Methyl isovalerate	2400	3		Liquid flammable			II	E2	353 Y341	5 L 1 L	364	60 L
Methyl magnesium bromide in ethyl ether	1928	4.3	3	Danger if wet & Liquid flammable			I	E0	FORBIDDEN		480	1 L
Methyl mercaptan	1064	2.3	2.1		AU 1 CA 7 IR 3 NL 1 US 3	A2			FORBIDDEN		FORBIDDEN	
Methyl mercaptopropionaldehyde, see 4-Thiapentanal (UN No. 2785)												
Methyl methacrylate monomer, stabilized	1247	3		Liquid flammable			II	E2	353 Y341	5 L 1 L	364	60 L
4-Methylmorpholine	2535	3	8	Liquid flammable & Corrosive			II	E2	352 Y340	1 L 0.5 L	363	5 L
N-Methylmorpholine	2535	3	8	Liquid flammable & Corrosive			II	E2	352 Y340	1 L 0.5 L	363	5 L
Methyl nitramine (dry), metal salts of									FORBIDDEN			
Methyl nitrate									FORBIDDEN			
Methyl nitrite									FORBIDDEN			
Methyl orthosilicate	2606	6.1	3						FORBIDDEN		FORBIDDEN	
Methylpentadiene	2461	3		Liquid flammable			II	E2	353 Y341	5 L 1 L	364	60 L
Methylpentanes, see Hexanes												
2-Methylpentan-2-ol	2560	3		Liquid flammable			III	E1	355 Y344	60 L 10 L	366	220 L
4-Methylpentan-2-ol, see Methyl isobutyl carbinol												
3-Methyl-2-penten-4-ynol, see 1-Pentol												

Name	UN No.	Class or division	Subsidiary risk	Labels	State variations	Special provisions	UN packing group	Excepted quantity	Passenger and cargo aircraft		Cargo aircraft only	
									Packing instruction	Max. net quantity per package	Packing instruction	Max. net quantity per package
1	2	3	4	5	6	7	8	9	10	11	12	13
Methylphenyldichlorosilane	2437	8		Corrosive	AU 1 CA 7 IR 3 NL 1 US 3	A1	II	E0	FORBIDDEN		876	30 L
2-Methyl-2-phenylpropane, see Butylbenzenes												
Methyl picric acid (heavy metal salts of)	FORBIDDEN											
1-Methylpiperidine	2399	3	8	Liquid flammable & Corrosive			II	E2	352 Y340	1 L 0.5 L	363	5 L
Methyl propionate	1248	3		Liquid flammable			II	E2	353 Y341	5 L 1 L	364	60 L
Methylpropylbenzene, see Cymenes												
Methyl propyl ether	2612	3		Liquid flammable			II	E2	353 Y341	5 L 1 L	364	60 L
Methyl propyl ketone	1249	3		Liquid flammable			II	E2	353 Y341	5 L 1 L	364	60 L
Methyl pyridines, see Picolines												
alpha-Methylstyrene, see Isopropenylbenzene												
Methylstyrene, stabilized, see Vinytoluenes, stabilized (UN No. 2618)												
Methyl sulphate, see Dimethyl sulphate												
Methyl sulphide, see Dimethyl sulphide												
Methyltetrahydrofuran	2536	3		Liquid flammable			II	E2	353 Y341	5 L 1 L	364	60 L
Methyl trichloroacetate	2533	6.1		Toxic			III	E1	655 Y642	60 L 2 L	663	220 L
Methyltrichlorosilane	1250	3	8	Liquid flammable & Corrosive	AU 1 CA 7 IR 3 NL 1 US 3		II	E0	FORBIDDEN		377	5 L
Methyl trimethylol methane trinitrate	FORBIDDEN											

Name	UN No.	Class or division	Subsidiary risk	Labels	State variations	Special provisions	UN packing group	Excepted quantity	Passenger and cargo aircraft		Cargo aircraft only	
									Packing instruction	Max. net quantity per package	Packing instruction	Max. net quantity per package
1	2	3	4	5	6	7	8	9	10	11	12	13
alpha-Methylvaleraldehyde	2367	3		Liquid flammable			II	E2	353 Y341	5 L 1 L	364	60 L
Methyl vinyl benzene, stabilized, see Vinytoluenes, stabilized (UN No. 2618)												
Methyl vinyl ketone, stabilized	1251	6.1	3 8						FORBIDDEN		FORBIDDEN	
MIBC, see Methyl isobutyl carbinol												
Mine rescue equipment containing carbon dioxide, see Carbon dioxide												
Mines with bursting charge †	0136	1.1F							FORBIDDEN		FORBIDDEN	
Mines with bursting charge †	0137	1.1D							FORBIDDEN		FORBIDDEN	
Mines with bursting charge †	0138	1.2D							FORBIDDEN		FORBIDDEN	
Mines with bursting charge †	0294	1.2F							FORBIDDEN		FORBIDDEN	
Mirbane oil, see Nitrobenzene												
Missiles, guided, see Rockets , (UN No. 0398) liquid fuelled , etc. or Rockets , etc.												
Mobility aids, see Battery-powered equipment or Battery-powered vehicle												
Molybdenum pentachloride	2508	8		Corrosive			III	E1	860 Y845	25 kg 5 kg	864	100 kg
Monochloroacetic acid, see Chloroacetic acid , etc.												
Monochlorobenzene, see Chlorobenzene												
Monochlorodifluoromethane, see Chlorodifluoromethane												
Monochlorodifluoromethane and monochloropentafluoroethane mixture, see Chlorodifluoromethane and chloropentafluoroethane mixture , etc.												

Name	UN No.	Class or division	Subsidiary risk	Labels	State variations	Special provisions	UN packing group	Excepted quantity	Passenger and cargo aircraft		Cargo aircraft only	
									Packing instruction	Max. net quantity per package	Packing instruction	Max. net quantity per package
1	2	3	4	5	6	7	8	9	10	11	12	13
Monochlorodifluoromono-bromomethane, see Chlorodifluorobromomethane												
Monoethylamine, see Ethylamine												
Monopropylamine, see Propylamine												
Morpholine	2054	8	3	Corrosive & Liquid flammable			I	E0	850	0.5 L	854	2.5 L
Motorcycles, see Vehicle (flammable gas powered) or Vehicle (flammable liquid powered)												
Motor fuel anti-knock mixture	1649	6.1		Toxic	AU 1 CA 7 IR 3 NL 1 US 3	A1	I	E0	FORBIDDEN		658	30 L
Motor fuel anti-knock mixture, flammable	3483	6.1	3		AU 1 CA 7 IR 3 NL 1 US 3	A2			FORBIDDEN		FORBIDDEN	
Motor spirit	1203	3		Liquid flammable		A100	II	E2	353 Y341	5 L 1 L	364	60 L
Muriatic acid, see Hydrochloric acid												
Musk xylene	2956	4.1							FORBIDDEN		FORBIDDEN	
‡ Mysorite, see Asbestos, amphibole (UN No. 2212)												
N												
Naphtha, see Petroleum distillates, n.o.s.												
Naphthalene, crude	1334	4.1		Solid flammable	US 4		III	E1	446 Y443	25 kg 10 kg	449	100 kg
Naphthalene diozonide	FORBIDDEN											
Naphthalene, molten	2304	4.1							FORBIDDEN		FORBIDDEN	
Naphthalene, refined	1334	4.1		Solid flammable	US 4		III	E1	446 Y443	25 kg 10 kg	449	100 kg

Name	UN No.	Class or division	Subsidiary risk	Labels	State variations	Special provisions	UN packing group	Excepted quantity	Passenger and cargo aircraft		Cargo aircraft only	
									Packing instruction	Max. net quantity per package	Packing instruction	Max. net quantity per package
1	2	3	4	5	6	7	8	9	10	11	12	13
Naphtha, petroleum, see Petroleum distillates, n.o.s.												
Naphtha, solvent, see Petroleum products, n.o.s.												
alpha-Naphthylamine	2077	6.1		Toxic	US 4		III	E1	670 Y645	100 kg 10 kg	677	200 kg
Naphthyl amineperchlorate	FORBIDDEN											
beta-Naphthylamine, solid	1650	6.1		Toxic	US 4		II	E4	669 Y644	25 kg 1 kg	676	100 kg
beta-Naphthylamine solution	3411	6.1		Toxic		A3	II	E4	654 Y641	5 L 1 L	662	60 L
							III	E1	655 Y642	60 L 2 L	663	220 L
Naphthylthiourea	1651	6.1		Toxic	US 4	A6	II	E4	669 Y644	25 kg 1 kg	676	100 kg
1-Naphthylthiourea, see Naphthylthiourea												
Naphthylurea	1652	6.1		Toxic			II	E4	669 Y644	25 kg 1 kg	676	100 kg
Natural gas, compressed with high methane content	1971	2.1		Gas flammable	AU 1 CA 7 IR 3 NL 1 US 3	A1		E0	FORBIDDEN		200	150 kg
Natural gasoline, see Gasoline or Motor spirit or Petrol												
Natural gas, refrigerated liquid with high methane content	1972	2.1							FORBIDDEN		FORBIDDEN	
Neohexane, see Hexanes												
Neon, compressed	1065	2.2		Gas non-flammable		A69		E1	200	75 kg	200	150 kg
Neon, refrigerated liquid	1913	2.2		Gas non-flammable				E1	202	50 kg	202	500 kg
Neothyl, see Methyl propyl ether												
Nickel carbonyl	1259	6.1	3						FORBIDDEN		FORBIDDEN	
Nickel cyanide	1653	6.1		Toxic	US 4		II	E4	669 Y644	25 kg 1 kg	676	100 kg
Nickel (II) cyanide, see Nickel cyanide												

Name	UN No.	Class or division	Subsidiary risk	Labels	State variations	Special provisions	UN packing group	Excepted quantity	Passenger and cargo aircraft		Cargo aircraft only	
									Packing instruction	Max. net quantity per package	Packing instruction	Max. net quantity per package
1	2	3	4	5	6	7	8	9	10	11	12	13
Nickel nitrate	2725	5.1		Oxidizer	US 4		III	E1	559 Y546	25 kg 10 kg	563	100 kg
Nickel (II) nitrate, see Nickel nitrate												
Nickel nitrite	2726	5.1		Oxidizer			III	E1	559 Y546	25 kg 10 kg	563	100 kg
Nickel (II) nitrite, see Nickel nitrite												
Nickelous nitrate, see Nickel nitrate												
Nickelous nitrite, see Nickel nitrite												
Nickel picrate	FORBIDDEN											
Nickel tetracarbonyl, see Nickel carbonyl												
Nicotine	1654	6.1		Toxic			II	E4	654 Y641	5 L 1 L	662	60 L
Nicotine compound, liquid, n.o.s.*	3144	6.1		Toxic	US 4	A3 A4 A6	I II	E5 E4	652 654 Y641	1 L 5 L 1 L	658 662	30 L 60 L
							III	E1	655 Y642	60 L 2 L	663	220 L
Nicotine compound, solid, n.o.s.*	1655	6.1		Toxic	US 4	A3 A5 A6	I II	E5 E4	666 669 Y644	5 kg 25 kg 1 kg	673 676	50 kg 100 kg
							III	E1	670 Y645	100 kg 10 kg	677	200 kg
Nicotine hydrochloride, liquid	1656	6.1		Toxic	US 4	A3 A6	II	E4	654 Y641	5 L 1 L	662	60 L
							III	E1	655 Y642	60 L 2 L	663	220 L
Nicotine hydrochloride, solid	3444	6.1		Toxic		A6	II	E4	669 Y644	25 kg 1 kg	676	100 kg
Nicotine hydrochloride solution	1656	6.1		Toxic	US 4	A3 A6	II	E4	654 Y641	5 L 1 L	662	60 L
							III	E1	655 Y642	60 L 2 L	663	220 L
Nicotine preparation, liquid, n.o.s.*	3144	6.1		Toxic	US 4	A3 A4 A6	I II	E5 E4	652 654 Y641	1 L 5 L 1 L	658 662	30 L 60 L
							III	E1	655 Y642	60 L 2 L	663	220 L

Name	UN No.	Class or division	Subsidiary risk	Labels	State variations	Special provisions	UN packing group	Excepted quantity	Passenger and cargo aircraft		Cargo aircraft only	
									Packing instruction	Max. net quantity per package	Packing instruction	Max. net quantity per package
1	2	3	4	5	6	7	8	9	10	11	12	13
Nicotine preparation, solid, n.o.s.*	1655	6.1		Toxic	US 4	A3 A5 A6	I II III	E5 E4 E1	666	5 kg	673	50 kg
									669	25 kg	676	100 kg
									Y644	1 kg		
									670	100 kg	677	200 kg
									Y645	10 kg		
Nicotine salicylate	1657	6.1		Toxic	US 4		II	E4	669 Y644	25 kg 1 kg	676	100 kg
Nicotine sulphate, solid	3445	6.1		Toxic	US 4	A3	II	E4	669 Y644	25 kg 1 kg	676	100 kg
Nicotine sulphate solution	1658	6.1		Toxic	US 4	A3	II III	E4 E1	654	5 L	662	60 L
									Y641	1 L		
									655	60 L	663	220 L
									Y642	2 L		
Nicotine tartrate	1659	6.1		Toxic	US 4		II	E4	669 Y644	25 kg 1 kg	676	100 kg
Nitrates, inorganic, n.o.s.	1477	5.1		Oxidizer		A3	II III	E2 E1	558	5 kg	562	25 kg
									Y544	2.5 kg		
									559	25 kg	563	100 kg
									Y546	10 kg		
Nitrates, inorganic, aqueous solution, n.o.s.	3218	5.1		Oxidizer		A3 A65	II III	E2 E1	550	1 L	554	5 L
									Y540	0.5 L		
									551	2.5 L	555	30 L
									Y541	1 L		
Nitrates of diazonium compounds	FORBIDDEN											
Nitrating acid mixture with more than 50% nitric acid †	1796	8	5.1	Corrosive & Oxidizer			I	E0	FORBIDDEN		854	2.5 L
Nitrating acid mixture with not more than 50% nitric acid †	1796	8		Corrosive	AU 1 CA 7 IR 3 NL 1 US 3	A1	II	E0	FORBIDDEN		855	30 L
Nitrating acid mixture, spent with more than 50% nitric acid †	1826	8	5.1	Corrosive & Oxidizer		A34	I	E0	FORBIDDEN		854	2.5 L
Nitrating acid mixture, spent with not more than 50% nitric acid †	1826	8		Corrosive	AU 1 CA 7 IR 3 NL 1 US 3	A1 A34	II	E0	FORBIDDEN		855	30 L
Nitric acid , other than red fuming, with at least 65% but not more than 70% nitric acid	2031	8	5.1	Corrosive & Oxidizer	AU 1 CA 7 IR 3 NL 1 US 3	A1	II	E0	FORBIDDEN		855	30 L

Name	UN No.	Class or division	Subsidiary risk	Labels	State variations	Special provisions	UN packing group	Excepted quantity	Passenger and cargo aircraft		Cargo aircraft only	
									Packing instruction	Max. net quantity per package	Packing instruction	Max. net quantity per package
1	2	3	4	5	6	7	8	9	10	11	12	13
Nitric acid, other than red fuming, with more than 20% and less than 65% nitric acid	2031	8		Corrosive			II	E0	FORBIDDEN		855	30 L
Nitric acid, other than red fuming, with more than 70% nitric acid	2031	8	5.1	Corrosive & Oxidizer			I	E0	FORBIDDEN		854	2.5 L
Nitric acid, other than red fuming, with not more than 20% nitric acid	2031	8		Corrosive			II	E2	851 Y840	1 L 0.5 L	855	30 L
Nitric acid, red fuming	2032	8	5.1 6.1						FORBIDDEN		FORBIDDEN	
Nitric oxide and dinitrogen tetroxide mixture	1975	2.3	5.1 8		AU 1 CA 7 IR 3 NL 1 US 3	A2			FORBIDDEN		FORBIDDEN	
Nitric oxide and nitrogen dioxide mixture	1975	2.3	5.1 8		AU 1 CA 7 IR 3 NL 1 US 3	A2			FORBIDDEN		FORBIDDEN	
Nitric oxide, compressed	1660	2.3	5.1 8		AU 1 CA 7 IR 3 NL 1 US 3	A2			FORBIDDEN		FORBIDDEN	
Nitriles, flammable, toxic, n.o.s.*	3273	3	6.1	Liquid flammable & Toxic			I	E0	FORBIDDEN		361	30 L
								E2	352 Y341	1 L 1 L	364	60 L
Nitriles, liquid, toxic, n.o.s.*	3276	6.1		Toxic			I	E5	652	1 L	658	30 L
								II	654	5 L	662	60 L
								A137	Y641	1 L		
								III	655 Y642	60 L 2 L	663	220 L
Nitriles, solid, toxic, n.o.s.*	3439	6.1		Toxic			I	E5	666	5 kg	673	50 kg
								II	669	25 kg	676	100 kg
									Y644	1 kg		
								III	670 Y645	100 kg 10 kg	677	200 kg
Nitriles, toxic, flammable, n.o.s.*	3275	6.1	3	Toxic & Liquid flammable			I	E5	652	1 L	658	30 L
								II	654	5 L	662	60 L
								A137	Y641	1 L		
Nitrites, inorganic, n.o.s.*	2627	5.1		Oxidizer		A33	II	E2	558 Y544	5 kg 2.5 kg	562	25 kg

Name	UN No.	Class or division	Subsidiary risk	Labels	State variations	Special provisions	UN packing group	Excepted quantity	Passenger and cargo aircraft		Cargo aircraft only	
									Packing instruction	Max. net quantity per package	Packing instruction	Max. net quantity per package
Nitrites, inorganic, aqueous solution, n.o.s.*	3219	5.1		Oxidizer		A3 A33	II	E2	550 Y540 551 Y541	1 L 0.5 L 2.5 L 1 L	554 555	5 L 30 L
N-Nitroaniline	FORBIDDEN											
Nitroanilines (o-,m-,p-)	1661	6.1		Toxic		A113	II	E4	669 Y644	25 kg 1 kg	676	100 kg
Nitroanisoles, liquid	2730	6.1		Toxic		A113	III	E1	655 Y642	60 L 2 L	663	220 L
Nitroanisoles, solid	3458	6.1		Toxic		A113	III	E1	670 Y645	100 kg 10 kg	677	200 kg
Nitrobenzene	1662	6.1		Toxic		A113	II	E4	654 Y641	5 L 1 L	662	60 L
Nitrobenzene bromide, see Nitrobromobenzenes , etc.												
m-Nitrobenzene diazonium perchlorate	FORBIDDEN											
Nitrobenzenesulphonic acid	2305	8		Corrosive			II	E2	851 Y840	1 L 0.5 L	855	30 L
Nitrobenzol, see Nitrobenzene												
5-Nitrobenzotriazol	0385	1.1D							FORBIDDEN		FORBIDDEN	
Nitrobenzotrifluorides, liquid	2306	6.1		Toxic			II	E4	654 Y641	5 L 1 L	662	60 L
Nitrobenzotrifluorides, solid	3431	6.1		Toxic			II	E4	669 Y644	25 kg 1 kg	676	100 kg
Nitrobromobenzene, liquid	2732	6.1		Toxic			III	E1	655 Y642	60 L 2 L	663	220 L
Nitrobromobenzene, solid	3459	6.1		Toxic			III	E1	670 Y645	100 kg 10 kg	677	200 kg
Nitrocellulose , dry or wetted with less than 25% water (or alcohol), by mass	0340	1.1D							FORBIDDEN		FORBIDDEN	
Nitrocellulose , unmodified or plasticized with less than 18% plasticizing substance, by mass	0341	1.1D							FORBIDDEN		FORBIDDEN	
Nitrocellulose membrane filters with not more than 12.6% nitrogen, by dry mass	3270	4.1		Solid flammable		A57 A73 A122	II	E2	458 Y458	1 kg 1 kg	458	15 kg

Name	UN No.	Class or division	Subsidiary risk	Labels	State variations	Special provisions	UN packing group	Excepted quantity	Passenger and cargo aircraft		Cargo aircraft only	
									Packing instruction	Max. net quantity per package	Packing instruction	Max. net quantity per package
1	2	3	4	5	6	7	8	9	10	11	12	13
Nitrocellulose , with not more than 12.6% nitrogen, by dry mass, mixture without plasticizer, without pigment	2557	4.1		Solid flammable	BE 3	A57 A86	II	E0	452	1 kg	453	15 kg
Nitrocellulose , with not more than 12.6% nitrogen, by dry mass, mixture without plasticizer, with pigment	2557	4.1		Solid flammable	BE 3	A57 A86	II	E0	452	1 kg	453	15 kg
Nitrocellulose , with not more than 12.6% nitrogen, by dry mass, mixture with plasticizer, without pigment	2557	4.1		Solid flammable	BE 3	A57 A86	II	E0	452	1 kg	453	15 kg
Nitrocellulose , with not more than 12.6% nitrogen, by dry mass, mixture with plasticizer, with pigment	2557	4.1		Solid flammable	BE 3	A57 A86	II	E0	452	1 kg	453	15 kg
Nitrocellulose, plasticized with not less than 18% plasticizing substance, by mass	0343	1.3C							FORBIDDEN		FORBIDDEN	
Nitrocellulose solution, flammable with not more than 12.6% nitrogen, by dry mass, and not more than 55% nitrocellulose	2059	3		Liquid flammable	BE 3	A3 A91	I II III	E0 E0 E0	351 353 Y341 355 Y344	1 L 5 L 1 L 60 L 10 L	361 364 366	30 L 60 L 220 L
Nitrocellulose, wetted with not less than 25% alcohol, by mass	0342	1.3C							FORBIDDEN		FORBIDDEN	
Nitrocellulose with alcohol , not less than 25% alcohol, by mass, and not more than 12.6% nitrogen, by dry mass	2556	4.1		Solid flammable	BE 3	A57	II	E0	452	1 kg	453	15 kg
Nitrocellulose with water , not less than 25% water by mass	2555	4.1		Solid flammable	BE 3	A57	II	E0	452	15 kg	453	50 kg
Nitrochlorobenzenes, see Chloronitrobenzenes												
3-Nitro-4-chlorobenzotrifluoride	2307	6.1		Toxic			II	E4	654 Y641	5 L 1 L	662	60 L
Nitroresols, liquid	3434	6.1		Toxic			III	E1	655 Y642	60 L 2 L	663	220 L
Nitroresols, solid	2446	6.1		Toxic			III	E1	670 Y645	100 kg 10 kg	677	200 kg
6-Nitro-4-diazotoluene-3-sulphonic acid (dry)	FORBIDDEN											
Nitroethane	2842	3		Liquid flammable			III	E1	355 Y344	60 L 10 L	366	220 L

Name	UN No.	Class or division	Subsidiary risk	Labels	State variations	Special provisions	UN packing group	Excepted quantity	Passenger and cargo aircraft		Cargo aircraft only	
									Packing instruction	Max. net quantity per package	Packing instruction	Max. net quantity per package
1	2	3	4	5	6	7	8	9	10	11	12	13
Nitroethylene polymer	FORBIDDEN											
Nitroethyl nitrate	FORBIDDEN											
Nitrogen, compressed	1066	2.2		Gas non-flammable		A69		E1	200	75 kg	200	150 kg
Nitrogen dioxide	1067	2.3	5.1 8		AU 1 CA 7 IR 3 NL 1 US 3	A2			FORBIDDEN		FORBIDDEN	
Nitrogen, refrigerated liquid	1977	2.2		Gas non-flammable		A152		E1	202	50 kg	202	500 kg
Nitrogen trichloride	FORBIDDEN											
Nitrogen trifluoride	2451	2.2	5.1	Gas non-flammable & Oxidizer	US 18			E0	200	75 kg	200	150 kg
Nitrogen triiodide	FORBIDDEN											
Nitrogen triiodide monoamine	FORBIDDEN											
Nitrogen trioxide	2421	2.3	5.1 8		AU 1 CA 7 IR 3 NL 1 US 3	A2			FORBIDDEN		FORBIDDEN	
Nitroglycerin, desensitized with not less than 40% non-volatile water-insoluble phlegmatizer, by mass	0143	1.1D	6.1						FORBIDDEN		FORBIDDEN	
Nitroglycerin, liquid, not desensitized	FORBIDDEN											
Nitroglycerin mixture, desensitized, liquid, n.o.s.* with not more than 30% nitroglycerin, by mass	3357	3			BE 3				FORBIDDEN		FORBIDDEN	
Nitroglycerin mixture, desensitized, liquid flammable, n.o.s.* with not more than 30% nitroglycerin, by mass	3343	3			BE 3				FORBIDDEN		FORBIDDEN	
Nitroglycerin mixture, desensitized, solid, n.o.s.* with more than 2% but not more than 10% nitroglycerin, by mass	3319	4.1		Solid flammable	AU 1 BE 3 CA 7 IR 3 NL 1 US 3	A1 A68	II	E0	FORBIDDEN		499	0.5 kg

Name	UN No.	Class or division	Subsidiary risk	Labels	State variations	Special provisions	UN packing group	Excepted quantity	Passenger and cargo aircraft		Cargo aircraft only	
									Packing instruction	Max. net quantity per package	Packing instruction	Max. net quantity per package
1	2	3	4	5	6	7	8	9	10	11	12	13
Nitroglycerin solution in alcohol with more than 1% but not more than 10% nitroglycerin	0144	1.1D							FORBIDDEN		FORBIDDEN	
Nitroglycerin solution in alcohol with more than 1% but not more than 5% nitroglycerin	3064	3		Liquid flammable	BE 3	A188	II	E0	FORBIDDEN		371	5 L
Nitroglycerin solution in alcohol with not more than 1% nitroglycerin	1204	3		Liquid flammable	BE 3		II	E0	371 Y341	5 L 1 L	371	60 L
Nitroguanidine , dry or wetted with less than 20% water, by mass	0282	1.1D							FORBIDDEN		FORBIDDEN	
Nitroguanidine nitrate	FORBIDDEN											
Nitroguanidine , wetted with not less than 20% water, by mass	1336	4.1		Solid flammable	BE 3	A40	I	E0	451	1 kg	451	15 kg
1-Nitro hydantoin	FORBIDDEN											
Nitrohydrochloric acid	1798	8		Corrosive	AU 1 CA 7 IR 3 NL 1 US 3	A1	I	E0	FORBIDDEN		854	2.5 L
Nitro isobutane triol trinitrate	FORBIDDEN											
Nitromannite (dry)	FORBIDDEN											
Nitromannite , wetted with not less than 40% water, or mixture of alcohol and water, by mass	0133	1.1D							FORBIDDEN		FORBIDDEN	
Nitromethane	1261	3		Liquid flammable	AU 1 CA 7 IR 3 NL 1 US 3	A1 A39	II	E0	FORBIDDEN		364	60 L
N-Nitro-N-methylglycolamide nitrate	FORBIDDEN											
2-Nitro-2-methylpropanol nitrate	FORBIDDEN											
Nitromuriatic acid, see Nitrohydrochloric acid												
Nitronaphthalene	2538	4.1		Solid flammable			III	E1	446 Y443	25 kg 10 kg	449	100 kg
Nitrophenols (o-,m-,p-)	1663	6.1		Toxic	US 4	A113	III	E1	670 Y645	100 kg 10 kg	677	200 kg

Name	UN No.	Class or division	Subsidiary risk	Labels	State variations	Special provisions	UN packing group	Excepted quantity	Passenger and cargo aircraft		Cargo aircraft only	
									Packing instruction	Max. net quantity per package	Packing instruction	Max. net quantity per package
1	2	3	4	5	6	7	8	9	10	11	12	13
m-Nitrophenyldinitro methane	FORBIDDEN											
4-Nitrophenylhydrazine with not less than 30% water, by mass	3376	4.1			AU 1 CA 7 IR 3 NL 1 US 3	A2			FORBIDDEN		FORBIDDEN	
Nitropropanes	2608	3		Liquid flammable	US 4		III	E1	355 Y344	60 L 10 L	366	220 L
p-Nitrosodimethylaniline	1369	4.2		Spontaneous combustion			II	E2	467	15 kg	470	50 kg
Nitrostarch , dry or wetted with less than 20% water, by mass	0146	1.1D							FORBIDDEN		FORBIDDEN	
Nitrostarch , wetted with not less than 20% water, by mass	1337	4.1		Solid flammable	BE 3	A40	I	E0	451	1 kg	451	15 kg
Nitrosugars (dry)	FORBIDDEN											
Nitrosyl chloride	1069	2.3	8		AU 1 CA 7 IR 3 NL 1 US 3	A2			FORBIDDEN		FORBIDDEN	
Nitrosylsulphuric acid, liquid	2308	8		Corrosive			II	E2	851 Y840	1 L 0.5 L	855	30 L
Nitrosylsulphuric acid, solid	3456	8		Corrosive			II	E2	859 Y844	15 kg 5 kg	863	50 kg
Nitrotoluenes, liquid	1664	6.1		Toxic			II	E4	654 Y641	5 L 1 L	662	60 L
Nitrotoluenes, solid	3446	6.1		Toxic			II	E4	669 Y644	25 kg 1 kg	676	100 kg
Nitrotoluidines (mono)	2660	6.1		Toxic	US 4		III	E1	670 Y645	100 kg 10 kg	677	200 kg
Nitrotriazolone	0490	1.1D							FORBIDDEN		FORBIDDEN	
Nitro urea	0147	1.1D							FORBIDDEN		FORBIDDEN	
Nitrous oxide	1070	2.2	5.1	Gas non-flammable & Oxidizer	US 18			E0	200	75 kg	200	150 kg
Nitrous oxide, refrigerated liquid	2201	2.2	5.1		AU 1 CA 7 IR 3 NL 1 US 3	A2			FORBIDDEN		FORBIDDEN	
Nitroxylenes, liquid	1665	6.1		Toxic			II	E4	654 Y641	5 L 1 L	662	60 L

Name	UN No.	Class or division	Subsidiary risk	Labels	State variations	Special provisions	UN packing group	Excepted quantity	Passenger and cargo aircraft		Cargo aircraft only	
									Packing instruction	Max. net quantity per package	Packing instruction	Max. net quantity per package
1	2	3	4	5	6	7	8	9	10	11	12	13
Nitroxylenes, solid	3447	6.1		Toxic			II	E4	669 Y644	25 kg 1 kg	676	100 kg
Non-activated carbon, see Carbon (UN No. 1361)												
Non-activated charcoal, see Carbon (UN No. 1361)												
Nonanes	1920	3		Liquid flammable			III	E1	355 Y344	60 L 10 L	366	220 L
Non-flammable gas, n.o.s., see Compressed or Liquefied gas , etc.												
Non-liquefied gas, see Compressed gas , etc.												
Non-liquefied hydrocarbon gas, see Hydrocarbon gas, compressed, n.o.s.												
Nonyltrichlorosilane	1799	8		Corrosive	AU 1 CA 7 IR 3 NL 1 US 3	A1	II	E0	FORBIDDEN		876	30 L
2,5-Norbornadiene, stabilized	2251	3		Liquid flammable			II	E2	353 Y341	5 L 1 L	364	60 L
Normal propyl alcohol, see Propyl alcohol, normal												
NTO	0490	1.1D							FORBIDDEN		FORBIDDEN	
O												
Octadecyltrichlorosilane	1800	8		Corrosive	AU 1 CA 7 IR 3 NL 1 US 3	A1	II	E0	FORBIDDEN		876	30 L
Octadiene	2309	3		Liquid flammable			II	E2	353 Y341	5 L 1 L	364	60 L
1,7-Octadiene-3,5-diyne-1,8-dimethoxy-9-octadecynoic acid	FORBIDDEN											
Octafluorobut-2-ene	2422	2.2		Gas non-flammable				E1	200	75 kg	200	150 kg
Octafluorocyclobutane	1976	2.2		Gas non-flammable				E1	200	75 kg	200	150 kg

Name	UN No.	Class or division	Subsidiary risk	Labels	State variations	Special provisions	UN packing group	Excepted quantity	Passenger and cargo aircraft		Cargo aircraft only	
									Packing instruction	Max. net quantity per package	Packing instruction	Max. net quantity per package
1	2	3	4	5	6	7	8	9	10	11	12	13
Octafluoropropane	2424	2.2		Gas non-flammable				E1	200	75 kg	200	150 kg
Octanes	1262	3		Liquid flammable			II	E2	353 Y341	5 L 1 L	364	60 L
Octogen, desensitized	0484	1.1D							FORBIDDEN		FORBIDDEN	
Octogen (dry or unphlegmatized)	FORBIDDEN											
Octogen, wetted with not less than 15% water, by mass	0226	1.1D							FORBIDDEN		FORBIDDEN	
Octol , dry or wetted with less than 15% water, by mass	0266	1.1D							FORBIDDEN		FORBIDDEN	
Octolite , dry or wetted with less than 15% water, by mass	0266	1.1D							FORBIDDEN		FORBIDDEN	
Octonal	0496	1.1D							FORBIDDEN		FORBIDDEN	
Octyl aldehydes	1191	3		Liquid flammable			III	E1	355 Y344	60 L 10 L	366	220 L
tert-Octyl mercaptan, see 2-Methyl-2-heptanethiol												
Octyltrichlorosilane	1801	8		Corrosive	AU 1 CA 7 IR 3 NL 1 US 3	A1	II	E0	FORBIDDEN		876	30 L
Oenanthol, see n-Heptaldehyde												
Oil gas, compressed †	1071	2.3	2.1	Gas toxic & Gas flammable	AU 1 CA 7 IR 3 NL 1 US 3	A1		E0	FORBIDDEN		200	25 kg
Oil well sampling device, charged, see Compressed or Liquefied gas, flammable, n.o.s.												
Oleum, see Sulphuric acid, fuming												
Organic peroxide type B, liquid	FORBIDDEN											
Organic peroxide type B, liquid, temperature controlled	FORBIDDEN											
Organic peroxide type B, solid	FORBIDDEN											

Name	UN No.	Class or division	Subsidiary risk	Labels	State variations	Special provisions	UN packing group	Excepted quantity	Passenger and cargo aircraft		Cargo aircraft only	
									Packing instruction	Max. net quantity per package	Packing instruction	Max. net quantity per package
1	2	3	4	5	6	7	8	9	10	11	12	13
Organic peroxide type B, solid, temperature controlled		FORBIDDEN										
Organic peroxide type C, liquid*	3103	5.2		Organic peroxide		A20 A150		E0	570	5 L	570	10 L
Organic peroxide type C, liquid, temperature controlled*	3113	5.2							FORBIDDEN		FORBIDDEN	
Organic peroxide type C, solid*	3104	5.2		Organic peroxide		A20 A150		E0	570	5 kg	570	10 kg
Organic peroxide type C, solid, temperature controlled*	3114	5.2							FORBIDDEN		FORBIDDEN	
Organic peroxide type D, liquid*	3105	5.2		Organic peroxide		A20 A150		E0	570	5 L	570	10 L
Organic peroxide type D, liquid, temperature controlled*	3115	5.2			AU 1 CA 7 IR 3 NL 1 US 3	A2 A150			FORBIDDEN		FORBIDDEN	
Organic peroxide type D, solid*	3106	5.2		Organic peroxide		A20		E0	570	5 kg	570	10 kg
Organic peroxide type D, solid, temperature controlled*	3116	5.2			AU 1 CA 7 IR 3 NL 1 US 3	A2			FORBIDDEN		FORBIDDEN	
Organic peroxide type E, liquid*	3107	5.2		Organic peroxide		A20 A150		E0	570	10 L	570	25 L
Organic peroxide type E, liquid, temperature controlled*	3117	5.2			AU 1 CA 7 IR 3 NL 1 US 3	A2			FORBIDDEN		FORBIDDEN	
Organic peroxide type E, solid*	3108	5.2		Organic peroxide		A20		E0	570	10 kg	570	25 kg
Organic peroxide type E, solid, temperature controlled*	3118	5.2			AU 1 CA 7 IR 3 NL 1 US 3	A2			FORBIDDEN		FORBIDDEN	
Organic peroxide type F, liquid*	3109	5.2		Organic peroxide		A20 A150		E0	570	10 L	570	25 L
Organic peroxide type F, liquid, temperature controlled*	3119	5.2			AU 1 CA 7 IR 3 NL 1 US 3	A2 A150			FORBIDDEN		FORBIDDEN	

Name	UN No.	Class or division	Subsidiary risk	Labels	State variations	Special provisions	UN packing group	Excepted quantity	Passenger and cargo aircraft		Cargo aircraft only	
									Packing instruction	Max. net quantity per package	Packing instruction	Max. net quantity per package
Organic peroxide type F, solid*	3110	5.2		Organic peroxide		A20		E0	570	10 kg	570	25 kg
Organic peroxide type F, solid, temperature controlled*	3120	5.2			AU 1 CA 7 IR 3 NL 1 US 3	A2			FORBIDDEN		FORBIDDEN	
Organic pigments, self-heating	3313	4.2		Spontaneous combustion		A3	II	E2	467	15 kg	470	50 kg
							III	E1	469	25 kg	471	100 kg
Organoarsenic compound, liquid, n.o.s.*	3280	6.1		Toxic		A3 A4 A137	I	E5	652	1 L	658	30 L
							II	E4	654	5 L	662	60 L
							III	E1	Y641	1 L		
									655	60 L	663	220 L
									Y642	2 L		
Organoarsenic compound, solid, n.o.s.*	3465	6.1		Toxic		A3 A5	I	E5	666	5 kg	673	50 kg
							II	E4	669	25 kg	676	100 kg
							III	E1	Y644	1 kg		
									670	100 kg	677	200 kg
									Y645	10 kg		
Organochlorine pesticide, liquid, flammable, toxic*, flash point less than 23°C	2762	3	6.1	Liquid flammable & Toxic		A4	I	E0	FORBIDDEN		361	30 L
							II	E2	352	1 L	364	60 L
									Y341	1 L		
Organochlorine pesticide, liquid, toxic*	2996	6.1		Toxic		A3 A4	I	E5	652	1 L	658	30 L
							II	E4	654	5 L	662	60 L
							III	E1	Y641	1 L		
									655	60 L	663	220 L
									Y642	2 L		
Organochlorine pesticide, liquid, toxic, flammable*, flash point not less than 23°C	2995	6.1	3	Toxic & Liquid flammable		A3 A4	I	E5	652	1 L	658	30 L
							II	E4	654	5 L	662	60 L
							III	E1	Y641	1 L		
									655	60 L	663	220 L
									Y642	2 L		
Organochlorine pesticide, solid, toxic*	2761	6.1		Toxic		A3 A5	I	E5	666	5 kg	673	50 kg
							II	E4	669	25 kg	676	100 kg
							III	E1	Y644	1 kg		
									670	100 kg	677	200 kg
									Y645	10 kg		
Organometallic compound, liquid, toxic, n.o.s.*	3282	6.1		Toxic		A3 A4	I	E5	652	1 L	658	30 L
							II	E4	654	5 L	662	60 L
							III	E1	Y641	1 L		
									655	60 L	663	220 L
									Y642	2 L		

Name	UN No.	Class or division	Subsidiary risk	Labels	State variations	Special provisions	UN packing group	Excepted quantity	Passenger and cargo aircraft		Cargo aircraft only	
									Packing instruction	Max. net quantity per package	Packing instruction	Max. net quantity per package
1	2	3	4	5	6	7	8	9	10	11	12	13
Organometallic compound, solid, toxic, n.o.s.*	3467	6.1		Toxic		A3 A5	I II III	E5 E4 E1	666	5 kg	673	50 kg
									669	25 kg	676	100 kg
									Y644	1 kg		
									670	100 kg	677	200 kg
									Y645	10 kg		
Organometallic substance, liquid, pyrophoric*	3392	4.2							FORBIDDEN		FORBIDDEN	
Organometallic substance, liquid, pyrophoric, water reactive*	3394	4.2	4.3						FORBIDDEN		FORBIDDEN	
Organometallic substance, liquid, water reactive*	3398	4.3		Danger if wet		A3	I II III	E0 E2 E1	FORBIDDEN		480	1 L
											481	5 L
											482	60 L
Organometallic substance, liquid, water reactive, flammable*	3399	4.3	3	Danger if wet & Liquid flammable		A3	I II III	E0 E2 E1	FORBIDDEN		494	1 L
											494	5 L
											494	60 L
Organometallic substance, solid, pyrophoric*	3391	4.2							FORBIDDEN		FORBIDDEN	
Organometallic substance, solid, pyrophoric, water reactive*	3393	4.2	4.3						FORBIDDEN		FORBIDDEN	
Organometallic substance, solid, self-heating*	3400	4.2		Spontaneous combustion		A3	II III	E2 E1	467	15 kg	470	50 kg
									469	25 kg	471	100 kg
Organometallic substance, solid, water reactive*	3395	4.3		Danger if wet		A3	I II III	E0 E2 E1	FORBIDDEN		487	15 kg
											489	50 kg
											491	100 kg
Organometallic substance, solid, water reactive, flammable*	3396	4.3	4.1	Danger if wet & Solid flammable		A3	I II III	E0 E2 E1	FORBIDDEN		488	15 kg
											489	50 kg
											491	100 kg
Organometallic substance, solid, water reactive, self-heating*	3397	4.3	4.2	Danger if wet & Spontaneous combustion		A3	I II III	E0 E2 E1	FORBIDDEN		488	15 kg
											489	50 kg
											491	100 kg
Organophosphorus compound, liquid, toxic, n.o.s.*	3278	6.1		Toxic		A3 A4 A6 A137	I II III	E5 E4 E1	652	1 L	658	30 L
									654	5 L	662	60 L
									Y641	1 L		
									655	60 L	663	220 L
									Y642	2 L		
Organophosphorus compound, solid, toxic, n.o.s.*	3464	6.1		Toxic		A3 A5 A6	I II III	E5 E4 E1	666	5 kg	673	50 kg
									669	25 kg	676	100 kg
									Y644	1 kg		
									670	100 kg	677	200 kg
									Y645	10 kg		
Organophosphorus compound, toxic, flammable, n.o.s.*	3279	6.1	3	Toxic & Liquid flammable		A4 A6 A137	I II	E5 E4	652	1 L	658	30 L
									654	5 L	662	60 L
									Y641	1 L		

Name	UN No.	Class or division	Subsidiary risk	Labels	State variations	Special provisions	UN packing group	Excepted quantity	Passenger and cargo aircraft		Cargo aircraft only	
									Packing instruction	Max. net quantity per package	Packing instruction	Max. net quantity per package
1	2	3	4	5	6	7	8	9	10	11	12	13
Organophosphorus pesticide, liquid, flammable, toxic* , flash point less than 23°C	2784	3	6.1	Liquid flammable & Toxic		A4	I	E0	FORBIDDEN		361	30 L
								II	E2	352	1 L	364
Organophosphorus pesticide, liquid, toxic*	3018	6.1		Toxic		A3	I	E5	652	1 L	658	30 L
							II	E4	654	5 L	662	60 L
							III	E1	655	60 L	663	220 L
								Y642	2 L			
Organophosphorus pesticide, liquid, toxic, flammable* , flash point not less than 23°C	3017	6.1	3	Toxic & Liquid flammable		A3	I	E5	652	1 L	658	30 L
							II	E4	654	5 L	662	60 L
							III	E1	655	60 L	663	220 L
								Y642	2 L			
Organophosphorus pesticide, solid, toxic*	2783	6.1		Toxic		A3	I	E5	666	5 kg	673	50 kg
							II	E4	669	25 kg	676	100 kg
							III	E1	670	100 kg	677	200 kg
								Y645	10 kg			
Organotin compound, liquid, n.o.s.*	2788	6.1		Toxic		A3	I	E5	652	1 L	658	30 L
							II	E4	654	5 L	661	60 L
							III	E1	655	60 L	663	220 L
								Y642	2 L			
Organotin compound, solid, n.o.s.*	3146	6.1		Toxic		A3	I	E5	666	5 kg	673	50 kg
							II	E4	669	25 kg	676	100 kg
							III	E1	670	100 kg	677	200 kg
								Y645	10 kg			
Organotin pesticide, liquid, flammable, toxic* , flash point less than 23°C	2787	3	6.1	Liquid flammable & Toxic		A4	I	E0	FORBIDDEN		361	30 L
							II	E2	352	1 L	364	60 L
Organotin pesticide, liquid, toxic*	3020	6.1		Toxic		A3	I	E5	652	1 L	658	30 L
							II	E4	654	5 L	662	60 L
							III	E1	655	60 L	663	220 L
								Y642	2 L			
Organotin pesticide, liquid, toxic, flammable* , flash point not less than 23°C	3019	6.1	3	Toxic & Liquid flammable		A3	I	E5	652	1 L	658	30 L
							II	E4	654	5 L	662	60 L
							III	E1	655	60 L	663	220 L
								Y642	2 L			

Name	UN No.	Class or division	Subsidiary risk	Labels	State variations	Special provisions	UN packing group	Excepted quantity	Passenger and cargo aircraft		Cargo aircraft only	
									Packing instruction	Max. net quantity per package	Packing instruction	Max. net quantity per package
1	2	3	4	5	6	7	8	9	10	11	12	13
Organotin pesticide, solid, toxic*	2786	6.1		Toxic		A3 A5	I II III	E5 E4 E1	666	5 kg	673	50 kg
									669	25 kg	676	100 kg
									Y644 670 Y645	1 kg 100 kg 10 kg	677	200 kg
Orthophosphoric acid, see Phosphoric acid, solution (UN No. 1805) or Phosphoric acid, solid (UN No. 3453)												
Osmium tetroxide	2471	6.1		Toxic			I	E5	666	5 kg	673	50 kg
Oxidizing liquid, n.o.s.*	3139	5.1		Oxidizer		A3	I II III	E0 E2 E1	FORBIDDEN		553	2.5 L
									550	1 L	554	5 L
									Y540 551 Y541	0.5 L 2.5 L 1 L	555	30 L
Oxidizing liquid, corrosive, n.o.s.*	3098	5.1	8	Oxidizer & Corrosive		A3	II III	E2 E1	FORBIDDEN		FORBIDDEN	
									550	1 L	554	5 L
									Y540 551 Y541	0.5 L 2.5 L 1 L	555	30 L
Oxidizing liquid, toxic, n.o.s.*	3099	5.1	6.1	Oxidizer & Toxic		A3	I II III	E0 E2 E1	FORBIDDEN		553	2.5 L
									550	1 L	554	5 L
									Y540 551 Y541	0.5 L 2.5 L 1 L	555	30 L
Oxidizing solid, n.o.s.*	1479	5.1		Oxidizer		A3	I II III	E0 E2 E1	557	1 kg	561	15 kg
									558	5 kg	562	25 kg
									Y544 559 Y546	2.5 kg 25 kg 10 kg	563	100 kg
Oxidizing solid, corrosive, n.o.s.*	3085	5.1	8	Oxidizer & Corrosive		A3	I II III	E0 E2 E1	557	1 kg	561	15 kg
									558	5 kg	562	25 kg
									Y544 559 Y545	2.5 kg 25 kg 5 kg	563	100 kg
Oxidizing solid, flammable, n.o.s.*	3137	5.1	4.1						FORBIDDEN		FORBIDDEN	
Oxidizing solid, self-heating, n.o.s.*	3100	5.1	4.2						FORBIDDEN		FORBIDDEN	
Oxidizing solid, toxic, n.o.s.*	3087	5.1	6.1	Oxidizer & Toxic		A3	I II III	E0 E2 E1	557	1 kg	561	15 kg
									558	5 kg	562	25 kg
									Y543 559 Y546	1 kg 25 kg 10 kg	563	100 kg

Name	UN No.	Class or division	Subsidiary risk	Labels	State variations	Special provisions	UN packing group	Excepted quantity	Passenger and cargo aircraft		Cargo aircraft only	
									Packing instruction	Max. net quantity per package	Packing instruction	Max. net quantity per package
1	2	3	4	5	6	7	8	9	10	11	12	13
Oxidizing solid, water-reactive, n.o.s.*	3121	5.1	4.3						FORBIDDEN		FORBIDDEN	
Oxirane, see Ethylene oxide , etc.												
Oxygen, compressed	1072	2.2	5.1	Gas non-flammable & Oxidizer	US 18	A175		E0	200	75 kg	200	150 kg
Oxygen difluoride, compressed	2190	2.3	5.1 8		AU 1 CA 7 IR 3 NL 1 US 3	A2			FORBIDDEN		FORBIDDEN	
≠ Oxygen generator, chemical † (including when contained in associated equipment, e.g. passenger service units (PSUs), protective breathing equipment (PBE), etc.)	3356	5.1		Oxidizer	AU 1 CA 7 FR 7 IR 3 NL 1 US 3 US 18	A1 A111 A116 A144		E0	FORBIDDEN		565	25 kg
Oxygen, refrigerated liquid	1073	2.2	5.1		AU 1 CA 7 IR 3 NL 1 US 3	A2			FORBIDDEN		FORBIDDEN	
1-Oxy-4-nitrobenzene, see Nitrophenols												
P												
+ Packagings, discarded, empty, uncleaned	3509	9				A200		E0	FORBIDDEN		FORBIDDEN	
≠ Paint (including paint, lacquer, enamel, stain, shellac, varnish, polish, liquid filler and liquid lacquer base)	1263	3		Liquid flammable		A3 A72 A192	I II III	E3 E2 E1	351 353 Y341 355 Y344	1 L 5 L 1 L 60 L 10 L	361 364 366	30 L 60 L 220 L
≠ Paint (including paint, lacquer, enamel, stain, shellac, varnish, polish, liquid filler and liquid lacquer base)	3066	8		Corrosive		A3 A72 A192	II III	E2 E1	851 Y840 852 Y841	1 L 0.5 L 5 L 1 L	855 856	30 L 60 L

Name	UN No.	Class or division	Subsidiary risk	Labels	State variations	Special provisions	UN packing group	Excepted quantity	Passenger and cargo aircraft		Cargo aircraft only	
									Packing instruction	Max. net quantity per package	Packing instruction	Max. net quantity per package
1	2	3	4	5	6	7	8	9	10	11	12	13
≠ Paint, corrosive, flammable (including paint, lacquer, enamel, stain, shellac, varnish, polish, liquid filler and liquid lacquer base)	3470	8	3	Corrosive & Liquid flammable		A72 A192	II	E2	851 Y840	1 L 0.5 L	855	30 L
≠ Paint, flammable, corrosive (including paint, lacquer, enamel, stain, shellac, varnish, polish, liquid filler and liquid lacquer base)	3469	3	8	Liquid flammable & Corrosive		A3 A72 A192	I II III	E0 E2 E1	350 352 Y340 354 Y342	0.5 L 1 L 0.5 L 5 L 1 L	360 363 365	2.5 L 5 L 60 L
≠ Paint related material (including paint thinning or reducing compound)	1263	3		Liquid flammable		A3 A72 A192	I II III	E3 E2 E1	351 353 Y341 355 Y344	1 L 5 L 1 L 60 L 10 L	361 364 366	30 L 60 L 220 L
≠ Paint related material (including paint thinning or reducing compound)	3066	8		Corrosive		A3 A72 A192	II III	E2 E1	851 Y840 852 Y841	1 L 0.5 L 5 L 1 L	855 856	30 L 60 L
≠ Paint related material corrosive, flammable (including paint thinning or reducing compound)	3470	8	3	Corrosive & Liquid flammable		A72 A192	II	E2	851 Y840	1 L 0.5 L	855	30 L
≠ Paint related material, flammable, corrosive (including paint thinning or reducing compound)	3469	3	8	Liquid flammable & Corrosive		A3 A72 A192	I II III	E0 E2 E1	350 352 Y340 354 Y342	0.5 L 1 L 0.5 L 5 L 1 L	360 363 365	2.5 L 5 L 60 L
Paper, unsaturated oil treated, incompletely dried (including carbon paper)	1379	4.2			AU 1 CA 7 IR 3 NL 1 US 3	A2			FORBIDDEN		FORBIDDEN	
Paraffin, see Kerosene												
Paraformaldehyde	2213	4.1		Solid flammable			III	E1	446 Y443	25 kg 10 kg	449	100 kg
Paraldehyde	1264	3		Liquid flammable			III	E1	355 Y344	60 L 10 L	366	220 L
PCBs, see Polychlorinated biphenyls												
Pentaborane	1380	4.2	6.1						FORBIDDEN		FORBIDDEN	
Pentachloroethane	1669	6.1		Toxic	US 4		II	E4	654 Y641	5 L 1 L	662	60 L

Name	UN No.	Class or division	Subsidiary risk	Labels	State variations	Special provisions	UN packing group	Excepted quantity	Passenger and cargo aircraft		Cargo aircraft only	
									Packing instruction	Max. net quantity per package	Packing instruction	Max. net quantity per package
1	2	3	4	5	6	7	8	9	10	11	12	13
Pentachlorophenol	3155	6.1		Toxic		A6	II	E4	669 Y644	25 kg 1 kg	676	100 kg
Pentaerythrite tetranitrate with not less than 7% wax, by mass	0411	1.1D							FORBIDDEN		FORBIDDEN	
Pentaerythrite tetranitrate, desensitized with not less than 15% phlegmatizer by mass	0150	1.1D							FORBIDDEN		FORBIDDEN	
Pentaerythrite tetranitrate (dry)	FORBIDDEN											
Pentaerythrite tetranitrate mixture desensitized, solid, n.o.s.* with more than 10% but not more than 20% PETN, by mass	3344	4.1			BE 3				FORBIDDEN		FORBIDDEN	
Pentaerythrite tetranitrate, wetted with not less than 25% water, by mass	0150	1.1D							FORBIDDEN		FORBIDDEN	
Pentaerythritol tetranitrate with not less than 7% wax, by mass	0411	1.1D							FORBIDDEN		FORBIDDEN	
Pentaerythritol tetranitrate, desensitized with not less than 15% phlegmatizer, by mass	0150	1.1D							FORBIDDEN		FORBIDDEN	
Pentaerythritol tetranitrate (dry)	FORBIDDEN											
Pentaerythritol tetranitrate mixture desensitized, solid, n.o.s.* with more than 10% but not more than 20% PETN, by mass	3344	4.1			BE 3				FORBIDDEN		FORBIDDEN	
Pentaerythritol tetranitrate, wetted with not less than 25% water, by mass	0150	1.1D							FORBIDDEN		FORBIDDEN	
Pentafluoroethane	3220	2.2		Gas non-flammable				E1	200	75 kg	200	150 kg
Pentafluoroethane, 1,1,1-trifluoroethane, and 1,1,1,2-tetrafluoroethane zeotropic mixture with approximately 44% pentafluoroethane and 52% 1,1,1-trifluoroethane, see Refrigerant gas R 404A												
Pentamethylheptane	2286	3		Liquid flammable			III	E1	355 Y344	60 L 10 L	366	220 L
Pentanal, see Valeraldehyde												
n-Pentane, see Pentanes, liquid												

Name	UN No.	Class or division	Subsidiary risk	Labels	State variations	Special provisions	UN packing group	Excepted quantity	Passenger and cargo aircraft		Cargo aircraft only	
									Packing instruction	Max. net quantity per package	Packing instruction	Max. net quantity per package
1	2	3	4	5	6	7	8	9	10	11	12	13
Pentane-2,4-dione	2310	3	6.1	Liquid flammable & Toxic			III	E1	355 Y343	60 L 2 L	366	220 L
Pentanes, liquid	1265	3		Liquid flammable			I II	E3 E2	351 353 Y341	1 L 5 L 1 L	361 364	30 L 60 L
Pentanitroaniline (dry)	FORBIDDEN											
3-Pentanol, see Pentanol s (UN No. 1105)												
Pentanol s	1105	3		Liquid flammable		A3	II III	E2 E1	353 Y341 355 Y344	5 L 1 L 60 L 10 L	364 366	60 L 220 L
1-Pentene	1108	3		Liquid flammable			I	E3	351	1 L	361	30 L
1-Pentol	2705	8		Corrosive			II	E2	851 Y840	1 L 0.5 L	855	30 L
Pentolite , dry or wetted with less than 15% water, by mass	0151	1.1D							FORBIDDEN		FORBIDDEN	
Pentyl nitrite, see Amyl nitrite												
Perchlorates, inorganic, n.o.s.	1481	5.1		Oxidizer		A3	II III	E2 E1	558 Y544 559 Y546	5 kg 2.5 kg 25 kg 10 kg	562 563	25 kg 100 kg
Perchlorates, inorganic, aqueous solution, n.o.s.	3211	5.1		Oxidizer		A3	II III	E2 E1	550 Y540 551 Y541	1 L 0.5 L 2.5 L 1 L	554 555	5 L 30 L
Perchloric acid with more than 50% but not more than 72% acid, by mass	1873	5.1	8	Oxidizer & Corrosive			I	E0	FORBIDDEN		553	2.5 L
Perchloric acid with not more than 50% acid, by mass	1802	8	5.1	Corrosive & Oxidizer	AU 1 CA 7 IR 3 NL 1 US 3	A1	II	E0	FORBIDDEN		855	30 L
Perchloric acid with more than 72% acid, by mass	FORBIDDEN											
Perchlorobenzene, see Hexachlorobenzene												

Name	UN No.	Class or division	Subsidiary risk	Labels	State variations	Special provisions	UN packing group	Excepted quantity	Passenger and cargo aircraft		Cargo aircraft only	
									Packing instruction	Max. net quantity per package	Packing instruction	Max. net quantity per package
1	2	3	4	5	6	7	8	9	10	11	12	13
Perchlorocyclopentadiene, see Hexachlorocyclopentadiene												
Perchloroethylene, see Tetrachloroethylene												
Perchloromethyl mercaptan	1670	6.1			US 4				FORBIDDEN		FORBIDDEN	
Perchloryl fluoride	3083	2.3	5.1		AU 1 CA 7 IR 3 NL 1 US 3	A2			FORBIDDEN		FORBIDDEN	
Perfluoroacetylchloride, see Trifluoroacetyl chloride												
Perfluoro (ethyl vinyl ether)	3154	2.1		Gas flammable	AU 1 CA 7 IR 3 NL 1 US 3	A1		E0	FORBIDDEN		200	150 kg
Perfluoro (methyl vinyl ether)	3153	2.1		Gas flammable	AU 1 CA 7 IR 3 NL 1 US 3	A1		E0	FORBIDDEN		200	150 kg
Perfluoropropane, see Octafluoropropane												
Perfumery products with flammable solvents	1266	3		Liquid flammable		A3 A72	II	E2	353 Y341	5 L 1 L	364	60 L
							III	E1	355 Y344	60 L 10 L	366	220 L
Permanganates, inorganic, n.o.s.*	1482	5.1		Oxidizer		A3 A37 A173	II	E2	558 Y544	5 kg 2.5 kg	562	25 kg
							III	E1	559 Y546	25 kg 10 kg	563	100 kg
Permanganates, inorganic, aqueous solution, n.o.s.*	3214	5.1		Oxidizer		A37 A173	II	E2	550 Y540	1 L 0.5 L	554	5 L
Permeation devices for calibrating air quality monitoring equipment, see Special Provision A41												
Peroxide, organic, see Organic peroxide , etc.												

Name	UN No.	Class or division	Subsidiary risk	Labels	State variations	Special provisions	UN packing group	Excepted quantity	Passenger and cargo aircraft		Cargo aircraft only	
									Packing instruction	Max. net quantity per package	Packing instruction	Max. net quantity per package
1	2	3	4	5	6	7	8	9	10	11	12	13
Peroxides, inorganic, n.o.s.	1483	5.1		Oxidizer		A3	II	E2	558 Y544	5 kg 2.5 kg	562	25 kg
							III	E1	559 Y546	25 kg 10 kg	563	100 kg
Peroxyacetic acid, more than 43% and with more than 6% hydrogen peroxide	FORBIDDEN											
Persulphates, inorganic, n.o.s.	3215	5.1		Oxidizer			III	E1	559 Y546	25 kg 10 kg	563	100 kg
Persulphates, inorganic, aqueous solution, n.o.s.	3216	5.1		Oxidizer			III	E1	551 Y541	2.5 L 1 L	555	30 L
Pesticide, liquid, flammable, toxic, n.o.s.* , flash point less than 23°C	3021	3	6.1	Liquid flammable & Toxic		A4	I	E0	FORBIDDEN		361	30 L
							II	E2	352 Y341	1 L 1 L	364	60 L
Pesticide, liquid, toxic, n.o.s.*	2902	6.1		Toxic		A3 A4	I	E5	652	1 L	658	30 L
							II	E4	654 Y641	5 L 1 L	662	60 L
							III	E1	655 Y642	60 L 2 L	663	220 L
Pesticide, liquid, toxic, flammable, n.o.s.* , flash point not less than 23°C	2903	6.1	3	Toxic & Liquid flammable		A3 A4	I	E5	652	1 L	658	30 L
							II	E4	654 Y641	5 L 1 L	662	60 L
							III	E1	655 Y642	60 L 2 L	663	220 L
Pesticide, solid, toxic, n.o.s.*	2588	6.1		Toxic		A3 A5	I	E5	666	5 kg	673	50 kg
							II	E4	669 Y644	25 kg 1 kg	676	100 kg
							III	E1	670 Y645	100 kg 10 kg	677	200 kg
Pesticide, toxic, under compressed gas, n.o.s., see Aerosols												
PETN/TNT, see Pentolite , etc.												
PETN with not less than 7% wax, by mass	0411	1.1D							FORBIDDEN		FORBIDDEN	
PETN, desensitized with not less than 15% phlegmatizer, by mass	0150	1.1D							FORBIDDEN		FORBIDDEN	
PETN (dry)	FORBIDDEN											
PETN mixture desensitized, solid, n.o.s.* with more than 10% but not more than 20% PETN, by mass	3344	4.1			BE 3				FORBIDDEN		FORBIDDEN	

Name	UN No.	Class or division	Subsidiary risk	Labels	State variations	Special provisions	UN packing group	Excepted quantity	Passenger and cargo aircraft		Cargo aircraft only	
									Packing instruction	Max. net quantity per package	Packing instruction	Max. net quantity per package
1	2	3	4	5	6	7	8	9	10	11	12	13
PETN, wetted with not less than 25% water, by mass	0150	1.1D							FORBIDDEN		FORBIDDEN	
Petrol	1203	3		Liquid flammable		A100	II	E2	353 Y341	5 L 1 L	364	60 L
Petroleum crude oil	1267	3		Liquid flammable		A3 A177	I II	E3 E2	351 353 Y341	1 L 5 L 1 L	361 364	30 L 60 L
							III	E1	355 Y344	60 L 10 L	366	220 L
Petroleum distillates, n.o.s.	1268	3		Liquid flammable		A3	I II	E3 E2	351 353 Y341	1 L 5 L 1 L	361 364	30 L 60 L
Petroleum ether, see Petroleum distillates, n.o.s.							III	E1	355 Y344	60 L 10 L	366	220 L
Petroleum gases, liquefied	1075	2.1		Gas flammable	AU 1 CA 7 IR 3 NL 1 US 3	A1		E0	FORBIDDEN		200	150 kg
Petroleum naphtha, see Petroleum distillates, n.o.s.												
Petroleum oil, see Petroleum products, n.o.s.												
Petroleum products, n.o.s.	1268	3		Liquid flammable		A3	I II	E3 E2	351 353 Y341	1 L 5 L 1 L	361 364	30 L 60 L
							III	E1	355 Y344	60 L 10 L	366	220 L
Petroleum raffinate, see Petroleum distillates, n.o.s.												
Petroleum sour crude oil, flammable, toxic	3494	3	6.1	Liquid flammable & Toxic		A166	I II	E0 E2	FORBIDDEN 352 Y341	1 L 1 L	361 364	30 L 60 L
							III	E1	355 Y343	60 L 2 L	366	220 L
Petroleum spirit, see Petroleum distillates, n.o.s.												
Phenacyl bromide	2645	6.1		Toxic			II	E4	669 Y644	25 kg 1 kg	676	100 kg

Name	UN No.	Class or division	Subsidiary risk	Labels	State variations	Special provisions	UN packing group	Excepted quantity	Passenger and cargo aircraft		Cargo aircraft only	
									Packing instruction	Max. net quantity per package	Packing instruction	Max. net quantity per package
1	2	3	4	5	6	7	8	9	10	11	12	13
Phenetidines	2311	6.1		Toxic		A113	III	E1	655 Y642	60 L 2 L	663	220 L
Phenolates, liquid	2904	8		Corrosive			III	E1	852 Y841	5 L 1 L	856	60 L
Phenolates, solid	2905	8		Corrosive			III	E1	860 Y845	25 kg 5 kg	864	100 kg
Phenol, molten	2312	6.1							FORB	DDEN	FORB	DDEN
Phenol, solid	1671	6.1		Toxic		A113	II	E4	669 Y644	25 kg 1 kg	676	100 kg
Phenol solution	2821	6.1		Toxic		A3	II	E4	654 Y641	5 L 1 L	662	60 L
							III	E1	655 Y642	60 L 2 L	663	220 L
Phenolsulphonic acid, liquid	1803	8		Corrosive			II	E2	851 Y840	1 L 0.5 L	855	30 L
Phenoxyacetic acid derivative pesticide, liquid, flammable, toxic*, flash point less than 23°C	3346	3	6.1	Liquid flammable & Toxic		A4	I	E0	FORB	DDEN	361	30 L
							II	E2	352 Y341	1 L 1 L	364	60 L
Phenoxyacetic acid derivative pesticide, liquid, toxic*	3348	6.1		Toxic		A3 A4	I II	E5 E4	652 654 Y641	1 L 5 L 1 L	658 662	30 L 60 L
							III	E1	655 Y642	60 L 2 L	663	220 L
Phenoxyacetic acid derivative pesticide, liquid, toxic, flammable*, flash point not less than 23°C	3347	6.1	3	Toxic & Liquid flammable		A3 A4	I II	E5 E4	652 654 Y641	1 L 5 L 1 L	658 662	30 L 60 L
							III	E1	655 Y642	60 L 2 L	663	220 L
Phenoxyacetic acid derivative pesticide, solid, toxic*	3345	6.1		Toxic		A3 A5	I II	E5 E4	666 669 Y644	5 kg 25 kg 1 kg	673 676	50 kg 100 kg
							III	E1	670 Y645	100 kg 10 kg	677	200 kg
Phenylacetonitrile, liquid	2470	6.1		Toxic			III	E1	655 Y642	60 L 2 L	663	220 L
Phenylacetyl chloride	2577	8		Corrosive			II	E2	851 Y840	1 L 0.5 L	855	30 L
Phenylamine, see Aniline												
1-Phenylbutane, see Butylbenzenes												
2-Phenylbutane, see Butylbenzenes												

Name	UN No.	Class or division	Subsidiary risk	Labels	State variations	Special provisions	UN packing group	Excepted quantity	Passenger and cargo aircraft		Cargo aircraft only	
									Packing instruction	Max. net quantity per package	Packing instruction	Max. net quantity per package
1	2	3	4	5	6	7	8	9	10	11	12	13
Phenylcarbylamine chloride	1672	6.1							FORBIDDEN		FORBIDDEN	
Phenyl chloroformate	2746	6.1	8	Toxic & Corrosive			II	E4	653 Y641	1 L 1 L	660	30 L
Phenyl cyanide, see Benzonitrile												
m-Phenylene diaminediperchlorate (dry)	FORBIDDEN											
Phenylenediamines (o-,m-,p-)	1673	6.1		Toxic		A113	III	E1	670 Y645	100 kg 10 kg	677	200 kg
Phenylethylene, see Styrene monomer, stabilized (UN No. 2055)												
Phenylhydrazine	2572	6.1		Toxic			II	E4	654 Y641	5 L 1 L	662	60 L
Phenyl isocyanate	2487	6.1	3						FORBIDDEN		FORBIDDEN	
Phenylisocyanodichloride, see Phenylcarbylamine chloride												
Phenyl mercaptan	2337	6.1	3		US 4				FORBIDDEN		FORBIDDEN	
Phenylmercuric acetate	1674	6.1		Toxic	US 4	A6	II	E4	669 Y644	25 kg 1 kg	676	100 kg
Phenylmercuric compound, n.o.s.*	2026	6.1		Toxic		A3 A5 A6	I II III	E5 E4 E1	666 669 670 Y644 Y645	5 kg 25 kg 100 kg 1 kg 10 kg	673 676 677	50 kg 100 kg 200 kg
Phenylmercuric hydroxide	1894	6.1		Toxic			II	E4	669 Y644	25 kg 1 kg	676	100 kg
Phenylmercuric nitrate	1895	6.1		Toxic			II	E4	669 Y644	25 kg 1 kg	676	100 kg
Phenylphosphorus dichloride	2798	8		Corrosive	AU 1 CA 7 IR 3 NL 1 US 3	A1	II	E0	FORBIDDEN		855	30 L
Phenylphosphorus thiodichloride	2799	8		Corrosive	AU 1 CA 7 IR 3 NL 1 US 3	A1	II	E0	FORBIDDEN		855	30 L
2-Phenylpropene, see Isopropenylbenzene												

Name	UN No.	Class or division	Subsidiary risk	Labels	State variations	Special provisions	UN packing group	Excepted quantity	Passenger and cargo aircraft		Cargo aircraft only	
									Packing instruction	Max. net quantity per package	Packing instruction	Max. net quantity per package
1	2	3	4	5	6	7	8	9	10	11	12	13
Phenyltrichlorosilane	1804	8		Corrosive	AU 1 CA 7 IR 3 NL 1 US 3	A1	II	E0	FORBIDDEN		876	30 L
Phosgene	1076	2.3	8		AU 1 CA 7 IR 3 NL 1 US 3	A2			FORBIDDEN		FORBIDDEN	FORBIDDEN
9-Phosphabicyclononanes	2940	4.2		Spontaneous combustion			II	E2	467	15 kg	470	50 kg
Phosphine	2199	2.3	2.1		AU 1 CA 7 IR 3 NL 1 US 3	A2			FORBIDDEN		FORBIDDEN	FORBIDDEN
+ Phosphine, adsorbed Phosphoretted hydrogen, see Phosphine Phosphoric acid, anhydrous, see Phosphorus pentoxide	3525	2.3	2.1			A2		E0	FORBIDDEN		FORBIDDEN	FORBIDDEN
Phosphoric acid, solid	3453	8		Corrosive			III	E1	860 Y845	25 kg 5 kg	864	100 kg
Phosphoric acid, solution	1805	8		Corrosive		A3	III	E1	852 Y841	5 L 1 L	856	60 L
Phosphorous acid	2834	8		Corrosive			III	E1	860 Y845	25 kg 5 kg	864	100 kg
Phosphorous (V) sulphide, free from yellow and white phosphorous, see Phosphorous pentasulphide												
Phosphorus, amorphous	1338	4.1		Solid flammable			III	E1	446 Y443	25 kg 10 kg	449	100 kg
Phosphorus bromide, see Phosphorus tribromide												
Phosphorus chloride, see Phosphorus trichloride												
Phosphorus heptasulphide , free from yellow and white phosphorus	1339	4.1		Solid flammable			II	E2	445 Y441	15 kg 5 kg	448	50 kg

Name	UN No.	Class or division	Subsidiary risk	Labels	State variations	Special provisions	UN packing group	Excepted quantity	Passenger and cargo aircraft		Cargo aircraft only	
									Packing instruction	Max. net quantity per package	Packing instruction	Max. net quantity per package
1	2	3	4	5	6	7	8	9	10	11	12	13
Phosphorus oxybromide	1939	8		Corrosive	AU 1 CA 7 IR 3 NL 1 US 3	A1	II	E0	FORBIDDEN		863	50 kg
Phosphorus oxybromide, molten	2576	8							FORBIDDEN		FORBIDDEN	
Phosphorus oxychloride	1810	6.1	8		AU 1 CA 7 IR 3 NL 1 US 3	A2			FORBIDDEN		FORBIDDEN	
Phosphorus pentabromide	2691	8		Corrosive	AU 1 CA 7 IR 3 NL 1 US 3	A1	II	E0	FORBIDDEN		863	50 kg
Phosphorus pentachloride	1806	8		Corrosive	AU 1 CA 7 IR 3 NL 1 US 3	A1	II	E0	FORBIDDEN		863	50 kg
Phosphorus pentafluoride	2198	2.3	8		AU 1 CA 7 IR 3 NL 1 US 3	A2			FORBIDDEN		FORBIDDEN	
+ Phosphorus pentafluoride, adsorbed	3524	2.3	8			A2		E0	FORBIDDEN		FORBIDDEN	
Phosphorus pentasulphide, free from yellow and white phosphorus	1340	4.3	4.1	Danger if wet & Solid flammable	US 4		II	E2	483 Y475	15 kg 5 kg	490	50 kg
Phosphorus pentoxide	1807	8		Corrosive			II	E2	859 Y844	15 kg 5 kg	863	50 kg
Phosphorus sesquisulphide, free from yellow and white phosphorus	1341	4.1		Solid flammable			II	E2	445 Y441	15 kg 5 kg	448	50 kg
Phosphorus sulphochloride, see Thiophosphoryl chloride												
Phosphorus tribromide	1808	8		Corrosive	AU 1 CA 7 IR 3 NL 1 US 3	A1	II	E0	FORBIDDEN		855	30 L
Phosphorus trichloride	1809	6.1	8						FORBIDDEN		FORBIDDEN	
Phosphorus trioxide	2578	8		Corrosive			III	E1	860 Y845	25 kg 5 kg	864	100 kg

Name	UN No.	Class or division	Subsidiary risk	Labels	State variations	Special provisions	UN packing group	Excepted quantity	Passenger and cargo aircraft		Cargo aircraft only	
									Packing instruction	Max. net quantity per package	Packing instruction	Max. net quantity per package
1	2	3	4	5	6	7	8	9	10	11	12	13
Phosphorus trisulphide , free from yellow and white phosphorus	1343	4.1		Solid flammable			II	E2	445 Y441	15 kg 5 kg	448	50 kg
Phosphorus, white, dry	1381	4.2	6.1						FORBIDDEN		FORBIDDEN	
Phosphorus, white, in solution	1381	4.2	6.1						FORBIDDEN		FORBIDDEN	
Phosphorus, white, molten	2447	4.2	6.1						FORBIDDEN		FORBIDDEN	
Phosphorus (white or red) and a chlorate, mixture of	FORBIDDEN											
Phosphorus, white, under water	1381	4.2	6.1						FORBIDDEN		FORBIDDEN	
Phosphorus, yellow, dry	1381	4.2	6.1						FORBIDDEN		FORBIDDEN	
Phosphorus, yellow, in solution	1381	4.2	6.1						FORBIDDEN		FORBIDDEN	
Phosphorus, yellow, under water	1381	4.2	6.1						FORBIDDEN		FORBIDDEN	
Phosphoryl chloride, see Phosphorus oxychloride												
Phthalic anhydride with more than 0.05% of maleic anhydride	2214	8		Corrosive		A74	III	E1	860 Y845	25 kg 5 kg	864	100 kg
Picolines	2313	3		Liquid flammable			III	E1	355 Y344	60 L 10 L	366	220 L
Picramide	0153	1.1D							FORBIDDEN		FORBIDDEN	
Picric acid , dry or wetted with less than 30% water, by mass	0154	1.1D							FORBIDDEN		FORBIDDEN	
Picric acid, wetted with not less than 30% water, by mass	1344	4.1		Solid flammable	BE 3	A40	I	E0	451	1 kg	451	15 kg
Picric acid, wetted with not less than 10% water, by mass	3364	4.1		Solid flammable	BE 3	A40	I	E0	451	0.5 kg	451	0.5 kg
Picrite , dry or wetted with less than 20% water, by mass	0282	1.1D							FORBIDDEN		FORBIDDEN	
Picrite, wetted with not less than 20% water by mass	1336	4.1		Solid flammable	BE 3	A40	I	E0	451	1 kg	451	15 kg
Picrotoxin, see Toxins, extracted from living sources, liquid, n.o.s. (UN No. 3172) or Toxins, extracted from living sources, solid, n.o.s. (UN No. 3462)												
Picryl chloride	0155	1.1D							FORBIDDEN		FORBIDDEN	
Picryl chloride, wetted with not less than 10% water, by mass	3365	4.1		Solid flammable	BE 3	A40	I	E0	451	0.5 kg	451	0.5 kg

Name	UN No.	Class or division	Subsidiary risk	Labels	State variations	Special provisions	UN packing group	Excepted quantity	Passenger and cargo aircraft		Cargo aircraft only	
									Packing instruction	Max. net quantity per package	Packing instruction	Max. net quantity per package
1	2	3	4	5	6	7	8	9	10	11	12	13
alpha-Pinene	2368	3		Liquid flammable			III	E1	355 Y344	60 L 10 L	366	220 L
Pine oil	1272	3		Liquid flammable			III	E1	355 Y344	60 L 10 L	366	220 L
Piperazine	2579	8		Corrosive			III	E1	860 Y845	25 kg 5 kg	864	100 kg
Piperidine	2401	8	3	Corrosive & Liquid flammable			I	E0	850	0.5 L	854	2.5 L
Pivaloyl chloride, see Trimethylacetyl chloride												
Plastic explosives, see Explosive, blasting, type D												
Plastics moulding compound in dough, sheet or extruded rope form evolving flammable vapour	3314	9		Miscellaneous		A38	III	E1	957	100 kg	957	200 kg
Plastics, nitrocellulose-based, self-heating, n.o.s.*	2006	4.2			AU 1 CA 7 IR 3 NL 1 US 3	A2			FORBIDDEN		FORBIDDEN	
Plastic solvent, n.o.s. †, see Flammable liquid, n.o.s.												
Plutonium nitrate solution, see Part 2, Chapter 7												
Poisonous, see Toxic												
Polyamines, flammable, corrosive, n.o.s.*	2733	3	8	Liquid flammable & Corrosive		A3	I II III	E0 E2 E1	350 352 Y340 354 Y342	0.5 L 1 L 0.5 L 5 L 1 L	360 363 365	2.5 L 5 L 60 L
Polyamines, liquid, corrosive, n.o.s.*	2735	8		Corrosive		A3	I II III	E0 E2 E1	850 851 Y840 852 Y841	0.5 L 1 L 0.5 L 5 L 1 L	854 855 856	2.5 L 30 L 60 L
Polyamines, liquid, corrosive, flammable, n.o.s.*	2734	8	3	Corrosive & Liquid flammable			I II	E0 E2	850 851 Y840	0.5 L 1 L 0.5 L	854 855	2.5 L 30 L

Name	UN No.	Class or division	Subsidiary risk	Labels	State variations	Special provisions	UN packing group	Excepted quantity	Passenger and cargo aircraft		Cargo aircraft only		
									Packing instruction	Max. net quantity per package	Packing instruction	Max. net quantity per package	
1	2	3	4	5	6	7	8	9	10	11	12	13	
Polyamines, solid, corrosive, n.o.s.*	3259	8		Corrosive		A3	I	E0	858	1 kg	862	25 kg	
									859	15 kg		863	50 kg
									Y844	5 kg		864	100 kg
									860	25 kg			
									Y845	5 kg			
Polychlorinated biphenyls, liquid	2315	9		Miscellaneous	US 4	A11	II	E2	964	100 L	964	220 L	
Polychlorinated biphenyls, solid	3432	9		Miscellaneous	US 4	A11	II	E2	956	100 kg	956	200 kg	
Polyester resin kit †	3269	3		Liquid flammable		A66 A163	II	E0	370	5 kg	370	5 kg	
									Y370	1 kg		370	10 kg
									370	10 kg			
							III	E0	370	5 kg			
Polyhalogenated biphenyls, liquid	3151	9		Miscellaneous		A11 A95	II	E2	964	100 L	964	220 L	
Polyhalogenated biphenyls, solid	3152	9		Miscellaneous		A11 A95	II	E2	956	100 kg	956	200 kg	
Polyhalogenated terphenyls, liquid	3151	9		Miscellaneous		A11 A95	II	E2	964	100 L	964	220 L	
Polyhalogenated terphenyls, solid	3152	9		Miscellaneous		A11 A95	II	E2	956	100 kg	956	200 kg	
Polymeric beads, expandable, evolving flammable vapour †	2211	9		Miscellaneous		A38	III	E1	957	100 kg	957	200 kg	
Polystyrene beads, expandable, etc., see Polymeric beads, expandable , evolving flammable vapour													
Potassium	2257	4.3		Danger if wet	AU 1 CA 7 IR 3 NL 1 US 3	A1	I	E0	FORBIDDEN		487	15 kg	
Potassium arsenate	1677	6.1		Toxic	US 4		II	E4	669 Y644	25 kg 1 kg	676	100 kg	
Potassium arsenite	1678	6.1		Toxic	US 4		II	E4	669 Y644	25 kg 1 kg	676	100 kg	
Potassium bifluoride, see Potassium hydrogendifluoride, solid (UN No. 1811)													
Potassium bisulphate, see Potassium hydrogen sulphate													
Potassium bisulphite solution, see Bisulphites, aqueous solution, n.o.s.													

Name	UN No.	Class or division	Subsidiary risk	Labels	State variations	Special provisions	UN packing group	Excepted quantity	Passenger and cargo aircraft		Cargo aircraft only	
									Packing instruction	Max. net quantity per package	Packing instruction	Max. net quantity per package
1	2	3	4	5	6	7	8	9	10	11	12	13
Potassium borohydride	1870	4.3		Danger if wet			I	E0	FORBIDDEN		487	15 kg
Potassium bromate	1484	5.1		Oxidizer			II	E2	558 Y544	5 kg 2.5 kg	562	25 kg
Potassium carbonyl	FORBIDDEN											
Potassium chlorate	1485	5.1		Oxidizer			II	E2	558 Y544	5 kg 2.5 kg	562	25 kg
Potassium chlorate, aqueous solution	2427	5.1		Oxidizer		A3	II	E2	550 Y540	1 L 0.5 L	554	5 L
							III	E1	551 Y541	2.5 L 1 L	555	30 L
Potassium chlorate mixed with mineral oil, see Explosive, blasting, type C												
Potassium cuprocyanide	1679	6.1		Toxic			II	E4	669 Y644	25 kg 1 kg	676	100 kg
Potassium cyanide, solid	1680	6.1		Toxic	US 4		I	E5	666	5 kg	673	50 kg
Potassium cyanide solution	3413	6.1		Toxic		A3	I	E5	652	1 L	658	30 L
							II	E4	654 Y641	5 L 1 L	662	60 L
							III	E1	655 Y642	60 L 2 L	663	220 L
Potassium dicyanocuprate, (I), see Potassium cuprocyanide												
Potassium dithionite	1929	4.2		Spontaneous combustion			II	E2	467	15 kg	470	50 kg
Potassium fluoride, solid	1812	6.1		Toxic			III	E1	670 Y645	100 kg 10 kg	677	200 kg
Potassium fluoride solution	3422	6.1		Toxic		A3	III	E1	655 Y642	60 L 2 L	663	220 L
Potassium fluoroacetate	2628	6.1		Toxic			I	E5	666	5 kg	673	50 kg
Potassium fluorosilicate	2655	6.1		Toxic			III	E1	670 Y645	100 kg 10 kg	677	200 kg
Potassium hexafluorosilicate, see Potassium fluorosilicate												
Potassium hydrate, see Potassium hydroxide, solid												
Potassium hydrogendifluoride, solid	1811	8	6.1	Corrosive & Toxic			II	E2	859 Y844	15 kg 5 kg	863	50 kg

Name	UN No.	Class or division	Subsidiary risk	Labels	State variations	Special provisions	UN packing group	Excepted quantity	Passenger and cargo aircraft		Cargo aircraft only		
									Packing instruction	Max. net quantity per package	Packing instruction	Max. net quantity per package	
1	2	3	4	5	6	7	8	9	10	11	12	13	
Potassium hydrogendifluoride solution	3421	8	6.1	Corrosive & Toxic		A3	II	E2	851	1 L	855	30 L	
									Y840	0.5 L		856	60 L
									852	5 L			
									Y841	1 L			
Potassium hydrogen sulphate	2509	8		Corrosive			II	E2	859	15 kg	863	50 kg	
									Y844	5 kg			
Potassium hydrosulphite	1929	4.2		Spontaneous combustion			II	E2	467	15 kg	470	50 kg	
Potassium hydroxide, liquid, see Potassium hydroxide solution													
Potassium hydroxide, solid	1813	8		Corrosive			II	E2	859	15 kg	863	50 kg	
									Y844	5 kg			
Potassium hydroxide solution	1814	8		Corrosive		A3	II	E2	851	1 L	855	30 L	
									Y840	0.5 L		856	60 L
									852	5 L			
									Y841	1 L			
Potassium metal alloys, liquid	1420	4.3		Danger if wet	AU 1 CA 7 IR 3 NL 1 US 3	A1	I	E0	FORBIDDEN		480	1 L	
Potassium metal alloys, solid	3403	4.3		Danger if wet			I	E0	FORBIDDEN		487	15 kg	
Potassium metavanadate	2864	6.1		Toxic			II	E4	669	25 kg	676	100 kg	
									Y644	1 kg			
Potassium monoxide	2033	8		Corrosive			II	E2	859	15 kg	863	50 kg	
									Y844	5 kg			
Potassium nitrate	1486	5.1		Oxidizer			III	E1	559	25 kg	563	100 kg	
									Y546	10 kg			
Potassium nitrate and sodium nitrate mixture, see Sodium nitrate and potassium nitrate mixture													
Potassium nitrate and sodium nitrite mixture	1487	5.1		Oxidizer			II	E2	558	5 kg	562	25 kg	
									Y544	2.5 kg			
Potassium nitrite	1488	5.1		Oxidizer			II	E2	558	5 kg	562	25 kg	
									Y544	2.5 kg			
Potassium perchlorate	1489	5.1		Oxidizer			II	E2	558	5 kg	562	25 kg	
									Y544	2.5 kg			
Potassium permanganate	1490	5.1		Oxidizer			II	E2	558	5 kg	562	25 kg	
									Y544	2.5 kg			
Potassium peroxide	1491	5.1		Oxidizer	AU 1 CA 7 IR 3 NL 1 US 3	A1	I	E0	FORBIDDEN		561	15 kg	

Name	UN No.	Class or division	Subsidiary risk	Labels	State variations	Special provisions	UN packing group	Excepted quantity	Passenger and cargo aircraft		Cargo aircraft only	
									Packing instruction	Max. net quantity per package	Packing instruction	Max. net quantity per package
1	2	3	4	5	6	7	8	9	10	11	12	13
Potassium persulphate	1492	5.1		Oxidizer			III	E1	559 Y546	25 kg 10 kg	563	100 kg
Potassium phosphide	2012	4.3	6.1	Danger if wet & Toxic			I	E0	FORBIDDEN		487	15 kg
Potassium selenate, see Selenates												
Potassium selenite, see Selenites												
Potassium silicofluoride, see Potassium fluorosilicate												
Potassium sodium alloys, liquid †	1422	4.3		Danger if wet	AU 1 CA 7 IR 3 NL 1 US 3	A1	I	E0	FORBIDDEN		480	1 L
Potassium sodium alloys, solid	3404	4.3		Danger if wet			I	E0	FORBIDDEN		487	15 kg
Potassium sulphide with less than 30% water of crystallization	1382	4.2		Spontaneous combustion			II	E2	467	15 kg	470	50 kg
Potassium sulphide, anhydrous †	1382	4.2		Spontaneous combustion			II	E2	467	15 kg	470	50 kg
Potassium sulphide, hydrated with not less than 30% water of crystallization	1847	8		Corrosive			II	E2	859 Y844	15 kg 5 kg	863	50 kg
Potassium superoxide	2466	5.1		Oxidizer	AU 1 CA 7 IR 3 NL 1 US 3	A1	I	E0	FORBIDDEN		561	15 kg
Potassium tetracyanomercurate, (II), see Mercuric potassium cyanide												
Powder cake, wetted with not less than 17% alcohol, by mass †	0433	1.1C							FORBIDDEN		FORBIDDEN	
Powder cake, wetted with not less than 25% water, by mass †	0159	1.3C							FORBIDDEN		FORBIDDEN	
Powder paste, wetted with not less than 17% alcohol, by mass †	0433	1.1C							FORBIDDEN		FORBIDDEN	
Powder paste, wetted with not less than 25% water, by mass	0159	1.3C							FORBIDDEN		FORBIDDEN	
Powder, smokeless †	0160	1.1C							FORBIDDEN		FORBIDDEN	
Powder, smokeless †	0161	1.3C							FORBIDDEN		FORBIDDEN	

Name	UN No.	Class or division	Subsidiary risk	Labels	State variations	Special provisions	UN packing group	Excepted quantity	Passenger and cargo aircraft		Cargo aircraft only	
									Packing instruction	Max. net quantity per package	Packing instruction	Max. net quantity per package
									10	11	12	13
Powder, smokeless †	0509	1.4C		Explosive 1.4					FORBIDDEN		114	75 kg
Power devices, explosive, see Cartridges, power device												
Pressurized products, see Aerosols etc.												
Primers, cap type †	0044	1.4S		Explosive 1.4				E0	133	25 kg	133	100 kg
Primers, cap type †	0377	1.1B							FORBIDDEN		FORBIDDEN	
Primers, cap type †	0378	1.4B		Explosive 1.4				E0	FORBIDDEN		133	75 kg
Primers, small arms, see Primers, cap type												
Primers, tubular †	0319	1.3G							FORBIDDEN		FORBIDDEN	
Primers, tubular †	0320	1.4G		Explosive 1.4				E0	FORBIDDEN		133	75 kg
Primers, tubular †	0376	1.4S		Explosive 1.4				E0	133	25 kg	133	100 kg
≠ Printing ink, flammable	1210	3		Liquid flammable		A3 A72 A192	I II III	E3 E2 E1	351 353 Y341 355 Y344	1 L 5 L 1 L 60 L 10 L	361 364 366	30 L 60 L 220 L
≠ Printing ink related material (including printing ink thinning or reducing compound), flammable	1210	3		Liquid flammable		A3 A72 A192	I II III	E3 E2 E1	351 353 Y341 355 Y344	1 L 5 L 1 L 60 L 10 L	361 364 366	30 L 60 L 220 L
Projectiles, inert with tracer †	0345	1.4S		Explosive 1.4				E0	130	25 kg	130	100 kg
Projectiles, inert with tracer †	0424	1.3G							FORBIDDEN		FORBIDDEN	
Projectiles, inert with tracer †	0425	1.4G		Explosive 1.4				E0	FORBIDDEN		130	75 kg
Projectiles with burster or expelling charge †	0346	1.2D							FORBIDDEN		FORBIDDEN	
Projectiles with burster or expelling charge †	0347	1.4D		Explosive 1.4				E0	FORBIDDEN		130	75 kg
Projectiles with burster or expelling charge †	0426	1.2F							FORBIDDEN		FORBIDDEN	
Projectiles with burster or expelling charge †	0427	1.4F							FORBIDDEN		FORBIDDEN	
Projectiles with burster or expelling charge †	0434	1.2G							FORBIDDEN		FORBIDDEN	

Name	UN No.	Class or division	Subsidiary risk	Labels	State variations	Special provisions	UN packing group	Excepted quantity	Passenger and cargo aircraft		Cargo aircraft only	
									Packing instruction	Max. net quantity per package	Packing instruction	Max. net quantity per package
1	2	3	4	5	6	7	8	9	10	11	12	13
Projectiles with burster or expelling charge †	0435	1.4G		Explosive 1.4				E0	FORBIDDEN		130	75 kg
Projectiles with bursting charge †	0167	1.1F							FORBIDDEN		FORBIDDEN	
Projectiles with bursting charge †	0168	1.1D							FORBIDDEN		FORBIDDEN	
Projectiles with bursting charge †	0169	1.2D							FORBIDDEN		FORBIDDEN	
Projectiles with bursting charge †	0324	1.2F							FORBIDDEN		FORBIDDEN	
Projectiles with bursting charge †	0344	1.4D		Explosive 1.4				E0	FORBIDDEN		130	75 kg
Projectiles, illuminating, see Ammunition, illuminating , etc.												
Propadiene and methyl acetylene mixture, stabilized, see Methyl acetylene and propadiene mixture, stabilized												
Propadiene, stabilized	2200	2.1		Gas flammable	AU 1 CA 7 IR 3 NL 1 US 3	A1		E0	FORBIDDEN		200	150 kg
Propane	1978	2.1		Gas flammable	AU 1 CA 7 IR 3 NL 1 US 3	A1		E0	FORBIDDEN		200	150 kg
Propanethiols	2402	3		Liquid flammable			II	E2	353 Y341	5 L 1 L	364	60 L
n-Propanol	1274	3		Liquid flammable		A3	II	E2	353 Y341	5 L 1 L	364	60 L
							III	E1	355 Y344	60 L 10 L	366	220 L
Propellant, liquid †	0495	1.3C							FORBIDDEN		FORBIDDEN	
Propellant, liquid †	0497	1.1C							FORBIDDEN		FORBIDDEN	
Propellant, single, double or triple base, see Powder, smokeless												
Propellant, solid †	0498	1.1C							FORBIDDEN		FORBIDDEN	
Propellant, solid †	0499	1.3C							FORBIDDEN		FORBIDDEN	
Propellant, solid	0501	1.4C							FORBIDDEN		FORBIDDEN	
Propene, see Propylene												

Name	UN No.	Class or division	Subsidiary risk	Labels	State variations	Special provisions	UN packing group	Excepted quantity	Passenger and cargo aircraft		Cargo aircraft only	
									Packing instruction	Max. net quantity per package	Packing instruction	Max. net quantity per package
1	2	3	4	5	6	7	8	9	10	11	12	13
Propionaldehyde	1275	3		Liquid flammable			II	E2	353 Y341	5 L 1 L	364	60 L
Propionic acid with not less than 90% acid by mass	3463	8	3	Corrosive & Liquid flammable			II	E2	851 Y840	1 L 0.5 L	855	30 L
Propionic acid with not less than 10% and less than 90% acid by mass	1848	8		Corrosive			III	E1	852 Y841	5 L 1 L	856	60 L
Propionic anhydride	2496	8		Corrosive			III	E1	852 Y841	5 L 1 L	856	60 L
Propionitrile	2404	3	6.1	Liquid flammable & Toxic	AU 1 CA 7 IR 3 NL 1 US 3	A1	II	E0	FORBIDDEN		364	60 L
Propionyl chloride	1815	3	8	Liquid flammable & Corrosive			II	E2	352 Y340	1 L 0.5 L	363	5 L
n-Propyl acetate	1276	3		Liquid flammable			II	E2	353 Y341	5 L 1 L	364	60 L
Propyl alcohol, normal	1274	3		Liquid flammable		A3	II	E2	353 Y341	5 L 1 L	364	60 L
							III	E1	355 Y344	60 L 10 L	366	220 L
Propylamine	1277	3	8	Liquid flammable & Corrosive			II	E2	352 Y340	1 L 0.5 L	363	5 L
n-Propylbenzene	2364	3		Liquid flammable			III	E1	355 Y344	60 L 10 L	366	220 L
Propyl chloride, see 1-Chloropropane												
n-Propyl chloroformate	2740	6.1	3 8						FORBIDDEN		FORBIDDEN	
Propylene	1077	2.1		Gas flammable	AU 1 CA 7 IR 3 NL 1 US 3	A1		E0	FORBIDDEN		200	150 kg
Propylene chlorohydrin	2611	6.1	3	Toxic & Liquid flammable			II	E4	654 Y641	5 L 1 L	662	60 L
1,2-Propylenediamine	2258	8	3	Corrosive & Liquid flammable			II	E2	851 Y840	1 L 0.5 L	855	30 L
Propylene dichloride, see 1,2-Dichloropropane												

Name	UN No.	Class or division	Subsidiary risk	Labels	State variations	Special provisions	UN packing group	Excepted quantity	Passenger and cargo aircraft		Cargo aircraft only	
									Packing instruction	Max. net quantity per package	Packing instruction	Max. net quantity per package
1	2	3	4	5	6	7	8	9	10	11	12	13
Propyleneimine, stabilized	1921	3	6.1	Liquid flammable & Toxic	US 4		I	E0	FORBIDDEN		361	30 L
Propylene or liquefied petroleum gas, see Petroleum gases, liquefied												
Propylene oxide	1280	3		Liquid flammable			I	E3	351	1 L	361	30 L
Propylene tetramer	2850	3		Liquid flammable			III	E1	355 Y344	60 L 10 L	366	220 L
Propylene trimer, see Trippropylene												
Propyl formates	1281	3		Liquid flammable			II	E2	353 Y341	5 L 1 L	364	60 L
n-Propyl isocyanate	2482	6.1	3						FORBIDDEN		FORBIDDEN	
Propyl mercaptan, see Propanethiols												
n-Propyl nitrate	1865	3		Liquid flammable			II	E2	353 Y341	5 L 1 L	364	60 L
Propyltrichlorosilane	1816	8	3	Corrosive & Liquid flammable	AU 1 CA 7 IR 3 NL 1 US 3	A1	II	E0	FORBIDDEN		876	30 L
Pyrazine hexahydride, see Piperazine												
Pyrethroid pesticide, liquid flammable, toxic* , flash point less than 23°C	3350	3	6.1	Liquid flammable & Toxic		A4	I II	E0 E2	FORBIDDEN 352 Y341	1 L 1 L	361 364	30 L 60 L
Pyrethroid pesticide, liquid, toxic*	3352	6.1		Toxic		A3 A4	I II III	E5 E4 E1	652 654 Y641 655 Y642	1 L 5 L 1 L 60 L 2 L	658 662 663	30 L 60 L 220 L
Pyrethroid pesticide, liquid, toxic, flammable* , flash point not less than 23°C	3351	6.1	3	Toxic & Liquid flammable		A3 A4	I II III	E5 E4 E1	652 654 Y641 655 Y642	1 L 5 L 1 L 60 L 2 L	658 662 663	30 L 60 L 220 L
Pyrethroid pesticide, solid, toxic*	3349	6.1		Toxic		A3 A5	I II III	E5 E4 E1	666 669 Y644 670 Y645	5 kg 25 kg 1 kg 100 kg 10 kg	673 676 677	50 kg 100 kg 200 kg

Name	UN No.	Class or division	Subsidiary risk	Labels	State variations	Special provisions	UN packing group	Excepted quantity	Passenger and cargo aircraft		Cargo aircraft only	
									Packing instruction	Max. net quantity per package	Packing instruction	Max. net quantity per package
1	2	3	4	5	6	7	8	9	10	11	12	13
Pyridine	1282	3		Liquid flammable			II	E2	353 Y341	5 L 1 L	364	60 L
Pyridine perchlorate	FORBIDDEN											
Pyrophoric alloy, n.o.s.*	1383	4.2							FORBIDDEN		FORBIDDEN	
Pyrophoric liquid, inorganic, n.o.s.* †	3194	4.2							FORBIDDEN		FORBIDDEN	
Pyrophoric liquid, organic, n.o.s.* †	2845	4.2							FORBIDDEN		FORBIDDEN	
Pyrophoric metal, n.o.s.*	1383	4.2							FORBIDDEN		FORBIDDEN	
Pyrophoric solid, inorganic, n.o.s.* †	3200	4.2							FORBIDDEN		FORBIDDEN	
Pyrophoric solid, organic, n.o.s.* †	2846	4.2							FORBIDDEN		FORBIDDEN	
Pyrosulphuryl chloride	1817	8		Corrosive			II	E2	851 Y840	1 L 0.5 L	855	30 L
Pyroxylin solution †, see Nitrocellulose solution, flammable												
Pyrrolidine	1922	3	8	Liquid flammable & Corrosive			II	E2	352 Y340	1 L 0.5 L	363	5 L
Q												
Quebrachitol pentanitrate	FORBIDDEN											
Quinoline	2656	6.1		Toxic			III	E1	655 Y642	60 L 2 L	663	220 L
Quinone, see Benzoquinone												
R												
Radioactive material, excepted package — articles manufactured from natural uranium or depleted uranium or natural thorium	2909	7		None		A130			See Part 1;6			
Radioactive material, excepted package — empty packaging	2908	7		None		A130			See Part 1;6			
Radioactive material, excepted package — instruments or articles	2911	7		None		A130			See Part 1;6			
≠ Radioactive material, excepted package — limited quantity of material	2910	7		None		A130 A193			See Part 1;6			

Name	UN No.	Class or division	Subsidiary risk	Labels	State variations	Special provisions	UN packing group	Excepted quantity	Passenger and cargo aircraft		Cargo aircraft only	
									Packing instruction	Max. net quantity per package	Packing instruction	Max. net quantity per package
1	2	3	4	5	6	7	8	9	10	11	12	13
Radioactive material, low specific activity (LSA-I), non-fissile or fissile excepted	2912	7		Radioactive	CA 1	A23 A78 A139				See Part 2;7 and Part 4;9		
Radioactive material, low specific activity (LSA-II), non-fissile or fissile excepted	3321	7		Radioactive	CA 1	A23 A78 A139 A159				See Part 2;7 and Part 4;9		
Radioactive material, low specific activity (LSA-II), fissile	3324	7		Radioactive	CA 1	A76 A78 A159				See Part 2;7 and Part 4;9		
Radioactive material, low specific activity (LSA-III), non-fissile or fissile excepted	3322	7		Radioactive	CA 1	A23 A78 A139 A159				See Part 2;7 and Part 4;9		
Radioactive material, low specific activity (LSA-III), fissile	3325	7		Radioactive	CA 1	A76 A78 A159				See Part 2;7 and Part 4;9		
Radioactive material, surface contaminated objects (SCO-I or SCO-II), non-fissile or fissile excepted	2913	7		Radioactive	CA 1	A78 A139 A159				See Part 2;7 and Part 4;9		
Radioactive material, surface contaminated objects (SCO-I or SCO-II), fissile	3326	7		Radioactive	CA 1	A76 A78 A159				See Part 2;7 and Part 4;9		
Radioactive material, transported under special arrangement, non-fissile or fissile excepted	2919	7		Radioactive	CA 1	A23 A78 A139				See Part 2;7 and Part 4;9		
Radioactive material, transported under special arrangement, fissile	3331	7		Radioactive	CA 1	A76 A78				See Part 2;7 and Part 4;9		
Radioactive material, Type A package, non-special form, non-fissile or fissile excepted	2915	7		Radioactive	CA 1	A23 A78 A139				See Part 2;7 and Part 4;9		
Radioactive material, Type A package, fissile, non-special form	3327	7		Radioactive	CA 1	A78				See Part 2;7 and Part 4;9		
Radioactive material, Type A package, special form, non-fissile or fissile excepted	3332	7		Radioactive	CA 1	A78 A139				See Part 2;7 and Part 4;9		
Radioactive material, Type A package, special form, fissile	3333	7		Radioactive	CA 1	A78				See Part 2;7 and Part 4;9		

Name	UN No.	Class or division	Subsidiary risk	Labels	State variations	Special provisions	UN packing group	Excepted quantity	Passenger and cargo aircraft		Cargo aircraft only	
									Packing instruction	Max. net quantity per package	Packing instruction	Max. net quantity per package
1	2	3	4	5	6	7	8	9	10	11	12	13
Radioactive material, Type B(M) package , non-fissile or fissile excepted	2917	7		Radioactive	CA 1	A23 A78 A139 A160				See Part 2;7	and Part 4;9	
Radioactive material, Type B(M) package , fissile	3329	7		Radioactive	CA 1	A76 A78 A160				See Part 2;7	and Part 4;9	
Radioactive material, Type B(U) package , non-fissile or fissile excepted	2916	7		Radioactive	CA 1	A23 A78 A139 A160				See Part 2;7	and Part 4;9	
Radioactive material, Type B(U) package , fissile	3328	7		Radioactive	CA 1	A76 A78 A160				See Part 2;7	and Part 4;9	
Radioactive material, Type C package , non-fissile or fissile excepted	3323	7		Radioactive	CA 1	A23 A78 A139				See Part 2;7	and Part 4;9	
Radioactive material, Type C package , fissile	3330	7		Radioactive	CA 1	A76 A78				See Part 2;7	and Part 4;9	
Radioactive material, uranium hexafluoride , non-fissile or fissile excepted	2978	7	8	Radioactive & Corrosive	CA 1	A139				See Part 2;7	and Part 4;9	
Radioactive material, uranium hexafluoride , fissile	2977	7	8	Radioactive & Corrosive						See Part 2;7	and Part 4;9	
+ Rags, oily	1856	4.2				A2				FORBIDDEN	FORBIDDEN	
RDX and cyclotetramethylene-tetranitramine mixture, desensitized with not less than 10% phlegmatizer, by mass	0391	1.1D								FORBIDDEN	FORBIDDEN	
RDX and cyclotetramethylene-tetranitramine mixture, wetted with not less than 15% water, by mass	0391	1.1D								FORBIDDEN	FORBIDDEN	
RDX, desensitized	0483	1.1D								FORBIDDEN	FORBIDDEN	
RDX, wetted with not less than 15% water, by mass	0072	1.1D								FORBIDDEN	FORBIDDEN	
Receptacles, small, containing gas (flammable) without a release device, non-refillable	2037	2.1		Gas flammable		A167		E0	203 Y203	1 kg 1 kg	203	15 kg
Receptacles, small, containing gas (non-flammable) without a release device, non-refillable	2037	2.2		Gas non-flammable		A98 A167		E0	203 Y203	1 kg 1 kg	203	15 kg

Name	UN No.	Class or division	Subsidiary risk	Labels	State variations	Special provisions	UN packing group	Excepted quantity	Passenger and cargo aircraft		Cargo aircraft only	
									Packing instruction	Max. net quantity per package	Packing instruction	Max. net quantity per package
1	2	3	4	5	6	7	8	9	10	11	12	13
Receptacles, small, containing gas (oxidizing) without a release device, non-refillable	2037	2.2	5.1	Gas non-flammable & Oxidizer		A167		E0	203	1 kg	203	15 kg
Receptacles, small, containing gas (toxic & corrosive) without a release device, non-refillable	2037	2.3	8		AU 1 CA 7 IR 3 NL 1 US 3	A2			FORBIDDEN		FORBIDDEN	
Receptacles, small, containing gas (toxic, flammable & corrosive) without a release device, non-refillable	2037	2.3	2.1 8		AU 1 CA 7 IR 3 NL 1 US 3	A2			FORBIDDEN		FORBIDDEN	
Receptacles, small, containing gas (toxic & flammable) without a release device, non-refillable	2037	2.3	2.1		AU 1 CA 7 IR 3 NL 1 US 3	A2			FORBIDDEN		FORBIDDEN	
Receptacles, small, containing gas (toxic, oxidizing & corrosive) without a release device, non-refillable	2037	2.3	5.1 8		AU 1 CA 7 IR 3 NL 1 US 3	A2			FORBIDDEN		FORBIDDEN	
Receptacles, small, containing gas (toxic & oxidizing) without a release device, non-refillable	2037	2.3	5.1		AU 1 CA 7 IR 3 NL 1 US 3	A2			FORBIDDEN		FORBIDDEN	
Receptacles, small, containing gas (toxic) without a release device, non-refillable	2037	2.3			AU 1 CA 7 IR 3 NL 1 US 3	A2			FORBIDDEN		FORBIDDEN	
Red phosphorus, see Phosphorus, amorphous												
Refrigerant gas, n.o.s.*	1078	2.2		Gas non-flammable				E1	200	75 kg	200	150 kg
Refrigerant gas R 12	1028	2.2		Gas non-flammable				E1	200	75 kg	200	150 kg
Refrigerant gas R 12B1	1974	2.2		Gas non-flammable				E1	200	75 kg	200	150 kg
Refrigerant gas R 13	1022	2.2		Gas non-flammable				E1	200	75 kg	200	150 kg

Name	UN No.	Class or division	Subsidiary risk	Labels	State variations	Special provisions	UN packing group	Excepted quantity	Passenger and cargo aircraft		Cargo aircraft only	
									Packing instruction	Max. net quantity per package	Packing instruction	Max. net quantity per package
1	2	3	4	5	6	7	8	9	10	11	12	13
Refrigerant gas R 13B1	1009	2.2		Gas non-flammable				E1	200	75 kg	200	150 kg
Refrigerant gas R 14	1982	2.2		Gas non-flammable				E1	200	75 kg	200	150 kg
Refrigerant gas R 21	1029	2.2		Gas non-flammable				E1	200	75 kg	200	150 kg
Refrigerant gas R 22	1018	2.2		Gas non-flammable				E1	200	75 kg	200	150 kg
Refrigerant gas R 23	1984	2.2		Gas non-flammable				E1	200	75 kg	200	150 kg
Refrigerant gas R 32	3252	2.1		Gas flammable	AU 1 CA 7 IR 3 NL 1 US 3	A1		E0	FORBIDDEN		200	150 kg
Refrigerant gas R 40	1063	2.1		Gas flammable	AU 1 CA 7 IR 3 NL 1 US 3	A1		E0	FORBIDDEN		200	100 kg
Refrigerant gas R 41	2454	2.1		Gas flammable	AU 1 CA 7 IR 3 NL 1 US 3	A1		E0	FORBIDDEN		200	150 kg
Refrigerant gas R 114	1958	2.2		Gas non-flammable				E1	200	75 kg	200	150 kg
Refrigerant gas R 115	1020	2.2		Gas non-flammable				E1	200	75 kg	200	150 kg
Refrigerant gas R 116	2193	2.2		Gas non-flammable				E1	200	75 kg	200	150 kg
Refrigerant gas R 124	1021	2.2		Gas non-flammable				E1	200	75 kg	200	150 kg
Refrigerant gas R 125	3220	2.2		Gas non-flammable				E1	200	75 kg	200	150 kg
Refrigerant gas R 133a	1983	2.2		Gas non-flammable				E1	200	75 kg	200	150 kg
Refrigerant gas R 134a	3159	2.2		Gas non-flammable				E1	200	75 kg	200	150 kg
Refrigerant gas R 142b	2517	2.1		Gas flammable	AU 1 CA 7 IR 3 NL 1 US 3	A1		E0	FORBIDDEN		200	150 kg
Refrigerant gas R 143a	2035	2.1		Gas flammable	AU 1 CA 7 IR 3 NL 1 US 3	A1		E0	FORBIDDEN		200	150 kg

Name	UN No.	Class or division	Subsidiary risk	Labels	State variations	Special provisions	UN packing group	Excepted quantity	Passenger and cargo aircraft		Cargo aircraft only	
									Packing instruction	Max. net quantity per package	Packing instruction	Max. net quantity per package
1	2	3	4	5	6	7	8	9	10	11	12	13
Refrigerant gas R 152a	1030	2.1		Gas flammable	AU 1 CA 7 IR 3 NL 1 US 3	A1		E0	FORBIDDEN		200	150 kg
Refrigerant gas R 161	2453	2.1		Gas flammable	AU 1 CA 7 IR 3 NL 1 US 3	A1		E0	FORBIDDEN		200	150 kg
Refrigerant gas R 218	2424	2.2		Gas non-flammable				E1	200	75 kg	200	150 kg
Refrigerant gas R 227	3296	2.2		Gas non-flammable				E1	200	75 kg	200	150 kg
Refrigerant gas R 404A	3337	2.2		Gas non-flammable				E1	200	75 kg	200	150 kg
Refrigerant gas R 407A	3338	2.2		Gas non-flammable				E1	200	75 kg	200	150 kg
Refrigerant gas R 407B	3339	2.2		Gas non-flammable				E1	200	75 kg	200	150 kg
Refrigerant gas R 407C	3340	2.2		Gas non-flammable				E1	200	75 kg	200	150 kg
Refrigerant gas R 500	2602	2.2		Gas non-flammable				E1	200	75 kg	200	150 kg
Refrigerant gas R 502	1973	2.2		Gas non-flammable				E1	200	75 kg	200	150 kg
Refrigerant gas R 503	2599	2.2		Gas non-flammable				E1	200	75 kg	200	150 kg
+ Refrigerant gas R 1113	1082	2.3	2.1		AU 1 CA 7 IR 3 NL 1 US 3	A2			FORBIDDEN		FORBIDDEN	
Refrigerant gas R 1132a	1959	2.1		Gas flammable	AU 1 CA 7 IR 3 NL 1 US 3	A1		E0	FORBIDDEN		200	150 kg
Refrigerant gas R 1216	1858	2.2		Gas non-flammable				E1	200	75 kg	200	150 kg
Refrigerant gas R 1318	2422	2.2		Gas non-flammable				E1	200	75 kg	200	150 kg
Refrigerant gas R C318	1976	2.2		Gas non-flammable				E1	200	75 kg	200	150 kg
Refrigerating machines containing flammable, non-toxic, liquefied gas	3358	2.1						A103	FORBIDDEN		FORBIDDEN	
Refrigerating machines containing non-flammable, non-toxic gases or ammonia solutions (UN 2672)	2857	2.2		Gas non-flammable				A26	See 211		See 211	

Name	UN No.	Class or division	Sub-sidiary risk	Labels	State variations	Special provisions	UN packing group	Excepted quantity	Passenger and cargo aircraft		Cargo aircraft only	
									Packing instruction	Max. net quantity per package	Packing instruction	Max. net quantity per package
1	2	3	4	5	6	7	8	9	10	11	12	13
Refrigerating machines containing toxic, liquefied gas or ammonia solution with more than 50% ammonia		FORBIDDEN										
Regulated medical waste, n.o.s.	3291	6.2		Infectious		A117	II	E0	622	No limit	622	No limit
Release devices, explosive †	0173	1.4S		Explosive 1.4				E0	134	25 kg	134	100 kg
Resin solution, flammable	1866	3		Liquid flammable		A3	I II III	E3 E2 E1	351 353 Y341 355 Y344	1 L 5 L 1 L 60 L 10 L	361 364 366	30 L 60 L 220 L
Resorcin, see Resorcinol												
Resorcinol	2876	6.1		Toxic			III	E1	670 Y645	100 kg 10 kg	677	200 kg
Rivets, explosive	0174	1.4S		Explosive 1.4				E0	134	25 kg	134	100 kg
Rocket motors †	0186	1.3C		Explosive				E0	FORBIDDEN		130	220 kg
Rocket motors †	0280	1.1C							FORBIDDEN		FORBIDDEN	
Rocket motors †	0281	1.2C							FORBIDDEN		FORBIDDEN	
Rocket motors, liquid fuelled †	0395	1.2J							FORBIDDEN		FORBIDDEN	
Rocket motors, liquid fuelled †	0396	1.3J							FORBIDDEN		FORBIDDEN	
Rocket motors with hypergolic liquids with or without expelling charge †	0250	1.3L							FORBIDDEN		FORBIDDEN	
Rocket motors with hypergolic liquids with or without expelling charge †	0322	1.2L							FORBIDDEN		FORBIDDEN	
Rockets with bursting charge †	0180	1.1F							FORBIDDEN		FORBIDDEN	
Rockets with bursting charge †	0181	1.1E							FORBIDDEN		FORBIDDEN	
Rockets with bursting charge †	0182	1.2E							FORBIDDEN		FORBIDDEN	
Rockets with bursting charge †	0295	1.2F							FORBIDDEN		FORBIDDEN	
Rockets with expelling charge †	0436	1.2C							FORBIDDEN		FORBIDDEN	
Rockets with expelling charge †	0437	1.3C							FORBIDDEN		FORBIDDEN	
Rockets with expelling charge †	0438	1.4C		Explosive 1.4				E0	FORBIDDEN		130	75 kg
Rockets with inert head †	0183	1.3C							FORBIDDEN		FORBIDDEN	
Rockets with inert head †	0502	1.2C							FORBIDDEN		FORBIDDEN	

Name	UN No.	Class or division	Subsidiary risk	Labels	State variations	Special provisions	UN packing group	Excepted quantity	Passenger and cargo aircraft		Cargo aircraft only	
									Packing instruction	Max. net quantity per package	Packing instruction	Max. net quantity per package
1	2	3	4	5	6	7	8	9	10	11	12	13
Rockets, line-throwing †	0238	1.2G							FORBIDDEN		FORBIDDEN	
Rockets, line-throwing †	0240	1.3G		Explosive				E0	FORBIDDEN		130	75 kg
Rockets, line-throwing †	0453	1.4G		Explosive 1.4				E0	FORBIDDEN		130	75 kg
Rockets, liquid fuelled with bursting charge †	0397	1.1J							FORBIDDEN		FORBIDDEN	
Rockets, liquid fuelled with bursting charge †	0398	1.2J							FORBIDDEN		FORBIDDEN	
Rosin oil	1286	3		Liquid flammable		A3	II	E2	353 Y341	5 L 1 L	364	60 L
							III	E1	355 Y344	60 L 10 L	366	220 L
Rubber scrap, powdered or granulated, not exceeding 840 microns and rubber content exceeding 45%	1345	4.1		Solid flammable		A3	II	E2	445 Y441	15 kg 5 kg	448	50 kg
Rubber shoddy, powdered or granulated, not exceeding 840 microns and rubber content exceeding 45%	1345	4.1		Solid flammable		A3	II	E2	445 Y441	15 kg 5 kg	448	50 kg
Rubber solution	1287	3		Liquid flammable		A3	II	E2	353 Y341	5 L 1 L	364	60 L
							III	E1	355 Y344	60 L 10 L	366	220 L
Rubidium	1423	4.3		Danger if wet			I	E0	FORBIDDEN		487	15 kg
Rubidium hydroxide	2678	8		Corrosive			II	E2	859 Y844	15 kg 5 kg	863	50 kg
Rubidium hydroxide solution	2677	8		Corrosive		A3	II	E2	851 Y840	1 L 0.5 L	855	30 L
							III	E1	852 Y841	5 L 1 L	856	60 L
S												
≠ Safety devices, electrically initiated†	3268	9		Miscellaneous	BE 3 US 16	A32 A115 A119		E0	961	25 kg	961	100 kg
≠ Safety devices, pyrotechnic †	0503	1.4G		Explosive 1.4		A32 A56		E0	FORBIDDEN		135	75 kg
Saltpetre, see Potassium nitrate												
Samples, explosive* , other than initiating explosives	0190	1							FORBIDDEN		FORBIDDEN	

Name	UN No.	Class or division	Subsidiary risk	Labels	State variations	Special provisions	UN packing group	Excepted quantity	Passenger and cargo aircraft		Cargo aircraft only	
									Packing instruction	Max. net quantity per package	Packing instruction	Max. net quantity per package
1	2	3	4	5	6	7	8	9	10	11	12	13
Sand acid, see Fluorosilicic acid												
+ Seat-belt pretensioners, see Safety devices (UN No. 3268) or Safety devices, pyrotechnic (UN No. 0503)												
Security type equipment †	FORBIDDEN					A178						
Seed cake with more than 1.5% oil and not more than 11% moisture	1386	4.2			AU 1 CA 7 IR 3 NL 1 US 3	A2			FORBIDDEN		FORBIDDEN	
Seed cake with not more than 1.5% oil and not more than 11% moisture	2217	4.2			AU 1 CA 7 IR 3 NL 1 US 3	A2 A55			FORBIDDEN		FORBIDDEN	
Seed expellers, see Seed cake , etc.												
Selenates*	2630	6.1		Toxic	US 4		I	E5	666	5 kg	673	50 kg
Selenic acid	1905	8		Corrosive	AU 1 CA 7 IR 3 NL 1 US 3	A1	I	E0	FORBIDDEN		862	25 kg
Selenites*	2630	6.1		Toxic	US 4		I	E5	666	5 kg	673	50 kg
Selenium compound, liquid, n.o.s.*	3440	6.1		Toxic		A3 A4	I II	E5 E4	652 654 Y641 655 Y642	1 L 5 L 1 L 60 L 2 L	658 662	30 L 60 L 220 L
Selenium compound, solid, n.o.s.*	3283	6.1		Toxic		A3 A5	I II	E5 E4	666 669 Y644 670 Y645	5 kg 25 kg 1 kg 100 kg 10 kg	673 676 677	50 kg 100 kg 200 kg
Selenium disulphide	2657	6.1		Toxic	US 4		II	E4	669 Y644	25 kg 1 kg	676	100 kg
Selenium hexafluoride	2194	2.3	8		AU 1 CA 7 IR 3 NL 1 US 3	A2			FORBIDDEN		FORBIDDEN	

Name	UN No.	Class or division	Subsidiary risk	Labels	State variations	Special provisions	UN packing group	Excepted quantity	Passenger and cargo aircraft		Cargo aircraft only	
									Packing instruction	Max. net quantity per package	Packing instruction	Max. net quantity per package
1	2	3	4	5	6	7	8	9	10	11	12	13
Selenium nitride	FORBIDDEN											
Selenium oxychloride	2879	8	6.1	Corrosive & Toxic			I	E0	850	0.5 L	854	2.5 L
Self-heating liquid, corrosive, inorganic, n.o.s.*	3188	4.2	8	Spontaneous combustion & Corrosive		A3	II III	E2 E1	462 463	1 L 5 L	464 465	5 L 60 L
Self-heating liquid, corrosive, organic, n.o.s.*	3185	4.2	8	Spontaneous combustion & Corrosive		A3	II III	E2 E1	462 463	1 L 5 L	464 465	5 L 60 L
Self-heating liquid, inorganic, n.o.s.*	3186	4.2		Spontaneous combustion		A3	II III	E2 E1	462 463	1 L 5 L	464 465	5 L 60 L
Self-heating liquid, organic, n.o.s.*	3183	4.2		Spontaneous combustion		A3	II III	E2 E1	462 463	1 L 5 L	464 465	5 L 60 L
Self-heating liquid, toxic, inorganic, n.o.s.*	3187	4.2	6.1	Spontaneous combustion & Toxic		A3	II III	E2 E1	462 463	1 L 5 L	464 465	5 L 60 L
Self-heating liquid, toxic, organic, n.o.s.*	3184	4.2	6.1	Spontaneous combustion & Toxic		A3	II III	E2 E1	462 463	1 L 5 L	464 465	5 L 60 L
Self-heating solid, corrosive, inorganic, n.o.s.*	3192	4.2	8	Spontaneous combustion & Corrosive		A3	II III	E2 E1	466 468	15 kg 25 kg	470 471	50 kg 100 kg
Self-heating solid, corrosive, organic, n.o.s.*	3126	4.2	8	Spontaneous combustion & Corrosive		A3	II III	E2 E1	466 468	15 kg 25 kg	470 471	50 kg 100 kg
Self-heating solid, inorganic, n.o.s.*	3190	4.2		Spontaneous combustion		A3	II III	E2 E1	467 469	15 kg 25 kg	470 471	50 kg 100 kg
Self-heating solid, organic, n.o.s.*	3088	4.2		Spontaneous combustion		A3	II III	E2 E1	467 469	15 kg 25 kg	470 471	50 kg 100 kg
Self-heating solid, oxidizing, n.o.s.*	3127	4.2	5.1		AU 1 CA 7 IR 3 NL 1 US 3	A2 A3			FORBIDDEN		FORBIDDEN	
Self-heating solid, toxic, inorganic, n.o.s.*	3191	4.2	6.1	Spontaneous combustion & Toxic		A3	II III	E2 E1	466 468	15 kg 25 kg	470 471	50 kg 100 kg
Self-heating solid, toxic, organic, n.o.s.*	3128	4.2	6.1	Spontaneous combustion & Toxic		A3	II III	E2 E1	466 468	15 kg 25 kg	470 471	50 kg 100 kg

>

Name	UN No.	Class or division	Subsidiary risk	Labels	State variations	Special provisions	UN packing group	Excepted quantity	Passenger and cargo aircraft		Cargo aircraft only	
									Packing instruction	Max. net quantity per package	Packing instruction	Max. net quantity per package
1	2	3	4	5	6	7	8	9	10	11	12	13
Self-propelled vehicle, see Battery-powered equipment or Battery-powered vehicle or Vehicle, (flammable gas powered) or Vehicle, (flammable liquid powered)												
Self-reactive liquid type B*	3221	4.1							FORBIDDEN		FORBIDDEN	
Self-reactive liquid type B, temperature controlled*	3231	4.1							FORBIDDEN		FORBIDDEN	
Self-reactive liquid type C*	3223	4.1		Solid flammable		A20		E0	459	5 L	459	10 L
Self-reactive liquid type C, temperature controlled*	3233	4.1							FORBIDDEN		FORBIDDEN	
Self-reactive liquid type D*	3225	4.1		Solid flammable		A20		E0	459	5 L	459	10 L
Self-reactive liquid type D, temperature controlled*	3235	4.1							FORBIDDEN		FORBIDDEN	
Self-reactive liquid type E*	3227	4.1		Solid flammable		A20		E0	459	10 L	459	25 L
Self-reactive liquid type E, temperature controlled*	3237	4.1							FORBIDDEN		FORBIDDEN	
Self-reactive liquid type F*	3229	4.1		Solid flammable		A20		E0	459	10 L	459	25 L
Self-reactive liquid type F, temperature controlled*	3239	4.1							FORBIDDEN		FORBIDDEN	
Self-reactive solid type B	FORBIDDEN											
Self-reactive solid type B, temperature controlled	FORBIDDEN											
Self-reactive solid type C*	3224	4.1		Solid flammable		A20		E0	459	5 kg	459	10 kg
Self-reactive solid type C, temperature controlled*	3234	4.1							FORBIDDEN		FORBIDDEN	
Self-reactive solid type D*	3226	4.1		Solid flammable		A20		E0	459	5 kg	459	10 kg
Self-reactive solid type D, temperature controlled*	3236	4.1							FORBIDDEN		FORBIDDEN	
Self-reactive solid type E*	3228	4.1		Solid flammable		A20		E0	459	10 kg	459	25 kg
Self-reactive solid type E, temperature controlled*	3238	4.1							FORBIDDEN		FORBIDDEN	
Self-reactive solid type F*	3230	4.1		Solid flammable		A20		E0	459	10 kg	459	25 kg
Self-reactive solid type F, temperature controlled*	3240	4.1							FORBIDDEN		FORBIDDEN	

Name	UN No.	Class or division	Subsidiary risk	Labels	State variations	Special provisions	UN packing group	Excepted quantity	Passenger and cargo aircraft		Cargo aircraft only	
									Packing instruction	Max. net quantity per package	Packing instruction	Max. net quantity per package
1	2	3	4	5	6	7	8	9	10	11	12	13
Shale oil	1288	3		Liquid flammable		A3	II	E2	353 Y341	5 L 1 L	364	60 L
							III	E1	355 Y344	60 L 10 L	366	220 L
Shaped charges, see Charges, shaped (UN Nos. 0059, 0439, 0440, 0441)												
Signal devices, hand †	0191	1.4G		Explosive 1.4				E0	FORBIDDEN		135	75 kg
Signal devices, hand †	0373	1.4S		Explosive 1.4				E0	135	25 kg	135	100 kg
Signals, distress, ship †	0194	1.1G							FORBIDDEN		FORBIDDEN	
Signals, distress, ship †	0195	1.3G		Explosive				E0	FORBIDDEN		135	75 kg
Signals, distress, ship†	0505	1.4G		Explosive 1.4				E0	FORBIDDEN		135	75 kg
Signals, distress, ship†	0506	1.4S		Explosive 1.4				E0	135	25 kg	135	100 kg
Signals, distress, ship, water-activated, see Contrivances, water-activated , etc.												
Signals, railway track, explosive †	0192	1.1G							FORBIDDEN		FORBIDDEN	
Signals, railway track, explosive †	0193	1.4S		Explosive 1.4				E0	135	25 kg	135	100 kg
Signals, railway track, explosive †	0492	1.3G							FORBIDDEN		FORBIDDEN	
Signals, railway track, explosive †	0493	1.4G		Explosive 1.4				E0	FORBIDDEN		135	75 kg
Signals, smoke †	0196	1.1G							FORBIDDEN		FORBIDDEN	
Signals, smoke †	0197	1.4G		Explosive 1.4				E0	FORBIDDEN		135	75 kg
Signals, smoke †	0313	1.2G							FORBIDDEN		FORBIDDEN	
Signals, smoke †	0487	1.3G							FORBIDDEN		FORBIDDEN	
Signals, smoke †	0507	1.4S		Explosive 1.4				E0	135	25 kg	135	100 kg
Silane	2203	2.1			AU 1 CA 7 IR 3 NL 1 US 3	A2			FORBIDDEN		FORBIDDEN	
Silicofluoric acid, see Fluorosilicic acid												
Silicofluorides, n.o.s., see Fluorosilicates, n.o.s.												

Name	UN No.	Class or division	Subsidiary risk	Labels	State variations	Special provisions	UN packing group	Excepted quantity	Passenger and cargo aircraft		Cargo aircraft only	
									Packing instruction	Max. net quantity per package	Packing instruction	Max. net quantity per package
1	2	3	4	5	6	7	8	9	10	11	12	13
Silicon chloride, see Silicon tetrachloride												
Silicon powder, amorphous	1346	4.1		Solid flammable		A54	III	E1	446 Y443	25 kg 10 kg	449	100 kg
Silicon tetrachloride	1818	8		Corrosive	AU 1 CA 7 IR 3 NL 1 US 3	A1	II	E0	FORBIDDEN		876	30 L
Silicon tetrafluoride	1859	2.3	8		AU 1 CA 7 IR 3 NL 1 US 3	A2			FORBIDDEN		FORBIDDEN	
+ Silicon tetrafluoride, adsorbed	3521	2.3	8			A2		E0	FORBIDDEN		FORBIDDEN	
Silver acetylide (dry)	FORBIDDEN											
Silver arsenite	1683	6.1		Toxic			II	E4	669 Y644	25 kg 1 kg	676	100 kg
Silver azide (dry)	FORBIDDEN											
Silver chlorite (dry)	FORBIDDEN											
Silver cyanide	1684	6.1		Toxic	US 4		II	E4	669 Y644	25 kg 1 kg	676	100 kg
Silver fulminate (dry)	FORBIDDEN											
Silver nitrate	1493	5.1		Oxidizer	US 4		II	E2	558 Y544	5 kg 2.5 kg	562	25 kg
Silver oxalate (dry)	FORBIDDEN											
Silver picrate (dry)	FORBIDDEN											
Silver picrate, wetted with not less than 30% water, by mass	1347	4.1			BE 3	A40			FORBIDDEN		FORBIDDEN	
Sludge acid †	1906	8		Corrosive	AU 1 CA 7 IR 3 NL 1 US 3	A1	II	E0	FORBIDDEN		855	30 L
Soda lime with more than 4% sodium hydroxide †	1907	8		Corrosive		A16	III	E1	860 Y845	25 kg 5 kg	864	100 kg

Name	UN No.	Class or division	Subsidiary risk	Labels	State variations	Special provisions	UN packing group	Excepted quantity	Passenger and cargo aircraft		Cargo aircraft only	
									Packing instruction	Max. net quantity per package	Packing instruction	Max. net quantity per package
1	2	3	4	5	6	7	8	9	10	11	12	13
Sodium	1428	4.3		Danger if wet	AU 1 CA 7 IR 3 NL 1 US 3 US 4	A1	I	E0	FORBIDDEN		487	15 kg
Sodium aluminate, solid	2812	8		Corrosive			III	E1	860 Y845	25 kg 5 kg	864	100 kg
Sodium aluminate solution	1819	8		Corrosive		A3	II	E2	851 Y840	1 L 0.5 L	855	30 L
							III	E1	852 Y841	5 L 1 L	856	60 L
Sodium aluminium hydride	2835	4.3		Danger if wet	AU 1 CA 7 IR 3 NL 1 US 3	A1	II	E0	FORBIDDEN		489	50 kg
Sodium ammonium vanadate	2863	6.1		Toxic			II	E4	669 Y644	25 kg 1 kg	676	100 kg
Sodium arsanilate	2473	6.1		Toxic			III	E1	670 Y645	100 kg 10 kg	677	200 kg
Sodium arsenate	1685	6.1		Toxic	US 4		II	E4	669 Y644	25 kg 1 kg	676	100 kg
Sodium arsenite, aqueous solution	1686	6.1		Toxic	US 4	A3 A6	II	E4	654 Y641	5 L 1 L	662	60 L
							III	E1	655 Y642	60 L 2 L	663	220 L
Sodium arsenite, solid	2027	6.1		Toxic	US 4	A6	II	E4	669 Y644	25 kg 1 kg	676	100 kg
Sodium azide	1687	6.1		Toxic			II	E4	669 Y644	25 kg 1 kg	676	100 kg
Sodium bifluoride, see Sodium hydrogendifluoride												
Sodium binoxide, see Sodium peroxide												
Sodium bisulphite solution, see Bisulphites, aqueous solution, n.o.s.												
Sodium borohydride	1426	4.3		Danger if wet			I	E0	FORBIDDEN		487	15 kg

Name	UN No.	Class or division	Subsidiary risk	Labels	State variations	Special provisions	UN packing group	Excepted quantity	Passenger and cargo aircraft		Cargo aircraft only		
									Packing instruction	Max. net quantity per package	Packing instruction	Max. net quantity per package	
1	2	3	4	5	6	7	8	9	10	11	12	13	
Sodium borohydride and sodium hydroxide solution , with not more than 12% sodium borohydride and not more than 40% sodium hydroxide, by mass	3320	8		Corrosive		A3	II	E2	851	1 L	855	30 L	
									Y840	0.5 L		856	60 L
									852	5 L			
							III	E1	Y841	1 L			
Sodium bromate	1494	5.1		Oxidizer			II	E2	558 Y544	5 kg 2.5 kg	562	25 kg	
Sodium cacodylate	1688	6.1		Toxic			II	E4	669 Y644	25 kg 1 kg	676	100 kg	
Sodium carbonate peroxyhydrate	3378	5.1		Oxidizer			II	E2	558	5 kg	562	25 kg	
									Y544	2.5 kg		563	100 kg
									559	25 kg			
							III	E1	Y546	10 kg			
Sodium chlorate	1495	5.1		Oxidizer			II	E2	558 Y544	5 kg 2.5 kg	562	25 kg	
Sodium chlorate, aqueous solution	2428	5.1		Oxidizer		A3	II	E2	550	1 L	554	5 L	
									Y540	0.5 L		555	30 L
									551	2.5 L			
							III	E1	Y541	1 L			
Sodium chlorate mixed with dinitrotoluene, see Explosive, blasting, type C													
Sodium chlorite	1496	5.1		Oxidizer			II	E2	558 Y544	5 kg 2.5 kg	562	25 kg	
Sodium chloroacetate	2659	6.1		Toxic			III	E1	670 Y645	100 kg 10 kg	677	200 kg	
Sodium cuprocyanide, solid	2316	6.1		Toxic			I	E5	666	5 kg	673	50 kg	
Sodium cuprocyanide solution	2317	6.1		Toxic			I	E5	652	1 L	658	30 L	
Sodium cyanide, solid	1689	6.1		Toxic	US 4		I	E5	666	5 kg	673	50 kg	
Sodium cyanide solution	3414	6.1		Toxic		A3	I	E5	652	1 L	658	30 L	
									654	5 L		662	60 L
									Y641	1 L			
									655	60 L			
							III	E1	Y642	2 L	663	220 L	
Sodium dicyanocuprate, (I), solid, see Sodium cuprocyanide, solid													
Sodium dicyanocuprate, (I), solution, see Sodium cuprocyanide solution													

Name	UN No.	Class or division	Subsidiary risk	Labels	State variations	Special provisions	UN packing group	Excepted quantity	Passenger and cargo aircraft		Cargo aircraft only	
									Packing instruction	Max. net quantity per package	Packing instruction	Max. net quantity per package
1	2	3	4	5	6	7	8	9	10	11	12	13
Sodium dimethylarsenate, see Sodium cacodylate												
Sodium dinitro-o-cresolate , dry or wetted with less than 15% water, by mass	0234	1.3C							FORBIDDEN		FORBIDDEN	
Sodium dinitro-o-cresolate, wetted with not less than 15% water, by mass	1348	4.1	6.1	Solid flammable & Toxic	BE 3	A40	I	E0	451	1 kg	451	15 kg
Sodium dinitro-o-cresolate, wetted with not less than 10% water, by mass	3369	4.1		Solid flammable	BE 3	A40	I	E0	451	0.5 kg	451	0.5 kg
Sodium dioxide, see Sodium peroxide												
Sodium dithionite	1384	4.2		Spontaneous combustion			II	E2	467	15 kg	470	50 kg
Sodium fluoride, solid	1690	6.1		Toxic			III	E1	670 Y645	100 kg 10 kg	677	200 kg
Sodium fluoride solution	3415	6.1		Toxic		A3	III	E1	655 Y642	60 L 2 L	663	220 L
Sodium fluoroacetate	2629	6.1		Toxic	US 4		I	E5	666	5 kg	673	50 kg
Sodium fluorosilicate	2674	6.1		Toxic			III	E1	670 Y645	100 kg 10 kg	677	200 kg
Sodium hexafluorosilicate, see Sodium fluorosilicate												
Sodium hydrate, see Sodium hydroxide solution												
Sodium hydride	1427	4.3		Danger if wet			I	E0	FORBIDDEN		487	15 kg
Sodium hydrogen 4-amino-phenylarsenate, see Sodium arsanilate												
Sodium hydrogendifluoride	2439	8		Corrosive	US 4		II	E2	859 Y844	15 kg 5 kg	863	50 kg
Sodium hydrosulphide with less than 25% water of crystallization	2318	4.2		Spontaneous combustion			II	E2	467	15 kg	470	50 kg
Sodium hydrosulphide, hydrated with not less than 25% water of crystallization	2949	8		Corrosive			II	E2	859 Y844	15 kg 5 kg	863	50 kg
Sodium hydrosulphite	1384	4.2		Spontaneous combustion			II	E2	467	15 kg	470	50 kg
Sodium hydroxide, solid	1823	8		Corrosive			II	E2	859 Y844	15 kg 5 kg	863	50 kg

Name	UN No.	Class or division	Subsidiary risk	Labels	State variations	Special provisions	UN packing group	Excepted quantity	Passenger and cargo aircraft		Cargo aircraft only	
									Packing instruction	Max. net quantity per package	Packing instruction	Max. net quantity per package
1	2	3	4	5	6	7	8	9	10	11	12	13
Sodium hydroxide solution	1824	8		Corrosive		A3	II	E2	851 Y840	1 L 0.5 L	855	30 L
Sodium metasilicate pentahydrate, see Disodium trioxosilicate							III	E1	852 Y841	5 L 1 L	856	60 L
Sodium methylate	1431	4.2	8	Spontaneous combustion & Corrosive			II	E2	466	15 kg	470	50 kg
Sodium methylate solution in alcohol	1289	3	8	Liquid flammable & Corrosive		A3	II	E2	352 Y340	1 L 0.5 L	363	5 L
							III	E1	354 Y342	5 L 1 L	365	60 L
Sodium monoxide	1825	8		Corrosive			II	E2	859 Y844	15 kg 5 kg	863	50 kg
Sodium nitrate	1498	5.1		Oxidizer			III	E1	559 Y546	25 kg 10 kg	563	100 kg
Sodium nitrate and potassium nitrate mixture	1499	5.1		Oxidizer			III	E1	559 Y546	25 kg 10 kg	563	100 kg
Sodium nitrite	1500	5.1	6.1	Oxidizer & Toxic	US 4		III	E1	559 Y546	25 kg 10 kg	563	100 kg
Sodium nitrite and potassium nitrate mixture, see Potassium nitrate and sodium nitrite mixture												
Sodium pentachlorophenate	2567	6.1		Toxic			II	E4	669 Y644	25 kg 1 kg	676	100 kg
Sodium perborate monohydrate	3377	5.1		Oxidizer			III	E1	559 Y546	25 kg 10 kg	563	100 kg
Sodium perchlorate	1502	5.1		Oxidizer			II	E2	558 Y544	5 kg 2.5 kg	562	25 kg
Sodium permanganate	1503	5.1		Oxidizer			II	E2	558 Y544	5 kg 2.5 kg	562	25 kg
Sodium peroxide	1504	5.1		Oxidizer	AU 1 CA 7 IR 3 NL 1 US 3	A1	I	E0	FORBIDDEN		561	15 kg
Sodium peroxoborate, anhydrous	3247	5.1		Oxidizer			II	E2	558 Y544	5 kg 2.5 kg	562	25 kg
Sodium persulphate	1505	5.1		Oxidizer			III	E1	559 Y546	25 kg 10 kg	563	100 kg
Sodium phosphide	1432	4.3	6.1	Danger if wet & Toxic			I	E0	FORBIDDEN		487	15 kg

Name	UN No.	Class or division	Subsidiary risk	Labels	State variations	Special provisions	UN packing group	Excepted quantity	Passenger and cargo aircraft		Cargo aircraft only	
									Packing instruction	Max. net quantity per package	Packing instruction	Max. net quantity per package
1	2	3	4	5	6	7	8	9	10	11	12	13
Sodium picramate , dry or wetted with less than 20% water, by mass	0235	1.3C							FORBIDDEN		FORBIDDEN	
Sodium picramate , wetted with not less than 20% water, by mass	1349	4.1		Solid flammable	AU 1 BE 3 CA 7 IR 3 NL 1 US 3	A1 A40	I	E0	FORBIDDEN		451	15 kg
Sodium picryl peroxide		FORBIDDEN										
Sodium potassium alloys, see Potassium sodium alloys, liquid (UN No. 1422) or Potassium sodium alloys, solid (UN No. 3404)												
Sodium selenate, see Selenates												
Sodium selenite, see Selenites												
Sodium silicofluoride, see Sodium fluorosilicate												
Sodium sulphide with less than 30% water of crystallization	1385	4.2		Spontaneous combustion			II	E2	467	15 kg	470	50 kg
Sodium sulphide, anhydrous †	1385	4.2		Spontaneous combustion			II	E2	467	15 kg	470	50 kg
Sodium sulphide, hydrated with not less than 30% water	1849	8		Corrosive			II	E2	859 Y844	15 kg 5 kg	863	50 kg
Sodium superoxide	2547	5.1		Oxidizer	AU 1 CA 7 IR 3 NL 1 US 3	A1	I	E0	FORBIDDEN		561	15 kg
Sodium tetranitride		FORBIDDEN										
Solids containing corrosive liquid, n.o.s.*	3244	8		Corrosive		A77	II	E2	859 Y844	15 kg 5 kg	863	50 kg
Solids containing flammable liquid, n.o.s.*	3175	4.1		Solid flammable		A46	II	E2	445 Y441	15 kg 5 kg	448	50 kg
Solids containing toxic liquid, n.o.s.*	3243	6.1		Toxic		A50	II	E4	669 Y644	25 kg 1 kg	676	100 kg
Solvents, flammable †, n.o.s., see Flammable liquid, n.o.s.												

Name	UN No.	Class or division	Subsidiary risk	Labels	State variations	Special provisions	UN packing group	Excepted quantity	Passenger and cargo aircraft		Cargo aircraft only	
									Packing instruction	Max. net quantity per package	Packing instruction	Max. net quantity per package
1	2	3	4	5	6	7	8	9	10	11	12	13
Solvents, flammable, toxic †, n.o.s., see Flammable liquid, toxic, n.o.s.												
Sounding devices, explosive †	0204	1.2F							FORBIDDEN		FORBIDDEN	
Sounding devices, explosive †	0296	1.1F							FORBIDDEN		FORBIDDEN	
Sounding devices, explosive †	0374	1.1D							FORBIDDEN		FORBIDDEN	
Sounding devices, explosive †	0375	1.2D							FORBIDDEN		FORBIDDEN	
Squibs, see Igniters (UN Nos. 0325, 0454)												
Stannic chloride, anhydrous	1827	8		Corrosive			II	E2	851 Y840	1 L 0.5 L	855	30 L
Stannic chloride pentahydrate	2440	8		Corrosive			III	E1	860 Y845	25 kg 5 kg	864	100 kg
Stannic phosphides	1433	4.3	6.1	Danger if wet & Toxic			I	E0	FORBIDDEN		487	15 kg
Steel swarf, see Ferrous metal, borings, shavings, turnings or cuttings , etc.												
Stibine	2676	2.3	2.1		AU 1 CA 7 IR 3 NL 1 US 3	A2			FORBIDDEN		FORBIDDEN	
Storage batteries, wet, see Batteries, wet , etc.												
+ Straw	1327	4.1				A2 A198			FORBIDDEN		FORBIDDEN	
Strontium alloys, pyrophoric, see Pyrophoric metal, n.o.s. , etc.												
Strontium arsenite	1691	6.1		Toxic			II	E4	669 Y644	25 kg 1 kg	676	100 kg
Strontium chlorate	1506	5.1		Oxidizer			II	E2	558 Y544	5 kg 2.5 kg	562	25 kg
Strontium dioxide, see Strontium peroxide												
Strontium nitrate	1507	5.1		Oxidizer			III	E1	559 Y546	25 kg 10 kg	563	100 kg
Strontium perchlorate	1508	5.1		Oxidizer			II	E2	558 Y544	5 kg 2.5 kg	562	25 kg

Name	UN No.	Class or division	Subsidiary risk	Labels	State variations	Special provisions	UN packing group	Excepted quantity	Passenger and cargo aircraft		Cargo aircraft only	
									Packing instruction	Max. net quantity per package	Packing instruction	Max. net quantity per package
1	2	3	4	5	6	7	8	9	10	11	12	13
Strontium peroxide	1509	5.1		Oxidizer			II	E2	558 Y544	5 kg 2.5 kg	562	25 kg
Strontium phosphide	2013	4.3	6.1	Danger if wet & Toxic			I	E0	FORBIDDEN		487	15 kg
Strychnine	1692	6.1		Toxic	US 4	A5	I	E5	666	5 kg	673	50 kg
Strychnine salts	1692	6.1		Toxic	US 4	A5	I	E5	666	5 kg	673	50 kg
Styphnic acid , dry or wetted with less than 20% water, or mixture of alcohol and water, by mass	0219	1.1D							FORBIDDEN		FORBIDDEN	
Styphnic acid , wetted with not less than 20% water, or mixture of alcohol and water, by mass	0394	1.1D							FORBIDDEN		FORBIDDEN	
Styrene monomer, stabilized	2055	3		Liquid flammable			III	E1	355 Y344	60 L 10 L	366	220 L
Substances, EVI, n.o.s.* †	0482	1.5D							FORBIDDEN		FORBIDDEN	
Substances, explosive, n.o.s.*	0357	1.1L							FORBIDDEN		FORBIDDEN	
Substances, explosive, n.o.s.*	0358	1.2L							FORBIDDEN		FORBIDDEN	
Substances, explosive, n.o.s.*	0359	1.3L							FORBIDDEN		FORBIDDEN	
Substances, explosive, n.o.s.*	0473	1.1A							FORBIDDEN		FORBIDDEN	
Substances, explosive, n.o.s.*	0474	1.1C							FORBIDDEN		FORBIDDEN	
Substances, explosive, n.o.s.*	0475	1.1D							FORBIDDEN		FORBIDDEN	
Substances, explosive, n.o.s.*	0476	1.1G							FORBIDDEN		FORBIDDEN	
Substances, explosive, n.o.s.*	0477	1.3C							FORBIDDEN		FORBIDDEN	
Substances, explosive, n.o.s.*	0478	1.3G							FORBIDDEN		FORBIDDEN	
Substances, explosive, n.o.s.*	0479	1.4C		Explosive 1.4		A62		E0	FORBIDDEN		101	75 kg
Substances, explosive, n.o.s.*	0480	1.4D		Explosive 1.4		A62		E0	FORBIDDEN		101	75 kg
Substances, explosive, n.o.s.*	0481	1.4S		Explosive 1.4		A62		E0	101	25 kg	101	100 kg
Substances, explosive, n.o.s.*	0485	1.4G		Explosive 1.4		A62		E0	FORBIDDEN		101	75 kg
Substances, explosive, very insensitive, n.o.s.* †	0482	1.5D							FORBIDDEN		FORBIDDEN	
Substances liable to spontaneous combustion, n.o.s., see Pyrophoric liquid/solid, inorganic/organic, n.o.s. or Self-heating liquid/solid, inorganic/organic, n.o.s.												

Name	UN No.	Class or division	Subsidiary risk	Labels	State variations	Special provisions	UN packing group	Excepted quantity	Passenger and cargo aircraft		Cargo aircraft only	
									Packing instruction	Max. net quantity per package	Packing instruction	Max. net quantity per package
1	2	3	4	5	6	7	8	9	10	11	12	13
Substituted nitrophenol pesticide, liquid, flammable, toxic* , flash point less than 23°C	2780	3	6.1	Liquid flammable & Toxic		A4	I	E0	FORBIDDEN		361	30 L
								II	E2	352 Y341	1 L 1 L	364
Substituted nitrophenol pesticide, liquid, toxic*	3014	6.1		Toxic		A3 A4	I	E5	652	1 L	658	30 L
							II	E4	654 Y641	5 L 1 L	662	60 L
							III	E1	655 Y642	60 L 2 L	663	220 L
Substituted nitrophenol pesticide, liquid, toxic, flammable* , flash point not less than 23°C	3013	6.1	3	Toxic & Liquid flammable		A3 A4	I	E5	652	1 L	658	30 L
							II	E4	654 Y641	5 L 1 L	662	60 L
							III	E1	655 Y642	60 L 2 L	663	220 L
Substituted nitrophenol pesticide, solid, toxic*	2779	6.1		Toxic		A3 A5	I	E5	666	5 kg	673	50 kg
							II	E4	669 Y644	25 kg 1 kg	676	100 kg
							III	E1	670 Y645	100 kg 10 kg	677	200 kg
Sucrose octanitrate (dry)									FORBIDDEN			
Sulphamic acid	2967	8		Corrosive			III	E1	860 Y845	25 kg 5 kg	864	100 kg
Sulphur	1350	4.1		Solid flammable		A105	III	E1	446 Y443	25 kg 10 kg	449	100 kg
Sulphur chlorides	1828	8		Corrosive	AU 1 CA 7 IR 3 NL 1 US 3	A1	I	E0	FORBIDDEN		854	2.5 L
Sulphur dichloride, see Sulphur chlorides												
Sulphur dioxide	1079	2.3	8		AU 1 CA 7 IR 3 NL 1 US 3	A2			FORBIDDEN		FORBIDDEN	
Sulphuretted hydrogen, see Hydrogen sulphide (UN No. 1053)												
Sulphur hexafluoride	1080	2.2		Gas non-flammable				E1	200	75 kg	200	150 kg
Sulphuric acid with more than 51% acid	1830	8		Corrosive			II	E2	851 Y840	1 L 0.5 L	855	30 L

Name	UN No.	Class or division	Subsidiary risk	Labels	State variations	Special provisions	UN packing group	Excepted quantity	Passenger and cargo aircraft		Cargo aircraft only	
									Packing instruction	Max. net quantity per package	Packing instruction	Max. net quantity per package
1	2	3	4	5	6	7	8	9	10	11	12	13
Sulphuric acid with not more than 51% acid	2796	8		Corrosive			II	E2	851 Y840	1 L 0.5 L	855	30 L
Sulphuric acid, fuming †	1831	8	6.1		AU 1 CA 7 IR 3 NL 1 US 3	A2			FORBIDDEN		FORBIDDEN	
Sulphuric acid, spent †	1832	8		Corrosive	AU 1 CA 7 IR 3 NL 1 US 3	A1 A34	II	E0	FORBIDDEN		855	30 L
Sulphuric and hydrofluoric acid mixture, see Hydrofluoric acid and sulphuric acid mixture												
Sulphur, molten	2448	4.1							FORBIDDEN		FORBIDDEN	
Sulphur monochloride, see Sulphur chlorides												
Sulphurous acid	1833	8		Corrosive			II	E2	851 Y840	1 L 0.5 L	855	30 L
Sulphur tetrafluoride	2418	2.3	8		AU 1 CA 7 IR 3 NL 1 US 3	A2			FORBIDDEN		FORBIDDEN	
Sulphur trioxide, stabilized	1829	8			AU 1 CA 7 IR 3 NL 1 US 3	A2			FORBIDDEN		FORBIDDEN	
Sulphuryl chloride	1834	6.1	8						FORBIDDEN		FORBIDDEN	
Sulphuryl fluoride	2191	2.3			AU 1 CA 7 IR 3 NL 1 US 3	A2			FORBIDDEN		FORBIDDEN	

T

‡ Talcum with tremolite and/or actinolite, see **Asbestos, amphibole** (UN No. 2212)

Name	UN No.	Class or division	Subsidiary risk	Labels	State variations	Special provisions	UN packing group	Excepted quantity	Passenger and cargo aircraft		Cargo aircraft only	
									Packing instruction	Max. net quantity per package	Packing instruction	Max. net quantity per package
1	2	3	4	5	6	7	8	9	10	11	12	13
Tars, liquid , including road oils, and cutback bitumens	1999	3		Liquid flammable		A3	II	E2	353 Y341	5 L 1 L	364	60 L
							III	E1	355 Y344	60 L 10 L	366	220 L
Tartar emetic, see Antimony potassium tartrate												
# Tear gas candles	1700	6.1	4.1	Toxic & Solid flammable	AU 1 CA 7 IR 3 NL 1 US 3	A1		E0	FORBIDDEN		679	50 kg
Tear gas cartridges, see Ammunition, tear-producing , etc.												
Tear gas devices, containing tear gas substances, see Aerosols etc.												
Tear gas grenades, see Tear gas candles												
Tear gas substance, liquid, n.o.s.*	1693	6.1		Toxic	AU 1 CA 7 IR 3 NL 1 US 3	A2 A36	II	E0	FORBIDDEN FORBIDDEN		FORBIDDEN 659	FORBIDDEN 5 L
Tear gas substance, solid, n.o.s.*	3448	6.1		Toxic	AU 1 CA 7 IR 3 NL 1 US 3	A1 A36	I II	E0 E0	FORBIDDEN FORBIDDEN		672 674	15 kg 25 kg
Tellurium compound, n.o.s.*	3284	6.1		Toxic		A3 A5	I II	E5 E4	666 669 Y644	5 kg 25 kg 1 kg	673 676	50 kg 100 kg
							III	E1	670 Y645	100 kg 10 kg	677	200 kg
Tellurium hexafluoride	2195	2.3	8		AU 1 CA 7 IR 3 NL 1 US 3	A2			FORBIDDEN		FORBIDDEN	
Terpene hydrocarbons, n.o.s.	2319	3		Liquid flammable			III	E1	355 Y344	60 L 10 L	366	220 L
Terpinolene	2541	3		Liquid flammable			III	E1	355 Y344	60 L 10 L	366	220 L
Tetraazido benzene quinone	FORBIDDEN											

Name	UN No.	Class or division	Subsidiary risk	Labels	State variations	Special provisions	UN packing group	Excepted quantity	Passenger and cargo aircraft		Cargo aircraft only	
									Packing instruction	Max. net quantity per package	Packing instruction	Max. net quantity per package
1	2	3	4	5	6	7	8	9	10	11	12	13
Tetrabromoethane	2504	6.1		Toxic			III	E1	655 Y642	60 L 2 L	663	220 L
1,1,2,2-Tetrachloroethane	1702	6.1		Toxic	US 4		II	E4	654 Y641	5 L 1 L	661	60 L
Tetrachloroethylene	1897	6.1		Toxic	US 4		III	E1	655 Y642	60 L 2 L	663	220 L
Tetraethylammonium perchlorate (dry)	FORBIDDEN											
Tetraethyl dithiopyrophosphate	1704	6.1		Toxic	US 4	A6	II	E4	654 Y641	5 L 1 L	662	60 L
Tetraethylenepentamine	2320	8		Corrosive			III	E1	852 Y841	5 L 1 L	856	60 L
Tetraethyl lead, see Motor fuel anti-knock mixture												
Tetraethyloxysilane, see Tetraethyl silicate												
Tetraethyl silicate	1292	3		Liquid flammable			III	E1	355 Y344	60 L 10 L	366	220 L
Tetrafluorodichloroethane, see 1,2-Dichloro-1,1,2,2-tetrafluoroethane or Refrigerant gas R 114 (UN No. 1958)												
1,1,1,2-Tetrafluoroethane	3159	2.2		Gas non-flammable				E1	200	75 kg	200	150 kg
Tetrafluoroethylene, stabilized	1081	2.1		Gas flammable	AU 1 CA 7 IR 3 NL 1 US 3	A1		E0	FORBIDDEN		200	150 kg
Tetrafluoromethane	1982	2.2		Gas non-flammable				E1	200	75 kg	200	150 kg
1,2,3,6-Tetrahydrobenzaldehyde	2498	3		Liquid flammable			III	E1	355 Y344	60 L 10 L	366	220 L
Tetrahydrofuran	2056	3		Liquid flammable			II	E2	353 Y341	5 L 1 L	364	60 L
Tetrahydrofurfurylamine	2943	3		Liquid flammable			III	E1	355 Y344	60 L 10 L	366	220 L
Tetrahydro-1,4-oxazine, see Morpholine												
Tetrahydrophthalic anhydrides with more than 0.05% of maleic anhydride	2698	8		Corrosive		A74	III	E1	860 Y845	25 kg 5 kg	864	100 kg
1,2,3,6-Tetrahydropyridine	2410	3		Liquid flammable			II	E2	353 Y341	5 L 1 L	364	60 L

Name	UN No.	Class or division	Subsidiary risk	Labels	State variations	Special provisions	UN packing group	Excepted quantity	Passenger and cargo aircraft		Cargo aircraft only	
									Packing instruction	Max. net quantity per package	Packing instruction	Max. net quantity per package
1	2	3	4	5	6	7	8	9	10	11	12	13
Tetrahydrothiophene	2412	3		Liquid flammable			II	E2	353 Y341	5 L 1 L	364	60 L
Tetramethoxysilane, see Methyl orthosilicate												
Tetramethylammonium hydroxide, solid	3423	8		Corrosive			II	E2	859 Y844	15 kg 5 kg	863	50 kg
Tetramethylammonium hydroxide solution	1835	8		Corrosive		A3	II	E2	851 Y840	1 L 0.5 L	855	30 L
							III	E1	852 Y841	5 L 1 L	856	60 L
Tetramethylene, see Cyclobutane												
Tetramethylene cyanide, see Adiponitrile												
Tetramethylene diperoxide dicarbamide	FORBIDDEN											
Tetramethyl lead, see Motor fuel anti-knock mixture												
Tetramethylsilane	2749	3		Liquid flammable	AU 1 CA 7 IR 3 NL 1 US 3	A1	I	E0	FORBIDDEN		361	30 L
Tetranitroaniline	0207	1.1D							FORBIDDEN		FORBIDDEN	
Tetranitro diglycerin	FORBIDDEN											
Tetranitromethane	1510	6.1	5.1						FORBIDDEN		FORBIDDEN	
2,3,4,6-Tetranitrophenol	FORBIDDEN											
2,3,4,6-Tetranitrophenyl methyl nitramine	FORBIDDEN											
2,3,4,6-Tetranitrophenylnitramine	FORBIDDEN											
Tetranitroresorcinol (dry)	FORBIDDEN											
2,3,5,6-Tetranitroso- 1,4-dinitrobenzene	FORBIDDEN											

Name	UN No.	Class or division	Subsidiary risk	Labels	State variations	Special provisions	UN packing group	Excepted quantity	Passenger and cargo aircraft		Cargo aircraft only	
									Packing instruction	Max. net quantity per package	Packing instruction	Max. net quantity per package
1	2	3	4	5	6	7	8	9	10	11	12	13
2,3,5,6-Tetranitroso nitrobenzene (dry)	FORBIDDEN											
Tetrapropyl orthotitanate	2413	3		Liquid flammable			III	E1	355 Y344	60 L 10 L	366	220 L
Tetrazene (dry)	FORBIDDEN											
Tetrazene, wetted with not less than 30% water, or mixture of alcohol and water, by mass	0114	1.1A							FORBIDDEN		FORBIDDEN	
Tetrazine	FORBIDDEN											
Tetrazol-1-acetic acid	0407	1.4C		Explosive 1.4				E0	FORBIDDEN		114 b)	75 kg
1H-Tetrazole	0504	1.1D							FORBIDDEN		FORBIDDEN	
Tetrazolyl azide (dry)	FORBIDDEN											
Tetryl	0208	1.1D							FORBIDDEN		FORBIDDEN	
+ Textile waste, wet	1857	4.2				A2			FORBIDDEN		FORBIDDEN	
Thallium chlorate	2573	5.1	6.1	Oxidizer & Toxic			II	E2	558 Y543	5 kg 1 kg	562	25 kg
Thallium (I) chlorate, see Thallium chlorate												
Thallium compound, n.o.s.*	1707	6.1		Toxic	US 4	A6	II	E4	669 Y644	25 kg 1 kg	676	100 kg
Thallium nitrate	2727	6.1	5.1	Toxic & Oxidizer			II	E4	667 Y644	5 kg 1 kg	674	25 kg
Thallium (I) nitrate, see Thallium nitrate												
Thallos chlorate, see Thallium chlorate												
4-Thiapentanal	2785	6.1		Toxic			III	E1	655 Y642	60 L 2 L	663	220 L
Thia-4-pentanal, see 4-Thiapentanal												
Thioacetic acid	2436	3		Liquid flammable			II	E2	353 Y341	5 L 1 L	364	60 L
Thiocarbamate pesticide, liquid, flammable, toxic* , flash point less than 23°C	2772	3	6.1	Liquid flammable & Toxic		A4	I II	E0 E2	FORBIDDEN 352 Y341	1 L 1 L	361 364	30 L 60 L

Name	UN No.	Class or division	Subsidiary risk	Labels	State variations	Special provisions	UN packing group	Excepted quantity	Passenger and cargo aircraft		Cargo aircraft only	
									Packing instruction	Max. net quantity per package	Packing instruction	Max. net quantity per package
1	2	3	4	5	6	7	8	9	10	11	12	13
Thiocarbamate pesticide, liquid, toxic*	3006	6.1		Toxic		A3 A4	I II	E5 E4	652	1 L	658	30 L
									654	5 L	662	60 L
									Y641 655 Y642	1 L 60 L 2 L	663	220 L
Thiocarbamate pesticide, liquid, toxic, flammable* , flash point not less than 23°C	3005	6.1	3	Toxic & Liquid flammable		A3 A4	I II	E5 E4	652	1 L	658	30 L
									654	5 L	662	60 L
									Y641 655 Y642	1 L 60 L 2 L	663	220 L
Thiocarbamate pesticide, solid, toxic*	2771	6.1		Toxic		A3 A5	I II	E5 E4	666	5 kg	673	50 kg
									669	25 kg	676	100 kg
									Y644 670 Y645	1 kg 100 kg 10 kg	677	200 kg
Thioglycol	2966	6.1		Toxic			II	E4	654 Y641	5 L 1 L	662	60 L
Thioglycolic acid	1940	8		Corrosive			II	E2	851 Y840	1 L 0.5 L	855	30 L
Thiolactic acid	2936	6.1		Toxic			II	E4	654 Y641	5 L 1 L	662	60 L
Thionyl chloride	1836	8			AU 1 CA 7 IR 3 NL 1 US 3	A2			FORBIDDEN		FORBIDDEN	
Thiophene	2414	3		Liquid flammable			II	E2	353 Y341	5 L 1 L	364	60 L
Thiophenol, see Phenyl mercaptan												
Thiophosgene	2474	6.1			AU 1 CA 7 IR 3 NL 1 US 3	A2			FORBIDDEN		FORBIDDEN	
Thiophosphoryl chloride	1837	8		Corrosive	AU 1 CA 7 IR 3 NL 1 US 3	A1	II	E0	FORBIDDEN		855	30 L
Thiourea dioxide	3341	4.2		Spontaneous combustion		A3	II III	E2 E1	467	15 kg	470	50 kg
									469	25 kg	471	100 kg
Tin chloride anhydrous, see Stannic chloride, anhydrous												

Name	UN No.	Class or division	Subsidiary risk	Labels	State variations	Special provisions	UN packing group	Excepted quantity	Passenger and cargo aircraft		Cargo aircraft only	
									Packing instruction	Max. net quantity per package	Packing instruction	Max. net quantity per package
1	2	3	4	5	6	7	8	9	10	11	12	13
Tin (IV) chloride, anhydrous, see Stannic chloride, anhydrous												
Tin chloride pentahydrate, see Stannic chloride pentahydrate												
Tin (IV) chloride pentahydrate, see Stannic chloride pentahydrate												
Tinctures, medicinal	1293	3		Liquid flammable		A3	II	E2	353 Y341	5 L 1 L	364	60 L
							III	E1	355 Y344	60 L 10 L	366	220 L
Tin tetrachloride, see Stannic chloride, anhydrous												
Tire assemblies inflated, unserviceable, damaged or above maximum rated pressure	—	2.2				A59			FORBIDDEN		FORBIDDEN	
Titanium disulphide	3174	4.2		Spontaneous combustion			III	E1	469	25 kg	471	100 kg
Titanium hydride	1871	4.1		Solid flammable			II	E2	445 Y441	15 kg 5 kg	448	50 kg
Titanium powder, dry	2546	4.2		Spontaneous combustion		A3	II	E2	FORBIDDEN		FORBIDDEN	
							III	E1	467	15 kg	470	50 kg
									469	25 kg	471	100 kg
Titanium powder, wetted with not less than 25% water (a visible excess of water must be present) (a) mechanically produced, particle size less than 53 microns; (b) chemically produced, particle size less than 840 microns	1352	4.1		Solid flammable		A35	II	E2	445 Y441	15 kg 5 kg	448	50 kg
Titanium sponge granules	2878	4.1		Solid flammable		A3	III	E1	446 Y443	25 kg 10 kg	449	100 kg
Titanium sponge powders	2878	4.1		Solid flammable		A3	III	E1	446 Y443	25 kg 10 kg	449	100 kg
Titanium sulphate solution with not more than 45% sulphuric acid, see Corrosive liquid, acidic, inorganic, n.o.s.												
Titanium tetrachloride	1838	6.1	8		AU 1 CA 7 IR 3 NL 1 US 3	A2			FORBIDDEN		FORBIDDEN	

Name	UN No.	Class or division	Subsidiary risk	Labels	State variations	Special provisions	UN packing group	Excepted quantity	Passenger and cargo aircraft		Cargo aircraft only	
									Packing instruction	Max. net quantity per package	Packing instruction	Max. net quantity per package
1	2	3	4	5	6	7	8	9	10	11	12	13
Titanium trichloride mixture	2869	8		Corrosive		A3	II	E2	859 Y844	15 kg 5 kg	863	50 kg
							III	E1	860 Y845	25 kg 5 kg	864	100 kg
Titanium trichloride mixture, pyrophoric	2441	4.2	8						FORBIDDEN		FORBIDDEN	
Titanium trichloride, pyrophoric	2441	4.2	8						FORBIDDEN		FORBIDDEN	
TNT, dry or wetted with less than 30% water, by mass	0209	1.1D							FORBIDDEN		FORBIDDEN	
TNT and hexanitrostilbene mixture	0388	1.1D							FORBIDDEN		FORBIDDEN	
TNT and trinitrobenzene mixture	0388	1.1D							FORBIDDEN		FORBIDDEN	
TNT mixed with aluminium, see Tritonal												
TNT mixture containing trinitrobenzene and hexanitrostilbene	0389	1.1D							FORBIDDEN		FORBIDDEN	
TNT, wetted with not less than 30% water, by mass	1356	4.1		Solid flammable	BE 3	A40	I	E0	451	0.5 kg	451	0.5 kg
TNT, wetted with not less than 10% water, by mass	3366	4.1		Solid flammable	BE 3	A40	I	E0	451	0.5 kg	451	0.5 kg
Toe puffs, nitrocellulose base, see Fibres impregnated with weakly nitrated nitrocellulose, n.o.s. or Fabrics impregnated with weakly nitrated nitrocellulose, n.o.s.												
Toluene	1294	3		Liquid flammable			II	E2	353 Y341	5 L 1 L	364	60 L
Toluene diisocyanate	2078	6.1		Toxic	US 4	A113	II	E4	654 Y641	5 L 1 L	662	60 L
Toluidines, liquid	1708	6.1		Toxic	US 4	A113	II	E4	654 Y641	5 L 1 L	662	60 L
Toluidines, solid	3451	6.1		Toxic	US 4	A113	II	E4	669 Y644	25 kg 1 kg	676	100 kg
Toluol, see Toluene												
2,4-Toluylenediamine, solid	1709	6.1		Toxic			III	E1	670 Y645	100 kg 10 kg	677	200 kg
2,4-Toluylenediamine solution	3418	6.1		Toxic		A3	III	E1	655 Y642	60 L 2 L	663	220 L
Toluylene diisocyanate, see Toluene diisocyanate												

Name	UN No.	Class or division	Subsidiary risk	Labels	State variations	Special provisions	UN packing group	Excepted quantity	Passenger and cargo aircraft		Cargo aircraft only	
									Packing instruction	Max. net quantity per package	Packing instruction	Max. net quantity per package
Tolyethylene, inhibited, see Vinyltoluenes, stabilized												
Torpedoes with bursting charge †	0329	1.1E							FORBIDDEN		FORBIDDEN	
Torpedoes with bursting charge †	0330	1.1F							FORBIDDEN		FORBIDDEN	
Torpedoes with bursting charge †	0451	1.1D							FORBIDDEN		FORBIDDEN	
Torpedoes, liquid fuelled with inert head †	0450	1.3J							FORBIDDEN		FORBIDDEN	
Torpedoes, liquid fuelled with or without bursting charge †	0449	1.1J							FORBIDDEN		FORBIDDEN	
Toxic by inhalation liquid, n.o.s.* with an LC ₅₀ lower than or equal to 200 mL/m ³ and saturated vapour concentration greater than or equal to 500 LC ₅₀	3381	6.1							FORBIDDEN		FORBIDDEN	
Toxic by inhalation liquid, n.o.s.* with an LC ₅₀ lower than or equal to 1 000 mL/m ³ and saturated vapour concentration greater than or equal to 10 LC ₅₀	3382	6.1							FORBIDDEN		FORBIDDEN	
Toxic by inhalation liquid, corrosive, n.o.s.* with an LC ₅₀ lower than or equal to 200 mL/m ³ and saturated vapour concentration greater than or equal to 500 LC ₅₀	3389	6.1	8						FORBIDDEN		FORBIDDEN	
Toxic by inhalation liquid, corrosive, n.o.s.* with an LC ₅₀ lower than or equal to 1 000 mL/m ³ and saturated vapour concentration greater than or equal to 10 LC ₅₀	3390	6.1	8						FORBIDDEN		FORBIDDEN	
Toxic by inhalation liquid, flammable, n.o.s.* with an LC ₅₀ lower than or equal to 200 mL/m ³ and saturated vapour concentration greater than or equal to 500 LC ₅₀	3383	6.1	3						FORBIDDEN		FORBIDDEN	
Toxic by inhalation liquid, flammable, n.o.s.* with an LC ₅₀ lower than or equal to 1 000 mL/m ³ and saturated vapour concentration greater than or equal to 10 LC ₅₀	3384	6.1	3						FORBIDDEN		FORBIDDEN	
Toxic by inhalation liquid, flammable, corrosive, n.o.s.* with an LC ₅₀ lower than or equal to 200 mL/m ³ and saturated vapour concentration greater than or equal to 500 LC ₅₀	3488	6.1	3 8						FORBIDDEN		FORBIDDEN	

Name	UN No.	Class or division	Subsidiary risk	Labels	State variations	Special provisions	UN packing group	Excepted quantity	Passenger and cargo aircraft		Cargo aircraft only	
									Packing instruction	Max. net quantity per package	Packing instruction	Max. net quantity per package
1	2	3	4	5	6	7	8	9	10	11	12	13
Toxic by inhalation liquid, flammable, corrosive, n.o.s.* with an LC ₅₀ lower than or equal to 1 000 mL/m ³ and saturated vapour concentration greater than or equal to 10 LC ₅₀	3489	6.1	3 8						FORBIDDEN		FORBIDDEN	
Toxic by inhalation liquid, oxidizing, n.o.s.* with an LC ₅₀ lower than or equal to 200 mL/m ³ and saturated vapour concentration greater than or equal to 500 LC ₅₀	3387	6.1	5.1						FORBIDDEN		FORBIDDEN	
Toxic by inhalation liquid, oxidizing, n.o.s.* with an LC ₅₀ lower than or equal to 1 000 mL/m ³ and saturated vapour concentration greater than or equal to 10 LC ₅₀	3388	6.1	5.1						FORBIDDEN		FORBIDDEN	
Toxic by inhalation liquid, water-reactive, n.o.s.* with an LC ₅₀ lower than or equal to 200 mL/m ³ and saturated vapour concentration greater than or equal to 500 LC ₅₀	3385	6.1	4.3						FORBIDDEN		FORBIDDEN	
Toxic by inhalation liquid, water-reactive, n.o.s.* with an LC ₅₀ lower than or equal to 1 000 mL/m ³ and saturated vapour concentration greater than or equal to 10 LC ₅₀	3386	6.1	4.3						FORBIDDEN		FORBIDDEN	
Toxic by inhalation liquid, water-reactive, flammable, n.o.s.* with an LC ₅₀ lower than or equal to 200 mL/m ³ and saturated vapour concentration greater than or equal to 500 LC ₅₀	3490	6.1	3 4.3						FORBIDDEN		FORBIDDEN	
Toxic by inhalation liquid, water-reactive, flammable, n.o.s.* with an LC ₅₀ lower than or equal to 1 000 mL/m ³ and saturated vapour concentration greater than or equal to 10 LC ₅₀	3491	6.1	3 4.3						FORBIDDEN		FORBIDDEN	
Toxic gas, n.o.s., see Compressed or Liquefied gas, toxic , etc.												
Toxic liquid, corrosive, inorganic, n.o.s.*	3289	6.1	8	Toxic & Corrosive		A4 A137	I II	E5 E4	651 653 Y640	0.5 L 1 L 0.5 L	657 660	2.5 L 30 L
Toxic liquid, corrosive, organic, n.o.s.*	2927	6.1	8	Toxic & Corrosive		A4 A137	I II	E5 E4	651 653 Y640	0.5 L 1 L 0.5 L	657 660	2.5 L 30 L
Toxic liquid, flammable, organic, n.o.s.*	2929	6.1	3	Toxic & Liquid flammable		A4 A137	I II	E5 E4	652 654 Y641	1 L 5 L 1 L	658 662	30 L 60 L

Name	UN No.	Class or division	Subsidiary risk	Labels	State variations	Special provisions	UN packing group	Excepted quantity	Passenger and cargo aircraft		Cargo aircraft only	
									Packing instruction	Max. net quantity per package	Packing instruction	Max. net quantity per package
1	2	3	4	5	6	7	8	9	10	11	12	13
Toxic liquid, inorganic, n.o.s.*	3287	6.1		Toxic		A3 A4 A137	I II III	E5 E4 E1	652	1 L	658	30 L
									654	5 L	662	60 L
									Y641	1 L		
									655 Y642	60 L 2 L	663	220 L
Toxic liquid, organic, n.o.s.*	2810	6.1		Toxic		A3 A4 A137	I II III	E5 E4 E1	652	1 L	658	30 L
									654	5 L	662	60 L
									Y641	1 L		
									655 Y642	60 L 2 L	663	220 L
Toxic liquid, oxidizing, n.o.s.*	3122	6.1	5.1	Toxic & Oxidizer		A4 A137	I II	E0 E4	FORBIDDEN		657	2.5 L
									653 Y641	1 L 1 L	659	5 L
Toxic liquid, water-reactive, n.o.s.*	3123	6.1	4.3	Toxic & Danger if wet		A4 A137	I II	E0 E4	FORBIDDEN		699	1 L
									653	1 L	659	5 L
Toxic solid, corrosive, inorganic, n.o.s.*	3290	6.1	8	Toxic & Corrosive		A5	I II	E5 E4	665	1 kg	672	15 kg
									668	15 kg	675	50 kg
									Y644	1 kg		
Toxic solid, corrosive, organic, n.o.s.*	2928	6.1	8	Toxic & Corrosive		A5	I II	E5 E4	665	1 kg	672	15 kg
									668	15 kg	675	50 kg
									Y644	1 kg		
Toxic solid, flammable, organic, n.o.s.*	2930	6.1	4.1	Toxic & Solid flammable		A5	I II	E5 E4	665	1 kg	672	15 kg
									668	15 kg	675	50 kg
									Y644	1 kg		
Toxic solid, inorganic, n.o.s.*	3288	6.1		Toxic		A3 A5	I II III	E5 E4 E1	666	5 kg	673	50 kg
									669	25 kg	676	100 kg
									Y644	1 kg		
									670 Y645	100 kg 10 kg	677	200 kg
Toxic solid, organic, n.o.s.*	2811	6.1		Toxic		A3 A5	I II III	E5 E4 E1	666	5 kg	673	50 kg
									669	25 kg	676	100 kg
									Y644	1 kg		
									670 Y645	100 kg 10 kg	677	200 kg
Toxic solid, oxidizing, n.o.s.*	3086	6.1	5.1	Toxic & Oxidizer		A5	I II	E5 E4	665	1 kg	672	15 kg
									667	5 kg	674	25 kg
									Y644	1 kg		
Toxic solid, self-heating, n.o.s.*	3124	6.1	4.2	Toxic & Spontaneous combustion		A5	I II	E5 E4	665	1 kg	672	15 kg
									668	15 kg	675	50 kg
Toxic solid, water-reactive, n.o.s.*	3125	6.1	4.3	Toxic & Danger if wet		A5	I II	E5 E4	699	5 kg	699	15 kg
									668	15 kg	675	50 kg
									Y644	1 kg		

Name	UN No.	Class or division	Subsidiary risk	Labels	State variations	Special provisions	UN packing group	Excepted quantity	Passenger and cargo aircraft		Cargo aircraft only	
									Packing instruction	Max. net quantity per package	Packing instruction	Max. net quantity per package
1	2	3	4	5	6	7	8	9	10	11	12	13
Toxins, extracted from living sources, liquid, n.o.s.*	3172	6.1		Toxic		A3 A43	I II III	E5 E4 E1	652	1 L	658	30 L
									654	5 L	662	60 L
									Y641	1 L	663	220 L
655	60 L											
									Y642	2 L		
Toxins, extracted from living sources, solid, n.o.s.*	3462	6.1		Toxic		A3 A43	I II III	E5 E4 E1	666	5 kg	673	50 kg
									669	25 kg	676	100 kg
									Y644	1 kg	677	200 kg
670	100 kg											
									Y645	10 kg		
Tracers for ammunition †	0212	1.3G							FORBIDDEN		FORBIDDEN	
Tracers for ammunition †	0306	1.4G		Explosive 1.4				E0	FORBIDDEN		133	75 kg
Tractors, see Vehicle (flammable gas powered) or Vehicle (flammable liquid powered)												
‡ Tremolite, see Asbestos, amphibole (UN No. 2212)												
Triallylamine	2610	3	8	Liquid flammable & Corrosive			III	E1	354 Y342	5 L 1 L	365	60 L
Triallyl borate	2609	6.1		Toxic			III	E1	655 Y642	60 L 2 L	663	220 L
Triazine pesticide, liquid, flammable, toxic* , flash point less than 23°C	2764	3	6.1	Liquid flammable & Toxic		A4	I II	E0 E2	FORBIDDEN		361	30 L
									352	1 L	364	60 L
									Y341	1 L		
Triazine pesticide, liquid, toxic*	2998	6.1		Toxic		A3 A4	I II III	E5 E4 E1	652	1 L	658	30 L
									654	5 L	662	60 L
									Y641	1 L	663	220 L
655	60 L											
									Y642	2 L		
Triazine pesticide, liquid, toxic, flammable* , flash point not less than 23°C	2997	6.1	3	Toxic & Liquid flammable		A3 A4	I II III	E5 E4 E1	652	1 L	658	30 L
									654	5 L	662	60 L
									Y641	1 L	663	220 L
655	60 L											
									Y642	2 L		
Triazine pesticide, solid, toxic*	2763	6.1		Toxic		A3 A5	I II III	E5 E4 E1	666	5 kg	673	50 kg
									669	25 kg	676	100 kg
									Y644	1 kg	677	200 kg
670	100 kg											
									Y645	10 kg		
Tri-(b-nitroxyethyl) ammonium nitrate	FORBIDDEN											

Name	UN No.	Class or division	Subsidiary risk	Labels	State variations	Special provisions	UN packing group	Excepted quantity	Passenger and cargo aircraft		Cargo aircraft only	
									Packing instruction	Max. net quantity per package	Packing instruction	Max. net quantity per package
1	2	3	4	5	6	7	8	9	10	11	12	13
Tribromoborane, see Boron tribromide												
Tributylamine	2542	6.1		Toxic			II	E4	654 Y641	5 L 1 L	662	60 L
Tributylphosphane	3254	4.2							FORBIDDEN		FORBIDDEN	
Trichloroacetaldehyde, see Chloral, anhydrous, stabilized (UN No. 2075)												
Trichloroacetic acid	1839	8		Corrosive			II	E2	859 Y844	15 kg 5 kg	863	50 kg
Trichloroacetic acid solution	2564	8		Corrosive		A3	II	E2	851 Y840	1 L 0.5 L	855	30 L
							III	E1	852 Y841	5 L 1 L	856	60 L
Trichloroacetyl chloride	2442	8			AU 1 CA 7 IR 3 NL 1 US 3	A2			FORBIDDEN		FORBIDDEN	
Trichlorobenzenes, liquid	2321	6.1		Toxic	US 4		III	E1	655 Y642	60 L 2 L	663	220 L
Trichlorobutene	2322	6.1		Toxic			II	E4	654 Y641	5 L 1 L	662	60 L
1,1,1-Trichloroethane	2831	6.1		Toxic			III	E1	655 Y642	60 L 2 L	663	220 L
Trichloroethylene	1710	6.1		Toxic	US 4		III	E1	655 Y642	60 L 2 L	663	220 L
Trichloroisocyanuric acid, dry	2468	5.1		Oxidizer			II	E2	558 Y544	5 kg 2.5 kg	562	25 kg
Trichloromethyl perchlorate	FORBIDDEN											
Trichloronitromethane, see Chloropicrin												
Trichloroacetaldehyde, see Chloral, anhydrous, stabilized (UN No. 2075)												
Trichlorosilane	1295	4.3	3 8						FORBIDDEN		FORBIDDEN	
1,3,5-Trichloro-s-triazine-2,4,6-trione, see Trichloroisocyanuric acid, dry												

Name	UN No.	Class or division	Subsidiary risk	Labels	State variations	Special provisions	UN packing group	Excepted quantity	Passenger and cargo aircraft		Cargo aircraft only	
									Packing instruction	Max. net quantity per package	Packing instruction	Max. net quantity per package
1	2	3	4	5	6	7	8	9	10	11	12	13
2,4,6-Trichloro-1,3,5-triazine, see Cyanuric chloride												
Tricresyl phosphate with more than 3% ortho isomer	2574	6.1		Toxic			II	E4	654 Y641	5 L 1 L	661	60 L
Triethylamine	1296	3	8	Liquid flammable & Corrosive			II	E2	352 Y340	1 L 0.5 L	363	5 L
Triethyl borate, see Ethyl borate												
Triethylenetetramine	2259	8		Corrosive			II	E2	851 Y840	1 L 0.5 L	855	30 L
Triethyl orthoformate, see Ethyl orthoformate												
Triethyl phosphite	2323	3		Liquid flammable			III	E1	355 Y344	60 L 10 L	366	220 L
Trifluoroacetic acid	2699	8		Corrosive			I	E0	850	0.5 L	854	2.5 L
Trifluoroacetyl chloride	3057	2.3	8		AU 1 CA 7 IR 3 NL 1 US 3	A2			FORBIDDEN		FORBIDDEN	
Trifluorobromomethane, see Bromotrifluoromethane												
Trifluorochloroethane, see 1-Chloro-2,2,2-trifluoroethane												
Trifluorochloroethylene, stabilized	1082	2.3	2.1		AU 1 CA 7 IR 3 NL 1 US 3	A2			FORBIDDEN		FORBIDDEN	
Trifluorochloromethane, see Chlorotrifluoromethane												
1,1,1-Trifluoroethane	2035	2.1		Gas flammable	AU 1 CA 7 IR 3 NL 1 US 3	A1		E0	FORBIDDEN		200	150 kg
Trifluoromethane	1984	2.2		Gas non-flammable				E1	200	75 kg	200	150 kg
Trifluoromethane, refrigerated liquid	3136	2.2		Gas non-flammable				E1	202	50 kg	202	500 kg

Name	UN No.	Class or division	Subsidiary risk	Labels	State variations	Special provisions	UN packing group	Excepted quantity	Passenger and cargo aircraft		Cargo aircraft only	
									Packing instruction	Max. net quantity per package	Packing instruction	Max. net quantity per package
1	2	3	4	5	6	7	8	9	10	11	12	13
2-Trifluoromethylaniline	2942	6.1		Toxic			III	E1	655 Y642	60 L 2 L	663	220 L
3-Trifluoromethylaniline	2948	6.1		Toxic			II	E4	654 Y641	5 L 1 L	662	60 L
Triformoxime trinitrate	FORBIDDEN											
Triisobutylene	2324	3		Liquid flammable			III	E1	355 Y344	60 L 10 L	366	220 L
Triisopropyl borate	2616	3		Liquid flammable		A3	II	E2	353 Y341	5 L 1 L	364	60 L
							III	E1	355 Y344	60 L 10 L	366	220 L
Trimethylacetyl chloride	2438	6.1	3 8						FORBIDDEN		FORBIDDEN	
Trimethylamine, anhydrous	1083	2.1		Gas flammable	AU 1 CA 7 IR 3 NL 1 US 3 US 4	A1		E0	FORBIDDEN		200	150 kg
Trimethylamine, aqueous solution , not more than 50% trimethylamine, by mass	1297	3	8	Liquid flammable & Corrosive		A3	I II III	E0 E2 E1	350 352 Y340 354 Y342	0.5 L 1 L 0.5 L 5 L 1 L	360 363 365	2.5 L 5 L 60 L
1,3,5-Trimethylbenzene	2325	3		Liquid flammable			III	E1	355 Y344	60 L 10 L	366	220 L
Trimethyl borate	2416	3		Liquid flammable			II	E2	353 Y341	5 L 1 L	364	60 L
Trimethylchlorosilane	1298	3	8	Liquid flammable & Corrosive			II	E0	FORBIDDEN		377	5 L
Trimethylcyclohexylamine	2326	8		Corrosive			III	E1	852 Y841	5 L 1 L	856	60 L
Trimethylene chlorobromide, see 1-Bromo-3-chloropropane												
Trimethylene glycol diperchlorate	FORBIDDEN											
Trimethylhexamethylenediamines	2327	8		Corrosive			III	E1	852 Y841	5 L 1 L	856	60 L
Trimethylhexamethylene diisocyanate	2328	6.1		Toxic			III	E1	655 Y642	60 L 2 L	663	220 L
Trimethylol nitromethane trinitrate	FORBIDDEN											

Name	UN No.	Class or division	Subsidiary risk	Labels	State variations	Special provisions	UN packing group	Excepted quantity	Passenger and cargo aircraft		Cargo aircraft only	
									Packing instruction	Max. net quantity per package	Packing instruction	Max. net quantity per package
1	2	3	4	5	6	7	8	9	10	11	12	13
2,4,4-Trimethylpentene-1, see Diisobutylene, isomeric compounds (UN No. 2050)												
2,4,4-Trimethylpentene-2, see Diisobutylene, isomeric compounds (UN No. 2050)												
Trimethyl phosphite	2329	3		Liquid flammable			III	E1	355 Y344	60 L 10 L	366	220 L
1,3,5-Trimethyl-2,4,6-trinitrobenzene	FORBIDDEN											
Trinitroacetic acid	FORBIDDEN											
Trinitroacetonitrile	FORBIDDEN											
Trinitroamine cobalt	FORBIDDEN											
Trinitroaniline	0153	1.1D							FORBIDDEN		FORBIDDEN	
Trinitroanisole	0213	1.1D							FORBIDDEN		FORBIDDEN	
Trinitrobenzene , dry or wetted with less than 30% water, by mass	0214	1.1D							FORBIDDEN		FORBIDDEN	
Trinitrobenzenesulphonic acid	0386	1.1D							FORBIDDEN		FORBIDDEN	
Trinitrobenzene, wetted with not less than 30% water, by mass	1354	4.1		Solid flammable	BE 3	A40	I	E0	451	0.5 kg	451	0.5 kg
Trinitrobenzene, wetted with not less than 10% water, by mass	3367	4.1		Solid flammable	BE 3	A40	I	E0	451	0.5 kg	451	0.5 kg
Trinitrobenzoic acid , dry or wetted with less than 30% water, by mass	0215	1.1D							FORBIDDEN		FORBIDDEN	
Trinitrobenzoic acid, wetted with not less than 30% water, by mass	1355	4.1		Solid flammable	BE 3	A40	I	E0	451	0.5 kg	451	0.5 kg
Trinitrobenzoic acid, wetted with not less than 10% water, by mass	3368	4.1		Solid flammable	BE 3	A40	I	E0	451	0.5 kg	451	0.5 kg
Trinitrochlorobenzene	0155	1.1D							FORBIDDEN		FORBIDDEN	
Trinitrochlorobenzene, wetted with not less than 10% water, by mass	3365	4.1		Solid flammable	BE 3	A40	I	E0	451	0.5 kg	451	0.5 kg
Trinitro-m-cresol	0216	1.1D							FORBIDDEN		FORBIDDEN	
2,4,6-Trinitro-1,3-diazobenzene	FORBIDDEN											
Trinitroethanol	FORBIDDEN											

Name	UN No.	Class or division	Subsidiary risk	Labels	State variations	Special provisions	UN packing group	Excepted quantity	Passenger and cargo aircraft		Cargo aircraft only	
									Packing instruction	Max. net quantity per package	Packing instruction	Max. net quantity per package
1	2	3	4	5	6	7	8	9	10	11	12	13
Trinitroethylnitrate		FORBIDDEN										
Trinitrofluorenone	0387	1.1D							FORBIDDEN		FORBIDDEN	
Trinitromethane		FORBIDDEN										
Trinitronaphthalene	0217	1.1D							FORBIDDEN		FORBIDDEN	
Trinitrophenetole	0218	1.1D							FORBIDDEN		FORBIDDEN	
Trinitrophenol , dry or wetted with less than 30% water, by mass	0154	1.1D							FORBIDDEN		FORBIDDEN	
Trinitrophenol, wetted with not less than 30% water, by mass	1344	4.1		Solid flammable	BE 3	A40	I	E0	451	1 kg	451	15 kg
Trinitrophenol, wetted with not less than 10% water, by mass	3364	4.1		Solid flammable	BE 3	A40	I	E0	451	0.5 kg	451	0.5 kg
2,4,6-Trinitrophenyl guanidine (dry)		FORBIDDEN										
Trinitrophenylmethylnitramine	0208	1.1D							FORBIDDEN		FORBIDDEN	
2,4,6-Trinitrophenyl nitramine		FORBIDDEN										
2,4,6-Trinitrophenyl trimethylol methyl nitramine trinitrate (dry)		FORBIDDEN										
Trinitroresorcinol , dry or wetted with less than 20% water, or mixture of alcohol and water, by mass	0219	1.1D							FORBIDDEN		FORBIDDEN	
Trinitroresorcinol, wetted with not less than 20% water, or mixture of alcohol and water, by mass	0394	1.1D							FORBIDDEN		FORBIDDEN	
2,4,6-Trinitroso-3-methyl nitraminoanisole		FORBIDDEN										
Trinitrotetramine cobalt nitrate		FORBIDDEN										
Trinitrotoluene , dry or wetted with less than 30% water, by mass	0209	1.1D							FORBIDDEN		FORBIDDEN	
Trinitrotoluene and hexanitrostilbene mixture	0388	1.1D							FORBIDDEN		FORBIDDEN	
Trinitrotoluene and trinitrobenzene mixture	0388	1.1D							FORBIDDEN		FORBIDDEN	
Trinitrotoluene mixture containing trinitrobenzene and hexanitrostilbene	0389	1.1D							FORBIDDEN		FORBIDDEN	

Name	UN No.	Class or division	Subsidiary risk	Labels	State variations	Special provisions	UN packing group	Excepted quantity	Passenger and cargo aircraft		Cargo aircraft only	
									Packing instruction	Max. net quantity per package	Packing instruction	Max. net quantity per package
1	2	3	4	5	6	7	8	9	10	11	12	13
Trinitrotoluene, wetted with not less than 30% water, by mass	1356	4.1		Solid flammable	BE 3	A40	I	E0	451	0.5 kg	451	0.5 kg
Trinitrotoluene, wetted with not less than 10% water, by mass	3366	4.1		Solid flammable	BE 3	A40	I	E0	451	0.5 kg	451	0.5 kg
2,4,6-Trinitro-1,3,5-triazido benzene (dry)	FORBIDDEN											
Tripropylamine	2260	3	8	Liquid flammable & Corrosive			III	E1	354 Y342	5 L 1 L	365	60 L
Tripropylene	2057	3		Liquid flammable		A3	II III	E2 E1	353 Y341 355 Y344	5 L 1 L 60 L 10 L	364 366	60 L 220 L
Tris-(1-aziridinyl) phosphine oxide solution	2501	6.1		Toxic		A3	II III	E4 E1	654 Y641 655 Y642	5 L 1 L 60 L 2 L	662 663	60 L 220 L
Tris, bis-bifluoroamino diethoxy propane (TVOPA)	FORBIDDEN											
Tritonal	0390	1.1D							FORBIDDEN		FORBIDDEN	
Tropilidene, see Cycloheptatriene												
Tungsten hexafluoride	2196	2.3	8		AU 1 CA 7 IR 3 NL 1 US 3	A2			FORBIDDEN		FORBIDDEN	
Turpentine	1299	3		Liquid flammable			III	E1	355 Y344	60 L 10 L	366	220 L
Turpentine substitute †	1300	3		Liquid flammable		A3	II III	E2 E1	353 Y341 355 Y344	5 L 1 L 60 L 10 L	364 366	60 L 220 L
Tyre assemblies inflated, unserviceable, damaged or above maximum rated pressure	FORBIDDEN											
U												
Undecane	2330	3		Liquid flammable			III	E1	355 Y344	60 L 10 L	366	220 L
+ Uranium hexafluoride, radioactive material, excepted package , less than 0.1 kg per package, non-fissile or fissile-excepted	3507	8	7	Corrosive		A139 A194	I	E0	See 877		See 877	

Name	UN No.	Class or division	Subsidiary risk	Labels	State variations	Special provisions	UN packing group	Excepted quantity	Passenger and cargo aircraft		Cargo aircraft only	
									Packing instruction	Max. net quantity per package	Packing instruction	Max. net quantity per package
1	2	3	4	5	6	7	8	9	10	11	12	13
Urea hydrogen peroxide	1511	5.1	8	Oxidizer & Corrosive			III	E1	559 Y545	25 kg 5 kg	563	100 kg
Urea nitrate , dry or wetted with less than 20% water, by mass	0220	1.1D							FORBIDDEN		FORBIDDEN	
Urea nitrate, wetted with not less than 20% water, by mass	1357	4.1		Solid flammable	BE 3	A40 A101	I	E0	451	1 kg	451	15 kg
Urea nitrate, wetted with not less than 10% water, by mass	3370	4.1		Solid flammable	BE 3	A40	I	E0	451	0.5 kg	451	0.5 kg
V												
Valeral, see Valeraldehyde												
Valeraldehyde	2058	3		Liquid flammable			II	E2	353 Y341	5 L 1 L	364	60 L
n-Valeraldehyde, see Valeraldehyde												
Valeric aldehyde, see Valeraldehyde												
Valeryl chloride	2502	8	3	Corrosive & Liquid flammable			II	E2	851 Y840	1 L 0.5 L	855	30 L
Vanadium compound, n.o.s.*	3285	6.1		Toxic		A3 A5	I II III	E5 E4 E1	666 669 Y644 670 Y645	5 kg 25 kg 1 kg 100 kg 10 kg	673 676 677	50 kg 100 kg 200 kg
Vanadium (IV) oxide sulphate, see Vanadyl sulphate												
Vanadium oxysulphate, see Vanadyl sulphate												
Vanadium oxytrichloride	2443	8		Corrosive	AU 1 CA 7 IR 3 NL 1 US 3	A1	II	E0	FORBIDDEN		855	30 L
Vanadium pentoxide , non-fused form	2862	6.1		Toxic			III	E1	670 Y645	100 kg 10 kg	677	200 kg

Name	UN No.	Class or division	Subsidiary risk	Labels	State variations	Special provisions	UN packing group	Excepted quantity	Passenger and cargo aircraft		Cargo aircraft only	
									Packing instruction	Max. net quantity per package	Packing instruction	Max. net quantity per package
1	2	3	4	5	6	7	8	9	10	11	12	13
Vanadium tetrachloride	2444	8		Corrosive	AU 1 CA 7 IR 3 NL 1 US 3	A1	I	E0	FORBIDDEN		854	2.5 L
Vanadium trichloride	2475	8		Corrosive			III	E1	860 Y845	25 kg 5 kg	864	100 kg
Vanadyl sulphate	2931	6.1		Toxic			II	E4	669 Y644	25 kg 1 kg	676	100 kg
Vehicle, flammable gas powered	3166	9		Miscellaneous		A67 A70 A87 A118 A120 A134		E0	FORBIDDEN		951	No limit
Vehicle, flammable liquid powered	3166	9		Miscellaneous		A67 A70 A87 A118 A120 A134		E0	950	No limit	950	No limit
Vehicle, fuel cell, flammable gas powered †	3166	9		Miscellaneous		A67 A70 A87 A118 A120 A134 A176		E0	FORBIDDEN		951	No limit
Vehicle, fuel cell, flammable liquid powered †	3166	9		Miscellaneous		A67 A70 A87 A118 A120 A134 A176		E0	950	No limit	950	No limit
Vehicles, self-propelled, see Battery-powered equipment or Battery-powered vehicle or Vehicle (flammable gas powered) or Vehicle (flammable liquid powered)												
Villiamite, see Sodium fluoride, solid (UN No. 1690)												
Vinyl acetate, stabilized	1301	3		Liquid flammable			II	E2	353 Y341	5 L 1 L	364	60 L

Name	UN No.	Class or division	Subsidiary risk	Labels	State variations	Special provisions	UN packing group	Excepted quantity	Passenger and cargo aircraft		Cargo aircraft only	
									Packing instruction	Max. net quantity per package	Packing instruction	Max. net quantity per package
1	2	3	4	5	6	7	8	9	10	11	12	13
Vinylbenzene, see Styrene monomer, stabilized												
Vinyl bromide, stabilized	1085	2.1		Gas flammable	AU 1 CA 7 IR 3 NL 1 US 3	A1		E0	FORBIDDEN		200	150 kg
Vinyl butyrate, stabilized	2838	3		Liquid flammable			II	E2	353 Y341	5 L 1 L	364	60 L
Vinyl chloride, stabilized	1086	2.1		Gas flammable	AU 1 CA 7 IR 3 NL 1 US 3 US 4	A1		E0	FORBIDDEN		200	150 kg
Vinyl chloroacetate	2589	6.1	3	Toxic & Liquid flammable			II	E4	654 Y641	5 L 1 L	662	60 L
Vinyl ethyl ether, stabilized	1302	3		Liquid flammable			I	E3	351	1 L	361	30 L
Vinyl fluoride, stabilized	1860	2.1		Gas flammable	AU 1 CA 7 IR 3 NL 1 US 3	A1		E0	FORBIDDEN		200	150 kg
Vinylidene chloride, stabilized	1303	3		Liquid flammable			I	E3	351	1 L	361	30 L
Vinyl isobutyl ether, stabilized	1304	3		Liquid flammable			II	E2	353 Y341	5 L 1 L	364	60 L
Vinyl methyl ether, stabilized	1087	2.1		Gas flammable	AU 1 CA 7 IR 3 NL 1 US 3	A1		E0	FORBIDDEN		200	150 kg
Vinyl nitrate polymer	FORBIDDEN											
Vinylpyridines, stabilized	3073	6.1	3 8	Toxic & Liquid flammable & Corrosive			II	E4	653 Y640	1 L 0.5 L	660	30 L
Vinyltoluenes, stabilized	2618	3		Liquid flammable			III	E1	355 Y344	60 L 10 L	366	220 L
Vinyltrichlorosilane	1305	3	8	Liquid flammable & Corrosive	AU 1 CA 7 IR 3 NL 1 US 3		II	E0	FORBIDDEN		377	5 L

Name	UN No.	Class or division	Subsidiary risk	Labels	State variations	Special provisions	UN packing group	Excepted quantity	Passenger and cargo aircraft		Cargo aircraft only	
									Packing instruction	Max. net quantity per package	Packing instruction	Max. net quantity per package
1	2	3	4	5	6	7	8	9	10	11	12	13
W												
Warheads for guided missiles, see Warheads, rocket												
Warheads, rocket with burster or expelling charge †	0370	1.4D		Explosive 1.4				E0	FORBIDDEN		130	75 kg
Warheads, rocket with burster or expelling charge †	0371	1.4F							FORBIDDEN		FORBIDDEN	
Warheads, rocket with bursting charge †	0286	1.1D							FORBIDDEN		FORBIDDEN	
Warheads, rocket with bursting charge †	0287	1.2D							FORBIDDEN		FORBIDDEN	
Warheads, rocket with bursting charge †	0369	1.1F							FORBIDDEN		FORBIDDEN	
Warheads, torpedo with bursting charge †	0221	1.1D							FORBIDDEN		FORBIDDEN	
Water-reactive liquid, n.o.s.*	3148	4.3		Danger if wet		A3	I	E0	FORBIDDEN		480	1 L
							II	E2	478	1 L	481	5 L
							III	E1	479	5 L	482	60 L
Water-reactive liquid, corrosive, n.o.s.*	3129	4.3	8	Danger if wet & Corrosive		A3	I	E0	FORBIDDEN		480	1 L
							II	E0	FORBIDDEN		481	5 L
							III	E1	479	5 L	482	60 L
Water-reactive liquid, toxic, n.o.s.*	3130	4.3	6.1	Danger if wet & Toxic		A3	I	E0	FORBIDDEN		480	1 L
							II	E0	FORBIDDEN		481	5 L
							III	E1	479	5 L	482	60 L
Water-reactive solid, n.o.s.*	2813	4.3		Danger if wet		A3	I	E0	FORBIDDEN		488	15 kg
							II	E2	484	15 kg	490	50 kg
									Y475	5 kg		
							III	E1	486	25 kg	491	100 kg
									Y477	10 kg		
Water-reactive solid, corrosive, n.o.s.*	3131	4.3	8	Danger if wet & Corrosive		A3	I	E0	FORBIDDEN		488	15 kg
							II	E2	483	15 kg	490	50 kg
									Y475	5 kg		
							III	E1	486	25 kg	491	100 kg
									Y476	5 kg		
Water-reactive solid, flammable, n.o.s.*	3132	4.3	4.1	Danger if wet & Solid flammable		A3	I	E0	FORBIDDEN		488	15 kg
							II	E2	483	15 kg	490	50 kg
									Y475	5 kg		
							III	E1	486	25 kg	491	100 kg
									Y476	5 kg		

Name	UN No.	Class or division	Subsidiary risk	Labels	State variations	Special provisions	UN packing group	Excepted quantity	Passenger and cargo aircraft		Cargo aircraft only	
									Packing instruction	Max. net quantity per package	Packing instruction	Max. net quantity per package
1	2	3	4	5	6	7	8	9	10	11	12	13
Water-reactive solid, oxidizing, n.o.s.*	3133	4.3	5.1		AU 1 CA 7 IR 3 NL 1 US 3	A2 A3			FORBIDDEN		FORBIDDEN	
Water-reactive solid, self-heating, n.o.s.*	3135	4.3	4.2	Danger if wet & Spontaneous combustion		A3	I II III	E0 E2 E1	FORBIDDEN 483 486	15 kg 25 kg	488 490 491	15 kg 50 kg 100 kg
Water-reactive solid, toxic, n.o.s.*	3134	4.3	6.1	Danger if wet & Toxic		A3	I II III	E0 E2 E1	FORBIDDEN 483 Y474 486 Y477	15 kg 1 kg 25 kg 10 kg	488 490 491	15 kg 50 kg 100 kg
Wheelchair, electric with batteries, see Battery-powered equipment or Battery-powered vehicle												
White arsenic, see Arsenic trioxide												
White spirit, see Turpentine substitute												
Wood preservatives, liquid	1306	3		Liquid flammable		A3	II III	E2 E1	353 Y341 355 Y344	5 L 1 L 60 L 10 L	364 366	60 L 220 L
+ Wool waste, wet	1387	4.2				A2			FORBIDDEN		FORBIDDEN	
X												
Xanthates	3342	4.2		Spontaneous combustion		A3	II III	E2 E1	467 469	15 kg 25 kg	470 471	50 kg 100 kg
Xenon	2036	2.2		Gas non-flammable		A69		E1	200	75 kg	200	150 kg
Xenon, refrigerated liquid	2591	2.2		Gas non-flammable				E1	202	50 kg	202	500 kg
Xylenes	1307	3		Liquid flammable		A3	II III	E2 E1	353 Y341 355 Y344	5 L 1 L 60 L 10 L	364 366	60 L 220 L
Xylenols, liquid	3430	6.1		Toxic			II	E4	654 Y641	5 L 1 L	662	60 L
Xylenols, solid	2261	6.1		Toxic			II	E4	669 Y644	25 kg 1 kg	676	100 kg
Xylidines, liquid	1711	6.1		Toxic			II	E4	654 Y641	5 L 1 L	662	60 L

Name	UN No.	Class or division	Subsidiary risk	Labels	State variations	Special provisions	UN packing group	Excepted quantity	Passenger and cargo aircraft		Cargo aircraft only	
									Packing instruction	Max. net quantity per package	Packing instruction	Max. net quantity per package
1	2	3	4	5	6	7	8	9	10	11	12	13
Xylidines, solid	3452	6.1		Toxic			II	E4	669 Y644	25 kg 1 kg	676	100 kg
Xylols, see Xylenes												
Xylyl bromide, liquid	1701	6.1		Toxic	AU 1 CA 7 IR 3 NL 1 US 3	A1	II	E0	FORBIDDEN		661	60 L
Xylyl bromide, solid	3417	6.1		Toxic			II	E4	669	25 kg	676	100 kg
p-Xylyl diazide	FORBIDDEN											
Z												
Zinc ammonium nitrite	1512	5.1		Oxidizer			II	E2	558 Y544	5 kg 2.5 kg	562	25 kg
Zinc arsenate	1712	6.1		Toxic			II	E4	669 Y644	25 kg 1 kg	676	100 kg
Zinc arsenate and zinc arsenite mixture	1712	6.1		Toxic			II	E4	669 Y644	25 kg 1 kg	676	100 kg
Zinc arsenite	1712	6.1		Toxic			II	E4	669 Y644	25 kg 1 kg	676	100 kg
Zinc ashes	1435	4.3		Danger if wet		A3	III	E1	486 Y477	25 kg 10 kg	491	100 kg
Zinc bisulphite solution, see Bisulphites, aqueous solution, n.o.s.												
Zinc bromate	2469	5.1		Oxidizer			III	E1	559 Y546	25 kg 10 kg	563	100 kg
Zinc chlorate	1513	5.1		Oxidizer			II	E2	558 Y544	5 kg 2.5 kg	562	25 kg
Zinc chloride, anhydrous	2331	8		Corrosive			III	E1	860 Y845	25 kg 5 kg	864	100 kg
Zinc chloride solution	1840	8		Corrosive		A3	III	E1	852 Y841	5 L 1 L	856	60 L
Zinc cyanide	1713	6.1		Toxic	US 4		I	E5	666	5 kg	673	50 kg
Zinc dithionite	1931	9		Miscellaneous			III	E1	956	100 kg	956	200 kg
Zinc dust	1436	4.3	4.2	Danger if wet & Spontaneous combustion		A3	I II III	E0 E2 E1	FORBIDDEN 483 486	 15 kg 25 kg	488 490 491	15 kg 50 kg 100 kg
Zinc fluorosilicate	2855	6.1		Toxic			III	E1	670 Y645	100 kg 10 kg	677	200 kg

Name	UN No.	Class or division	Subsidiary risk	Labels	State variations	Special provisions	UN packing group	Excepted quantity	Passenger and cargo aircraft		Cargo aircraft only	
									Packing instruction	Max. net quantity per package	Packing instruction	Max. net quantity per package
1	2	3	4	5	6	7	8	9	10	11	12	13
Zinc hexafluorosilicate, see Zinc fluorosilicate												
Zinc hydrosulphite	1931	9		Miscellaneous			III	E1	956	100 kg	956	200 kg
Zinc nitrate	1514	5.1		Oxidizer			II	E2	558 Y544	5 kg 2.5 kg	562	25 kg
Zinc permanganate	1515	5.1		Oxidizer			II	E2	558 Y544	5 kg 2.5 kg	562	25 kg
Zinc peroxide	1516	5.1		Oxidizer			II	E2	558 Y544	5 kg 2.5 kg	562	25 kg
Zinc phosphide	1714	4.3	6.1	Danger if wet & Toxic			I	E0	FORBIDDEN		487	15 kg
Zinc powder	1436	4.3	4.2	Danger if wet & Spontaneous combustion		A3	I II III	E0 E2 E1	FORBIDDEN 483 486	15 kg 25 kg	488 490 491	15 kg 50 kg 100 kg
Zinc resinate	2714	4.1		Solid flammable			III	E1	446 Y443	25 kg 10 kg	449	100 kg
Zinc selenate, see Selenates												
Zinc selenite, see Selenites												
Zinc silicofluoride, see Zinc fluorosilicate												
Zirconium, dry , coiled wire, finished metal sheets, strip (thinner than 254 microns but not thinner than 18 microns)	2858	4.1		Solid flammable			III	E1	446 Y443	25 kg 10 kg	449	100 kg
Zirconium, dry , finished sheets, strip or coiled wire (thinner than 18 microns)	2009	4.2		Spontaneous combustion		A3	III	E1	469	25 kg	471	100 kg
Zirconium hydride	1437	4.1		Solid flammable			II	E2	445 Y441	15 kg 5 kg	448	50 kg
Zirconium nitrate	2728	5.1		Oxidizer			III	E1	559 Y546	25 kg 10 kg	563	100 kg
Zirconium picramate , dry or wetted with less than 20% water, by mass	0236	1.3C							FORBIDDEN		FORBIDDEN	
Zirconium picramate, wetted with not less than 20% water, by mass	1517	4.1		Solid flammable	BE 3	A40	I	E0	451	1 kg	451	15 kg
Zirconium powder, dry	2008	4.2		Spontaneous combustion		A3	II III	E2 E1	FORBIDDEN 467 469	15 kg 25 kg	FORBIDDEN 470 471	50 kg 100 kg

Chapter 2

3-2-231

Name	UN No.	Class or division	Subsidiary risk	Labels	State variations	Special provisions	UN packing group	Excepted quantity	Passenger and cargo aircraft		Cargo aircraft only	
									Packing instruction	Max. net quantity per package	Packing instruction	Max. net quantity per package
1	2	3	4	5	6	7	8	9	10	11	12	13
Zirconium powder, wetted with not less than 25% water (a visible excess of water must be present) (a) mechanically produced, particle size less than 53 microns; (b) chemically produced, particle size less than 840 microns	1358	4.1		Solid flammable		A35	II	E2	445 Y441	15 kg 5 kg	448	50 kg
Zirconium scrap	1932	4.2			AU 1 CA 7 IR 3 NL 1 US 3	A2 A3			FORBIDDEN		FORBIDDEN	
Zirconium suspended in a flammable liquid †	1308	3		Liquid flammable	AU 1 CA 7 IR 3 NL 1 US 2	A1 A3 A108	I II III	E0 E2 E1	FORBIDDEN 353 Y341 355 Y344	5 L 1 L 60 L 10 L	361 364 366	30 L 60 L 220 L
Zirconium tetrachloride	2503	8		Corrosive			III	E1	860 Y845	25 kg 5 kg	864	100 kg

Chapter 3

SPECIAL PROVISIONS

Parts of this Chapter are affected by State Variations AE 3, AU 1, AU 2, CA 7, HR 3, IR 3, JM 1, KP 2, MO 2, NL 1, US 11, ZA 1; see Table A-1

Table 3-2 lists the special provisions referred to in column 7 of Table 3-1 and the information contained in them is additional to that shown for the relevant entry. Where the wording of the special provision is equivalent to that in the UN Model Regulations, the UN special provision number is shown in parentheses.

Table 3-2. Special provisions

<i>TIs</i>	<i>UN</i>	
≠	A1	<p>This article or substance may be transported on passenger aircraft only with the prior approval of the appropriate authority of the State of Origin and the State of the Operator under the written conditions established by those authorities. The conditions must include the quantity limitations and packing requirements and these must comply with S-3;1.2.2 of the Supplement. A copy of the documents of approval, showing the quantity limitations and packing requirements, must accompany the consignment. The article or substance may be carried on cargo aircraft in accordance with columns 12 and 13 of Table 3-1.</p> <p>When States, other than the State of Origin and the State of the Operator, have notified ICAO that they require prior approval of shipments made under this special provision, approval must also be obtained from these States, as appropriate.</p>
≠	A2	<p>This article or substance may be transported on cargo aircraft only with the prior approval of the appropriate authority of the State of Origin and the State of the Operator under the written conditions established by those authorities.</p> <p>When States, other than the State of Origin and the State of the Operator, have notified ICAO that they require prior approval of shipments made under this special provision, approval must also be obtained from the States of transit, overflight and destination, as appropriate.</p> <p>In each case, the conditions must include the quantity limitations and packing requirements and these must comply with S-3;1.2.3 of the Supplement. A copy of the document(s) of approval, showing the quantity limitations and the packing and labelling requirements, must accompany the consignment.</p>
	A3	<p>(223) If the chemical or physical properties of a substance covered by this description are such that, when tested, it does not meet the established defining criteria for the class or division listed in column 3, or any other class or division, it is not subject to these Instructions.</p>
≠	A4	<p>Liquids having a vapour inhalation toxicity of Packing Group I are forbidden on both passenger and cargo aircraft.</p> <p>Liquids having a mist inhalation toxicity of Packing Group I are forbidden on a passenger aircraft. They may be carried on cargo aircraft providing they are packed in accordance with the packing instructions for the Packing Group I substance and the maximum net quantity per package does not exceed 5 L. Transport in accordance with this special provision must be noted on the dangerous goods transport document.</p>
≠	A5	<p>Solids having an inhalation toxicity of Packing Group I are forbidden on passenger aircraft. They may be carried on cargo aircraft providing they are packed in accordance with the packing instructions for the Packing Group I substance and the maximum net quantity per package does not exceed 15 kg. Transport in accordance with this special provision must be noted on the dangerous goods transport document.</p>
	A6	<p>(43) When offered for carriage as pesticides, these substances must be carried under the relevant pesticide entry and in accordance with the relevant pesticide provisions (see 2;6.2.3 and 2;6.2.4).</p>
	A7	<p>Not used.</p>
	A8	<p>(322) When transported in non-friable tablet form, these goods are assigned to Packing Group III.</p>

<i>TIs</i>	<i>UN</i>	
A9		Alcoholic beverages containing not more than 70 per cent alcohol by volume, when packed in receptacles of 5 litres or less, are not subject to these Instructions when carried as cargo.
A10	(39)	This substance is not subject to these Instructions when it contains less than 30 per cent or not less than 90 per cent silicon.
A11	(305)	These substances are not subject to these Instructions when in concentrations of not more than 50 mg/kg.
A12	(45)	Antimony sulphides and oxides which contain not more than 0.5 per cent of arsenic calculated on the total mass are not subject to these Instructions.
A13	(47)	Ferricyanides and ferrocyanides are not subject to these Instructions.
A14		Not used.
A15	(59)	These substances are not subject to these Instructions when they contain not more than 50 per cent magnesium.
A16	(62)	This substance is not subject to these Instructions when it does not contain more than 4 per cent sodium hydroxide.
A17		These substances must not be classified and transported unless authorized by the appropriate authority of the State of Origin on the basis of results from Series 2 tests and a Series 6(c) test on packages as prepared for transport.
≠	A18 (66)	Cinnabar is not subject to these Instructions.
	A19 (225)	Fire extinguishers under this entry may include installed actuating cartridges (cartridges, power device of Division 1.4C or 1.4S), without changing the classification of Division 2.2 provided the total quantity of deflagrating (propellant) explosives does not exceed 3.2 grams per extinguishing unit.
+		Fire extinguishers must be manufactured, tested, approved and labelled according to the provisions applied in the State of Manufacture. Fire extinguishers under this entry include: <ul style="list-style-type: none"> a) portable fire extinguishers for manual handling and operation; b) fire extinguishers for installation in aircraft; c) fire extinguishers mounted on wheels for manual handling; d) fire extinguishing equipment or machinery mounted on wheels or wheeled platforms or units transported similar to (small) trailers; and e) fire extinguishers composed of a non-rollable pressure drum and equipment, and handled, for example, by fork lift or crane when loaded or unloaded.
A20		During the course of transport this substance must be protected from direct sunlight and all sources of heat and be placed in an adequately ventilated area. A statement to this effect must be included in the Dangerous Goods Transport Document.
A21		This entry only applies to vehicles powered by wet batteries, sodium batteries, lithium metal batteries or lithium ion batteries and equipment powered by wet batteries or sodium batteries which are transported with these batteries installed. <p>For the purpose of this special provision, vehicles are self-propelled apparatus designed to carry one or more persons or goods. Examples of such vehicles are electrically-powered cars, motorcycles, scooters, three- and four-wheeled vehicles or motorcycles, battery-assisted bicycles, wheelchairs, lawn tractors, boats and aircraft. Examples of equipment are lawnmowers, cleaning machines or model boats and model aircraft.</p> <p>Equipment powered by lithium metal batteries or lithium ion batteries must be consigned under the entries UN 3091 Lithium metal batteries contained in equipment or UN 3091 Lithium metal batteries packed with equipment or UN 3481 Lithium ion batteries contained in equipment or UN 3481 Lithium ion batteries packed with equipment, as appropriate.</p>

TIs UN

Vehicles or equipment that also contain an internal combustion engine must be consigned under the entries UN 3166 **Engine, internal combustion, flammable gas powered** or UN 3166 **Engine, internal combustion, flammable liquid powered** or UN 3166 **Vehicle, flammable gas powered** or UN 3166 **Vehicle, flammable liquid powered**, as appropriate. Hybrid electric vehicles powered by both an internal combustion engine and wet batteries, sodium batteries, lithium metal batteries or lithium ion batteries, transported with the battery(ies) installed, must be consigned under the entries UN 3166 **Vehicle, flammable gas powered** or UN 3166 **Vehicle, flammable liquid powered**, as appropriate.

Vehicles or equipment powered by a fuel cell engine must be consigned under the entries UN 3166 **Vehicle, fuel cell, flammable gas powered** or UN 3166 **Vehicle, fuel cell, flammable liquid powered**, or UN 3166 **Engine, fuel cell, flammable gas powered** or UN 3166 **Engine, fuel cell, flammable liquid powered**, as appropriate.

- A22 The classification of this substance will vary with particle size and packaging, but borderlines have not been experimentally determined. The appropriate classification must be made using the procedure for the classification of explosives.
- A23 (325) In the case of non-fissile or fissile excepted uranium hexafluoride, the material must be classified under UN 2978.
- A24 The total quantity of explosive substance contained in the shaped charges and the detonating cord must not exceed 10 kg per assembled perforating gun.
- A25 (205) This entry must not be used for Pentachlorophenol (UN 3155).
- A26 (119) Refrigerating machines include air conditioning units and machines or other appliances which have been designed for the specific purpose of keeping food or other items at low temperature in an internal compartment. Refrigerating machines and refrigerating machine components are considered not subject to these Instructions if containing less than 12 kg of a gas in Division 2.2 or if containing less than 12 L ammonia solution (UN 2672).
- A27 (276) This includes any substance which is not covered by any of the other classes but which has narcotic, noxious or other properties such that, in the event of spillage or leakage on an aircraft, extreme annoyance or discomfort could be caused to crew members so as to prevent the correct performance of assigned duties.
- ≠ A28 (135) The dihydrated sodium salt of dichloroisocyanuric acid does not meet the criteria for inclusion in Division 5.1 and is not subject to these Instructions unless meeting the criteria for inclusion in another class or division.
- A29 (138) p-Bromobenzyl cyanide is not subject to these Instructions.
- A30 (273) Maneb and maneb preparations stabilized against self-heating need not be classified in Division 4.2 when it can be demonstrated by testing that a cubic metre of the substance does not self-ignite and that the temperature at the centre of the sample does not exceed 200°C, when the sample is maintained at a temperature of not less than 75°C ± 2°C for a period of 24 hours.
- A31 (141) Products which have undergone sufficient heat treatment so they present no hazard during transport are not subject to these Instructions.
- ≠ A32 Safety devices, electrically initiated and safety devices, pyrotechnic installed in vehicles, vessels or aircraft or in completed components such as steering columns, door panels, seats, etc., which are not capable of inadvertent activation are not subject to these Instructions when carried as cargo. The words “not restricted” and the special provision number A32 must be provided on the air waybill when an air waybill is issued.
- A33 (103) Ammonium nitrites and mixtures of an inorganic nitrite with an ammonium salt are forbidden.
- A34 (113) The transport of chemically unstable mixtures is forbidden.
- A35 This substance is not subject to these Instructions when:
- mechanically produced, particle size more than 53 microns; or
 - chemically produced, particle size more than 840 microns.
- A36 The provisions of Special Provision A2 apply to this entry for Packing Group I only and the provisions of Special Provision A1 apply to this entry for Packing Group II only, as applicable.
- A37 This entry is not intended to include Ammonium permanganate, the transport of which is forbidden under any circumstances.

<i>TIs</i>	<i>UN</i>
A38	(207) Polymeric beads and moulding compounds may be made from polystyrene, poly(methyl methacrylate) or other polymeric material.
A39	This substance possesses some dangerous explosive properties when transported in large volumes.
A40	(28) This substance may be transported under provisions of Division 4.1 only if it is so packed that the percentage of diluent will not fall below that stated at any time during transport.
A41	Permeation devices that contain dangerous goods and that are used for calibrating air quality monitoring devices are not subject to these Instructions when carried as cargo provided the following requirements are met: <ol style="list-style-type: none"> a) Each device must be constructed of a material compatible with the dangerous goods it contains; b) The total contents of dangerous goods in each device is limited to 2 millilitres and the device must not be liquid full at 55°C; c) Each permeation device must be placed in a sealed, high impact-resistant, tubular inner packaging of plastic or equivalent material. Sufficient absorbent material must be contained in the inner packaging to completely absorb the contents of the device. The closure of the inner packaging must be securely held in place with wire, tape or other positive means; d) Each inner packaging must be contained in a secondary packaging constructed of metal, or plastic having a minimum thickness of 1.5 mm. The secondary packaging must be hermetically sealed; e) The secondary packaging must be securely packed in strong outer packaging. The completed package must be capable of withstanding, without breakage or leakage of any inner packaging and without significant reduction in effectiveness: <ol style="list-style-type: none"> i) the following free drops onto a rigid, non-resilient, flat and horizontal surface from a height of 1.8 m: <ul style="list-style-type: none"> — one drop flat on the bottom; — one drop flat on the top; — one drop flat on the long side; — one drop flat on the short side; — one drop on a corner at the junction of three intersecting edges; and ii) a force applied to the top surface for a duration of 24 hours, equivalent to the total weight of identical packages if stacked to a height of 3 m (including the test sample). <p style="text-align: center;"><i>Note.— Each of the above tests may be performed on different but identical packages.</i></p> f) The gross mass of the completed package must not exceed 30 kg.
A42	(249) Ferrocium (lighter flints), stabilized against corrosion, with a minimum iron content of 10 per cent are not subject to these Instructions.
A43	(210) Toxins from plant, animal or bacterial sources which contain infectious substances, or toxins that are contained in infectious substances, must be classified as Division 6.2.
A44	The entry chemical kit or first-aid kit is intended to apply to boxes, cases, etc., containing small quantities of various dangerous goods which are used, for example, for medical, analytical or testing or repair purposes. Components must not react dangerously (see 4;1.1.8). The packing group assigned to the kit as a whole must be the most stringent packing group assigned to any individual substance in the kit. The assigned packing group must be shown on the dangerous goods transport document. Where the kit contains only dangerous goods to which no packing group is assigned, a packing group must not be indicated on the dangerous goods transport document. <p>The only dangerous goods which are permitted in the kits are substances which may be transported as:</p> <ol style="list-style-type: none"> a) excepted quantities as specified in column 9 of Table 3-1, provided the inner packagings and quantities are as prescribed in 5.1.2 and 5.2.1 a); or b) limited quantities under 3;4.1.2.
A45	Not used.

Note.— See Packing Instructions 965-970.

<i>TIs</i>	<i>UN</i>
A46	Mixtures of solids which are not subject to these Instructions and flammable liquids may be transported under this entry without first applying the classification criteria of Division 4.1, providing there is no free liquid visible at the time the substance is packaged and, for single packagings, the packaging must pass a leakproofness test at the Packing Group II level. Small inner packagings consisting of sealed packets or articles containing less than 10 mL of a Packing Group II or III flammable liquid absorbed into a solid material are not subject to these Instructions provided there is no free liquid in the packet or articles.
A47	(219) Genetically modified micro-organisms (GMMOs) and genetically modified organisms (GMOs) packed and marked in accordance with Packing Instruction 959 are not subject to any other requirements in these Instructions when carried as cargo. If GMMOs or GMOs meet the definition in 2;6 of a toxic substance or an infectious substance and meet the criteria for inclusion in Division 6.1 or 6.2, the requirements in these Instructions for transporting toxic substances or infectious substances apply.
A48	Packaging tests are not considered necessary.
A49	Other inert material or inert material mixture may be used at the discretion of the appropriate authority of the State of Origin, provided this inert material has identical phlegmatizing properties.
A50	Mixtures of solids which are not subject to these Instructions and toxic liquids may be transported under this entry without first applying the classification criteria of Division 6.1, providing there is no free liquid visible at the time the substance is packaged and, for single packagings, the packaging must pass a leakproofness test at the Packing Group II level. This entry must not be used for solids containing a Packing Group I liquid.
A51	Irrespective of the limit specified in column 11 of Table 3-1, aircraft batteries up to a limit of 100 kg net mass per package may be transported. Transport in accordance with this special provision must be noted on the dangerous goods transport document. <i>Note.— This special provision applies to UN 2794 Batteries, wet, filled with acid and UN 2795 Batteries, wet, filled with alkali only.</i>
A52	(228) Mixtures not meeting the criteria for flammable gases (Division 2.1) must be transported under UN 3163.
A53	(37) This substance is not subject to these Instructions when coated.
A54	(32) This substance is not subject to these Instructions when in any other form.
A55	(142) Solvent extracted soya bean meal containing not more than 1.5 per cent oil and not more than 11 per cent moisture, which is substantially free of flammable solvent, is not subject to these Instructions.
≠ A56	This entry applies to articles which contain Class 1 explosive substances and which may also contain dangerous goods of other classes. These articles are used to enhance safety in vehicles, vessels or aircraft (e.g. air bag inflators, air bag modules, seat belt pretensioners and pyromechanical devices). <i>Note.— For the carriage of a vehicle, see Packing Instruction 950, 951 and 952.</i>
A57	Packagings must be so constructed that explosion is not possible by reason of increased internal pressure.
A58	(144) An aqueous solution containing not more than 24 per cent alcohol by volume is not subject to these Instructions.
A59	A tire assembly unserviceable or damaged is not subject to these Instructions if the tire is completely deflated. A tire assembly with a serviceable tire is not subject to these Instructions provided the tire is not inflated to a gauge pressure exceeding the maximum rated pressure for that tire. However, such tires (including valve assemblies) must be protected from damage during transport, which may require the use of a protective cover.
A60	(215) This entry only applies to the technically pure substance or to formulations derived from it having an SADT higher than 75°C and therefore does not apply to formulations which are self-reactive substances. (For self-reactive substances, see 2;4.2.3. Table 2-6). Homogeneous mixtures containing not more than 35 per cent by mass of azocarbonamide and at least 65 per cent of inert substance are not subject to these Instructions unless criteria of other classes or divisions are met.
A61	(168) Asbestos which is immersed or fixed in a natural or artificial binder (such as cement, plastics, asphalt, resins or mineral ore) in such a way that no escape of hazardous quantities of respirable asbestos fibres can occur during transport is not subject to these Instructions. Manufactured articles, containing asbestos and not meeting this requirement, are nevertheless not subject to these Instructions, when packed so that no escape of hazardous quantities of respirable asbestos fibres can occur during transport.

<i>TIs</i>	<i>UN</i>
A62	(178) This designation may only be used when no other appropriate designation exists in the list and then only with the approval of the appropriate authority of the State of Origin.
A63	Not used.
≠ A64	(306) This entry may only be used for substances that are too insensitive for acceptance into Class 1 when tested in accordance with test series 2 (see UN <i>Manual of Tests and Criteria</i> , Part I).
A65	(270) Aqueous solutions of Division 5.1 inorganic solid nitrate substances are considered as not meeting the criteria of Division 5.1 if the concentration of the substances in solution at the minimum temperature encountered in transport is not greater than 80 per cent of the saturation limit.
A66	Polyester resin kits consist of two components: a base material (Class 3, Packing Group II or III) and an activator (Division 5.2). The organic peroxide must be type D, E or F, not requiring temperature control. Packing Group II or III is assigned according to the criteria for Class 3, applies to the base material.
A67	<p>Non-spillable batteries meeting the requirements of Packing Instruction 872 are not subject to these Instructions when carried as cargo if, at a temperature of 55°C, the electrolyte will not flow from a ruptured or cracked case. The battery must not contain any free or unabsorbed liquid. Any electrical battery or battery powered device, equipment or vehicle having the potential of dangerous evolution of heat must be prepared for transport so as to prevent:</p> <p>a) a short circuit (e.g. in the case of batteries, by the effective insulation of exposed terminals; or, in the case of equipment, by disconnection of the battery and protection of exposed terminals); and</p> <p>b) unintentional activation.</p> <p>The words “not restricted” and the special provision number A67 must be provided on the air waybill when an air waybill is issued.</p>
A68	(272) This substance must not be transported under the provisions of Division 4.1 unless specifically authorized by the appropriate national authority. (See UN 0143 or UN 0150 as appropriate.)
≠ A69	<p>The following are not subject to these Instructions when carried as cargo:</p> <p>a) articles other than lamps, such as thermometers, switches and relays, each containing a total quantity of not more than 15 g of mercury, if they are installed as an integral part of a machine or apparatus and so fitted that shock or impact damage, leading to leakage of mercury, is unlikely to occur under normal conditions of transport.</p> <p>b) articles other than lamps, each containing not more than 100 mg of mercury, gallium or inert gas and packaged so that the quantity of mercury, gallium or inert gas per package is 1 g or less.</p> <p>The words “not restricted” and the special provision number A69 must be provided on the air waybill when an air waybill is issued.</p> <p><i>Note.— For lamps containing dangerous goods, see Part 1;2.6.</i></p>
A70	<p>Internal combustion or fuel cell engines being shipped either separately or incorporated into a vehicle, machine or other apparatus, without batteries or other dangerous goods, are not subject to these Instructions when carried as cargo provided that:</p> <p>a) for flammable liquid powered engines:</p> <ol style="list-style-type: none"> 1) the engine is powered by a fuel that does not meet the classification criteria for any class or division; or 2) the fuel tank of the vehicle, machine or other apparatus has never contained any fuel or the fuel tank has been flushed and purged of vapours and adequate measures taken to nullify the hazard; and 3) the entire fuel system of the engine has no free liquid and all fuel lines are sealed or capped or securely connected to the engine and vehicle, machinery or apparatus.

TIs	UN
	<p>b) for flammable gas powered internal combustion or fuel cell engines:</p> <ol style="list-style-type: none"> 1) the entire fuel system must have been flushed, purged and filled with a non-flammable gas or fluid to nullify the hazard; 2) the final pressure of the non-flammable gas used to fill the system does not exceed 200 kPa at 20°C; 3) the shipper has made prior arrangements with the operator; and 4) the shipper has provided the operator with written or electronic documentation stating that the flushing, purging and filling procedure has been followed and that the final contents of the engine(s) have been tested and verified to be non-flammable. <p>Multiple engines may be shipped in a unit load device or other type of pallet provided that the shipper has made prior arrangements with the operator(s) for each shipment.</p> <p>When this special provision is used, the words “not restricted” and the special provision number A70 must be provided on the air waybill when an air waybill is issued.</p>
A71	(38) This substance is not subject to these Instructions when it contains not more than 0.1 per cent calcium carbide.
A72	(163) A substance specifically listed by name in Table 3-1 must not be transported under this entry. Materials transported under this entry may contain 20 per cent or less nitrocellulose provided the nitrocellulose contains not more than 12.6 per cent nitrogen.
A73	(237) The membrane filters, including paper separators, coating, or backing materials, etc., that are present in transport, must not be liable to propagate a detonation as tested by one of the tests described in the UN <i>Manual of Tests and Criteria</i> , Part I, Test Series 1(a).
	In addition, the appropriate authority may determine, on the basis of the results of suitable burning rate tests taking account of the standard tests in the UN <i>Manual of Tests and Criteria</i> , Part III, subsection 33.2.1, that nitrocellulose membrane filters in the form in which they are to be transported are not subject to the provisions of these Instructions applicable to flammable solids in Division 4.1.
A74	(169) Phthalic anhydride in the solid state and tetrahydrophthalic anhydrides, with not more than 0.05 per cent maleic anhydride, are not subject to these Instructions. Phthalic anhydride molten at a temperature above its flash point, with not more than 0.05 per cent maleic anhydride, must be classified under UN 3256.
≠	A75 Articles such as sterilization devices, when containing less than 30 mL per inner packaging with not more than 150 mL per outer packaging, may be transported on passenger and cargo aircraft in accordance with the provisions in 3;5, irrespective of the indication of “forbidden” in columns 10 to 13 of Table 3-1, provided such packagings were first subjected to comparative fire testing. Comparative fire testing between a package as prepared for transport (including the substance to be transported) and an identical package filled with water must show that the maximum temperature measured inside the packages during testing does not differ by more than 200°C. Packagings may include a vent to permit the slow escape of gas (i.e. not more than 0.1 mL/hour per 30 mL inner packaging at 20°C) produced from gradual decomposition.
+	The requirements of 4;1.1.6, 4;1.1.12 and 4;7.1.2 do not apply.
A76	(326) In the case of fissile uranium hexafluoride, the material must be classified under UN 2977.
A77	Mixtures of solids which are not subject to these Instructions and corrosive liquids may be transported under this entry without first applying the classification criteria of Class 8, providing there is no free liquid visible at the time the substance is packaged and, for single packagings, the packaging must pass a leakproofness test at the Packing Group II level.
≠	A78 Where a radioactive material has a subsidiary risk(s):
≠	a) The substance must be allocated to Packing Group I, II or III, if appropriate, by application of the packing group criteria provided in Part 2 corresponding to the nature of the predominant subsidiary risk.
≠	b) Packages must be labelled with subsidiary risk labels corresponding to each subsidiary risk exhibited by the material in accordance with the relevant provisions of 5;3.2; corresponding placards must be affixed to cargo transport units in accordance with the relevant provisions of 5;3.6.

<i>TIs</i>	<i>UN</i>
+	c) For the purposes of documentation and package marking, the proper shipping name must be supplemented with the name of the constituents which most predominantly contribute to this subsidiary risk(s) and which must be enclosed in parenthesis.
+	d) The dangerous goods transport document must indicate the subsidiary class or division and, where assigned, the packing group as required by 5;4.1.4.1 d) and e).
+	For packing, see also 4;9.1.5.
>	Radioactive material with a subsidiary risk of Division 4.2 (Packing Group I) must be transported in Type B packages. Radioactive material with a subsidiary risk of Division 2.1 is forbidden from transport on passenger aircraft, and radioactive material with a subsidiary risk of Division 2.3 is forbidden from transport on passenger or cargo aircraft except with the prior approval of the appropriate authority of the State of Origin and the State of the Operator under the conditions established by those authorities. A copy of the document of approval, showing the quantity limitations and the packaging requirements, must accompany the consignment.
A79	(307) This entry may only be used for uniform mixtures containing ammonium nitrate as the main ingredient within the following composition limits: <ul style="list-style-type: none"> a) not less than 90 per cent ammonium nitrate with not more than 0.2 per cent total combustible/organic material calculated as carbon and with added matter, if any, which is inorganic and inert towards ammonium nitrate; or b) less than 90 per cent but more than 70 per cent ammonium nitrate with other inorganic materials or more than 80 per cent but less than 90 per cent ammonium nitrate mixed with calcium carbonate and/or dolomite and/or mineral calcium sulphate and not more than 0.4 per cent total combustible/organic material calculated as carbon; or c) nitrogen type ammonium nitrate based fertilizers containing mixtures of ammonium nitrate and ammonium sulphate with more than 45 per cent but less than 70 per cent ammonium nitrate and not more than 0.4 per cent total combustible/organic material calculated as carbon such that the sum of the percentage composition of ammonium nitrate and ammonium sulphate exceeds 70 per cent.
A80	(220) The technical name of the flammable liquid component only of this solution or mixture must be shown in parenthesis immediately following the proper shipping name.
A81	The quantity limits shown in columns 11 and 13 do not apply to body parts, organs or whole bodies.
A82	(177) Barium sulphate is not subject to these Instructions.
A83	(208) The commercial grade of calcium nitrate fertilizer, when consisting mainly of a double salt (calcium nitrate and ammonium nitrate) containing not more than 10 per cent ammonium nitrate and at least 12 per cent water of crystallization, is not subject to these Instructions.
A84	(182) The group of alkali metals includes lithium, sodium, potassium, rubidium and caesium.
A85	(183) The group of alkaline earth metals includes magnesium, calcium, strontium and barium.
A86	(241) The formulation must be prepared so that it remains homogeneous and does not separate during transport. Formulations with low nitrocellulose contents are not subject to these Instructions provided that 1) they do not exhibit dangerous properties when tested for their liability to detonate, deflagrate or explode when heated under defined confinement by tests of test series 1(a), 2(b) and 2(c) respectively in the UN <i>Manual of Tests and Criteria</i> and 2) they are not flammable solids when tested in accordance with test N1 in the UN <i>Manual of Tests and Criteria</i> , Part III, subsection 3.3.2.1.4 (chips, if necessary, crushed and sieved to a particle size of less than 1.25 mm).
A87	Articles which are not fully enclosed by packaging, crates or other means that prevent ready identification are not subject to the marking requirements of 5;2 or the labelling requirements of 5;3.
A88	Prototype or low production (i.e., annual production runs consisting of not more than 100 lithium batteries or cells) lithium batteries or cells that have not been tested to the requirements in subsection 38.3 of the UN <i>Manual of Tests and Criteria</i> may be transported aboard cargo aircraft if approved by the appropriate authority of the State of Origin and the following requirements are met: <ul style="list-style-type: none"> a) except as provided in paragraph c), cells or batteries must be transported in an outer packaging that is a metal, plastic or plywood drum or a metal, plastic or wooden box and that meets the criteria for Packing Group I packagings;

TIs UN

- b) except as provided in paragraph c), each cell or battery must be individually packed in an inner packaging inside an outer packaging and surrounded by cushioning material that is non-combustible, and non-conductive. Cells or batteries must be protected against short circuiting;
- c) lithium batteries with a mass of 12 kg or greater and having a strong, impact resistant outer casing, or assemblies of such batteries, may be packed in strong outer packagings or protective enclosures not subject to the requirements of Part 6 of these Instructions. The batteries or battery assemblies must be protected against short circuiting; and
- d) a copy of the document of approval showing the quantity limitations must accompany the consignment.

Irrespective of the limit specified in column 13 of Table 3-1, the battery or battery assembly as prepared for transport may have a mass exceeding 35 kg G.

- A89 (186) In determining the ammonium nitrate content, all nitrate ions for which a molecular equivalent of ammonium ions is present in the mixture must be calculated as ammonium nitrate.
- A90 (193) This entry may only be used for uniform ammonium nitrate based fertilizer mixtures of the nitrogen, phosphate or potash type, containing not more than 70 per cent ammonium nitrate and not more than 0.4 per cent total combustible/organic material calculated as carbon or with not more than 45 per cent ammonium nitrate and unrestricted combustible material. Fertilizers within these composition limits are not subject to these Instructions if shown by a Trough Test (see UN *Manual of Tests and Criteria*, Part III, subsection 38.2) not to be liable to self-sustaining decomposition.
- A91 (198) A nitrocellulose solution containing not more than 20 per cent nitrocellulose may be transported under the requirements for "Paint", "Perfumery products" or "Printing ink" as applicable; see UN 1210, UN 1263, UN 1266, UN 3066, UN 3469 and UN 3470.
- A92 (199) Lead compounds which, when mixed in a ratio of 1:1000 with 0.07 M hydrochloric acid and stirred for 1 hour at a temperature of 23°C ±2°C, exhibit a solubility of 5 per cent or less (see ISO 3711:1990 "*Lead chromate pigments and lead chromate-molybdate pigments — Specifications and methods of test*") are considered insoluble and are not subject to these Instructions unless they meet the criteria for inclusion in another hazard class or division.
- A93 A heat-producing article is not subject to these Instructions when the heat-producing component or the energy source is removed to prevent unintentional functioning during transport. The words "not restricted" and the special provision number A93 must be provided on the air waybill when an air waybill is issued.
- A94 Batteries or cells containing sodium must not contain dangerous goods other than sodium, sulphur or sodium compounds (e.g. sodium polysulphides and sodium tetrachloroaluminate). Batteries or cells must not be offered for transport at a temperature such that liquid elemental sodium is present in the battery or cell unless approved and under the conditions established by the appropriate national authority.
- Cells must consist of hermetically sealed metal casings which fully enclose the dangerous goods and which are so constructed and closed as to prevent the release of the dangerous goods under normal conditions of transport.
- Batteries must consist of cells secured within and fully enclosed by a metal casing so constructed and closed as to prevent the release of the dangerous goods under normal conditions of transport.
- A95 (203) This entry is not to be used for Polychlorinated biphenyls (UN 2315).
- A96 (196) Only formulations which in laboratory testing neither detonate in the cavitated state nor deflagrate, which show no effect when heated under confinement and which exhibit no explosive power may be transported under this entry. The formulation must also be thermally stable (i.e. the SADT is 60°C or higher for a 50 kg package). Formulations not meeting these criteria must be transported under the appropriate provisions of Division 5.2.
- A97 These entries must be used for substances which are hazardous to the environment but do not meet the classification criteria of any other class or other substance within Class 9. This must be based on the criteria as indicated in 2;9.2.1 a). This designation may also be used for wastes not otherwise subject to these Instructions but which are covered under the *Basel Convention on the Control of Transboundary Movements of Hazardous Wastes and their Disposal*.

<i>TIs</i>	<i>UN</i>
A98	Aerosols, gas cartridges and receptacles, small, containing gas with a capacity not exceeding 50 ml, containing no constituents subject to these Instructions other than a Division 2.2 gas, are not subject to these Instructions when carried as cargo unless their release could cause extreme annoyance or discomfort to crew members so as to prevent the correct performance of assigned duties. The words "not restricted" and the special provision number A98 must be provided on the air waybill when an air waybill is issued.
A99	Irrespective of the quantity limits for cargo aircraft specified in column 13 of Table 3-1, and in Section I of Packing Instructions 965, 966, 967, 968, 969 and 970, a lithium battery or battery assembly (i.e. UN 3090 or UN 3480), including when packed with equipment or contained in equipment (i.e. UN 3091 or UN 3481) that meets the other requirements of Section I of the applicable packing instruction, may have a mass exceeding 35 kg, if approved by the appropriate authority of the State of Origin. A copy of the document of approval must accompany the consignment.
A100	(243) Gasoline, motor spirit and petrol for use in spark-ignition engines (e.g. in automobiles, stationary engines and other engines) must be assigned to this entry regardless of variations in volatility.
A101	(227) When phlegmatized with water and inorganic inert material, the content of urea nitrate may not exceed 75 per cent by mass and the mixture must not be capable of being detonated by the series 1 type (a) test in the <i>UN Manual of Tests and Criteria</i> , Part I.
A102	(244) This listing includes aluminium dross, aluminium skimmings, spent cathodes, spent potliner and aluminium salt slags.
A103	Flammable liquefied gases must be contained within refrigerating machine components. These components must be designed and tested to at least three times the working pressure of the machinery. The refrigerating machines must be designed and constructed to contain the liquefied gas and preclude the risk of bursting or cracking of the pressure-retaining components during normal conditions of transport. Refrigerating machines and refrigerating machine components are considered not subject to these Instructions if containing less than 100 g flammable, non-toxic, liquefied gas.
A104	A toxic subsidiary risk label, although not required by these Instructions, may be applied.
A105	(242) Sulphur is not subject to these Instructions when it has been formed to a specific shape (e.g. prills, granules, pellets, pastilles or flakes).
A106	This entry may only be used for samples of chemicals taken for analysis in connection with the implementation of the Chemical Weapons Convention. They may be transported on a passenger or cargo aircraft providing prior approval has been granted by the appropriate authority of the State of Origin or the Director General of the Organization for the Prohibition of Chemical Weapons and providing the samples comply with the requirements shown against the entry for chemical samples in Table S-3-1 of the Supplement. The substance is assumed to meet the criteria of Packing Group I for Division 6.1. Subsidiary risk labelling is not required. A copy of the document of approval showing the quantity limitations and the packing requirements must accompany the consignment. <i>Note.— The transport of substances under this description must be in accordance with chain of custody and security procedures specified by the Organization for the Prohibition of Chemical Weapons.</i>
A107	This entry only applies to machinery or apparatus containing dangerous goods as a residue or as an integral element of the machinery or apparatus. It must not be used for machinery or apparatus for which a proper shipping name already exists in Table 3-1.
A108	The provisions of Special Provision A1 apply to this entry for Packing Group I only.
A109	Not used.
A110	(226) Formulations of these substances containing not less than 30 per cent non-volatile, non-flammable phlegmatizer are not subject to these Instructions.
A111	Oxygen generators, chemical, that have passed their expiration date, are unserviceable or that have been used are forbidden for transport.

<i>TIs</i>	<i>UN</i>
A112	Consumer commodities may only include substances of Class 2 (non-toxic aerosols only), Class 3, Packing Group II or III, Division 6.1 (Packing Group III only), UN 3077, UN 3082 and UN 3175, provided such substances do not have a subsidiary risk. Dangerous goods that are forbidden for transport aboard passenger aircraft must not be transported as consumer commodities.
A113	(279) The substance is assigned to this classification or Packing Group based on human experience rather than the strict application of classification criteria set out in the Instructions.
A114	(283) Articles, containing gas, intended to function as shock absorbers, including impact energy absorbing devices, or pneumatic springs are not subject to these Instructions provided: <ul style="list-style-type: none"> a) each article has a gas space capacity not exceeding 1.6 litres and a charge pressure not exceeding 280 bar where the product of the capacity (litres) and charge pressure (bars) does not exceed 80 (i.e. 0.5 litre gas space and 160 bar charge pressure, 1 litre gas space and 80 bar charge pressure, 1.6 litre gas space and 50 bar charge pressure, 0.28 litre gas space and 280 bar charge pressure); b) each article has a minimum burst pressure of 4 times the charge pressure at 20°C for products not exceeding 0.5 litre gas space capacity and 5 times charge pressure for products greater than 0.5 litre gas space capacity; c) each article is manufactured from material which will not fragment upon rupture; d) each article is manufactured in accordance with a quality assurance standard acceptable to the appropriate national authority; and e) the design type has been subjected to a fire test demonstrating that pressure in the article is relieved by means of a fire-degradable seal or other pressure-relief device such that the article will not fragment and the article does not rocket.
≠	A115 (280) This entry applies to safety devices for vehicles, vessels or aircraft, e.g. air bag inflators, air bag modules, seat belt pretensioners, and pyromechanical devices and which contain dangerous goods of Class 1 or dangerous goods of other classes and when transported as component parts and if these articles as presented for transport have been tested in accordance with test series 6 (c) of Part I of the UN <i>Manual of Tests and Criteria</i> , with no explosion of the device, no fragmentation of the device casing or pressure receptacle, and no projection hazard or thermal effect which would significantly hinder firefighting or other emergency response efforts in the immediate vicinity.
+	This entry does not apply to life saving appliances described in Packing Instruction 955 (UN Nos. 2990 and 3072).
A116	An oxygen generator, chemical, when containing an explosive actuating device must only be transported under this entry when excluded from Class 1 in accordance with 2;1.1 b).
A117	Wastes containing Category A infectious substances must be assigned to UN 2814 or UN 2900. Wastes transported under UN 3291 are wastes containing infectious substances in Category B or wastes that are reasonably believed to have a low probability of containing infectious substances. Decontaminated wastes which previously contained infectious substances may be considered as not subject to these Instructions unless the criteria of another class or division are met.
A118	Items classified as explosive must be removed from vehicles and transported in accordance with the provisions of these Instructions unless authorized by the appropriate national authority under the written conditions established by that authority. In such circumstances, vehicles may be transported on cargo aircraft only. <p><i>Note.— This special provision does not apply where the explosives are a smoke candle installed as a permanent part of the vehicle or are part of an assembly classified as dangerous goods of other than Class 1, e.g. Air bag inflators, Air bag modules and Seat-belt pretensioners (UN 3268), Fire extinguishers (UN 1044). Additionally, this special provision does not apply in the case of Air bag modules and Air bag inflators and Seat-belt pretensioners (UN 0503) installed in the vehicle.</i></p>
A119	Irrespective of the limit specified in column 13 of Table 3-1, a handling device meeting the requirements of Packing Instruction 961 as prepared for transport may have a gross mass not exceeding 1 000 kg.
A120	This entry includes but is not limited to automobiles, motorcycles, aircraft, boats, snowmobiles, jet skis, etc.
A121	Not used.
A122	(286) Nitrocellulose membrane filters covered by this entry, each with a mass not exceeding 0.5 g, are not subject to these Instructions when contained individually in an article or a sealed packet.

<i>TIs</i>	<i>UN</i>	
≠ A123		<p>This entry applies to Batteries, electric storage, not otherwise listed in Table 3-1. Examples of such batteries are: alkali-manganese, zinc-carbon and nickel-cadmium batteries. Any electrical battery or battery-powered device, equipment or vehicle having the potential of a dangerous evolution of heat must be prepared for transport so as to prevent:</p> <ul style="list-style-type: none"> a) a short circuit (e.g. in the case of batteries, by the effective insulation of exposed terminals; or, in the case of equipment, by disconnection of the battery and protection of exposed terminals); and b) unintentional activation. <p>The words "not restricted" and the special provision number A123 must be provided on the air waybill when an air waybill is issued.</p>
A124	(292)	Not used.
A125	(293)	<p>The following definitions apply to matches:</p> <ul style="list-style-type: none"> a) Fusee matches are matches the heads of which are prepared with a friction-sensitive igniter composition and a pyrotechnic composition which burns with little or no flame, but with intense heat; b) Safety matches are combined with or attached to the box, book or card that can be ignited by friction only on a prepared surface; c) Strike anywhere matches are matches that can be ignited by friction on a solid surface; d) Wax Vesta matches are matches that can be ignited by friction either on a prepared surface or on a solid surface.
A126		Not used.
A127		Not used.
A128	(153)	This entry only applies if it is demonstrated, on the basis of tests, that the substances, when in contact with water are not combustible nor show a tendency to auto-ignition and that the mixture of gases evolved is not flammable.
A129	(252)	Provided the ammonium nitrate remains in solution under all conditions of transport, aqueous solutions of ammonium nitrate, with not more than 0.2 per cent combustible material, in a concentration not exceeding 80 per cent are not subject to these Instructions when carried as cargo.
A130	(290)	<p>When this radioactive material meets the definitions and criteria of other classes or divisions as defined in Part 2, it must be classified in accordance with the following:</p> <ul style="list-style-type: none"> a) Where the substance meets the criteria for dangerous goods in excepted quantities as set out in 3;5, the packagings must be in accordance with 3;5.2 and meet the testing requirements of 3;5.3. All other requirements applicable to radioactive material, excepted packages as set out in 1;6.1.5 apply without reference to the other class or division; b) Where the quantity exceeds the limits specified in 3;5.1.2, the substance must be classified in accordance with the predominant subsidiary risk. The dangerous goods transport document must describe the substance with the proper shipping name and UN number applicable to the other class supplemented with the name applicable to the radioactive excepted package according to column 1 of the Dangerous Goods List, and must be transported in accordance with the provisions applicable to that UN number. An example of the information shown on the dangerous goods transport document is: <ul style="list-style-type: none"> UN 1993 Flammable liquid, n.o.s. (ethanol and toluene mixture), Radioactive material, excepted package — limited quantity of material, Class 3, PG II <p>The radioactive material, excepted package label (Figure 5-30) is not required on packages meeting the conditions set out in this sub-paragraph. To aid acceptance, it is recommended that "A130" be indicated on the dangerous goods transport document. In addition, the requirements of 2;7.2.4.1.1 apply;</p> c) The provisions of 3;4 for the transport of dangerous goods packed in limited quantities do not apply to substances classified in accordance with sub-paragraph b); d) When the substance meets a special provision that exempts this substance from all dangerous goods provisions of the other classes, it must be classified in accordance with the applicable UN number of Class 7 and all requirements specified in 1;6.1.5 apply.

<i>TIs</i>	<i>UN</i>	
≠ A131	(342)	Glass inner receptacles (such as ampoules or capsules) intended only for use in sterilization devices, when containing less than 30 mL of ethylene oxide per inner packaging with not more than 300 mL per outer packaging, may be transported in accordance with the provisions in 3;5, irrespective of the indication of "forbidden" in columns 10 to 13 of Table 3-1, provided that: <ul style="list-style-type: none"> a) after filling, each glass inner receptacle has been determined to be leak-tight by placing the glass inner receptacle in a hot water bath at a temperature, and for a period of time, sufficient to ensure that an internal pressure equal to the vapour pressure of ethylene oxide at 55°C is achieved. Any glass inner receptacle showing evidence of leakage, distortion or other defect under this test must not be transported under the terms of this special provision; b) in addition to the packaging required by 3;5.2, each glass inner receptacle is placed in a sealed plastic bag compatible with ethylene oxide and capable of containing the contents in the event of breakage or leakage of the glass inner receptacle; and c) each glass inner receptacle is protected by a means of preventing puncture of the plastic bag (e.g. sleeves or cushioning) in the event of damage to the packaging (e.g. by crushing).
A132	(204)	Articles containing smoke-producing substance(s) corrosive according to the criteria for Class 8 must be labelled with a "Corrosive" subsidiary risk label.
A133	(311)	Substances must not be transported under this entry unless approved by the appropriate national authority on the basis of the results of appropriate tests according to Part I of the UN <i>Manual of Tests and Criteria</i> . Packaging must ensure that the percentage of diluent does not fall below that stated in the appropriate authority approval at any time during transport.
A134	(312)	Vehicles or machinery powered by a fuel cell engine must be consigned under the entries UN 3166 Vehicle, fuel cell, flammable gas powered or UN 3166 Vehicle, fuel cell, flammable liquid powered , or UN 3166 Engine, fuel cell, flammable gas powered or UN 3166 Engine, fuel cell, flammable liquid powered , as appropriate. These entries include hybrid electric vehicles powered by both a fuel cell and an internal combustion engine with wet batteries, sodium batteries, lithium metal batteries or lithium ion batteries, transported with the battery(ies) installed. Other vehicles which contain an internal combustion engine must be consigned under the entries UN 3166 Vehicle, flammable gas powered or UN 3166 Vehicle, flammable liquid powered , as appropriate. These entries include hybrid electric vehicles powered by both an internal combustion engine and wet batteries, sodium batteries, lithium metal batteries or lithium ion batteries, transported with the battery(ies) installed.
A135	(313)	Not used.
A136	(314)	<ul style="list-style-type: none"> a) These substances are liable to exothermic decomposition at elevated temperatures. Decomposition can be initiated by heat or by impurities (e.g. powdered metals (iron, manganese, cobalt, magnesium) and their compounds). b) During the course of transport, these substances must be shaded from direct sunlight and all sources of heat and be placed in adequately ventilated areas.
A137	(315)	This entry must not be used for Division 6.1 substances that meet the inhalation toxicity criteria for Packing Group I described in 2;6.2.2.4.3.
A138	(316)	This entry applies only to calcium hypochlorite, dry, when transported in non-friable tablet form.
A139	(317)	"Fissile-excepted" applies only to those packages complying with 6;7.10.2.
A140	(318)	For the purposes of documentation, the proper shipping name must be supplemented with the technical name (see 1.2.7). Technical names need not be shown on the package. When the infectious substances to be transported are unknown, but suspected of meeting the criteria for inclusion in category A and assignment to UN 2814 or UN 2900, the words "suspected category A infectious substance" must be shown, in parentheses, following the proper shipping name on the transport document, but not on the outer packagings.
A141		Not used.
A142		Not used.
A143	(321)	These storage systems must always be considered as containing hydrogen.

<i>TIs</i>	<i>UN</i>
A144	<p>Protective breathing equipment (PBE) containing a small chemical oxygen generator for use by aircrew members may be transported on passenger aircraft in accordance with Packing Instruction 565 subject to the following conditions:</p> <ol style="list-style-type: none"> a) the PBE must be serviceable and contained in the manufacturer's original unopened inner packaging (i.e. vacuum sealed bag and protective container); b) the PBE may only be consigned by, or on behalf of, an operator in the event that a PBE(s) has been rendered unserviceable or has been used and there is a need to replace such items so as to restore the number of PBEs on an aircraft to that required by pertinent airworthiness requirements and operating regulations; c) a maximum of two PBE may be contained in a package; d) the statement "Aircrew protective breathing equipment (smoke hood) in accordance with Special Provision A144" must be: <ol style="list-style-type: none"> (i) included on the dangerous goods transport document; (ii) marked adjacent to the proper shipping name on the package. <p>If the above conditions are met, the requirements of Special Provision A1 do not apply. All other requirements applicable to chemical oxygen generators must apply except that the "cargo aircraft only" handling label must not be displayed.</p>
A145	Waste aerosols are forbidden from air transport.
A146	<p>(328) This entry applies to fuel cell cartridges including when contained in equipment or packed with equipment. Fuel cell cartridges installed in or integral to a fuel cell system are regarded as contained in equipment. Fuel cell cartridge means an article that stores fuel for discharge into the fuel cell through a valve(s) that controls the discharge of fuel into the fuel cell. Fuel cell cartridges, including when contained in equipment, must be designed and constructed to prevent fuel leakage under normal conditions of transport.</p> <p>Fuel cell cartridge design types using liquids as fuels must pass an internal pressure test at a pressure of 100 kPa (gauge) without leakage.</p> <p>Except for fuel cell cartridges containing hydrogen in metal hydride which must be in compliance with A162, each fuel cell cartridge design type, including fuel cell cartridges installed in or integral to a fuel cell system, must be shown to pass a 1.2 metre drop test onto an unyielding surface in the orientation most likely to result in failure of the containment system with no loss of contents.</p> <p>When lithium metal batteries or lithium ion batteries are contained in the fuel cell system, the consignment must be consigned under this entry and under the appropriate entries for UN 3091 Lithium metal batteries contained in equipment or UN 3481 Lithium ion batteries contained in equipment.</p>
A147	(329) Not used.
A148	(330) Not used.
A149	Not used.
A150	An additional subsidiary risk hazard label may be required by a Note found adjacent to the technical name entry in Table 2-7.
A151	When dry ice is used as a refrigerant for other than dangerous goods loaded in a unit load device or other type of pallet, the quantity limits per package shown in columns 11 and 13 of Table 3-1 for dry ice do not apply. In such case, the unit load device or other type of pallet must be identified to the operator and must allow the venting of the carbon dioxide gas to prevent a dangerous build-up of pressure.
A152	Insulated packagings conforming to the requirements of Packing Instruction 202 containing refrigerated liquid nitrogen fully absorbed in a porous material are not subject to these Instructions provided the design of the insulated packaging would not allow the build-up of pressure within the container and would not permit the release of any refrigerated liquid nitrogen irrespective of the orientation of the insulated packaging and any outer packaging or overpack used is closed in a way that will not allow the build-up of pressure within that packaging or overpack. When used to contain substances not subject to these Instructions, the words "not restricted" and the special provision number A152 must be provided on the air waybill when an air waybill is issued.
A153	Not used.

<i>TIs</i>	<i>UN</i>
A154	Lithium batteries, identified by the manufacturer as being defective for safety reasons, or that have been damaged, that have the potential of producing a dangerous evolution of heat, fire or short circuit are forbidden for transport (e.g. those being returned to the manufacturer for safety reasons).
A155	(332) Magnesium nitrate hexahydrate is not subject to these Instructions.
A156	(333) Ethanol and gasoline, motor spirit or petrol mixtures for use in spark-ignition engines (e.g. in automobiles, stationary engines and other engines) must be assigned to this entry regardless of variations in volatility.
A157	(334) A fuel cell cartridge may contain an activator provided it is fitted with two independent means of preventing unintended mixing with the fuel during transport.
A158	(335) Mixtures of solids which are not subject to these Instructions and liquids or solids classified by the shipper as environmentally hazardous substances (UN 3077 and 3082) (see Special Provision A97) may be transported under this entry, provided there is no free liquid visible at the time the substance is loaded or at the time the packaging is closed. Sealed packets and articles containing less than 10 mL of an environmentally hazardous liquid, absorbed into a solid material but with no free liquid in the packet or article, or containing less than 10 g of an environmentally hazardous solid, are not subject to these Instructions.
A159	(336) A single package of non-combustible solid LSA-II or LSA-III material must not contain an activity greater than 3000 A ₂ .
A160	(337) Type B(U) and Type B(M) packages, must not contain activities greater than the following: <ul style="list-style-type: none"> a) For low dispersible radioactive material: as authorized for the package design as specified in the certificate of approval; b) For special form radioactive material: 3000 A₁ or 100 000 A₂, whichever is the lower; or c) For all other radioactive material: 3000 A₂.
A161	(338) Each fuel cell cartridge transported under this entry and designed to contain a liquefied flammable gas must: <ul style="list-style-type: none"> a) be capable of withstanding, without leakage or bursting, a pressure of at least two (2) times the equilibrium pressure of the contents at 55°C; b) not contain more than 200 mL liquefied flammable gas, the vapour pressure of which must not exceed 1 000 kPa at 55°C; and c) pass the hot water bath test prescribed in 6;5.4.1.
A162	(339) Fuel cell cartridges containing hydrogen in a metal hydride transported under this entry must have a water capacity less than or equal to 120 mL. The pressure in the fuel cell cartridge must not exceed 5 MPa at 55°C. The design type must withstand, without leaking or bursting, a pressure of two (2) times the design pressure of the cartridge at 55°C or 200 kPa more than the design pressure of the cartridge at 55°C, whichever is greater. The pressure at which this test is conducted is referred to in the drop test and the hydrogen cycling test as the "minimum shell burst pressure". Fuel cell cartridges must be filled in accordance with procedures provided by the manufacturer. The manufacturer must provide the following information with each fuel cell cartridge: <ul style="list-style-type: none"> a) inspection procedures to be carried out before initial filling and before refilling of the fuel cell cartridge; b) safety precautions and potential hazards to be aware of; c) method for determining when the rated capacity has been achieved; d) minimum and maximum pressure range; e) minimum and maximum temperature range; and f) any other requirements to be met for initial filling and refilling including the type of equipment to be used for initial filling and refilling.

TIs UN

The fuel cell cartridges must be designed and constructed to prevent fuel leakage under normal conditions of transport. Each cartridge design type, including cartridges integral to a fuel cell, must be subjected to and must pass the following tests:

Drop test

A 1.8 metre drop test onto an unyielding surface in four different orientations:

- a) vertically, on the end containing the shut-off valve assembly;
- b) vertically, on the end opposite to the shut-off valve assembly;
- c) horizontally, onto a steel apex with a diameter of 38 mm, with the steel apex in the upward position; and
- d) at a 45° angle on the end containing the shut-off valve assembly.

There must be no leakage, determined by using a soap bubble solution or other equivalent means on all possible leak locations, when the cartridge is charged to its rated charging pressure. The fuel cell cartridge must then be hydrostatically pressurized to destruction. The recorded burst pressure must exceed 85 per cent of the minimum shell burst pressure.

Fire test

A fuel cell cartridge filled to rated capacity with hydrogen must be subjected to a fire engulfment test. The cartridge design, which may include a vent feature integral to it, is deemed to have passed the fire test if:

- a) the internal pressure vents to zero gauge pressure without rupture of the cartridge; or
- b) the cartridge withstands the fire for a minimum of 20 minutes without rupture.

Hydrogen cycling test

This test is intended to ensure that a fuel cell cartridge design stress limits are not exceeded during use.

The fuel cell cartridge must be cycled from not more than 5 per cent rated hydrogen capacity to not less than 95 per cent rated hydrogen capacity and back to not more than 5 per cent rated hydrogen capacity. The rated charging pressure must be used for charging and temperatures must be held within the operating temperature range. The cycling must be continued for at least 100 cycles.

Following the cycling test, the fuel cell cartridge must be charged and the water volume displaced by the cartridge must be measured. The cartridge design is deemed to have passed the hydrogen cycling test if the water volume displaced by the cycled cartridge does not exceed the water volume displaced by an uncycled cartridge charged to 95 per cent rated capacity and pressurized to 75 per cent of its minimum shell burst pressure.

Production leak test

Each fuel cell cartridge must be tested for leaks at 15°C ± 5°C, while pressurized to its rated charging pressure. There must be no leakage, determined by using a soap bubble solution or other equivalent means on all possible leak locations.

Each fuel cell cartridge must be permanently marked with the following information:

- a) the rated charging pressure in megapascals (MPa);
- b) the manufacturer's serial number of the fuel cell cartridges or unique identification number; and
- c) the date of expiry based on the maximum service life (year in four digits; month in two digits).

- A163 (340) Chemical kits, first-aid kits and polyester resin kits containing dangerous goods in inner packagings which do not exceed the quantity limits for excepted quantities applicable to individual substances as specified in column 9 of Table 3-1 may be transported in accordance with 3;5. Division 5.2 substances, although not individually permitted as excepted quantities in Table 3-1, are permitted in such kits and are assigned Code E2 (see 5.1.2).

<i>TIs</i>	<i>UN</i>
A164	Any electrical battery or battery-powered device, equipment or vehicle having the potential of a dangerous evolution of heat must be prepared for transport so as to prevent: <ul style="list-style-type: none"> a) a short circuit (e.g. in the case of batteries, by the effective insulation of exposed terminals; or, in the case of equipment, by disconnection of the battery and protection of exposed terminals); and b) unintentional activation.
A165	(347) This entry may only be used if the results of Test Series 6 (d) of Part I of the UN <i>Manual of Tests and Criteria</i> have demonstrated that any hazardous effects arising from functioning are confined within the package (see 2;1.4.2.1).
A166	(343) This entry applies to crude oil containing hydrogen sulphide in sufficient concentration that vapours evolved from the crude oil can present an inhalation hazard. The packing group assigned must be determined by the flammability hazard and inhalation hazard, in accordance with the degree of danger presented.
A167	(344) The provisions of 6;5.4 must be met.
A168	(348) Not used. <i>Note.— See Packing Instructions 965 to 967.</i>
A169	(349) Mixtures of a hypochlorite with an ammonium salt are not to be accepted for transport. UN 1791 Hypochlorite solution is a substance of Class 8.
A170	(350) Ammonium bromate and its aqueous solutions and mixtures of a bromate with an ammonium salt are forbidden for transport.
A171	(351) Ammonium chlorate and its aqueous solutions and mixtures of a chlorate with an ammonium salt are forbidden for transport.
A172	(352) Ammonium chlorite and its aqueous solutions and mixtures of a chlorite with an ammonium salt are forbidden for transport.
A173	(353) Ammonium permanganate and its aqueous solutions and mixtures of a permanganate with an ammonium salt are forbidden for transport.
A174	(354) Not used.
A175	(355) Oxygen cylinders for emergency use transported under this entry may include installed actuating cartridges (cartridges, power device of Division 1.4, Compatibility Group C or S), without changing the classification of Division 2.2 provided the total quantity of deflagrating (propellant) explosives does not exceed 3.2 g per oxygen cylinder. The cylinders with the installed actuating cartridges as prepared for transport must have an effective means of preventing inadvertent activation.
A176	(356) Metal hydride storage systems installed in vehicles, vessels or aircraft or in completed components or intended to be installed in vehicles, vessels or aircraft must be approved by the appropriate national authority before acceptance for transport. The dangerous goods transport document must include an indication that the package was approved by the appropriate national authority or a copy of the appropriate national authority approval must accompany each consignment.
A177	(357) Petroleum crude oil containing hydrogen sulphide in sufficient concentration that vapours evolved from the crude oil can present an inhalation hazard must be consigned under the entry UN 3494 Petroleum sour crude oil, flammable, toxic .
A178	Security type equipment such as attaché cases, cash boxes, cash bags, etc., incorporating dangerous goods, for example lithium batteries, gas cartridges and/or pyrotechnic material, are not subject to these instructions if the equipment complies with the following: <ul style="list-style-type: none"> a) The equipment must be equipped with an effective means of preventing accidental activation; b) If the equipment contains an explosive or pyrotechnic substance or an explosive article, this article or substance must be excluded from Class 1 by the appropriate national authority of the State of Manufacture in compliance with Part 2;1.5.2.1; c) If the equipment contains lithium cells or batteries, these cells or batteries must comply with the following restrictions:

<i>TIs</i>	<i>UN</i>
	<ol style="list-style-type: none"> 1) for a lithium metal cell, the lithium content is not more than 1 g; 2) for a lithium metal or lithium alloy battery, the aggregate lithium content is not more than 2 g; 3) for lithium ion cells, the Watt-hour rating (see Attachment 2) is not more than 20 Wh; 4) for lithium ion batteries, the Watt-hour rating is not more than 100 Wh; 5) each cell or battery is of the type proven to meet the requirements of each test in the UN <i>Manual of Tests and Criteria</i>, Part III, section 38.3; <p>d) If the equipment contains gases to expel dye or ink, only gas cartridges and receptacles, small, containing gas with a capacity not exceeding 50 mL, containing no constituents subject to these Instructions other than a Division 2.2 gas, are allowed. The release of gas must not cause extreme annoyance or discomfort to crew members so as to prevent the correct performance of assigned duties. In case of accidental activation, all hazardous effects must be confined within the equipment and must not produce extreme noise.</p> <p>e) Security type equipment that is defective or that has been damaged is forbidden for transport.</p> <p>The words “not restricted” and the special provision number A178 must be provided on the air waybill when an air waybill is issued.</p>
A179	For UN 3077, irrespective of the maximum net quantities specified in columns 11 and 13 of Table 3-1, intermediate bulk containers (IBCs) with a maximum net quantity not exceeding 1 000 kg are permitted in accordance with Packing Instruction 956.
A180	<p>Non-infectious specimens, such as specimens of mammals, birds, amphibians, reptiles, fish, insects and other invertebrates containing small quantities of UN 1170, UN 1198, UN 1987 or UN 1219 are not subject to these Instructions provided the following packing and marking requirements are met:</p> <ol style="list-style-type: none"> a) specimens are: <ol style="list-style-type: none"> 1) wrapped in paper towel and/or cheesecloth moistened with alcohol or an alcohol solution and then placed in a plastic bag that is heat-sealed. Any free liquid in the bag must not exceed 30 mL; or 2) placed in vials or other rigid containers with no more than 30 mL of alcohol or an alcohol solution; b) the prepared specimens are then placed in a plastic bag that is then heat-sealed; c) the bagged specimens are then placed inside a another plastic bag with absorbent material then heat-sealed; d) the finished bag is then placed in a strong outer packaging with suitable cushioning material; e) the total quantity of flammable liquid per outer packaging must not exceed 1 L; and f) the completed package is marked “scientific research specimens, not restricted Special Provision A180 applies”. <p>The words “not restricted” and the special provision number A180 must be provided on the air waybill when an air waybill is issued.</p>
A181	When a package contains a combination of lithium batteries contained in equipment and lithium batteries packed with equipment, the package must be marked UN 3091 Lithium metal batteries packed with equipment , or UN 3481 Lithium ion batteries packed with equipment , as appropriate. If a package contains both lithium metal batteries and lithium ion batteries, the package must be marked as required for both battery types. However, button cell batteries installed in equipment (including circuit boards) need not be considered.
A182	Equipment containing only lithium batteries must be classified as either UN 3091 or UN 3481.
A183	Waste batteries and batteries being shipped for recycling or disposal are forbidden from air transport unless approved by the appropriate national authority of the State of Origin and the State of the Operator.
A184	(304) This entry may only be used for the transport of non-activated batteries which contain dry potassium hydroxide and which are intended to be activated prior to use by the addition of an appropriate amount of water to the individual cells.

TIs UN

A185 (360) Vehicles only powered by lithium metal batteries or lithium ion batteries must be consigned under the entry UN 3171 **Battery-powered vehicle**.

A186 (361) This entry applies to electric double layer capacitors with an energy storage capacity greater than 0.3 Wh. Capacitors with an energy storage capacity of 0.3 Wh or less are not subject to these Instructions. Energy storage capacity means the energy held by a capacitor, as calculated using the nominal voltage and capacitance. All capacitors to which this entry applies, including capacitors containing an electrolyte that does not meet the classification criteria of any class or division of dangerous goods, must meet the following conditions:

- a) capacitors not installed in equipment must be transported in an uncharged state. Capacitors installed in equipment must be transported either in an uncharged state or protected against a short circuit;
- b) each capacitor must be protected against a potential short circuit hazard in transport as follows:
 - i) when a capacitor's energy storage capacity is less than or equal to 10 Wh or when the energy storage capacity of each capacitor in a module is less than or equal to 10 Wh, the capacitor or module must be protected against a short circuit or be fitted with a metal strap connecting the terminals; and
 - ii) when the energy storage capacity of a capacitor or a capacitor in a module is more than 10 Wh, the capacitor or module must be fitted with a metal strap connecting the terminals;
- c) capacitors containing dangerous goods must be designed to withstand a 95 kPa pressure differential;
- d) capacitors must be designed and constructed to safely relieve pressure that may build up in use, through a vent or a weak point in the capacitor casing. Any liquid which is released upon venting must be contained by the packaging or by the equipment in which a capacitor is installed; and
- e) capacitors manufactured after 31 December 2013 must be marked with the energy storage capacity in Wh.

≠

Capacitors containing an electrolyte not meeting the classification criteria of any class or division of dangerous goods, including when installed in equipment, are not subject to other provisions of these Instructions.

Capacitors containing an electrolyte meeting the classification criteria of any class or division of dangerous goods, with an energy storage capacity of 10 Wh or less are not subject to other provisions of these Instructions when they are capable of withstanding a 1.2 metre drop test unpackaged on an unyielding surface without loss of contents.

Capacitors containing an electrolyte meeting the classification criteria of any class or division of dangerous goods that are not installed in equipment and with an energy storage capacity of more than 10 Wh are subject to these Instructions.

Capacitors installed in equipment and containing an electrolyte meeting the classification criteria of any class or division of dangerous goods are not subject to other provisions of these Instructions provided the equipment is packaged in a strong outer packaging constructed of suitable material and of adequate strength and design in relation to the packaging's intended use and in such a manner as to prevent accidental functioning of capacitors during transport. Large robust equipment containing capacitors may be offered for transport unpackaged or on pallets when capacitors are afforded equivalent protection by the equipment in which they are contained.

Note.— Capacitors which by design maintain a terminal voltage (e.g. asymmetrical capacitors) do not belong to this entry.

A187 (362) This entry applies to liquids, pastes or powders, pressurized with a propellant which meets the definition of a gas in 2;2.1.1 and 2;2.1.2 a) or b).

Note.— A chemical under pressure in an aerosol dispenser must be transported under UN 1950.

The following provisions must apply:

- a) The chemical under pressure must be classified based on the hazard characteristics of the components in the different states:

<i>TIs</i>	<i>UN</i>
	<ul style="list-style-type: none"> i) the propellant; ii) the liquid; or iii) the solid. <p>If one of these components, which can be a pure substance or a mixture, needs to be classified as flammable, the chemical under pressure must be classified as flammable in Division 2.1. Flammable components are flammable liquids and liquid mixtures, flammable solids and solid mixtures or flammable gases and gas mixtures meeting the following criteria:</p> <ul style="list-style-type: none"> i) a flammable liquid is a liquid having a flashpoint of not more than 93°C; ii) a flammable solid is a solid which meets the criteria in 2;4.2.2 of these Instructions; iii) a flammable gas is a gas which meets the criteria in 2;2.2.1 of these Instructions;
	<ul style="list-style-type: none"> b) gases of Division 2.3 and gases with a subsidiary risk of 5.1 must not be used as a propellant in a chemical under pressure; c) where the liquid or solid components are classified as dangerous goods of Division 6.1, Packing Groups II or III, or Class 8, Packing Groups II or III, the chemical under pressure must be assigned a subsidiary risk of Division 6.1 or Class 8 and the appropriate UN number must be assigned. Components classified in Division 6.1, Packing Group I, or Class 8, Packing Group I, must not be used for transport under this proper shipping name; d) in addition, chemicals under pressure with components meeting the properties of: Class 1, explosives; Class 3, liquid desensitized explosives; Division 4.1, self-reactive substances and solid desensitized explosives; Division 4.2, substances liable to spontaneous combustion; Division 4.3, substances which, in contact with water, emit flammable gases; Division 5.1, oxidizing substances; Division 5.2, organic peroxides; Division 6.2, infectious substances; or Class 7, radioactive material, must not be used for transport under this proper shipping name;
+	<ul style="list-style-type: none"> e) Chemicals under pressure containing components forbidden for transport on both passenger and cargo aircraft (columns 10 to 13 of Table 3-1) must not be transported by air.
A188	(359) Nitroglycerin solution in alcohol with more than 1 per cent but not more than 5 per cent nitroglycerin must be classified in Class 1 and assigned to UN 0144 if not all the requirements of Packing Instruction 371 are complied with.
≠	<p>A189 Except where the defining criteria of another class or division are met, concentrations of formaldehyde solution:</p> <ul style="list-style-type: none"> — with less than 25 per cent but not less than 10 per cent formaldehyde must be classified as UN 3334 Aviation regulated liquid, n.o.s.; and — with less than 10 per cent formaldehyde are not subject to these Instructions.
≠	<p>A190 (373) Neutron radiation detectors containing non-pressurized boron trifluoride gas in excess of 1 g and radiation detection systems containing neutron radiation detectors as components may be transported on cargo aircraft in accordance with all applicable requirements of these Instructions irrespective of the indication of “forbidden” in columns 12 and 13 of Table 3-1 and with “Toxic gas” and “Corrosive” labels displayed on each package irrespective of no labels being indicated in column 5, provided the following conditions are met:</p> <ul style="list-style-type: none"> a) each radiation detector must meet the following conditions: <ul style="list-style-type: none"> i) the pressure in each neutron radiation detector must not exceed 105 kPa absolute at 20°C; ii) the amount of gas must not exceed 13 grams per detector; iii) each detector must be manufactured under a registered quality assurance programme; <p style="margin-left: 40px;"><i>Note.— The application of ISO 9001:2008 may be considered acceptable for this purpose.</i></p> iv) each neutron radiation detector must be of welded metal construction with brazed metal to ceramic feed through assemblies. These detectors must have a minimum burst pressure of 1 800 kPa as demonstrated by design type qualification testing; and

TIs UN

- v) each detector must be tested to a 1×10^{-10} cm³/s leaktightness standard before filling.
- b) radiation detectors transported as individual components must be transported as follows:
- i) they must be packed in a sealed intermediate plastic liner with sufficient absorbent material to absorb the entire gas contents;
 - ii) they must be packed in strong outer packagings and the completed package must be capable of withstanding a 1.8 m drop test without leakage of gas contents from detectors; and
 - iii) the total amount of gas from all detectors per outer packaging must not exceed 52 grams.
- c) completed neutron radiation detector systems containing detectors meeting the conditions of sub-paragraph a) must be transported as follows:
- i) the detectors must be contained in a strong sealed outer casing;
 - ii) the casing must contain sufficient absorbent material to absorb the entire gas contents; and
 - iii) the completed system must be packed in strong outer packagings capable of withstanding a 1.8 m drop test without leakage unless a system's outer casing affords equivalent protection.

Transport in accordance with this special provision must be noted on the dangerous goods transport document. A packing instruction must not be shown on the transport document.

When transported as cargo, neutron radiation detectors containing not more than 1 gram of boron trifluoride, including those with solder glass joints, are not subject to these Instructions provided they meet the requirements in sub-paragraph a) and are packed in accordance with sub-paragraph b) irrespective of the indication of "forbidden" in columns 10 to 13. Radiation detection systems containing such detectors are not subject to these Instructions provided they are packed in accordance with sub-paragraph c). The words "not restricted" and the special provision number A190 must be provided on the air waybill when an air waybill is used.

- A191 Notwithstanding the Division 6.1 subsidiary risk shown in column 4 of Table 3-1, the toxic subsidiary risk label and an indication of this subsidiary risk on the dangerous goods transport document are not required when the manufactured articles contain not more than 5 kg of mercury. Transport in accordance with this special provision must be noted on the dangerous goods transport document.
- + A192 (367) For the purposes of documentation and package marking:
- the proper shipping name **Paint related material** may be used for consignments of packages containing paint and paint related material in the same package;
 - the proper shipping name **Paint related material, corrosive, flammable** may be used for consignments of packages containing paint, corrosive, flammable and paint related material, corrosive, flammable in the same package;
 - the proper shipping name **Paint related material, flammable, corrosive** may be used for consignments of packages containing paint, flammable, corrosive and paint related material, flammable, corrosive in the same package; and
 - the proper shipping name **Printing ink related material** may be used for consignments of packages containing printing ink and printing ink related material in the same package.
- + A193 (368) In the case of non-fissile or fissile-excepted uranium hexafluoride, the material must be classified under UN 3507 or UN 2978.
- + A194 (369) In accordance with Part 2, Introductory Chapter, paragraph 4, this radioactive material in an excepted package possessing corrosive properties is classified in Class 8 with a radioactive material subsidiary risk.
- Uranium hexafluoride may be classified under this entry only if the conditions of 2;7.2.4.1.1.2, 2;7.2.4.1.1.5, 2;7.2.4.5.2 and, for fissile-excepted material, of 2;7.2.3.6 are met.
- In addition to the provisions applicable to the transport of Class 8 substances, the provisions of 5;1.2.2.2, 5;1.6.3, 7;1.6 and 7;3.2.1 to 7;3.2.4 apply.
- No Class 7 label is required to be displayed.

TIs UN

- + A195 (371) 1) This entry also applies to articles containing a small pressure receptacle with a release device. Such articles must comply with the following requirements:
- a) the water capacity of the pressure receptacle must not exceed 0.5 litres and the working pressure must not exceed 25 bar at 15°C;
 - b) the minimum burst pressure of the pressure receptacle must be at least four times the pressure of the gas at 15°C;
 - c) each article must be manufactured in such a way that unintentional firing or release is avoided under normal conditions of handling, packing, transport and use. This may be achieved by an additional locking device linked to the activator;
 - d) each article must be manufactured in such a way as to prevent hazardous projections of the pressure receptacle or parts of the pressure receptacle;
 - e) each pressure receptacle must be manufactured from material which will not fragment upon rupture;
 - f) the design type of the article must be subjected to a fire test. For this test, the provisions of paragraphs 16.6.1.2, except sub-paragraph g), 16.6.1.3.1 to 16.6.1.3.6, 16.6.1.3.7 b) and 16.6.1.3.8 of the UN *Manual of Tests and Criteria* must be applied. It must be demonstrated that the article relieves its pressure by means of a fire degradable seal or other pressure relief device, in such a way that the pressure receptacle will not fragment and that the article or fragments of the article do not rocket more than 10 metres; and
 - g) the design type of the article must be subjected to the following test. A stimulating mechanism must be used to initiate one article in the middle of the packaging. There must be no hazardous effects outside the package such as disruption of the package, metal fragments or a receptacle which passes through the packaging.
- 2) The manufacturer must produce technical documentation of the design type, manufacture as well as the tests and their results. The manufacturer must apply procedures to ensure that articles produced in a series are made of good quality, conform to the design type and are able to meet the requirements in 1). The manufacturer must provide such information to the appropriate national authority on request.

- + A196 (372) This entry applies to asymmetric capacitors with an energy storage capacity greater than 0.3 Wh. Capacitors with an energy storage capacity of 0.3 Wh or less are not subject to these Instructions.

Energy storage capacity means the energy stored in a capacitor, as calculated according to the following equation:

$$Wh = 1/2C_N(U_R^2 - U_L^2) \times (1/3600),$$

using the nominal capacitance (C_N), rated voltage (U_R) and rated lower limit voltage (U_L).

All asymmetric capacitors to which this entry applies must meet the following conditions:

- a) capacitors or modules must be protected against short circuit;
- b) capacitors must be designed and constructed to safely relieve pressure that may build up in use, through a vent or a weak point in the capacitor casing. Any liquid which is released upon venting must be contained by packaging or by equipment in which a capacitor is installed;
- c) capacitors manufactured after 31 December 2015 must be marked with the energy storage capacity in Wh; and
- d) capacitors containing an electrolyte meeting the classification criteria of any class or division of dangerous goods must be designed to withstand a 95 kPa pressure differential.

Capacitors containing an electrolyte not meeting the classification criteria of any class or division of dangerous goods, including when configured in a module or when installed in equipment, are not subject to other provisions of these Instructions.

TIs UN

Capacitors containing an electrolyte meeting the classification criteria of any class or division of dangerous goods, with an energy storage capacity of 20 Wh or less, including when configured in a module, are not subject to other provisions of these Instructions when the capacitors are capable of withstanding a 1.2 m drop test unpackaged on an unyielding surface without loss of contents.

Capacitors containing an electrolyte meeting the classification criteria of any class or division of dangerous goods that are not installed in equipment and with an energy storage capacity of more than 20 Wh are subject to these Instructions.

Capacitors installed in equipment and containing an electrolyte meeting the classification criteria of any class or division of dangerous goods are not subject to other provisions of these Instructions provided that the equipment is packaged in a strong outer packaging constructed of suitable material, and of adequate strength and design, in relation to the packaging's intended use and in such a manner as to prevent accidental functioning of capacitors during transport. Large robust equipment containing capacitors may be offered for transport unpackaged or on pallets when capacitors are afforded equivalent protection by the equipment in which they are contained.

*Note.— Notwithstanding the provisions of this special provision, nickel-carbon asymmetric capacitors containing Class 8 alkaline electrolytes must be transported as UN 2795, **Batteries, wet, filled with alkali, electric storage.***

- + A197 (375) These substances when transported in single or combination packagings containing a net quantity per single or inner packaging of 5 L or less for liquids or having a net mass per single or inner packaging of 5 kg or less for solids, are not subject to any other provisions of these Instructions provided the packagings meet the general provisions of 4;1.1.1, 4;1.1.3.1 and 4;1.1.5.
- + A198 Hay, straw and bhusa, when not wet, damp or contaminated with oil are not subject to these Instructions.
- + A199 Nickel-metal hydride batteries or nickel-metal hydride battery-powered devices, equipment or vehicles having the potential of a dangerous evolution of heat are not subject to these Instructions provided they are prepared for transport so as to prevent:
 - a) a short circuit (e.g. in the case of batteries, by the effective insulation of exposed terminals, or, in the case of equipment, by disconnection of the battery and protection of exposed terminals); and
 - b) unintentional activation.

The words "not restricted" and the special provision number A199 must be provided on the air waybill when an air waybill is issued.

- + A200 This entry applies to packagings that contain residues of dangerous goods and which no longer meet the provisions of Part 6. These packagings are forbidden for transport by air. Such packagings or parts thereof must be transported in accordance with Part 4;1.1.15 of these Instructions.
- + A201 A consignment of lithium metal batteries may be transported on passenger aircraft only with the prior approval of the appropriate authority of the State of Origin and the State of the Operator under the written conditions established by those authorities. The conditions must include the quantity limitations, size limitations and packing requirements established in the Supplement (see S-3;4, Table S-3 1). Copies of the documents of approval, showing the quantity limitations and packing requirements, must accompany the consignment. Authorities issuing approvals in accordance with this special provision must provide a copy to the Chief of the Cargo Safety Section within three months via email at CSS@icao.int, via facsimile at +1 514-954-6077 or via post to the following address:

Chief, Cargo Safety Section
International Civil Aviation Organization
999 University Street
Montreal, Quebec
CANADA H3C 5H7

When States, other than the State of Origin and the State of the Operator, have notified ICAO that they require prior approval of shipments made under this special provision, approval must also be obtained from these States, as appropriate.

Chapter 4

DANGEROUS GOODS IN LIMITED QUANTITIES

Note.— The UN Recommendations contain provisions for limited quantities of dangerous goods. These recognize that many dangerous goods when in reasonably limited quantities present a reduced hazard during transport and can safely be carried in good quality packagings of the types specified in the Recommendations but which have not been tested and marked accordingly. The provisions contained in this paragraph are based on those in the UN Recommendations and allow limited quantities of dangerous goods to be transported in packagings which, although not tested and marked in accordance with Part 6 of these Instructions, do meet the construction requirements of that part. The UN Recommendations require packages containing limited quantities of dangerous goods to be marked with a diamond shaped mark as specified in Chapter 3.4 of the UN Model Regulations. The mark required by these Instructions includes all of the elements of this mark with the addition of a “Y” which indicates compliance with the provisions of these Instructions, some of which are more stringent than those of the UN Model Regulations and of other modes of transport. For example, packages transported in accordance with these Instructions require hazard labels, and inner packaging and per-package quantities are in some cases lower than those authorized by the UN Model Regulations. The UN Model Regulations recognize the mark required by these Instructions in order to ensure that packages containing limited quantities of dangerous goods prepared in accordance with these Instructions are acceptable for transport by other modes.

4.1 APPLICABILITY

4.1.1 Limited quantities of dangerous goods may only be carried in accordance with the limitations and provisions of this chapter and must meet all the applicable requirements of the Technical Instructions unless otherwise provided for below.

4.1.2 Only dangerous goods which are permitted on passenger aircraft and which meet the criteria of the following classes, divisions and packing groups (if appropriate) may be carried under these provisions for dangerous goods in limited quantities:

	Class 2	Only UN 1950 in Divisions 2.1 and 2.2, UN 2037 in Divisions 2.1 and 2.2 without a subsidiary risk, UN 3478 (Fuel cell cartridges , containing liquefied flammable gas) and UN 3479 (Fuel cell cartridges , containing hydrogen in metal hydride)
≠	Class 3	Packing Groups II and III and UN 3473 (Fuel cell cartridges , containing flammable liquids)
	Division 4.1	Packing Groups II and III but excluding all self-reactive substances irrespective of packing group
≠	Division 4.3	Packing Groups II and III, solids only and UN 3476 (Fuel cell cartridges , containing water-reactive substances)
	Division 5.1	Packing Groups II and III
	Division 5.2	Only when contained in a chemical kit or a first-aid kit
	Division 6.1	Packing Groups II and III
≠	Class 8	Packing Groups II and III and UN 3477 (Fuel cell cartridges , containing corrosive substances) but excluding UN 2794, UN 2795, UN 2803, UN 2809, UN 3028 and UN 3506
≠	Class 9	Only UN 1941, UN 1990, UN 2071, UN 3077, UN 3082, UN 3316, UN 3334, UN 3335 and ID 8000

Note.— Many articles or substances, including the following, are NOT permitted under these limited quantity provisions:

- a) *those permitted only on cargo aircraft;*
- b) *those in Packing Group I;*
- ≠ c) *those in Class 1 or 7 or Divisions 2.1 (except as permitted above), 2.3 or 6.2;*
- d) *those in Division 4.2 or with a subsidiary risk 4.2.*

4.1.3 The limitations and provisions of this chapter for the transport of dangerous goods in limited quantities apply equally to both passenger and cargo aircraft.

4.2 PACKING AND PACKAGINGS

4.2.1 The general packing requirements of 4;1.1 applicable to passenger aircraft must be met except that the requirements of 4;1.1.2, 4;1.1.9 c), 4;1.1.9 e), 4;1.1.16, 4;1.1.18 and 4;1.1.20 do not apply.

4.2.2 Packagings, including closures, which have been used more than once (i.e. they have been refilled and are being reshipped after having previously been emptied) must be inspected thoroughly and must be in such condition that they will protect their contents and perform their containment functions as efficiently as new packagings. Cushioning and absorbent materials if used previously must remain capable of performing their primary functions.

4.2.3 Single packagings, including composite packagings, are not permitted.

4.2.4 Limited quantities of dangerous goods must be packed in accordance with the applicable limited quantity packing instruction identified by the prefix letter "Y" indicated in column 10 of Table 3-1.

4.2.5 Inner packagings must meet the requirements of 6;3.2. Outer packagings must be so designed that they meet the construction requirements in 6;3.1 which apply to the type of outer packaging to be used for the article or substance.

4.3 QUANTITY LIMITATIONS

4.3.1 The net quantity per package must not exceed the quantity specified in column 11 of Table 3-1 against the packing instruction number identified by the prefix letter "Y" in column 10.

4.3.2 The gross mass per package must not exceed 30 kg.

4.3.3 When different dangerous goods are contained in one outer packaging, the quantities of such dangerous goods must be so limited that:

- a) for classes other than Classes 2 (except UN 2037, UN 3478 and UN 3479) and 9, the total net quantity in the package does not exceed the value of 1, where "Q" is calculated using the formula:

$$Q = \frac{n_1}{M_1} + \frac{n_2}{M_2} + \frac{n_3}{M_3} + \dots$$

where n_1 , n_2 , etc., are the net quantities of the different dangerous goods and M_1 , M_2 etc., are the maximum net quantities for these different dangerous goods shown in Table 3-1 against the relevant "Y" packing instructions; and

- b) for Classes 2 (except UN 2037, UN 3478 and UN 3479) and 9:

- 1) when packed together without goods of other classes, the gross mass of the package does not exceed 30 kg; or
- 2) when packed together with goods of other classes, the gross mass of the package does not exceed 30 kg and the total net quantity in the package of goods other than in Classes 2 (except UN 2037, UN 3478 and UN 3479) or 9 does not exceed the value of 1 when calculated according to a) above.

- c) carbon dioxide, solid (dry ice), UN 1845 may be packed together with goods of other classes, provided that the gross mass of the package does not exceed 30 kg. The quantity of dry ice does not need to be taken into account in the calculation of the "Q" value. However, the packaging containing the carbon dioxide, solid (dry ice) and the outer packaging must permit the release of carbon dioxide gas.

4.3.4 Where the different dangerous goods in the outer packaging consist only of those with the same UN number, packing group and physical state (i.e. solid or liquid), the calculation in 4.3.3 a) does not need to be made. However, the total net quantity in the package must not exceed the maximum net quantity according to Table 3-1.

4.4 PACKAGE TESTING

4.4.1 Each package offered for transport must be capable of withstanding a 1.2 m drop test on to a rigid, non-resilient, flat and horizontal surface, in the position most likely to cause damage. The criteria for passing the test is that the outer packaging must not exhibit any damage liable to affect safety during transport and there must be no leakage from the inner packaging(s).

4.4.2 Each package offered for transport must be capable of withstanding, without breakage or leakage of any inner packaging and without significant reduction of effectiveness, a force applied to the top surface for a duration of 24 hours equivalent to the total weight of identical packages if stacked to a height of 3 m (including the test sample).

4.5 PACKAGE MARKING

4.5.1 Packages containing limited quantities of dangerous goods must be marked as required by the applicable paragraphs of 5;2, except that 5;2.4.4.1 does not apply.

≠ 4.5.2 Packages containing limited quantities of dangerous goods and prepared in accordance with this chapter must bear the marking shown in Figure 3-1 below. The marking must be readily visible, legible and able to withstand open weather exposure without a substantial reduction in effectiveness. The marking must be in the form of a square set at an angle of 45° (diamond shaped). The top and bottom portions and the surrounding line must be black. The centre area must be white or a suitable contrasting background. The minimum dimension must be 100 mm × 100 mm and the minimum width of the line forming the diamond must be 2 mm. The symbol “Y” must be placed in the centre of the mark and must be clearly visible. Where dimensions are not specified, all features must be in approximate proportion to those shown.

+ 4.5.2.1 If the size of the package so requires, the minimum outer dimensions shown in Figure 3-1 may be reduced to be not less than 50 mm × 50 mm provided the marking remains clearly visible. The minimum width of the line forming the diamond may be reduced to a minimum of 1 mm. The symbol “Y” must remain in approximate proportion to that shown in Figure 3-1.

4.5.3 When packages containing dangerous goods in limited quantities are placed in an overpack, the overpack must be marked with the word “OVERPACK” and the marking required by this chapter, unless the markings representative of all dangerous goods in the overpack are visible.

4.6 PACKAGE LABELLING

4.6.1 Packages containing limited quantities must be labelled as required by the applicable paragraphs of 5;3.

4.7 DANGEROUS GOODS TRANSPORT DOCUMENT

4.7.1 The dangerous goods transport document must comply with all the requirements of 5;4.

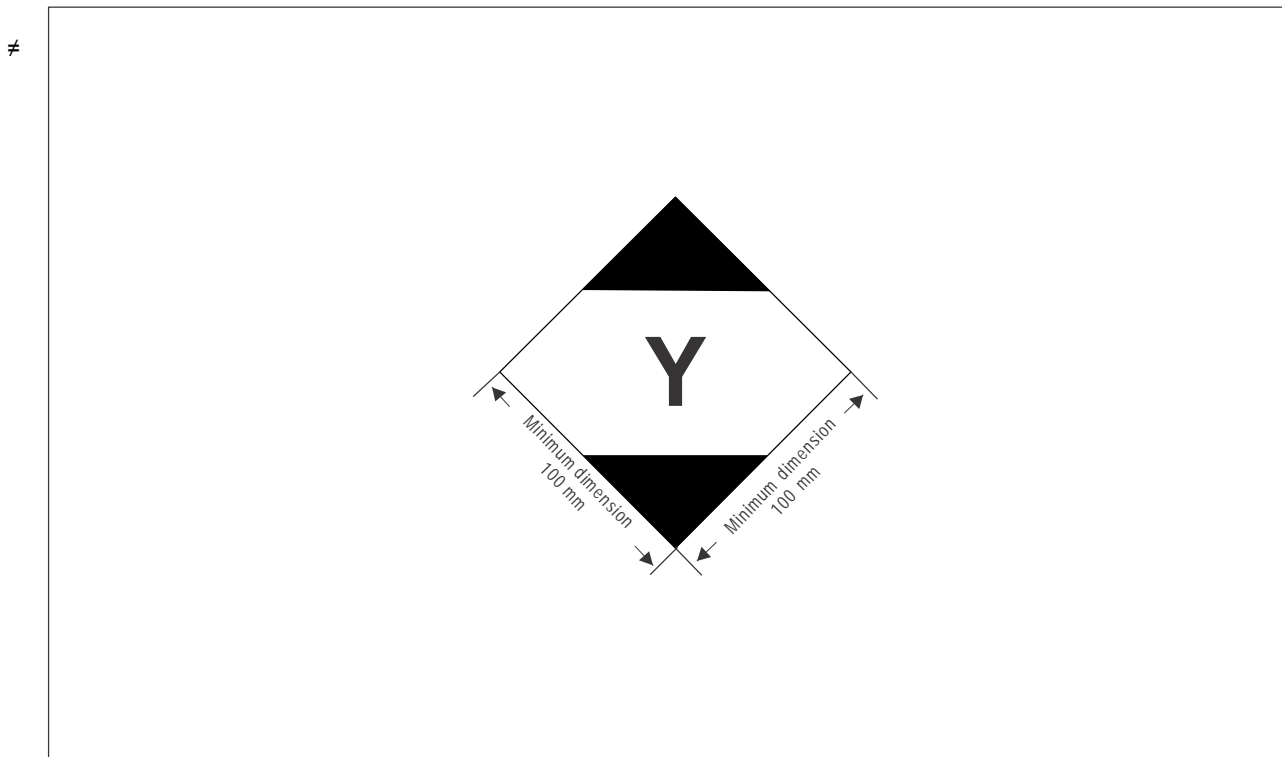

Figure 3-1. Limited quantities mark

Chapter 5

DANGEROUS GOODS PACKED IN EXCEPTED QUANTITIES

Parts of this Chapter are affected by State Variation JP 23; see Table A-1

5.1 EXCEPTED QUANTITIES

5.1.1 Excepted quantities of dangerous goods of certain classes, other than articles, meeting the provisions of this chapter are not subject to any other provisions of these Instructions except for:

- a) the prohibition in post in 1;2.3;
- b) the definitions in 1;3;
- c) the training requirements in 1;4;
- d) the classification procedures and packing group criteria in Part 2;
- ≠ e) the packaging requirements of 4;1.1.1, 4;1.1.3.1, 4;1.1.3.3, 4;1.1.5, 4;1.1.6, 4;1.1.7 and 4;1.1.8 (4;1.1.6 does not apply to UN 3082);
- f) the loading restriction in 7;2.1;
- g) the reporting requirements of dangerous goods accidents, incidents and other occurrences in 7;4.4 and 7;4.5; and
- h) the prohibition of dangerous goods in baggage in 8;1.1.

Note.— In the case of radioactive material, the requirements for radioactive material in excepted packages in 1;6.1.5 apply.

5.1.2 Dangerous goods which may be carried as excepted quantities in accordance with this chapter are shown in column 9 of the dangerous goods list by means of an alphanumeric code as indicated in Table 3-3 below:

Table 3-3. Excepted quantity codes for Table 3-1

<i>Code</i>	<i>Maximum quantity per inner packaging</i>	<i>Maximum quantity per outer packaging</i>
E0	Not permitted as Excepted Quantity	
E1	30 g/30 mL	1 kg/1 L
E2	30 g/30 mL	500 g/500 mL
E3	30 g/30 mL	300 g/300 mL
E4	1 g/1 mL	500 g/500 mL
E5	1 g/1 mL	300 g/300 mL

5.1.2.1 For gases, the volume indicated for inner packagings refers to the water capacity of the inner receptacle and the volume indicated for outer packagings refers to the combined water capacity of all inner packagings within a single outer package.

5.1.3 Where dangerous goods in excepted quantities for which different codes are assigned are packaged together, the total quantity per outer packaging must be limited to that corresponding to the most restrictive Code.

5.2 PACKAGINGS

5.2.1 Packagings used for the transport of dangerous goods in excepted quantities must be in compliance with the following:

- a) there must be an inner packaging and each inner packaging must be constructed of plastic (when used for liquid dangerous goods it must have a thickness of not less than 0.2 mm), or of glass, porcelain, stoneware, earthenware or metal (see also 4;1.1.3.1) and the closure of each inner packaging must be held securely in place with wire, tape or other positive means; any receptacle having a neck with moulded screw threads must have a leak proof threaded type cap. The closure must be resistant to the contents;
- b) each inner packaging must be securely packed in an intermediate packaging with cushioning material in such a way that, under normal conditions of transport, they cannot break, be punctured or leak their contents. The intermediate packaging must completely contain the contents in case of breakage or leakage, regardless of package orientation. For liquid dangerous goods, the intermediate packaging must contain sufficient absorbent material to absorb the entire contents of the inner packaging. In such cases, the absorbent material may be the cushioning material. Dangerous goods must not react dangerously with cushioning, absorbent material and packaging material or reduce the integrity or function of the materials;
- c) the intermediate packaging must be securely packed in a strong, rigid outer packaging (wooden, fibreboard or other equally strong material);
- d) each package type must be in compliance with the provisions in 5.3;
- e) each package must be of such a size that there is adequate space to apply all necessary markings; and
- f) overpacks may be used and may also contain packages of dangerous goods or goods not subject to these Instructions provided that the packages are secured within the overpack.

5.3 TESTS FOR PACKAGES

5.3.1 The complete package as prepared for transport, with inner packagings filled to not less than 95 per cent of their capacity for solids or 98 per cent for liquids, must be capable of withstanding, as demonstrated by testing which is appropriately documented, without breakage or leakage of any inner packaging and without significant reduction in effectiveness:

- a) drops onto a rigid, non-resilient flat and horizontal surface from a height of 1.8 m:
 - 1) where the sample is in the shape of a box, it must be dropped in each of the following orientations:
 - flat on the base;
 - flat on the top;
 - flat on the longest side;
 - flat on the shortest side;
 - on a corner;
 - 2) where the sample is in the shape of a drum, it must be dropped in each of the following orientations:
 - diagonally on the top chime, with the centre of gravity directly above the point of impact;
 - diagonally on the base chime;
 - flat on the side.

Note.— Each of the above drops may be performed on different but identical packages.

- b) a force applied to the top surface for a duration of 24 hours, equivalent to the total weight of identical packages if stacked to a height of 3 m (including the drop sample).

5.3.2 For the purposes of testing, the substances to be transported in the packaging may be replaced by other substances except where this would invalidate the results of the tests. For solids, when another substance is used, it must have the same physical characteristics (mass, grain size, etc.) as the substance to be carried. In the drop tests for liquids, when another substance is used, its relative density (specific gravity) and viscosity must be similar to those of the substance to be transported.

5.4 MARKING OF PACKAGES

5.4.1 Packages containing excepted quantities of dangerous goods prepared in accordance with this chapter must be durably and legibly marked with the mark shown in Figure 3-2. The primary hazard class or, when assigned, the division of each of the dangerous goods contained in the package must be shown in the mark. Where the name of the shipper or consignee is not shown elsewhere on the package, this information must be included within the mark.

≠ 5.4.2 The marking must be in the form of a square. The hatching and symbol must be of the same colour, black or red, on white or suitable contrasting background. The dimensions of the mark must be a minimum of 100 mm × 100 mm. Where dimensions are not specified, all features must be in approximate proportion to those shown.

5.4.3 An overpack containing dangerous goods in excepted quantities must display the markings required by 5.4.1, unless such markings on packages within the overpack are clearly visible.

5.5 DOCUMENTATION

If a document such as an air waybill accompanies dangerous goods in excepted quantities, it must include the statement "Dangerous Goods in Excepted Quantities" and indicate the number of packages.

5.6 DE MINIMIS QUANTITIES

Dangerous goods assigned to codes E1, E2, E4 or E5 are not subject to these Instructions when carried as cargo provided that:

- the maximum net quantity of material per inner packaging is limited to 1 mL for liquids and gases and 1 g for solids;
- the provisions of 5.2 are met, except that an intermediate packaging is not required if the inner packagings are securely packed in an outer packaging with cushioning material in such a way that, under normal conditions of transport, they cannot break, be punctured, or leak their contents; and for liquid dangerous goods, the outer packaging contains sufficient absorbent material to absorb the entire contents of the inner packagings;
- the provisions of 5.3 are complied with; and
- the maximum net quantity of dangerous goods per outer packaging does not exceed 100 g for solids or 100 mL for liquids and gases.

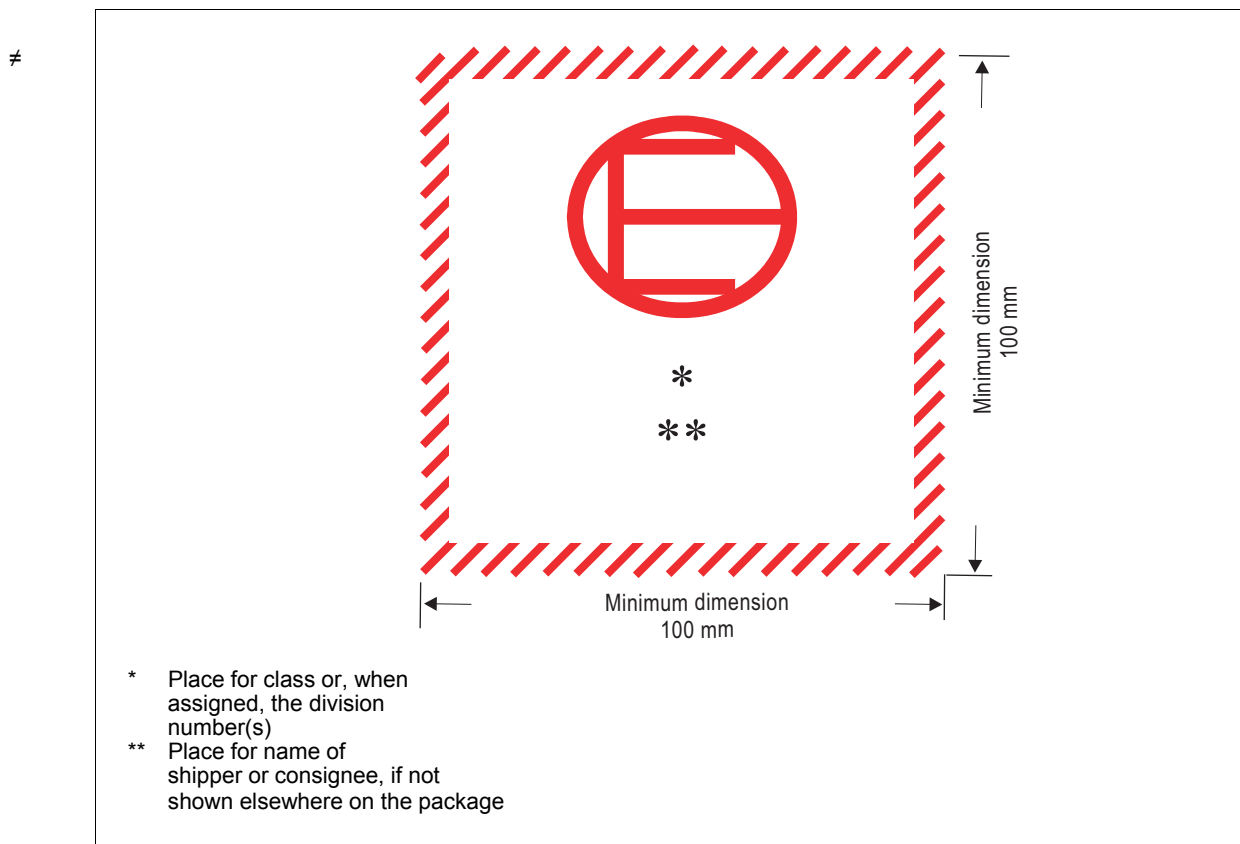

Figure 3-2. Excepted quantities mark

Part 4

PACKING INSTRUCTIONS

INTRODUCTORY NOTES

Note 1.— Packing groups

For packing purposes, dangerous goods other than those of Classes 1, 2 and 7, Divisions 5.2 and 6.2 and self-reactive substances of Division 4.1 are assigned to three packing groups in accordance with the degree of danger they present:

- Packing Group I — Substances presenting high danger
- Packing Group II — Substances presenting medium danger
- Packing Group III — Substances presenting low danger

Some substances in Class 9 and liquids in Division 5.1 have been assigned to packing groups by experience rather than through application of technical criteria. The packing group to which a substance is assigned is listed in Table 3-1. The criteria for the packing groups are given in Part 2, Chapters 3, 4, 5, 6 and 8.

Note 2.— Temperature variations

For the information of users of these Instructions, the extremes of temperature which may be encountered in international transportation are in the order of -40°C and 55°C . Since receptacles or packagings may be filled at low temperatures and then exposed in transit in tropical areas, the increase in temperature may tend to cause discharge of liquid contents or bursting of the receptacles or packagings during transit, unless a suitable ullage (outage) has been provided and the receptacles or packagings meet the pressure requirement specified in 1.1.6 of this Part.

Note 3.— Pressure variations

Due to altitude, the ambient pressure experienced by a package in flight will be lower than standard atmospheric pressure at sea level. Since receptacles or packagings will generally be filled at a standard atmospheric pressure of approximately 100 kPa, this lower ambient pressure will result in a pressure differential between the contents of the receptacle or package and the cargo compartment. For pressurized cargo compartments, the pressure differential may be approximately 25 kPa, while for non-pressurized or partially pressurized cargo compartments, the pressure differential may be as much as 75 kPa. This pressure differential will tend to cause discharge of liquid contents or bursting of the receptacles or packagings during flight unless each receptacle or packaging and its closures meet the packaging test requirements.

Note 4.— Vibrations

Vibrations in commercial aircraft to which packagings may be exposed range from 5 mm amplitude at 7 Hz (corresponding to 1 g acceleration), to 0.05 mm amplitude at 200 Hz (corresponding to 8 g acceleration).

Note 5.— Nomenclature

A nomenclature of some packaging terms used in the Instructions is given in 1;3.1. Explanations of the codes used in this Part to designate types of inner and outer packagings may be found in Tables 6-2 and 6-3.

Note 6.— Portable tanks

With the approval of the appropriate authority of the State of Origin and the State of the Operator, certain dangerous goods may also be carried on cargo aircraft in portable tanks in accordance with the provisions of Part S-4, Chapter 12 of the Supplement.

≠ Note 7.— Carriage of oxygen and air with aquatic animals

With the approval of the appropriate authority of the State of Origin, of Destination and of the Operator, for the purpose of providing life support to aquatic animals during transport, cylinders containing Oxygen compressed (UN 1072) or Air, compressed (UN 1002) may be carried to oxygenate the water in accordance with the provisions of Table S-3-1 and Special Provision A302 (which appear in the Supplement).

Note 8.— Packagings for explosives, self-reactive substances and organic peroxides

Unless specific provision to the contrary is made in these Instructions, the packagings used for goods of Class 1, self-reactive substances of Division 4.1 and organic peroxides of Division 5.2 should comply with the provisions for the medium danger (Packing Group II) category.

Note 9.— Additional requirements for the air mode

The transport of dangerous goods by air is subject to requirements additional to those of other modes of transport (e.g. quantity limitations, requirements for absorbent material, pressure differential requirements, appropriate closure procedures, specific packing instruction requirements).

≠ *Note 10.— Carriage of flames*

With the approval of the appropriate authority of the State of Origin, or transit (where applicable), of Destination and of the Operator, lamps fuelled by UN 1223 — **Kerosene** or UN 3295 — **Hydrocarbons, liquid, n.o.s.**, carried by a passenger to transport a symbolic flame (e.g. Olympic flame, Peace flame) may be carried in accordance with the provisions of Special Provision A324 (which appears in the Supplement to this document).

Note 11.— Open external carriage

When dangerous goods are prepared for open external carriage (e.g. suspended from a helicopter or in open external carrying devices), consideration should be given to the type of packaging used and protection of those packagings where necessary from the effects of airflow and weather (e.g. by damage from rain or snow).

Chapter 1

GENERAL PACKING REQUIREMENTS

*Parts of this Chapter are affected by State Variations JP 24;
see Table A-1*

1.1 GENERAL REQUIREMENTS APPLICABLE TO ALL CLASSES EXCEPT CLASS 7

1.1.1 Dangerous goods must be packed in good quality packagings, which must be strong enough to withstand the shocks and loadings normally encountered during transport, including removal from a pallet, unit load device or overpack for subsequent manual or mechanical handling. Packagings must be constructed and closed so as to prevent any loss of contents when prepared for transport, which may be caused under normal conditions of transport, by vibration, or by changes in temperature, humidity or pressure (resulting from altitude, for example). Packagings (including inner packagings and receptacles) must be closed in accordance with the information provided by the manufacturer. No dangerous residue must adhere to the outside of packages during transport. These provisions apply, as appropriate, to new, reused, reconditioned or re-manufactured packagings.

Note.— The nature of transport dictates that many packages are likely to be moved between different modes of transport with the attendant increase in handling, e.g. from vehicles into warehouses and then onto aircraft. Additionally, packages consigned on a pallet may be removed from that pallet to assist handling and loading which may be carried out manually. To avoid damage and leakage from packages during transport, shippers should take this into account in selecting an appropriate packaging or in making the decision about the suitability of an already packaged item. In this respect, it is recommended that single steel or aluminium packagings (1A1, 1A2, 1B1, 1B2, 3A1, 3A2, 3B1, 3B2), when transported in narrow-bodied aircraft and not otherwise protected by, for example, placement in a unit load device, be provided additional protection against the abrasive effects experienced in loading the aircraft through overpacking, palletization or other means of protecting the bottom head and chime. Also, small single packagings, with a capacity of 2 L or less, should be overpacked to facilitate handling and to permit adequate securing of the dangerous goods aboard the aircraft.

≠ 1.1.2 New, remanufactured, reused or reconditioned packagings which are listed in Tables 6-2 and 6-3, must meet the applicable requirements of Part 6 of these Instructions. Such packagings must be manufactured and tested under a quality assurance programme which satisfies the appropriate national authority, in order to ensure that such packagings meet those applicable requirements. Where packagings are required to be tested in accordance with 6;4, their subsequent use must be as specified in the applicable test report and conform in all respects with the design type which was tested, including the method of packing and size and type of any inner packagings, except as provided for in 1.1.10.1 or 6;4.1.7. Before being filled and handed over for transport, every packaging must be inspected to ensure that it is free from corrosion, contamination or other damage. Any packaging which shows signs of reduced strength as compared with the approved design type must no longer be used or must be so reconditioned that it is able to withstand the design type tests.

Note.— ISO 16106:2006 Packaging — Transport packages for dangerous goods — Dangerous goods packagings, intermediate bulk containers (IBCs) and large packagings — Guidelines for the application of ISO 9001 provides acceptable guidance on procedures which may be followed.

1.1.3 Compatibility requirements

1.1.3.1 Parts of packagings which are in direct contact with dangerous goods:

- a) must not be affected or significantly weakened by those dangerous goods;
- b) must not cause a dangerous effect, e.g. catalyzing a reaction or reacting with the dangerous goods; and
- c) must not allow permeation of the dangerous goods that could constitute a danger under normal conditions of transport.

Where necessary, they must be provided with a suitable inner coating or treatment.

1.1.3.2 Shippers must also ensure that any absorbent materials and the materials of intermediate packagings for liquids do not react dangerously with the liquid.

1.1.3.3 Materials, such as some plastics, which can be significantly softened or rendered brittle or permeable by the temperatures likely to be experienced during transport or because of the chemical action of the contents or the use of a refrigerant, must not be used. Even though certain packagings are specified in individual packing instructions, it is, nevertheless, the responsibility of the shipper to ensure that such packagings are, in every way, compatible with the articles or substances to be contained within such packagings. This particularly applies to corrosivity, permeability, softening, premature aging and embrittlement.

Particular attention should be paid to the following:

- a) the effect of fluorine on glass;
- b) the effects of corrosion on metals such as steel and aluminium; and
- c) consideration of the interaction (such as swelling, permeation, chemical degradation and environmental stress cracking) of substances with polymer materials such as polyethylene and polypropylene.

1.1.3.4 Shippers must ensure that all appropriate measures have been taken to ensure that the packagings used are compatible with the dangerous goods to be transported. Evidence of such measures or assessments must be made available to the competent authority upon request.

1.1.4 The body and the closure of any packaging must be so constructed as to be able to adequately resist the effects of temperature and vibration occurring in normal conditions of transport. The closure device must be so designed that it:

- a) is unlikely that it can be incorrectly or incompletely closed, and must be such that it may be checked easily to determine that it is completely closed; and
- b) remains securely closed during transport.

1.1.4.1 In addition, for inner packagings containing liquids, closures must be held securely, tightly and effectively in place by secondary means. Examples of such methods include: adhesive tape, friction sleeves, welding or soldering, positive locking wires, locking rings, induction heat seals and child-resistant closures. When secondary means of closure cannot be applied, the inner packaging must be securely closed and placed in a leakproof liner and then placed in an outer packaging.

1.1.5 When filling packagings for liquids sufficient ullage (outage) must be left to ensure that neither leakage nor permanent distortion of the packaging will occur as a result of an expansion of the liquid caused by temperatures likely to prevail during transport. Liquids must not completely fill a packaging at a temperature of 55°C.

1.1.6 Packagings for which retention of liquid is a basic function must be capable of withstanding without leakage an internal pressure which produces a pressure differential of not less than 95 kPa (not less than 75 kPa for liquids in Packing Group III of Class 3 or Division 6.1), or a pressure related to the vapour pressure of the liquid to be conveyed, whichever is the greater. The pressure related to the vapour pressure must be determined as either:

- a) the total gauge pressure measured in the packaging (i.e. the vapour pressure of the filling substance and the partial pressure of the air or other inert gases, less 100 kPa) at 55°C, multiplied by a safety factor of 1.5; this total gauge pressure should be determined on the basis of a degree of filling in accordance with 1.1.5 and a filling temperature of 15°C; or
- b) 1.75 times the vapour pressure at 50°C less 100 kPa, but with a minimum of 95 kPa.

This is expressed as:

$$P = (V_{p50} \times 1.75) - 100 \text{ kPa with a minimum of 95 kPa}$$

where

P = Pressure requirement in kPa (gauge)

V_{p50} = Vapour pressure at 50°C; or

- c) 1.5 times the vapour pressure at 55°C less 100 kPa, but with a minimum of 95 kPa.

This is expressed as:

$$P = (V_{p55} \times 1.5) - 100 \text{ kPa with a minimum of 95 kPa}$$

where

P = Pressure requirement in kPa (gauge)

V_{p55} = Vapour pressure at 55°C.

Note.— The capability of a packaging to withstand an internal pressure without leakage that produces the specified pressure differential should be determined by testing samples of inner packagings of combination packagings and single packagings. Pressure differential is the difference between the pressure exerted on the inside of the packaging and the pressure on the outside. The appropriate test method should be selected based on packaging type. Acceptable test methods include any method that produces the required pressure differential between the inside and outside of a single packaging or an inner packaging of a combination packaging. The test may be conducted using internal hydraulic or pneumatic pressure (gauge) or external vacuum test methods. Internal hydraulic or pneumatic pressure can be applied in most cases as the required pressure differential can be achieved under most circumstances. An external vacuum test is not acceptable if the specified

pressure differential is not achieved and maintained. The external vacuum test is a generally acceptable method for rigid packagings but is not normally acceptable for:

- flexible packagings;
- packagings filled and closed under an absolute atmospheric pressure lower than 95 kPa or for liquids in Packing Group III of Class 3 or Division 6.1 with an absolute pressure of 75 kPa;
- packagings intended for the transport of high vapour pressure liquids (i.e. vapour pressure greater than 111 kPa at 50°C or 130 kPa at 55°C and accordingly greater than 100 kPa at 50°C or 117 kPa at 55°C for liquids in Packing Group III of Class 3 or Division 6.1.

1.1.7 Notwithstanding the foregoing, dangerous goods may be contained in an inner packaging which does not itself meet the pressure requirement provided that the inner packaging is packed within a supplementary packaging which does meet the pressure requirement and all the other requirements of this Chapter and the applicable packing instruction.

1.1.8 Dangerous goods must not be packed together in the same outer packaging with dangerous or other goods if they react dangerously with each other and cause:

- a) combustion and/or evolution of considerable heat;
- b) evolution of flammable, toxic or asphyxiant gases;
- c) the formation of corrosive substances; or
- d) the formation of unstable substances.

1.1.9 Subject to 1.1.8 an outer packaging may contain more than one item of dangerous goods provided that:

- a) the inner packaging used for each item of dangerous goods and the quantity contained therein complies with the relevant part of the packing instruction applicable to that item;
- b) the outer packagings used are permitted by all the packing instructions applicable to each item of dangerous goods;
- c) the package as prepared for shipment meets the specification performance tests for the most restrictive packing group of a substance or article contained in the package;
- d) the dangerous goods do not require segregation according to Table 7-1, unless otherwise provided for in these Instructions; and
- e) the quantities of different dangerous goods contained in one outer packaging must be such that "Q" does not exceed the value of 1, where "Q" is calculated using the formula:

$$Q = \frac{n_1}{M_1} + \frac{n_2}{M_2} + \frac{n_3}{M_3} + \dots$$

where n_1 , n_2 , etc. are the net quantities of the different dangerous goods and M_1 , M_2 , etc. are the maximum net quantities for these different dangerous goods according to Table 3-1 for passenger or cargo aircraft as applicable. However, the following dangerous goods do not need to be taken into account in the calculation of the "Q" value:

- 1) carbon dioxide, solid (dry ice), UN 1845;
- 2) those where columns 11 and 13 of Table 3-1 indicate "No limit";
- 3) those with the same UN number, packing group, and physical state (i.e. solid or liquid), providing they are the only dangerous goods in the package and the total net quantity does not exceed the maximum net quantity according to Table 3-1.

An outer packaging containing Division 6.2 (Infectious Substances) may contain material for refrigeration, or freezing or packaging material such as absorbent material.

Note.— For packages containing radioactive material, see 9.1.3.

1.1.10 Inner packagings must be so packed, secured or cushioned in an outer packaging in such a way that, under normal conditions of transport, they cannot break, be punctured or leak their contents into the outer packaging. Inner packagings containing liquids must be packaged with their closures upward and placed within outer packagings consistent with the orientation markings prescribed in 5.3.2.12 b) of these Instructions. Inner packagings that are liable to break or be punctured easily, such as those made of glass, porcelain or stoneware or of certain plastic material, must be secured in outer packagings with suitable cushioning material. Any leakage of the contents must not substantially impair the protective properties of the cushioning material or of the outer packaging.

≠ 1.1.10.1 Where an outer packaging of a combination packaging has been successfully tested with different types of inner packagings, a variety of such different inner packagings may also be assembled in this outer packaging. In addition, provided an equivalent level of performance is maintained, the following variations in inner packagings are allowed without further testing of the package:

- a) inner packagings of equivalent or smaller size may be used provided:
 - 1) the inner packagings are of similar design to the tested inner packagings (e.g. shape — round, rectangular);
 - 2) the material of construction of the inner packagings (glass, plastics, metal, etc.) offers resistance to impact and stacking forces equal to or greater than that of the originally tested inner packaging;
 - 3) the inner packagings have the same or smaller openings and the closure is of similar design (screw cap, friction lid, etc.);
 - 4) sufficient additional cushioning material is used to take up void spaces and to prevent significant movement of the inner packagings; and
 - 5) inner packagings are oriented within the outer packaging in the same manner as in the tested package; and
- b) a lesser number of the tested inner packagings, or of the alternative types of inner packagings identified in a) above, may be used provided sufficient cushioning is added to fill the void space(s) and to prevent significant movement of the inner packagings.

+ 1.1.10.2 Use of supplementary packagings within an outer packaging (e.g. an intermediate packaging or a receptacle inside a required inner packaging) additional to what is required by the packing instructions is permitted provided all relevant requirements are met, including those of 4;1.1.2, and, if appropriate, suitable cushioning is used to prevent movement within the packaging.

1.1.11 The nature and the thickness of the outer packaging must be such that friction during transport does not generate any heat likely to alter dangerously the chemical stability of the contents.

1.1.12 Venting of packagings to reduce internal pressure, which may develop by the evolution of gas from the contents, is not permitted for air transport, except as otherwise specified in these Instructions.

1.1.13 Except as provided in 1.1.13.1, combination packagings having inner packagings containing liquid dangerous goods must be packed so that the closures on the inner packagings are upward and the upright position of the package must be indicated on it by the "Package orientation" label described in 5;3.2.12 b). The words "This side up" or "This end up" may also be displayed on the top cover of the package.

1.1.13.1 Orientation arrows are not required on outer packagings containing:

- a) dangerous goods in inner packagings each containing not more than 120 mL with sufficient absorbent material between the inner and outer packagings to completely absorb the liquid contents;
- b) Division 6.2 infectious substances in primary receptacles each containing not more than 50 mL; or
- c) dangerous goods in gas tight inner packagings such as tubes, bags or vials which are opened by breaking or puncturing. Each inner packaging must not contain more than 500 mL.

1.1.14 Except as provided in 5;3.5.1.1 a), a package must be of such size that there is adequate space to affix all necessary labels and markings.

1.1.15 An empty packaging that has contained a dangerous substance must be treated in the same manner as is required by these Instructions for a package filled with that substance unless adequate measures have been taken to nullify any hazard.

Note.— Purging and thorough flushing of the packaging with a neutralizing agent is an acceptable method of nullifying the hazard.

1.1.16 Packagings tested as prescribed in 6;4.5 and marked with the hydraulic test pressure prescribed in 6;2.1.1 d) 1) must be filled only with a liquid having a vapour pressure:

- a) such that the total gauge pressure in the packaging (i.e. the vapour pressure of the filling substance plus the partial pressure of air or other inert gases, less 100 kPa) at 55°C, determined on the basis of a maximum degree of filling in accordance with 1.1.5 and a filling temperature of 15°C, will not exceed two-thirds of the marked test pressure; or
- b) at 50°C less than four-sevenths of the sum of the marked test pressure plus 100 kPa; or
- c) at 55°C less than two-thirds of the sum of the marked test pressure plus 100 kPa (see Table 4-1).

However, where the packaging is selected on the basis of 1.1.16 a) the hydraulic test pressure marked in accordance with 6;2.1.1 d) 1) must be not less than 100 kPa (not less than 80 kPa for liquids in Packing Group III of Class 3 or Division 6.1).

1.1.17 Packagings used for solids which may become liquid at temperatures encountered during air transport must also be capable of containing that substance in the liquid state.

Note.— Packagings for solids (both inner and single) which may be permitted by the applicable packing instruction should not be used if they are unsuitable for containing liquids (e.g. paper or plastic bags as inner packagings, unlined fibre drums as single packagings, should not be used).

Table 4-1. Examples of required marked test pressures calculated as in 1.1.16 c)

UN No.	Name	Class	Packing Group	V_{p55} (kPa)	$V_{p55} \times 1.5$ (kPa)	$(V_{p55} \times 1.5)$ minus 100 (kPa)	Required minimum test pressure (gauge) under 6;4.5.3 c) (kPa)	Minimum test pressure (gauge) to be marked on the packaging (kPa)
2056	Tetrahydrofuran	3	II	70	105	5	100	100
2247	n-Decane	3	III	1.4	2.1	-97.9	100	100
1593	Dichloromethane	6.1	III	164	246	146	146	150
1155	Diethyl ether	3	I	199	299	199	199	250

Note 1.— For pure liquids the vapour pressure at 55°C (V_{p55}) can often be obtained from scientific tables.

Note 2.— The maximum vapour pressures in 1.1.16 b) and c) refer to the basis of the formula while the minimum hydraulic test pressure in the last sentence of 1.1.16 refers to the aircraft altitude.

Note 3.— This table refers to the use of 1.1.16 c) only, which means that the marked test pressure must exceed 1.5 times the vapour pressure at 55°C less 100 kPa. When, for example, the test pressure for n-Decane is determined according to 6;4.5.3 a) the minimum marked test pressure of 80 kPa applies.

Note 4.— For Diethyl ether the required minimum test pressure under 6;4.5.4 is 250 kPa.

1.1.18 Every packaging intended to contain liquids must successfully undergo a suitable leakproofness test and be capable of meeting the appropriate test level indicated in 6;4.4.2:

- a) before it is first used for transport;
- b) after remanufacturing or reconditioning, before it is reused for transport.

For this test, packagings need not have their own closures fixed.

The inner receptacle of composite packagings may be tested without the outer packaging provided the test results are not affected. This test is not necessary for inner packagings of combination packagings.

1.1.19 The closures of packagings containing wetted or diluted substances must be such that the percentage of liquid (water, solvent or phlegmatizer) does not fall below the prescribed limits during transport.

1.1.20 For plastic drums and jerricans, rigid plastic IBCs and composite IBCs with plastic inner receptacles, unless otherwise approved by the appropriate national authority, the period of use permitted for the transport of dangerous goods must be not more than five years from the date of manufacture of the receptacles, except where a shorter period of use is prescribed because of the nature of the substance to be transported.

1.1.21 Where ice is used as a coolant it must not affect the integrity of the packaging.

1.2 PACKING GROUP

Unless otherwise provided for, the specification packagings (i.e. those listed in Table 6-2) detailed in the packing instructions must meet the performance test requirements of the relevant packing group shown in column 8 of Table 3-1 for the particular substance or article.

1.3 TRANSITIONAL PACKAGING ARRANGEMENTS FOR RADIOACTIVE MATERIAL

For the arrangements for the use of packagings for radioactive material manufactured under earlier requirements, see 6;7.24.

1.4 SALVAGE PACKAGINGS

1.4.1 Damaged, defective, leaking or non-conforming packages, or dangerous goods that have spilled or leaked may be transported in salvage packagings (see 1;3.1.1) meeting the requirements of 1.4.2 and 6;4.8. These salvage packagings may be used provided that appropriate measures are taken to prevent excessive movement of the damaged or leaking packages within the salvage packaging and that when the salvage packaging contains liquids, sufficient absorbent material is added to eliminate the presence of free liquid. Prior approval from the appropriate national authority must be obtained to ship salvage packagings.

1.4.2 Salvage packagings must be single packagings of a material resistant to any chemical or other action of the leaking or spilled dangerous goods. Not more than one damaged, defective or leaking package of dangerous goods may be packed in any one of such single packagings.

1.4.3 Damaged, defective or leaking packages of dangerous goods of Classes 1, 2 and 7 and Division 6.2 (other than Clinical waste and Medical waste falling under UN 3291) must not be transported in salvage packagings.

1.4.4 Damaged, defective or leaking packages of self-reactive substances of Division 4.1 or substances of Division 5.2 must not be transported in metal salvage packagings meeting Packing Group I requirements.

Chapter 2

GENERAL

2.1 Each of the succeeding Chapters of this Part is devoted to the specific packing instructions applicable to an individual class of dangerous goods. In some cases the Chapters start with general requirements which apply to all goods in that class.

2.2 The Dangerous Goods List (Table 3-1) shows for each article or substance, in columns 10 and 12, the number of the packing instruction that must be used.

2.3 Each instruction shows, where applicable, the acceptable single and combination packagings. For combination packagings, tables show the acceptable outer packagings and associated inner packagings with the maximum net quantity permitted in each inner packaging. Where provisions for particular articles or substances apply, a table shows the inner packagings with associated quantity limitations, the permitted quantity per package and, where applicable, an indication if single packagings are permitted. Where appropriate, additional packing requirements are also indicated at the end of a packing instruction. These additional packing requirements may impose a higher standard of packaging than would normally apply to the packing group, or may require specific packaging considerations.

2.4 Unless otherwise specified, each packaging must conform to the applicable requirements of Part 6. Generally packing instructions do not provide guidance on compatibility and the user must not select a packaging without checking that the substance is compatible with the packaging material selected (e.g. most fluorides are unsuitable for glass receptacles). Where glass receptacles are permitted in the packing instructions porcelain, earthenware and stoneware packagings are also allowed.

2.5 The following packagings must not be used when the substances being transported are liable to become liquid during transport:

Drums:	1D and 1G
Boxes:	4C1, 4C2, 4D, 4F, 4G and 4H1
Bags:	5L1, 5L2, 5L3, 5H1, 5H2, 5H3, 5H4, 5M1 and 5M2
Composite packagings:	6HC, 6HD2, 6HG1, 6HG2, 6HD1, 6PC, 6PD1, 6PD2, 6PG1, 6PG2 and 6PH1.

2.6 Where the packing instructions in this Part authorize the use of a particular type of outer packaging (e.g. 4G, 1A2), packagings bearing the same packaging identification code followed by the letters "V", "U" or "W" marked in accordance with the requirements of 6;4.1.7 h) (e.g. 4GV, 4GU or 4GW; 1A2V, 1A2U or 1A2W) may also be used under the same conditions and limitations applicable to the use of that type of packaging according to the relevant packing instruction. For example, a combination packaging marked with the packaging code "4GV" may be used whenever a combination packaging marked "4G" is authorized, provided the requirements in the relevant packing instruction regarding types of inner packagings and quantity limitations are respected.

2.7 Cylinders may be used for liquids and solids when indicated in a packing instruction. The cylinder must meet the standards set out below.

2.7.1 Unless otherwise indicated in these Instructions, cylinders conforming to:

- a) the applicable requirements of 6;5; or
- b) the national or international standards on the design, construction, testing, manufacturing and inspection, as applied by the country in which the cylinders are manufactured, provided that the provisions of 2.7 and 6;5.3.3 are met.

2.7.2 Every design type of cylinder must be approved by the competent authority of the country of manufacture or as indicated in 6;5.

2.7.3 Unless otherwise indicated, cylinders having a minimum test pressure of 0.6 MPa must be used.

2.7.4 Unless otherwise indicated, cylinders may be provided with an emergency pressure relief device designed to avoid bursting in case of overfill or fire accidents.

Cylinder valves must be designed and constructed in such a way that they are inherently able to withstand damage without release of the contents or must be protected from damage which could cause inadvertent release of the contents of the cylinder, by one of the methods as given in 4.1.1.9 a) to e).

2.7.5 The level of filling must not exceed 95 per cent of the capacity of the cylinder at 50°C. Sufficient ullage (outage) must be left to ensure that the cylinder will not be liquid full at a temperature of 55°C.

2.7.6 Unless otherwise indicated cylinders must be subjected to a periodic inspection and test every 5 years. The periodic inspection must include an external examination, an internal examination or alternative method as approved by the competent authority, a pressure test or equivalent effective non-destructive testing with the agreement of the competent authority including an inspection of all accessories (e.g. tightness of valves, emergency relief valves or fusible elements). Cylinders must not be filled after they become due for periodic inspection and test but may be transported after the expiry of the time limit. Cylinder repairs must meet the requirements of 4.1.1.11.

2.7.7 Prior to filling, the filler must perform an inspection of the cylinder and ensure that the cylinder is authorized for the substances to be transported and that the provisions of these Instructions have been met. Shut-off valves must be closed after filling and remain closed during transport. The shipper must verify that the closures and equipment are not leaking.

2.7.8 Refillable cylinders must not be filled with a substance different from that previously contained unless the necessary operations for change of service have been performed.

2.7.9 Marking of cylinders for liquids and solids according to 2.7 (not conforming to the requirements of 6;5) must be in accordance with the requirements of the competent authority of the country of manufacturing.

2.8 The appropriate authority of the State of Origin may approve the use of a packaging alternative to those provided in a particular packing instruction indicated in Table 3-1 for listed dangerous goods provided:

- a) the alternative packaging complies with the general requirements of 4;1;
- b) when the particular packaging instruction indicated in Table 3-1 specifies packagings which are listed in Tables 6-2 and 6-3, the alternative packaging must meet the applicable requirements of Part 6;
- c) for the type of alternative packaging, the expressions "Not used in these Instructions" or "Specialized use only" do not appear in Table 6-2 under the "Paragraph" column heading;
- d) the appropriate authority of the State of Origin determines that the alternative packaging achieves at least the same level of safety as if the substance were packed in accordance with a method specified in the particular packing instruction indicated in Table 3-1;
- e) the maximum net quantity of dangerous goods in the packaging does not exceed the quantity specified in the appropriate column of Table 3-1; and
- f) a copy of the document of approval accompanies each consignment.

2.9 UNPACKAGED ARTICLES OTHER THAN CLASS 1 ARTICLES

The appropriate authority of the State of Origin and the State of the Operator may approve the transport of large and robust articles which cannot be packaged in accordance with the requirements of 6;1 to 6;4, where they have to be transported empty, uncleaned and unpackaged, providing they comply with the requirements in Part S-4, Chapter 3 of the Supplement.

Chapter 3

CLASS 1 — EXPLOSIVES

*Parts of this Chapter are affected by State Variation BE 2, DK 2, HR 5;
see Table A-1*

3.1 PACKING GROUP

Unless otherwise specified in these Instructions, packagings must conform to the requirements of 6;1, 6;2, 6;3 and 6;4 and must meet the test requirements of 6;4 for Packing Group II.

3.2 GENERAL REQUIREMENTS

3.2.1 The general packing requirements of 4;1 must be met.

3.2.2 All packagings for Class 1 explosives must be so designed and constructed that:

- a) they will protect the explosives, prevent them from escaping and cause no increase in the risk of unintended ignition or initiation when subjected to normal conditions of transport including foreseeable changes in temperature, humidity and pressure;
- b) the complete package can be handled safely in normal conditions of transport; and
- c) the packages will withstand any loading imposed on them by foreseeable stacking to which they will be subject during transport so that they do not add to the risk presented by the explosives, the containment function of the packagings is not harmed, and they are not distorted in a way or to an extent which will reduce their strength or cause instability of a stack.

3.2.3 All explosive substances and articles, as prepared for transport, must have been classified in accordance with the procedures detailed in 2;1.5.

3.3 GENERAL PACKING PROVISIONS

3.3.1 The general provisions detailed below are in addition to those in Part 4, Chapter 1.

3.3.1.1 The closure device of packagings containing liquid explosives must ensure a double protection against leakage.

3.3.1.2 The closure device of metal drums must include a suitable gasket; if a closure device includes a screw-thread, the ingress of explosive substances into the screw-thread must be prevented.

3.3.1.3 Packagings for water soluble substances must be water-resistant.

3.3.1.4 When the packaging includes a double envelope filled with water which may freeze during transport, a sufficient quantity of an anti-freeze agent must be added to the water to prevent freezing. Anti-freeze that could create a fire hazard because of its inherent flammability must not be used.

3.3.1.5 Nails, staples and other closure devices made of metal without protective covering must not penetrate to the inside of the outer packaging unless the inner packaging adequately protects the explosives against contact with the metal.

3.3.1.6 Inner packagings, fittings and cushioning materials and the placing of explosive substances or articles in packages must be accomplished in a manner which prevents the explosive substances or articles from becoming loose in the outer packaging under normal conditions of transport. Metallic components of articles must be prevented from making contact with metal packagings. Articles containing explosive substances not enclosed in an outer casing must be separated from each other in order to prevent friction and impact. Padding, trays, partitioning in the inner or outer packaging, mouldings or receptacles may be used for this purpose.

3.3.1.7 Packagings must be made of materials compatible with, and impermeable to, the explosives contained in the package, so that neither interaction between the explosives and the packaging materials, nor leakage, causes the explosive to become unsafe to transport, or the hazard division or compatibility group to change.

3.3.1.8 The ingress of explosive substances into the recesses of seamed metal packagings must be prevented.

3.3.1.9 Plastic packagings must not be liable to generate or accumulate sufficient static electricity so that a discharge could cause the packaged explosive substances or articles to initiate, ignite or function.

3.3.1.10 Explosive substances must not be packed in inner or outer packagings where the differences in internal and external pressures, due to thermal or other effects, could cause an explosion or rupture of the package.

3.3.1.11 Whenever loose explosive substances or the explosive substance of an uncased or partly cased article may come into contact with the inner surface of metal packagings (1A2, 1B2, 4A, 4B and metal receptacles), the metal packaging must be provided with an inner liner or coating (see 1.1.3).

3.3.1.12 Packing Instruction 101 may be used for any explosive provided the package has been approved by an appropriate national authority regardless of whether the packaging complies with the packing instruction assignment in the Dangerous Goods List.

3.3.1.13 Electro-explosive devices must be adequately protected against electro-magnetic radiation and stray currents.

3.3.1.14 Large and robust explosive articles, normally intended for military use, without their means of initiation or without their means of initiation containing at least two effective protective features, may be carried unpackaged. When such articles have propelling charges or are self-propelled, their ignition systems must be protected against stimuli encountered during normal conditions of transport. A negative result in Test Series 4 on an unpackaged article indicates that the article can be considered for transport unpackaged. Such unpackaged articles may be fixed to cradles or contained in crates or other suitable handling, storage or launching devices in such a way that they will not become loose during normal conditions of transport.

3.3.1.14.1 Where such large explosive articles are, as part of their operational safety and suitability tests, subjected to test regimes that meet the intentions of these Instructions and such tests have been successfully undertaken, the appropriate national authority may approve such articles to be transported under these Instructions.

Note 1.— The term receptacle used in the Inner and Intermediate packaging columns of this table includes boxes, bottles, cans, drums, jars and tubes, including any means of closure.

Note 2.— Reels are devices made of plastics, wood, fibreboard, metal or other suitable material comprising a central spindle with, or without, side walls at each end of the spindle. Articles and substances can be wound onto the spindle and may be retained by side walls.

Note 3.— Trays are sheets of metal, plastics, wood, fibreboard or other suitable material which are placed in the inner, intermediate or outer packaging and achieve a close-fit in such packaging. The surface of the tray may be shaped so that packagings or articles can be inserted, held secure and separated from each other.

3.4 PACKING INSTRUCTIONS

Packing Instruction 101

Inner packagings

Intermediate packagings

Outer packagings

As specified by the appropriate national authority.

The State's distinguishing sign for motor vehicles in international traffic of the country for which the authority acts must be marked on the dangerous goods transport document as follows: "Packaging approved by the competent authority of ..."

Note.— In this instance the term "competent authority" is used for intermodal compatibility; it refers to the appropriate national authority.

Packing Instruction 114

a) solid wetted

Inner packagings

Bags

plastics
textile
woven plastics

Receptacles

metal
plastics
wood

Intermediate packagings

Bags

plastics
textile, plastic coated or
lined

Receptacles

metal
plastics

Dividing partitions

wood

Outer packagings

Boxes

fibreboard (4G)
natural wood, ordinary (4C1)
natural wood, with siftproof walls (4C2)
other metal (4N)
plywood (4D)
reconstituted wood (4F)
solid plastics (4H2)
steel (4A)

Drums

aluminium (1B1, 1B2)
fibre (1G)
other metal (1N1, 1N2)
plastics (1H1, 1H2)
plywood (1D)
steel (1A1, 1A2)

PARTICULAR PACKING REQUIREMENTS OR EXCEPTIONS:

- For UN 0077, 0234, 0235 and 0236, packagings must be lead-free.
- For UN 0342, inner packagings are not required when metal (1A1, 1A2, 1B1, 1B2, 1N1 or 1N2) or plastic (1H1 or 1H2) drums are used as outer packagings.
- Intermediate packagings are not required if leakproof removable head drums are used as the outer packaging.

b) solid dry

Inner packagings

Bags

paper, kraft
plastics
textile, siftproof
woven plastics, siftproof

Receptacles

fibreboard
metal
paper
plastics
wood
woven plastics, siftproof

Intermediate packagings

Not necessary

Outer packagings

Boxes

fibreboard (4G)
natural wood, ordinary (4C1)
natural wood, with siftproof walls (4C2)
plywood (4D)
reconstituted wood (4F)

Drums

aluminium (1B1, 1B2)
fibre (1G)
other metal (1N1, 1N2)
plastics (1H1, 1H2)
plywood (1D)
steel (1A1, 1A2)

PARTICULAR PACKING REQUIREMENTS OR EXCEPTIONS:

- For UN 0077, 0132, 0234, 0235 and 0236, packagings must be lead-free.
- For UN 0508 and 0509, metal packagings must not be used.
- For UN 0160 and 0161, when metal drums (1A1, 1A2, 1B1, 1B2, 1N1 or 1N2) are used as the outer packaging, metal packagings must be so constructed that the risk of explosion, by reason of increase in internal pressure from internal or external causes, is prevented.
- For UN 0160 and 0161, inner packagings are not required if drums are used as the outer packaging.

Packing Instruction 130

Inner packagings

Not necessary

Intermediate packagings

Not necessary

Outer packagings

Boxes

aluminium (4B)
 expanded plastics (4H1)
 fibreboard (4G)
 natural wood, ordinary (4C1)
 natural wood, with siftproof walls (4C2)
 other metal (4N)
 plywood (4D)
 reconstituted wood (4F)
 solid plastics (4H2)
 steel (4A)

Drums

aluminium (1B1, 1B2)
 fibre (1G)
 other metal (1N1, 1N2)
 plastics (1H1, 1H2)
 plywood (1D)
 steel (1A1, 1A2)

PARTICULAR PACKING REQUIREMENTS OR EXCEPTIONS:

- The following applies to UN 0006, 0009, 0010, 0015, 0016, 0018, 0019, 0034, 0035, 0038, 0039, 0048, 0056, 0137, 0138, 0168, 0169, 0171, 0181, 0182, 0183, 0186, 0221, 0238, 0243, 0244, 0245, 0246, 0254, 0280, 0281, 0286, 0287, 0297, 0299, 0300, 0301, 0303, 0321, 0328, 0329, 0344, 0345, 0346, 0347, 0362, 0363, 0370, 0412, 0424, 0425, 0434, 0435, 0436, 0437, 0438, 0451, 0459 and 0488. Large and robust explosive articles, normally intended for military use, without their means of initiation or with their means of initiation containing at least two effective protective features, may be carried unpackaged. When such articles have propelling charges or are self-propelled, their ignition systems must be protected against stimuli encountered during normal conditions of transport. A negative result in Test Series 4 on an unpackaged article indicates that the article can be considered for transport unpackaged. Such unpackaged articles may be fixed to cradles or contained in crates or other suitable handling, storage or launching devices in such a way that they will not become loose during normal conditions of transport. Where such large explosive articles are as part of their operational safety and suitability tests subjected to test regimes that meet the intentions of these Instructions and such tests have been successfully undertaken, the appropriate national authority may approve such articles to be transported under these Instructions.
- For UN 0457, 0458, 0459 and 0460, whenever loose explosive substances or the explosive substance of an uncased or partly cased article may come into contact with the inner surface of metal packagings (1A2, 1B2, 4A, 4B and metal receptacles), the metal packaging must be provided with an inner liner or coating.

Packing Instruction 131

Inner packagings

Bags
 paper
 plastics
 Receptacles
 fibreboard
 metal
 plastics
 wood
 Reels

Intermediate packagings

Not necessary

Outer packagings

Boxes
 aluminium (4B)
 fibreboard (4G)
 natural wood, ordinary (4C1)
 natural wood, with siftproof walls (4C2)
 other metal (4N)
 + plastics, solid (4H2)
 plywood (4D)
 reconstituted wood (4F)
 steel (4A)
 Drums
 aluminium (1B1, 1B2)
 fibre (1G)
 plastics (1H1, 1H2)
 other metal (1N1, 1N2)
 plywood (1D)
 steel (1A1, 1A2)

PARTICULAR PACKING REQUIREMENTS OR EXCEPTIONS:

— For UN 0029, 0267 and 0455, bags and reels must not be used as inner packagings.

Packing Instruction 133

Inner packagings

Receptacles
 fibreboard
 metal
 plastics
 wood
 Trays, fitted with dividing partitions
 fibreboard
 plastics
 wood

Intermediate packagings

Receptacles
 fibreboard
 metal
 plastics
 wood

Outer packagings

Boxes
 aluminium (4B)
 fibreboard (4G)
 natural wood, ordinary (4C1)
 natural wood, with siftproof walls (4C2)
 other metal (4N)
 plywood (4D)
 reconstituted wood (4F)
 solid plastics (4H2)
 steel (4A)

PARTICULAR PACKING REQUIREMENTS OR EXCEPTIONS:

— Receptacles are only required as intermediate packagings when the inner packagings are trays.
 — For UN 0043, 0212, 0225, 0268 and 0306, trays must not be used as inner packagings.

Packing Instruction 134

Inner packagings

Bags
 water-resistant
 Receptacles
 fibreboard
 metal
 plastics
 wood
 Sheets
 fibreboard, corrugated
 Tubes
 fibreboard

Intermediate packagings

Not necessary

Outer packagings

Boxes
 aluminium (4B)
 fibreboard (4G)
 natural wood, ordinary (4C1)
 natural wood, with siftproof walls (4C2)
 other metal (4N)
 plywood (4D)
 reconstituted wood (4F)
 solid plastics (4H2)
 steel (4A)
 Drums
 aluminium (1B1, 1B2)
 fibre (1G)
 plastics (1H1, 1H2)
 other metal (1N1, 1N2)
 plywood (1D)
 steel (1A1, 1A2)

Packing Instruction 135

Inner packagings

Bags
 paper
 plastics
 Receptacles
 fibreboard
 metal
 plastics
 wood
 Sheets
 paper
 plastics

Intermediate packagings

Not necessary

Outer packagings

Boxes
 aluminium (4B)
 expanded plastics (4H1)
 fibreboard (4G)
 natural wood, ordinary (4C1)
 natural wood, with siftproof walls (4C2)
 other metal (4N)
 plywood (4D)
 reconstituted wood (4F)
 solid plastics (4H2)
 steel (4A)
 Drums
 aluminium (1B1, 1B2)
 fibre (1G)
 other metal (1N1, 1N2)
 plastics (1H1, 1H2)
 plywood (1D)
 steel (1A1, 1A2)

Packing Instruction 136

Inner packagings

Bags

plastics
textile

Boxes

fibreboard
plastics
wood

Dividing partitions in the
outer packagings

Intermediate packagings

Not necessary

Outer packagings

Boxes

aluminium (4B)
fibreboard (4G)
natural wood, ordinary (4C1)
natural wood, with siftproof walls (4C2)
other metal (4N)
plywood (4D)
reconstituted wood (4F)
solid plastics (4H2)
steel (4A)

Drums

aluminium (1B1, 1B2)
fibre (1G)
other metal (1N1, 1N2)
plastics (1H1, 1H2)
plywood (1D)
steel (1A1, 1A2)

Packing Instruction 137

Inner packagings

Bags

plastics

Boxes

fibreboard
wood

Tubes

fibreboard
metal
plastics

Dividing partitions in the
outer packagings

Intermediate packagings

Not necessary

Outer packagings

Boxes

aluminium (4B)
fibreboard (4G)
natural wood, ordinary (4C1)
natural wood, with siftproof walls (4C2)
other metal (4N)
+ plastics, solid (4H2)
plywood (4D)
reconstituted wood (4F)
steel (4A)

PARTICULAR PACKING REQUIREMENTS OR EXCEPTIONS:

- For UN 0059, 0439, 0440 and 0441, when the shaped charges are packed singly, the conical cavity must face downwards and the package marked "THIS SIDE UP". When the shaped charges are packed in pairs, the conical cavities must face inwards to minimize the jetting effect in the event of accidental initiation.

Packing Instruction 138

Inner packagings

Bags
plastics

Intermediate packagings

Not necessary

Outer packagings

Boxes
aluminium (4B)
fibreboard (4G)
natural wood, ordinary (4C1)
natural wood, with siftproof walls (4C2)
other metal (4N)
plywood (4D)
reconstituted wood (4F)
solid plastics (4H2)
steel (4A)

Drums
aluminium (1B1, 1B2)
fibre (1G)
other metal (1N1, 1N2)
plastics (1H1, 1H2)
plywood (1D)
steel (1A1, 1A2)

PARTICULAR PACKING REQUIREMENTS OR EXCEPTIONS:

— If the ends of the articles are sealed, inner packagings are not necessary.

Packing Instruction 139

Inner packagings

Bags
plastics
Receptacles
fibreboard
metal
plastics
wood
Reels
Sheets
paper
plastics

Intermediate packagings

Not necessary

Outer packagings

Boxes
aluminium (4B)
fibreboard (4G)
natural wood, ordinary (4C1)
natural wood, with siftproof walls (4C2)
other metal (4N)
plywood (4D)
reconstituted wood (4F)
solid plastics (4H2)
steel (4A)

Drums
aluminium (1B1, 1B2)
fibre (1G)
other metal (1N1, 1N2)
plastics (1H1, 1H2)
plywood (1D)
steel (1A1, 1A2)

PARTICULAR PACKING REQUIREMENTS OR EXCEPTIONS:

— For UN 0065, 0102, 0104, 0289 and 0290, the ends of the detonating cord must be sealed, for example by a plug firmly fixed so that the explosive cannot escape. The ends of "**Cord, detonating, flexible**", must be fastened securely.

— For UN 0065 and 0289, inner packagings are not required when they are in coils.

Packing Instruction 140

Inner packagings

Bags
 plastics
 Reels
 Sheets
 paper, kraft
 plastics
 Receptacles
 wood

Intermediate packagings

Not necessary

Outer packagings

Boxes
 aluminium (4B)
 fibreboard (4G)
 natural wood, ordinary (4C1)
 natural wood, with siftproof walls (4C2)
 other metal (4N)
 plywood (4D)
 reconstituted wood (4F)
 solid plastics (4H2)
 steel (4A)

Drums
 aluminium (1B1, 1B2)
 fibre (1G)
 other metal (1N1, 1N2)
 plastics (1H1, 1H2)
 plywood (1D)
 steel (1A1, 1A2)

PARTICULAR PACKING REQUIREMENTS OR EXCEPTIONS:

- If the ends of UN 0105 are sealed, no inner packagings are required.
- For UN 0101, the packaging must be siftproof except when the fuse is covered by a paper tube and both ends of the tube are covered with removable caps.
- For UN 0101, steel, aluminium or other metal boxes or drums must not be used.

Packing Instruction 141

Inner packagings

Receptacles
 fibreboard
 metal
 plastics
 wood
 Trays, fitted with dividing partitions
 plastics
 wood
 Dividing partitions in the
 outer packagings

Intermediate packagings

Not necessary

Outer packagings

Boxes
 aluminium (4B)
 fibreboard (4G)
 natural wood, ordinary (4C1)
 natural wood, with siftproof walls (4C2)
 other metal (4N)
 plywood (4D)
 reconstituted wood (4F)
 solid plastics (4H2)
 steel (4A)

Drums
 aluminium (1B1, 1B2)
 fibre (1G)
 other metal (1N1, 1N2)
 plastics (1H1, 1H2)
 plywood (1D)
 steel (1A1, 1A2)

Packing Instruction 142

<i>Inner packagings</i>	<i>Intermediate packagings</i>	<i>Outer packagings</i>
Bags paper plastics Receptacles fibreboard metal plastics wood Sheets paper Trays, fitted with dividing partitions plastics	Not necessary	Boxes aluminium (4B) fibreboard (4G) natural wood, ordinary (4C1) natural wood, with siftproof walls (4C2) other metal (4N) plywood (4D) reconstituted wood (4F) solid plastics (4H2) steel (4A) Drums aluminium (1B1, 1B2) fibre (1G) other metal (1N1, 1N2) plastics (1H1, 1H2) plywood (1D) steel (1A1, 1A2)

Packing Instruction 143

<i>Inner packagings</i>	<i>Intermediate packagings</i>	<i>Outer packagings</i>
Bags paper, kraft plastics textile textile, rubberized Receptacles fibreboard metal plastics wood Trays, fitted with dividing partitions plastics	Not necessary	Boxes aluminium (4B) fibreboard (4G) natural wood, ordinary (4C1) natural wood, with siftproof walls (4C2) other metal (4N) plywood (4D) reconstituted wood (4F) solid plastics (4H2) steel (4A) Drums aluminium (1B1, 1B2) fibre (1G) other metal (1N1, 1N2) plastics (1H1, 1H2) plywood (1D) steel (1A1, 1A2)

PARTICULAR PACKING REQUIREMENTS OR EXCEPTIONS:

- For UN 0271, 0272, 0415 and 0491, when metal packagings are used, metal packagings must be so constructed that the risk of explosion, by reason of increase in internal pressure from internal or external causes, is prevented.
- Instead of the above inner and outer packagings, composite packagings (6HH2) (plastic receptacle with outer solid box) may be used.

Chapter 4

CLASS 2 — GASES

Parts of this Chapter are affected by State Variations CA 10, US 6, US 15; see Table A-1

4.1 SPECIAL PACKING PROVISIONS FOR DANGEROUS GOODS OF CLASS 2

4.1.1 General requirements

4.1.1.1 This section provides general requirements applicable to the use of cylinders and closed cryogenic receptacles for the transport of Class 2 gases (e.g. UN 1072 **Oxygen, compressed**). Cylinders and closed cryogenic receptacles must be constructed and closed so as to prevent any loss of contents which might be caused under normal conditions of transport, including by vibration, or by changes in temperature, humidity or pressure (resulting from change in altitude, for example).

≠ 4.1.1.2 Parts of cylinders and closed cryogenic receptacles that are in direct contact with dangerous goods must not be affected or weakened by those dangerous goods and must not cause a dangerous effect (e.g. catalysing a reaction or reacting with the dangerous goods). In addition to the requirements specified in the relevant packing instruction, which take precedence, the applicable provisions of ISO 11114-1:2012 and ISO 11114-2:2000 must be met.

4.1.1.3 Cylinders and closed cryogenic receptacles, including their closures, must be selected that are able to contain a gas or a mixture of gases according to the requirements of 6;5.1.2 and the requirements of the specific packing instructions of this Part.

4.1.1.4 Refillable cylinders must not be filled with a gas or gas mixture different from that previously contained unless the necessary operations for change of gas service have been performed. The change of service for compressed and liquefied gases must be in accordance with ISO 11621:1997, as applicable. In addition, a cylinder that previously contained a Class 8 corrosive substance or a substance of another class with a corrosive subsidiary risk must not be authorized for the transport of a Class 2 substance unless the necessary inspection and testing as specified in 6;5.1.6 have been performed.

4.1.1.5 Prior to filling, the filler must perform an inspection of the cylinder or closed cryogenic receptacle and ensure that the cylinder or closed cryogenic receptacle is authorized for the gas to be transported and that the provisions of these instructions have been met. Shut-off valves must be closed after filling and remain closed during transport. The shipper must verify that the closures and equipment are not leaking.

4.1.1.6 Cylinders and closed cryogenic receptacles must be filled according to the working pressures, filling ratios and provisions specified in the appropriate packing instruction for the specific substance. Reactive gases and gas mixtures must be filled to a pressure such that if complete decomposition of the gas occurs, the working pressure of the cylinder must not be exceeded.

4.1.1.7 Cylinders and closed cryogenic receptacles, including their closures, must conform to the design, construction, inspection and testing requirements detailed in 6;5. When outer packagings are prescribed, the cylinders must be firmly secured therein. Unless otherwise specified in the detailed packing instructions, one or more inner packagings may be enclosed in an outer packaging.

4.1.1.8 Valves must be designed and constructed in such a way that they are inherently able to withstand damage without release of the contents or must be protected from damage, which could cause inadvertent release of the contents of the cylinder and closed cryogenic receptacle, by one of the following methods:

- a) Valves are placed inside the neck of the cylinder and closed cryogenic receptacle and protected by a threaded plug or cap;
- b) Valves are protected by caps. Caps must possess vent holes of a sufficient cross-sectional area to evacuate the gas if leakage occurs at the valves;
- c) Valves are protected by shrouds or guards;
- d) Not used; or
- e) Cylinders and closed cryogenic receptacles are transported in an outer packaging. The packaging as prepared for transport must be capable of meeting the drop test specified in 6;4.3 at the Packing Group I performance level.

For cylinders and closed cryogenic receptacles with valves as described in b) and c), the requirements of ISO 11117:1998 must be met; for valves with inherent protection, the requirements of Annex A of ISO 10297:2006 must be met. For metal hydride storage systems, the valve protection requirements specified in ISO 16111:2008 must be met.

4.1.1.9 Non-refillable cylinders and closed cryogenic receptacles must:

- a) be transported in an outer packaging, such as a box, or crate, or in shrink-wrapped trays or stretch-wrapped trays;
- b) not be repaired after being put into service.

4.1.1.10 Refillable cylinders, other than closed cryogenic receptacles, must be periodically inspected according to the provisions of 6;5.1.6 and Packing Instruction 200 or 214. Cylinders and closed cryogenic receptacles must not be filled after they become due for periodic inspection but may be transported after the expiry of the time limit.

4.1.1.11 Repairs must be consistent with the fabrication and testing requirements of the applicable design and construction standards and are only permitted as indicated in the relevant periodic inspection standards specified in 6;5.2.4. Cylinders, other than the jacket of closed cryogenic receptacles, must not be subjected to repairs of any of the following:

- a) weld cracks or other weld defects;
- b) cracks in walls;
- c) leaks or defects in the material of the wall, head or bottom.

4.1.1.12 Cylinders and closed cryogenic receptacles must not be offered for filling:

- a) when damaged to such an extent that the integrity of the cylinder and closed cryogenic receptacle or its service equipment may be affected;
- b) unless the cylinder and closed cryogenic receptacle and its service equipment have been examined and found to be in good working order; or
- c) unless the required certification, retest, and filling markings are legible.

4.1.1.13 Filled cylinders and closed cryogenic receptacles must not be offered for transport:

- a) when leaking;
- b) when damaged to such an extent that the integrity of the cylinder and closed cryogenic receptacle or its service equipment may be affected;
- c) unless the cylinder and closed cryogenic receptacle and its service equipment have been examined and found to be in good working order; or
- d) unless the required certification, retest, and filling markings are legible.

4.2 PACKING INSTRUCTIONS

Packing Instruction 200

For cylinders, the general packing requirements of 4;1.1 and 4;4.1.1 must be met.

Cylinders, constructed as specified in 6;5 are authorized for the transport of a specific substance when specified in the following tables (Table 1 and Table 2). Cylinders other than UN marked and certified cylinders may be used if the design, construction, testing, approval and markings conform to the requirements of the appropriate national authority in which they are approved and filled. The substances contained must be permitted in cylinders and permitted for air transport according to these Instructions. Cylinders for which prescribed periodic tests have become due must not be charged and offered for transport until such retests have been successfully completed. Valves must be suitably protected or must be designed and constructed in such a manner that they are able to withstand damage without leakage as specified in Annex B of ISO 10297:1999. Cylinders with capacities of one litre or less must be packaged in outer packaging constructed of suitable material of adequate strength and design in relation to the packaging capacity and its intended use, and secured or cushioned so as to prevent significant movement within the outer packaging during normal conditions of transport. For some substances, the special packing provisions may prohibit a particular type of cylinder. The following requirements must be met:

- 1) Pressure relief devices must be fitted on cylinders used for the transport of UN 1013 **Carbon dioxide** and UN 1070 **Nitrous oxide**. Other cylinders must be fitted with a pressure relief device if specified by the appropriate national authority of the country of use. The type of pressure relief device, the set to discharge pressure and relief capacity of pressure relief devices, if required, must be specified by the appropriate national authority of the country of use. Manifolding of cylinders is not permitted.

- 2) The following two tables cover compressed gases (Table 1) and liquefied and dissolved gases (Table 2). They provide:
- the UN number, name and description, and classification of the substance;
 - the LC₅₀ for toxic substances;
 - the types of cylinders authorized for the substance, shown by the letter "X";
 - the maximum test period for periodic inspection of the cylinders;
 - the minimum test pressure of the cylinders;
 - the maximum working pressure of the cylinders for compressed gases (where no value is given, the working pressure must not exceed two-thirds of the test pressure) or the maximum filling ratio(s) dependent on the test pressure(s) for liquefied and dissolved gases;
 - special packing provisions that are specific to a substance.

- 3) In no case must cylinders be filled in excess of the limit permitted in the following requirements:

- For compressed gases, the working pressure must be not more than two-thirds of the test pressure of the cylinders. Restrictions to this upper limit on working pressure are imposed by special packing provision "o". In no case must the internal pressure at 65°C exceed the test pressure.
- For high pressure liquefied gases, the filling ratio must be such that the settled pressure at 65°C does not exceed the test pressure of the cylinders.

The use of test pressures and filling ratios other than those in the table is permitted provided that the above criterion is met, except where special packing provision "o" applies.

For high pressure liquefied gases and gas mixtures for which relevant data are not available, the maximum filling ratio (FR) must be determined as follows:

$$FR = 8.5 \times 10^{-4} \times d_g \times P_h$$

where FR = maximum filling ratio
 d_g = gas density (at 15°C, 1 bar)(in g/l)
 P_h = minimum test pressure (in bar).

If the density of the gas is unknown, the maximum filling ratio must be determined as follows:

$$FR = \frac{P_h \times MM \times 10^{-3}}{R \times 338}$$

where FR = maximum filling ratio
 P_h = minimum test pressure (in bar)
 MM = molecular mass (in g/mol)
 $R = 8.31451 \times 10^{-2}$ bar.l/mol.K (gas constant).

For gas mixtures, the average molecular mass is to be taken, taking into account the volumetric concentrations of the various components.

- For low pressure liquefied gases, the maximum mass of contents per litre of water capacity (filling factor) must equal 0.95 times the density of the liquid phase at 50°C; in addition, the liquid phase must not fill the cylinder at any temperature up to 60°C. The test pressure of the cylinder must be at least equal to the vapour pressure (absolute) of the liquid at 65°C, minus 100 kPa (1 bar).

For low pressure liquefied gases for which filling data is not provided in the table, the maximum filling ratio must be determined as follows:

$$FR = (0.0032 \times BP - 0.24) \times d_1$$

where FR = maximum filling ratio
 BP = boiling point (in Kelvin)
 d_1 = density of the liquid at boiling point (in kg/l).

- For UN 1001, **Acetylene, dissolved**, and UN 3374 **Acetylene, solvent free**, see p).

- 4) Gas mixtures containing any of the following gases must not be offered for transport in aluminium alloy cylinders unless approved by the appropriate national authority of the State of Origin and the State of the Operator:

UN 1037 **Ethyl chloride**
 UN 1063 **Methyl chloride**
 UN 1063 **Refrigerant gas R 40**
 UN 1085 **Vinyl bromide, stabilized**
 UN 1086 **Vinyl chloride, stabilized**
 UN 1860 **Vinyl fluoride, stabilized**
 UN 1912 **Methyl chloride and methylene chloride mixture**

- 5) "Special packing provisions":

Material compatibility

- a) Aluminium alloy cylinders are forbidden.
- b) Copper valves are forbidden.
- c) Metal parts in contact with the contents must not contain more than 65 per cent copper.
- d) When steel cylinders are used, only those bearing the "H" mark in accordance with 6.5.2.7.4 p) are permitted.

Gas specific provisions:

- l) UN 1040 **Ethylene oxide** may also be packed in hermetically sealed glass ampoules or metal inner packagings suitably cushioned in fibreboard, wooden or metal boxes meeting the Packing Group I performance level. The maximum quantity permitted in any glass inner packaging is 30 g, and the maximum quantity permitted in any metal inner packaging is 200 g. After filling, each inner packaging must be determined to be leak-tight by placing the inner packaging in a hot water bath at a temperature, and for a period of time, sufficient to ensure that an internal pressure equal to the vapour pressure of ethylene oxide at 55°C is achieved. The maximum net mass in any outer packaging must not exceed 2.5 kg. When cylinders are used, they must be of the seamless or welded steel types that are equipped with suitable pressure relief devices. Each cylinder must be tested for leakage with an inert gas before each refilling and must be insulated with three coats of heat retardant paint or in any equally efficient manner. The maximum net quantity per cylinder must not exceed 25 kg.
- m) Cylinders must be filled to a working pressure not exceeding 5 bar.
- o) In no case must the working pressure or filling ratio shown in the table be exceeded.
- p) For UN 1001 **Acetylene, dissolved**, and UN 3374 **Acetylene, solvent free**: cylinders must be filled with a homogeneous monolithic porous mass; the working pressure and the quantity of acetylene must not exceed the values prescribed in the approval or in ISO 3807-1:2000 or ISO 3807-2:2000, as applicable.

For UN 1001 **Acetylene, dissolved**, cylinders must contain a quantity of acetone or suitable solvent as specified in the approval (see ISO 3807-1:2000 or ISO 3807-2:2000, as applicable); cylinders fitted with pressure relief devices must be transported vertically.

The test pressure of 52 bar applies only to cylinders conforming to ISO 3807-2:2000.

- ra) Ethyl chloride may be carried in securely sealed glass ampoules (IP.8) containing not more than 5 g of ethyl chloride with a ullage of not less than 7.5 per cent at 21°C. Ampoules must be cushioned with efficient non-combustible material in partitioned cartons with not more than 12 ampoules per carton. The cartons must be tightly packed to prevent movement in wooden boxes (4C1, 4C2), plywood boxes (4D), reconstituted wood boxes (4F), fibreboard boxes (4G) or plastic boxes (4H1, 4H2) that meet the performance testing requirements of 6.4 at the Packing Group II performance level. Not more than 300 g of ethyl chloride is permitted per package.
- s) Aluminium alloy cylinders must be:
 - Equipped only with brass or stainless steel valves; and
 - Cleaned in accordance with ISO 11621:1997 and not contaminated with oil.

Periodic inspection:

- u) The interval between periodic tests may be extended to 10 years for aluminium alloy cylinders when the alloy of the cylinder has been subjected to stress corrosion testing as specified in ISO 7866:1999.
- v) The interval between periodic inspections for steel cylinders may be extended to 15 years if approved by the appropriate national authority of the country of use.

Requirements for N.O.S. descriptions and for mixtures:

- z) The construction materials of the cylinders and their accessories must be compatible with the contents and must not react to form harmful or dangerous compounds therewith.

The test pressure and filling ratio must be calculated in accordance with the relevant requirements of PI 200.

The necessary steps must be taken to prevent dangerous reactions (i.e. polymerization or decomposition) during transport. If necessary, stabilization or addition of an inhibitor may be required.

Note. — For the carriage of oxygen to provide life support to aquatic animals, see Note 7 of the Introductory Notes to this Part.

Table 1. COMPRESSED GASES

UN No.	Name and description	Class or Division	Subsidiary risk	LC ₅₀ ml/m ³	Cylinders	Test period, years	Test pressure, bar*	Maximum working pressure, bar*	Special packing provisions*
1002	Air, compressed	2.2			X	10			
1006	Argon, compressed	2.2			X	10			
1046	Helium, compressed	2.2			X	10			
1049	Hydrogen, compressed	2.1			X	10			d
1056	Krypton, compressed	2.2			X	10			
1065	Neon, compressed	2.2			X	10			
1066	Nitrogen, compressed	2.2			X	10			
1071	Oil gas, compressed	2.3	2.1		X	5			
1072	Oxygen, compressed	2.2	5.1		X	10			s
1954	Compressed gas, flammable, n.o.s.	2.1			X	10			z
1956	Compressed gas, n.o.s.	2.2			X	10			z
1957	Deuterium, compressed	2.1			X	10			d
1964	Hydrocarbon gas mixture, compressed, n.o.s.	2.1			X	10			z
1971	Methane, compressed or natural gas, compressed with high methane content	2.1			X	10			
2034	Hydrogen and methane mixture, compressed	2.1			X	10			
3156	Compressed gas, oxidizing, n.o.s.	2.2	5.1		X	10			z

* Where the entries are blank, the working pressure must not exceed two-thirds of the test pressure.

Table 2. LIQUEFIED GASES AND DISSOLVED GASES

UN No.	Name and description	Class or Division	Subsidiary risk	LC ₅₀ ml/m ³	Cylinders	Test period, years	Test pressure, bar	Filling ratio	Special packing provisions
1001	Acetylene, dissolved	2.1			X	10	60 52		c, p
1009	Bromotrifluoromethane (refrigerant gas R 13b1)	2.2			X	10	42 120 250	1.13 1.44 1.60	
1010	Butadienes, stabilized (1,2-butadiene)	2.1			X	10	10	0.59	
1010	Butadienes, stabilized (1,3-butadiene)	2.1			X	10	10	0.55	z

UN No.	Name and description	Class or Division	Subsidiary risk	LC ₅₀ ml/m ³	Cylinders	Test period, years	Test pressure, bar	Filling ratio	Special packing provisions
1010	Butadienes and hydrocarbon mixture, stabilized containing more than 40% butadienes	2.1			X	10			v z
1011	Butane	2.1			X	10	10	0.52	v
1012	Butylene (butylenes mixture)	2.1			X	10	10	0.50	z
1012	Butylene (1-butylene)	2.1			X	10	10	0.53	
1012	Butylene (cis-2-butylene)	2.1			X	10	10	0.55	
1012	Butylene (trans-2 butylene)	2.1			X	10	10	0.54	
1013	Carbon dioxide	2.2			X	10	190 250	0.68 0.76	
1018	Chlorodifluoromethane (refrigerant gas R 22)	2.2			X	10	27	1.03	
1020	Chloropentafluoroethane (refrigerant gas R 115)	2.2			X	10	25	1.05	
1021	1-Chloro-1,2,2,2-tetrafluoroethane (refrigerant gas R 124)	2.2			X	10	11	1.20	
1022	Chlorotrifluoromethane (refrigerant gas R 13)	2.2			X	10	100 120 190 250	0.83 0.90 1.04 1.11	
1027	Cyclopropane	2.1			X	10	18	0.55	
1028	Dichlorodifluoromethane (refrigerant gas R 12)	2.2			X	10	16	1.15	
1029	Dichlorofluoromethane (refrigerant gas R 21)	2.2			X	10	10	1.23	
1030	1,1-Difluoroethane (Refrigerant gas R 152 a)	2.1			X	10	16	0.79	
1032	Dimethylamine, anhydrous	2.1			X	10	10	0.59	b
1033	Dimethyl ether	2.1			X	10	18	0.58	
1035	Ethane	2.1			X	10	95 120 300	0.25 0.30 0.40	
1036	Ethylamine	2.1			X	10	10	0.61	b
1037	Ethyl chloride	2.1			X	10	10	0.80	a, ra
1039	Ethyl methyl ether	2.1			X	10	10	0.64	
1041	Ethylene oxide and carbon dioxide mixture with more than 9% ethylene oxide but not more than 87%	2.1			X	10	190 250	0.66 .75	
1043	Fertilizer ammoniating solution with free ammonia	2.2			X	5			b, z
1055	Isobutylene	2.1			X	10	10	0.52	
1058	Liquefied gases, non-flammable, charged with nitrogen, carbon dioxide or air	2.2			X	10			
1060	Methylacetylene and propadiene mixture, stabilized	2.1			X	10			c, z

#

UN No.	Name and description	Class or Division	Subsidiary risk	LC ₅₀ ml/m ³	Cylinders	Test period, years	Test pressure, bar	Filling ratio	Special packing provisions
1060	Methylacetylene and propadiene mixture, stabilized (propadiene with 1% to 4% methylacetylene)	2.1			X	10	22	0.52	c
1061	Methylamine, anhydrous	2.1			X	10	13	0.58	b
1063	Methyl chloride (refrigerant gas R 40)	2.1			X	10	17	0.81	a
1070	Nitrous oxide	2.2	5.1		X	10	180 225 250	0.68 0.74 0.75	
1075	Petroleum gases, liquefied	2.1			X	10			v, z
1077	Propylene	2.1			X	10	27	0.43	
1078	Refrigerant gas, n.o.s.	2.2			X	10			z
1080	Sulphur hexafluoride	2.2			X	10	70 140 160	1.06 1.34 1.38	
1081	Tetrafluoroethylene, stabilized	2.1			X	10	200		m, o
1083	Trimethylamine, anhydrous	2.1			X	10	10	0.56	b
1085	Vinyl bromide, stabilized	2.1			X	10	10	1.37	a
1086	Vinyl chloride, stabilized	2.1			X	10	12	0.81	a
1087	Vinyl methyl ether, stabilized	2.1			X	10	10	0.67	
1858	Hexafluoropropylene (refrigerant gas R 1216)	2.2			X	10	22	1.11	
1860	Vinyl fluoride, stabilized	2.1			X	10	250	0.64	a
1912	Methyl chloride and methylene chloride mixture	2.1			X	10	17	0.81	a
1952	Ethylene oxide and carbon dioxide mixture with not more than 9% ethylene oxide	2.2			X	10	190 250	0.66 0.75	
1958	1,2-dichloro-1,1,2,2-tetrafluoroethane (refrigerant gas R 114)	2.2			X	10	10	1.30	
1959	1,1-difluoroethylene (refrigerant gas R 1132a)	2.1			X	10	250	0.77	
1962	Ethylene	2.1			X	10	225 300	0.34 0.38	
1965	Hydrocarbon gas mixture, liquefied, n.o.s.	2.1			X	10			v, z
1968	Insecticide gas, n.o.s.	2.2			X	10			z
1969	Isobutane	2.1			X	10	10	0.49	v
1973	Chlorodifluoromethane and chloropentafluoroethane mixture with fixed boiling point, with approximately 49% chlorodifluoromethane (refrigerant gas R 502)	2.2			X	10	31	1.01	
1974	Chlorodifluorobromomethane (refrigerant gas R 12b1)	2.2			X	10	10	1.61	

UN No.	Name and description	Class or Division	Subsidiary risk	LC ₅₀ ml/m ³	Cylinders	Test period, years	Test pressure, bar	Filling ratio	Special packing provisions
1976	Octafluorocyclobutane (refrigerant gas R C318)	2.2			X	10	11	1.32	
1978	Propane	2.1			X	10	23	0.43	v
1982	Tetrafluoromethane (refrigerant gas R 14)	2.2			X	10	200 300	0.71 0.90	
1983	1-chloro-2,2,2-trifluoroethane (refrigerant gas R 133a)	2.2			X	10	10	1.18	
1984	Trifluoromethane (refrigerant gas R 23)	2.2			X	10	190 250	0.88 0.96	
2035	1,1,1-trifluoroethane (refrigerant gas R 143a)	2.1			X	10	35	0.73	
2036	Xenon	2.2			X	10	130	1.28	
2044	2,2-dimethylpropane	2.1			X	10	10	0.53	
2073	Ammonia solution, relative density less than 0.880 at 15°C in water, with more than 35% but not more than 40% ammonia with more than 40% but not more than 50% ammonia	2.2			X X	5 5	10 12	0.80 0.77	b b
2193	Hexafluoroethane (refrigerant gas R 116)	2.2			X	10	200	1.13	
2200	Propadiene, stabilized	2.1			X	10	22	0.50	
2419	Bromotrifluoroethylene	2.1			X	10	10	1.19	
2422	Octafluorobut-2-ene (refrigerant gas R 1318)	2.2			X	10	12	1.34	
2424	Octafluoropropane (refrigerant gas R 218)	2.2			X	10	25	1.04	
2451	Nitrogen trifluoride	2.2	5.1		X	10	200	0.50	
2452	Ethylacetylene, stabilized	2.1			X	10	10	0.57	c
2453	Ethyl fluoride (refrigerant gas R 161)	2.1			X	10	30	0.57	
2454	Methyl fluoride (refrigerant gas R 41)	2.1			X	10	300	0.63	
2517	1-chloro-1,1-difluoroethane (refrigerant gas R 142b)	2.1			X	10	10	0.99	
2599	Chlorotrifluoromethane and trifluoromethane azeotropic mixture with approximately 60% chlorotrifluoromethane (refrigerant gas R 503)	2.2			X	10	31 42 100	0.12 0.17 0.64	
2601	Cyclobutane	2.1			X	10	10	0.63	
2602	Dichlorodifluoro-methane and difluoroethane azeotropic mixture with approximately 74% dichlorodifluoromethane (refrigerant gas R 500)	2.2			X	10	22	1.01	
3070	Ethylene oxide and dichlorodifluoro-methane mixture with not more than 12.5% ethylene oxide	2.2			X	10	18	1.09	

UN No.	Name and description	Class or Division	Subsidiary risk	LC ₅₀ ml/m ³	Cylinders	Test period, years	Test pressure, bar	Filling ratio	Special packing provisions
3153	Perfluoro(methyl vinyl ether)	2.1			X	10	20	0.75	
3154	Perfluoro(ethyl vinyl ether)	2.1			X	10	10	0.98	
3157	Liquefied gas, oxidizing, n.o.s.	2.2	5.1		X	10			z
3159	1,1,1,2-tetrafluoroethane (refrigerant gas R 134a)	2.2			X	10	18	1.05	
3161	Liquefied gas, flammable, n.o.s.	2.1			X	10			z
3163	Liquefied gas, n.o.s.	2.2			X	10			z
3220	Pentafluoroethane (refrigerant gas R 125)	2.2			X	10	49 35	0.95 0.87	
3252	Difluoromethane (refrigerant gas R 32)	2.1			X	10	48	0.78	
3296	Heptafluoropropane (refrigerant gas R 227)	2.2			X	10	13	1.21	
3297	Ethylene oxide and chlorotetrafluoroethane mixture with not more than 8.8% ethylene oxide	2.2			X	10	10	1.16	
3298	Ethylene oxide and pentafluoroethane mixture with not more than 7.9% ethylene oxide	2.2			X	10	26	1.02	
3299	Ethylene oxide and tetrafluoroethane mixture with not more than 5.6% ethylene oxide	2.2			X	10	17	1.03	
3337	Refrigerant gas R 404a	2.2			X	10	36	0.82	
3338	Refrigerant gas R 407a	2.2			X	10	32	0.94	
3339	Refrigerant gas R 407b	2.2			X	10	33	0.93	
3340	Refrigerant gas R 407c	2.2			X	10	30	0.95	
3354	Insecticide gas, flammable, n.o.s.	2.1			X	10			z
3374	Acetylene, solvent free	2.1			X	5	60 52		c, p

Packing Instruction 201

The general packing requirements of 4;1 must be met.

Hydrocarbon gas-powered small devices, including replacement cartridges, and lighters for cigarettes and lighter refills must comply with the requirements of the country in which they are filled. They must be provided with protection against inadvertent discharge. Lighters must not contain more than 10 g of liquefied petroleum gas. Hydrocarbon gas-powered small devices and lighter refills must not contain more than 65 g of liquefied petroleum gas. The liquid portion of the gas must not exceed 85 per cent of the capacity of the fuel vessel at 15°C. The articles, including closures, must be capable of withstanding an internal pressure of twice the pressure in the fuel vessel at 55°C. Where refill cartridges are in the form of aerosol dispensers, the pressure in the aerosol must not exceed 1 500 kPa at 55°C and the requirements of subparagraphs b) to e) of Packing Instruction 203 must be met. The articles must be tightly packed to prevent inadvertent operation in wooden boxes (4C1, 4C2), plywood boxes (4D), reconstituted wood boxes (4F), fibreboard boxes (4G) or plastic boxes (4H1, 4H2) of Packing Group II. The net quantity of liquefied petroleum gas in each package must not exceed 1 kg on passenger aircraft and 15 kg on cargo aircraft. Articles which meet the above requirements are permitted only when the valve and ignition mechanisms are designed or securely sealed, taped or otherwise fastened to prevent operation or leakage of contents during transport.

Articles permitted under this packing instruction may also include, within the same outer packaging, replacement cartridges exceeding 65 g each, containing liquefied petroleum gas, provided such cartridges comply with all the requirements of Packing Instruction 200, they are not manifolded or connected to the article and they cannot cause the failure or functioning of the article during transport. Such consignments must be carried on cargo aircraft.

Packing Instruction 202

This instruction applies to Class 2 refrigerated liquefied gases in open and closed cryogenic receptacles.

Requirements for closed cryogenic receptacles

- 1) The general requirements of 4;1 and 4;4.1 must be met.
- 2) The requirements of 6;5 must be met.
- 3) The closed cryogenic receptacles must be so insulated that they do not become coated with frost.
- 4) Test pressure

Refrigerated liquids must be filled in closed cryogenic receptacles with the following minimum test pressures:

- a) For closed cryogenic receptacles with vacuum insulation, the test pressure must not be less than 1.3 times the sum of the maximum internal pressure of the filled receptacle, including during filling and discharge, plus 100 kPa (1 bar);
 - b) For other closed cryogenic receptacles, the test pressure must be not less than 1.3 times the maximum internal pressure of the filled receptacle, taking into account the pressure developed during filling and discharge.
- 5) Degree of filling

For non-flammable, non-toxic refrigerated liquefied gases, the volume of liquid phase at the filling temperature and at a pressure of 100 kPa (1 bar) must not exceed 98 per cent of the water capacity of the pressure receptacle.

- 6) Pressure-relief devices

Every closed cryogenic receptacle, having a nominal capacity in excess of 550 L, must be provided with at least 2 pressure-relief devices. The pressure-relief device must be of the type that will resist dynamic forces including surge.

Closed cryogenic receptacles, having a nominal capacity of 550 L or less, must be provided with at least 1 pressure-relief device, and may in addition have a frangible disc in parallel with the spring loaded device in order to meet the requirements of 6;5.1.3.6.5. The pressure-relief device must be of the type that will resist dynamic forces including surge.

Note.— The pressure-relief devices must meet the requirements of 6;5.1.3.6.4 and 6;5.1.3.6.5.

7) Compatibility

Materials used to ensure the leakproofness of the joints or for the maintenance of the closures must be compatible with the contents. In the case of receptacles intended for the transport of oxidizing gases (i.e. with a subsidiary risk of 5.1), these materials must not react with these gases in a dangerous manner.

8) Periodic inspection

The periodic inspection and test frequencies of pressure relief valves must not exceed five years.

Note.— Insulated packagings containing refrigerated liquid nitrogen fully absorbed in a porous material are not subject to these Instructions when carried as cargo provided they meet the requirements of Special Provision A152.

Requirements for open cryogenic receptacles

Open cryogenic receptacles must be constructed to meet the following requirements:

1. The receptacles must be designed, manufactured, tested and equipped in such a way as to withstand all conditions, including fatigue, to which they will be subjected during their normal use and during normal conditions of transport.
2. The maximum water capacity for metal receptacles is 50 litres and for glass receptacles it is 5 litres.
3. The receptacle must have a double wall construction with the space between the inner and outer wall being evacuated (vacuum insulation). The insulation must prevent the formation of hoar frost on the exterior of the receptacle.
4. The materials of construction must have suitable mechanical properties at the service temperature.
5. Materials which are in direct contact with the dangerous goods must not be affected or weakened by the dangerous goods intended to be transported and must not cause a dangerous effect, e.g. catalysing a reaction or reacting with the dangerous goods.
6. Receptacles of glass double wall construction must have an outer packaging with suitable cushioning or absorbent materials which can withstand the pressures and impacts liable to occur under normal conditions of transport.
7. The receptacle must be designed to remain in an upright position during transport (e.g. have a base whose smaller horizontal dimension is greater than the height of the centre of gravity when filled to capacity or be mounted on gimbals).
8. Receptacles must be metal or glass vacuum insulated vessels or flasks vented to the atmosphere to prevent any increase in pressure within the package and the openings must be fitted with devices allowing gases to escape, preventing any splashing out of liquid and so configured that they remain in place during transport.
9. Open cryogenic receptacles must bear the following marks permanently affixed, e.g. by stamping, engraving or etching:
 - the manufacturer's name and address;
 - the model number or name;
 - the serial or batch number;
 - the UN number and proper shipping name of gases for which the receptacle is intended;
 - the capacity of the receptacle in litres.

Note.— The size of the marking must be as set out for cylinders in Part 6;5.2.7.1. Open cryogenic receptacles manufactured prior to 1 January 2012 are not required to be so marked.

10. Open cryogenic receptacles are permitted for nitrogen, argon, krypton, neon and xenon refrigerated liquids.

Packing Instruction 203

Passenger and cargo aircraft for UN 1950 and 2037 only

The general packing requirements of 4;1 must be met.

For the purposes of this packing instruction, a receptacle is considered to be an inner packaging.

Note.— “Receptacle” has the same meaning as set out in 1;3. Any reference in this packing instruction to receptacle will include “aerosols” of UN 1950 and “receptacles, small, containing gas” and “gas cartridges” of UN 2037.

Metal aerosols (IP.7, IP.7A, IP.7B) and non-refillable receptacles containing gas (gas cartridges)

Non-refillable metal aerosols and non-refillable receptacles containing gas (gas cartridges) must not exceed 1 000 mL capacity.

The following conditions must be met:

- a) the pressure in the receptacle must not exceed 1 500 kPa at 55°C and each receptacle must be capable of withstanding without bursting a pressure of at least 1.5 times the equilibrium pressure of the contents at 55°C;
- b) if the pressure in the receptacle exceeds 970 kPa at 55°C but does not exceed 1 105 kPa at 55°C, an IP.7, IP.7A or IP.7B metal receptacle must be used;
- c) if the pressure in the receptacle exceeds 1 105 kPa at 55°C but does not exceed 1 245 kPa at 55°C, an IP.7A or IP.7B metal receptacle must be used;
- d) if the pressure in the receptacle exceeds 1 245 kPa at 55°C, an IP.7B metal receptacle must be used;
- e) IP.7B metal receptacles having a minimum burst pressure of 1 800 kPa may be equipped with an inner capsule charged with a non-flammable, non-toxic compressed gas to provide the propellant function. In this case, the pressures indicated in a), b), c) or d) do not apply to the pressure within the capsule for an aerosol. The quantity of gas contained in the capsule must be so limited such that the minimum burst pressure of the receptacle would not be exceeded if the entire gas content of the capsule were released into the outer metal receptacle;
- f) the liquid content must not completely fill the closed receptacle at 55°C;
- g) each receptacle exceeding 120 mL capacity must have been heated until the pressure in the receptacle is equivalent to the equilibrium pressure of the contents at 55°C, without evidence of leakage, distortion or other defect.

Plastic aerosols (IP.7C)

Non-refillable plastic aerosols must not exceed 120 mL capacity, except when the propellant is a non-flammable, non-toxic gas and the contents are not dangerous goods in accordance with the provisions of the Technical Instructions, in which case the quantity must not exceed 500 mL.

The following conditions must be met:

- a) the contents must not completely fill the closed receptacle at 55°C;
- b) the pressure in the receptacle may not exceed 970 kPa at 55°C; and
- c) each receptacle must be leak tested in accordance with the provisions of 6;3.2.8.1.6.

+

ADDITIONAL PACKING REQUIREMENTS

- Packagings must meet Packing Group II performance requirements.
- Release valves on aerosols must be protected by a cap or other suitable means to prevent inadvertent release of the contents during normal conditions of air transport.
- Receptacles must be tightly packed, so as to prevent movement.

+

OUTER PACKAGINGS (see 6;3.1)*Boxes*

Aluminium (4B)
Fibreboard (4G)
Natural wood (4C1, 4C2)
Other metal (4N)
Plastics (4H1, 4H2)
Plywood (4D)
Reconstituted wood (4F)
Steel (4A)

Drums

Aluminium (1B2)
Fibre (1G)
Other metal (1N2)
Plastics (1H2)
Plywood (1D)
Steel (1A2)

Packing Instruction Y203

Passenger and cargo aircraft for UN 1950 and 2037 only

The requirements of 3.4 must be met.

For the purposes of this packing instruction, a receptacle is considered to be an inner packaging.

Note.— "Receptacle" has the same meaning as set out in 1.3. Any reference in this packing instruction to receptacle will include "aerosols" of UN 1950 and "receptacles, small, containing gas" and "gas cartridges" of UN 2037.

Metal aerosols (IP.7, IP.7A, IP.7B) and non-refillable receptacles containing gas (gas cartridges)

Non-refillable metal aerosols and non-refillable receptacles containing gas (gas cartridges) containing toxic substances must not exceed 120 mL capacity.

All other non-refillable metal aerosols and non-refillable receptacles containing gas (gas cartridges) must not exceed 1 000 mL capacity.

The following conditions must be met:

- a) the pressure in the receptacle must not exceed 1 500 kPa at 55°C and each receptacle must be capable of withstanding without bursting a pressure of at least 1.5 times the equilibrium pressure of the contents at 55°C;
- b) if the pressure in the receptacle exceeds 970 kPa at 55°C but does not exceed 1 105 kPa at 55°C, an IP.7, IP.7A or IP.7B metal receptacle must be used;
- c) if the pressure in the receptacle exceeds 1 105 kPa at 55°C, an IP.7A or IP.7B metal receptacle must be used;
- d) if the pressure in the receptacle exceeds 1 245 kPa at 55°C, an IP.7B metal receptacle must be used;
- e) IP.7B metal receptacles having a minimum burst pressure of 1 800 kPa may be equipped with an inner capsule charged with a non-flammable, non-toxic compressed gas to provide the propellant function. In this case, the pressures indicated in a), b), c) or d) do not apply to the pressure within the capsule for an aerosol. The quantity of gas contained in the capsule must be so limited such that the minimum burst pressure of the receptacle would not be exceeded if the entire gas content of the capsule were released into the outer metal receptacle;
- f) the liquid content must not completely fill the closed receptacle at 55°C;
- g) each receptacle exceeding 120 mL capacity must have been heated until the pressure in the receptacle is equivalent to the equilibrium pressure of the contents at 55°C, without evidence of leakage, distortion or other defect.

Plastic aerosols (IP.7C)

Non-refillable plastic aerosols must not exceed 120 mL capacity, except when the propellant is a non-flammable, non-toxic gas and the contents are not dangerous goods in accordance with the provisions of the Technical Instructions, in which case the quantity must not exceed 500 mL.

The following conditions must be met:

- a) the contents must not completely fill the closed receptacle at 55°C;
- b) the pressure in the receptacle may not exceed 970 kPa at 55°C; and
- c) each receptacle must be leak tested in accordance with the provisions of 6.3.2.8.1.6.

+	ADDITIONAL PACKING REQUIREMENTS	
	<ul style="list-style-type: none"> — Release valves on aerosols must be protected by a cap or other suitable means to prevent inadvertent release of the contents during normal conditions of air transport. — Receptacles must be tightly packed, so as to prevent movement. 	
+	OUTER PACKAGINGS (see 6;3.1)	
	<i>Boxes</i>	<i>Drums</i>
	Aluminium	Aluminium
	Fibreboard	Fibre
	Natural wood	Other metal
	Other metal	Plastics
	Plastics	Plywood
	Plywood	Steel
	Reconstituted wood	
	Steel	

Packing Instruction 204

The general packing requirements of 4;1 must be met.

Aerosols, non-flammable, containing biological products or a medical preparation which will be deteriorated by a heat test, are acceptable in inner non-refillable receptacles not exceeding 575 mL capacity each, providing all the following conditions are met:

- a) the pressure in the aerosol must not exceed 970 kPa at 55°C;
- b) the liquid contents must not completely fill the closed receptacle at 55°C;
- c) one aerosol out of each lot of 500 or less must be heated until the pressure in the aerosol is equivalent to the equilibrium pressure of the contents at 55°C, without evidence of leakage, distortion or other defect;
- d) the valves must be protected by a cap or other suitable means during transport;
- e) aerosols must be tightly packed, so as to prevent movement, in wooden boxes (4C1, 4C2), plywood boxes (4D), reconstituted wood boxes (4F), fibreboard boxes (4G) or plastic boxes (4H1, 4H2) of Packing Group II.

Packing Instruction Y204

The requirements of 3;4 must be met.

Single packagings are not permitted.

COMBINATION PACKAGINGS:

INNER:

Aerosols, non-flammable, containing only a non-toxic substance or substances and biological products or a medical preparation which will be deteriorated by a heat test, are acceptable in inner non-refillable receptacles not exceeding 575 mL capacity each, providing all the following conditions are met:

- a) the pressure in the aerosol must not exceed 970 kPa at 55°C;
- b) the liquid contents must not completely fill the closed receptacle at 55°C;
- c) one aerosol out of each lot of 500 or less must be heated until the pressure in the aerosol is equivalent to the equilibrium pressure of the contents at 55°C, without evidence of leakage, distortion or other defect;
- d) the valves must be protected by a cap or other suitable means during transport;
- e) aerosols must be tightly packed, so as to prevent movement, in one of the following boxes:

OUTER:

Boxes

Fibreboard
Plastics
Plywood
Reconstituted wood
Wooden

Packing Instruction 206

Passenger and cargo aircraft for UN 3167, UN 3168 and UN 3169 only

General requirements

Part 4, Chapter 1 requirements must be met, including:

A gas sample may only be accepted for transport as a non-pressurized gas providing it is at a pressure corresponding to ambient atmospheric pressure at the time the containment system is closed and this must not exceed 105 kPa absolute.

Cylinders and gas receptacles conforming to the construction, testing and filling requirements approved by the appropriate national authority are permitted.

1) Compatibility requirements

- Substances must be compatible with their packagings as required by 4;1.1.3.

2) Closure requirements

- Closures must meet the requirements of 4;1.1.4.

COMBINATION PACKAGINGS						SINGLE PACKAGINGS
<i>UN number and proper shipping name</i>	<i>Inner packaging (see 6;3.2)</i>	<i>Inner packaging quantity (per receptacle) — passenger</i>	<i>Total quantity per package — passenger</i>	<i>Inner packaging quantity (per receptacle) — cargo</i>	<i>Total quantity per package — cargo</i>	
UN 3167 Gas sample, non-pressurized, flammable, n.o.s.	Glass	1.0 L	1.0 L	2.5 L	5.0 L	No
	Metal	1.0 L		2.5 L		
UN 3168 Gas sample, non-pressurized, toxic, flammable, n.o.s.	Glass	Forbidden	Forbidden	1.0 L	1.0 L	No
	Metal			1.0 L		
UN 3169 Gas sample, non-pressurized, toxic, n.o.s.	Glass	Forbidden	Forbidden	1.0 L	1.0 L	No
	Metal			1.0 L		

ADDITIONAL PACKING REQUIREMENTS FOR COMBINATION PACKAGINGS

- Inner packagings must be hermetically sealed.
- Packagings must meet the Packing Group II performance requirements.
- Inner packaging(s) must be packed so as to prevent movement in the outer packaging.

OUTER PACKAGINGS OF COMBINATION PACKAGINGS (see 6;3.1)

Boxes

Aluminium (4B)
Fibreboard (4G)
Natural wood (4C1, 4C2)
Other metal (4N)
Plastics (4H1, 4H2)
Plywood (4D)
Reconstituted wood (4F)
Steel (4A)

Drums

Aluminium (1B1, 1B2)
Fibre (1G)
Other metal (1N1, 1N2)
Plastics (1H1, 1H2)
Steel (1A1, 1A2)

Jerricans

Aluminium (3B1, 3B2)
Plastics (3H1, 3H2)
Steel (3A1, 3A2)

Packing Instruction 208

The general packing requirements of 4;1 must be met.

Articles, pressurized pneumatic or hydraulic containing a non-flammable, non-liquefied and non-toxic gas and constructed from materials which will not fragment under pressure, may be carried under the following conditions:

- a) when installed in construction equipment and assembled machinery, articles must be designed and constructed with a burst pressure of not less than 5 times their charged pressure at 21°C when shipped;

Note.— Labelling, marking, dangerous goods transport document and information to pilot-in-command are not required.

- b) when tightly packed to prevent movement in strong outer packagings and charged to not more than 1 380 kPa at 21°C, the following conditions also apply:

- 1) each article must have a fluid space not exceeding 41 L under stored pressure;
- 2) each article must be tested without failure or damage to at least 3 times its charged pressure at 21°C but not less than 830 kPa before initial shipment and before each refilling and re-shipment;

- c) when tightly packed to prevent movement in strong outer packagings and charged with a pressure exceeding 1 380 kPa at 21°C the following conditions also apply:

- 1) each article must have a fluid space not exceeding 41 L under stored pressure;
- 2) each article must be tested without failure or damage to at least 3 times its charged pressure at 21°C, but not less than 830 kPa before initial shipment and before each refilling and re-shipment;
- 3) each article must be designed and constructed with a burst pressure of not less than 5 times its charged pressure at 21°C when shipped.

Packing Instruction 211

The general packing requirements of 4;1 must be met.

Refrigerating machines or components containing non-toxic liquefied gases or Ammonia solutions (UN 2672) must meet the following requirements:

- a) each cylinder must not contain more than 450 kg of a Division 2.2 gas without subsidiary risk or 25 kg of Ammonia solutions (UN 2672);
- b) machines or components having two or more charged cylinders may not contain an aggregate of more than 910 kg of a Division 2.2 gas without subsidiary risk or more than 45 kg of Ammonia solutions (UN 2672);
- c) each cylinder must be equipped with a safety device meeting the requirements of a recognized national standard;
- d) each cylinder must be equipped with a shut-off valve at each opening except openings used for safety devices and with no other connection. These valves must be closed prior to and during transport;
- e) cylinders must be manufactured, inspected and tested in accordance with a recognized UN or national standard;
- f) all parts subject to refrigerant pressure during shipment must be tested in accordance with a recognized UN or national standard;
- g) the liquid portion of the refrigerant, if any, must not completely fill any pressure vessel at 55°C;
- h) the amount of refrigerant, if liquefied, must not exceed the filling density prescribed by applicable State regulations.

Packing Instruction 212

The general packing requirements of 4;1 must be met.

Aerosols, non-flammable, which are tear gas devices are permitted in inner non-refillable metal receptacles not exceeding 1 000 mL capacity each providing all the following conditions are met:

- a) the pressure in the aerosol must not exceed 1 500 kPa at 55°C and each receptacle must be capable of withstanding without bursting a pressure of at least 1.5 times the equilibrium pressure of the contents at 55°C;
- b) if the pressure in the aerosol does not exceed 1 105 kPa at 55°C, an IP.7, IP.7A or IP.7B metal receptacle must be used;
- c) if the pressure in the aerosol exceeds 1 105 kPa at 55°C but does not exceed 1 245 kPa at 55°C, an IP.7A or IP.7B metal receptacle must be used;
- d) if the pressure in the aerosol exceeds 1 245 kPa at 55°C, an IP.7B metal receptacle must be used;
- e) IP.7B metal receptacles having a minimum burst pressure of 1 800 kPa may be equipped with an inner capsule charged with a non-flammable, non-toxic compressed gas to provide the propellant function. In this case, the pressures indicated in a), b), c) or d) do not apply to the pressure within the capsule. The quantity of gas contained in the capsule must be so limited such that the minimum burst pressure of the receptacle would not be exceeded if the entire gas content of the capsule were released into an aerosol;
- f) the liquid content must not completely fill the closed receptacle at 55°C;
- g) each aerosol must have been heated until the pressure in the aerosol is equivalent to the equilibrium pressure of the contents at 55°C, without evidence of leakage, distortion or other defect;
- h) the valves must be protected by a cap or other suitable means during transport;
- i) aerosols must be individually placed into spiral wound tubes fitted with metal ends or a double-faced fibreboard box with suitable padding, which must be tightly packed in wooden boxes (4C1, 4C2), plywood boxes (4D), reconstituted wood boxes (4F), fibreboard boxes (4G) or plastic boxes (4H1, 4H2) of Packing Group II. Maximum net quantity per package is 50 kg.

Packing Instruction 213

The general packing requirements of 4;1 must be met.

Fire extinguishers with compressed or liquefied gas must be packed in strong outer packagings so that they cannot be accidentally activated.

Fire extinguishers may include installed actuating cartridges (cartridges, power device of Division 1.4C or 1.4S), without changing the classification of Division 2.2, provided the total quantity of deflagrating (propellant) explosives does not exceed 3.2 g per extinguishing unit.

- + Large fire extinguishers may also be transported unpackaged provided that the requirements of S-4;3.1.2 a) to e) are met, the valves are protected by one of the methods in accordance with 4;4.1.1.8 a) to c) and other equipment mounted on the fire extinguisher is protected to prevent accidental activation. For the purpose of this packing instruction, "large fire extinguishers" means fire extinguishers as described in sub-paragraphs c) to e) of Special Provision A19.

Packing Instruction 214

Cargo aircraft only for UN 3468 only

This Instruction applies to storage systems containing hydrogen absorbed in a metal hydride (UN 3468) individually or when contained in equipment and apparatus when transported on cargo aircraft.

- 1) For metal hydride storage systems, the general packing requirements of 4;4.1 must be met.
- 2) Only cylinders not exceeding 150 L in water capacity and having a maximum developed pressure not exceeding 25 MPa are covered by this packing instruction.
- 3) Metal hydride storage systems meeting the applicable requirements of 6;5 for the construction and testing of cylinders containing gas may be used for the transport of hydrogen only.
- 4) When steel cylinders or composite cylinders with steel liners are used, only those bearing the "H" mark, in accordance with 6;5.2.9.2 j) are permitted.
- 5) Metal hydride storage systems must meet the service conditions, design criteria, rated capacity, type tests, batch tests, routine tests, test pressure, rated charging pressure and provisions for pressure relief devices for transportable metal hydride storage systems specified in ISO 16111:2008, and their conformity and approval must be assessed in accordance with 6;5.2.5.
- 6) Metal hydride storage systems must be filled with hydrogen at a pressure not exceeding the rated charging pressure shown in the permanent markings on the system as specified in ISO 16111:2008.
- 7) The periodic test requirements for a metal hydride storage system must be in accordance with ISO 16111:2008 and carried out in accordance with 6;5.2.6, and the interval between periodic inspections must not exceed five years.
- 8) Storage systems with a water capacity of less than 1 L must be packaged in rigid outer packagings constructed of suitable material of adequate strength and design in relation to the packaging capacity and its intended use. They must be adequately secured or cushioned so as to prevent damage during normal conditions of transport.
- 9) Maximum net quantity per package for cargo aircraft is 100 kg of metal hydride storage systems, including when such storage systems are packed with equipment or contained in equipment.

Packing Instruction 215

Passenger and cargo aircraft for UN 3478 and 3479 only

General requirements

Part 4;1.1.1, 1.1.2 and 1.1.8 requirements must be met, including:

1) Compatibility requirements

- Substances must be compatible with their packagings as required by 4;1.1.3.

<i>UN number and name</i>	<i>Quantity — passenger</i>	<i>Quantity — cargo</i>
UN 3478 Fuel cell cartridges containing liquefied flammable gas	1 kg of fuel cell cartridges	15 kg of fuel cell cartridges
UN 3479 Fuel cell cartridges containing hydrogen in metal hydride		

ADDITIONAL PACKING REQUIREMENTS

- Fuel cell cartridges must be securely cushioned in the outer packagings.
- Packagings must meet the Packing Group II performance requirements.

OUTER PACKAGINGS

Boxes

Aluminium (4B)
Fibreboard (4G)
Natural wood (4C1, 4C2)
Other metal (4N)
Plastics (4H1, 4H2)
Plywood (4D)
Reconstituted wood (4F)
Steel (4A)

Drums

Aluminium (1B2)
Fibre (1G)
Plastics (1H2)
Plywood (1D)
Steel (1A2)

Jerricans

Aluminium (3B2)
Plastics (3H2)
Steel (3A2)

Packing Instruction Y215

Limited quantities for UN 3478 and 3479 only

General requirements

Part 3;4 requirements must be met.

Single packagings are not permitted for limited quantities.

For the purpose of this packing instruction, a fuel cell cartridge is considered an inner packaging.

1) Compatibility requirements

- Substances must be compatible with their packagings as required by 4;1.1.3.

<i>UN number and name</i>	<i>Maximum quantity per package</i>
UN 3478 Fuel cell cartridges containing liquefied flammable gas	0.5 kg of fuel cell cartridges
UN 3479 Fuel cell cartridges containing hydrogen in metal hydride	

ADDITIONAL PACKING REQUIREMENTS

- Fuel cell cartridges must be securely cushioned in the outer packagings.
- Fuel cell cartridges must not exceed 120 ml water capacity each.

OUTER PACKAGINGS*Boxes*

Aluminium
Fibreboard
Natural wood
Other metal
Plastics
Plywood
Reconstituted wood
Steel

Drums

Aluminium
Fibre
Plastics
Plywood
Steel

Jerricans

Aluminium
Plastics
Steel

Packing Instruction 216

Passenger and cargo aircraft for UN 3478 and 3479 (contained in equipment) only

General requirements

Part 4;1.1.1 and 1.1.8 requirements must be met, including:

1) **Compatibility requirements**

- Substances must be compatible with their packagings as required by 4;1.1.3.

<i>UN number and name</i>	<i>Quantity — passenger</i>	<i>Quantity — cargo</i>
UN 3478 Fuel cell cartridges contained in equipment , containing liquefied flammable gas	1 kg of fuel cell cartridges	15 kg of fuel cell cartridges
UN 3479 Fuel cell cartridges contained in equipment , containing hydrogen in metal hydride		

ADDITIONAL PACKING REQUIREMENTS

- Fuel cell cartridges that are contained in equipment must be protected against short circuit and the equipment must be protected against inadvertent operation.
- Equipment must be securely cushioned in the outer packagings.
- Fuel cell systems must not charge batteries during transport.
- On passenger aircraft, each fuel cell system and each fuel cell cartridge must conform to IEC 62282-6-100 Ed. 1, including Amendment 1, or a standard approved by the appropriate authority of the State of Origin.

OUTER PACKAGINGS*Boxes**Drums**Jerricans*

Strong outer packagings

Packing Instruction 217

Passenger and cargo aircraft for UN 3478 and 3479 (packed with equipment) only

General requirements

Part 4;1.1.1 and 1.1.8 requirements must be met, including:

1) Compatibility requirements

- Substances must be compatible with their packagings as required by 4;1.1.3.

<i>UN number and name</i>	<i>Quantity — passenger</i>	<i>Quantity — cargo</i>
UN 3478 Fuel cell cartridges packed with equipment , containing liquefied flammable gas	1 kg of fuel cell cartridges	15 kg of fuel cell cartridges
UN 3479 Fuel cell cartridges packed with equipment , containing hydrogen in metal hydride		

ADDITIONAL PACKING REQUIREMENTS

- When fuel cell cartridges are packed with equipment, they must be packed in intermediate packagings together with the equipment they are capable of powering.
- The maximum number of fuel cell cartridges in the intermediate packaging must be the minimum number required to power the equipment, plus 2 spares.
- The fuel cell cartridges and the equipment must be packed with cushioning material or divider(s) or inner packaging so that the fuel cell cartridges are protected against damage that may be caused by the movement or placement of the equipment and the cartridges within the packaging.

OUTER PACKAGINGS

Boxes

Drums

Jerricans

Strong outer packagings

Packing Instruction 218

Passenger and cargo aircraft for UN 3500, 3501, 3502, 3503, 3504 and 3505 only

General requirements

The general requirements of 4;4.1 applicable to cylinders must be met. Cylinders, constructed as specified in 6;5 are authorized for the transport of UN 3500, UN 3501, UN 3502, UN 3503, UN 3504 and UN 3505. Cylinders other than UN marked and certified cylinders may be used if the design, construction, testing, approval and markings conform to the requirements of the appropriate national authority of the State in which they are approved and filled. The substances contained must be permitted in cylinders and permitted for air transport according to these Instructions. Cylinders for which prescribed periodic tests have become due must not be charged and offered for transport until such retests have been successfully completed.

Compatibility requirements

- The construction materials of the cylinders and their accessories must be compatible with the contents and must not react to form harmful or dangerous compounds therewith.
- The necessary steps must be taken to prevent dangerous reactions (i.e. polymerization or decomposition) during transport. If necessary, stabilization or addition of an inhibitor may be required.

Periodic inspection

- The maximum test period for periodic inspection of the cylinders must be 5 years.

ADDITIONAL PACKING REQUIREMENTS

- Cylinders must be so filled that at 50°C the non-gaseous phase does not exceed 95% of their water capacity and they are not completely filled at 60°C. When filled, the internal pressure at 65°C must not exceed the test pressure of the cylinders. The vapour pressures and volumetric expansion of all substances in the cylinders must be taken into account.
- Spray application equipment (such as a hose and wand assembly) must not be connected during transport.
- The minimum test pressure must be in accordance with Packing Instruction 200 for the propellant but must not be less than 20 bar.
- Non-refillable cylinders used may have a water capacity in litres not exceeding 1 000 litres divided by the test pressure expressed in bars provided capacity and pressure restrictions of the construction standard comply with ISO 11118:1999, which limits the maximum capacity to 50 litres.

OUTER PACKAGINGS

Boxes

Drums

Jerricans

Strong outer packagings

+

Packing Instruction 219

For cylinders, the general packing requirements of 4;1.1 and 4;4.1.1 must be met.

This Instruction applies to Class 2 adsorbed gases.

- 1) The following packagings are permitted provided the general packing requirements of 4.1.1 are met:
Cylinders specified in 6;5 and in accordance with ISO 11513:2011 or ISO 9809-1:2010.
- 2) The pressure of each filled cylinder must be less than 101.3 kPa at 20°C and less than 300 kPa at 50°C.
- 3) The minimum test pressure of the cylinder is 21 bar.
- 4) The minimum burst pressure of the cylinder is 94.5 bar.
- 5) The internal pressure at 65°C of the filled cylinder must not exceed the test pressure of the cylinder.
- 6) The adsorbent material must be compatible with the cylinder and must not form harmful or dangerous compounds with the gas to be adsorbed. The gas in combination with the adsorbent material must not affect or weaken the cylinder or cause a dangerous reaction (e.g. a catalyzing reaction).
- 7) The quality of the adsorbent material must be verified at the time of each fill to assure the pressure and chemical stability requirements of this packing instruction are met each time an adsorbed gas package is offered for transport.
- 8) The adsorbent material must not meet the criteria of any of the classes or divisions in these Instructions.
- 9) The filling procedure must be in accordance with Annex A of ISO 11513:2011.
- 10) The maximum period for periodic inspections is five years.
- 11) The construction materials of the cylinders and their accessories must be compatible with the contents and must not react to form harmful or dangerous compounds therewith.

Chapter 5

CLASS 3 — FLAMMABLE LIQUIDS

5.1 PACKING INSTRUCTIONS

Packing Instructions Y340 – Y344

Limited quantities
Passenger and cargo aircraft

General requirements

Part 4, Chapter 1 requirements must be met (except that 4;1.1.2, 1.1.9 c), 1.1.9 e), 1.1.16, 1.1.18 and 1.1.20 do not apply), including:

1) Compatibility requirements

- Substances must be compatible with their packagings as required by 4;1.1.3.
- Metal packagings must be corrosion resistant or be protected against corrosion for substances with a Class 8 subsidiary risk.

2) Closure requirements

- Closures must meet the requirements of 4;1.1.4.

3) Limited quantity requirements

- Part 3, Chapter 4 requirements must be met, including:
 - the capability of the package to pass a 1.2 m drop test;
 - a 24-hour stacking test; and
 - inner packagings for liquids must be capable of passing a pressure differential test (4;1.1.6).

COMBINATION PACKAGINGS						
<i>Packing instruction</i>	<i>Packing group</i>	<i>Inner packaging (see 6;3.2)</i>	<i>Inner packaging quantity (per receptacle)</i>	<i>Total quantity per package</i>	<i>Total gross mass per package</i>	SINGLE PACKAGINGS
Y340	II	Glass	0.5 L	0.5 L	30 kg	No
		Plastics	0.5 L			
		Metal	0.5 L			
Y341	II	Glass	0.5 L	1.0 L		No
		Plastics	0.5 L			
		Metal	0.5 L			
Y342	III	Glass	1.0 L	1.0 L		No
		Plastics	1.0 L			
		Metal	1.0 L			
Y343	III	Glass	1.0 L	2.0 L		No
		Plastics	1.0 L			
		Metal	1.0 L			
Y344	III	Glass	2.5 L	10.0 L	No	
		Plastics	5.0 L			
		Metal	5.0 L			

OUTER PACKAGINGS OF COMBINATION PACKAGINGS (see 6;3.1)*Boxes*

Aluminium
Fibreboard
Natural wood
Other metal
Plastics
Plywood
Reconstituted wood
Steel

Drums

Aluminium
Fibre
Other metal
Plastics
Plywood
Steel

Jerricans

Aluminium
Plastics
Steel

Packing Instructions 350 – 355

Passenger aircraft

General requirements

Part 4, Chapter 1 requirements must be met, including:

1) Compatibility requirements

- Substances must be compatible with their packagings as required by 4;1.1.3.
- Metal packagings must be corrosion resistant or be protected against corrosion for substances with a Class 8 subsidiary risk.

2) Closure requirements

- Closures must meet the requirements of 4;1.1.4.

COMBINATION PACKAGINGS					SINGLE PACKAGINGS
<i>Packing instruction</i>	<i>Packing group</i>	<i>Inner packaging (see 6;3.2)</i>	<i>Inner packaging quantity (per receptacle)</i>	<i>Total quantity per package</i>	
350	I	Glass	0.5 L	0.5 L	No
		Plastics	Forbidden		
		Metal	0.5 L		
351	I	Glass	0.5 L	1 L	No
		Plastics	Forbidden		
		Metal	1.0 L		
352	II	Glass	1.0 L	1 L	No
		Plastics	1.0 L		
		Metal	1.0 L		
353	II	Glass	1.0 L	5 L	No
		Plastics	5.0 L		
		Metal	5.0 L		
354	III	Glass	2.5 L	5 L	5 L
		Plastics	5.0 L		
		Metal	5.0 L		
355	III	Glass	2.5 L	60 L	60 L
		Plastics	10.0 L		
		Metal	10.0 L		

ADDITIONAL PACKING REQUIREMENTS FOR COMBINATION PACKAGINGS*Packing Group I*

- Inner packagings must be packed with sufficient absorbent material to absorb the entire contents of the inner packagings and placed in a rigid leakproof receptacle before packing in outer packagings.

Packing Group III

- Packagings must meet the Packing Group II performance requirements if the substance has a Class 8 subsidiary risk.

OUTER PACKAGINGS OF COMBINATION PACKAGINGS (see 6;3.1)

<i>Boxes</i>	<i>Drums</i>	<i>Jerricans</i>
Aluminium (4B)	Aluminium (1B1, 1B2)	Aluminium (3B1, 3B2)
Fibreboard (4G)	Fibre (1G)	Plastics (3H1, 3H2)
Natural wood (4C1, 4C2)	Other metal (1N1, 1N2)	Steel (3A1, 3A2)
Other metal (4N)	Plastics (1H1, 1H2)	
Plastics (4H1, 4H2)	Plywood (1D)	
Plywood (4D)	Steel (1A1, 1A2)	
Reconstituted wood (4F)		
Steel (4A)		

ADDITIONAL PACKING REQUIREMENTS FOR SINGLE PACKAGINGS*Packing Group III*

- Packagings must meet the Packing Group II performance requirements if the substance has a Class 8 subsidiary risk.

SINGLE PACKAGINGS FOR PACKING GROUP III (PI 354 OR PI 355)

<i>Composites</i>	<i>Cylinders</i>	<i>Drums</i>	<i>Jerricans</i>
All (see 6;3.1.18)	See 4;2.7	Aluminium (1B1, 1B2) Other metal (1N1, 1N2) Plastics (1H1, 1H2) Steel (1A1, 1A2)	Aluminium (3B1, 3B2) Plastics (3H1, 3H2) Steel (3A1, 3A2)

Packing Instructions 360 – 366

Cargo aircraft only

General requirements

Part 4, Chapter 1 requirements must be met, including:

1) Compatibility requirements

- Substances must be compatible with their packagings as required by 4;1.1.3.
- Metal packagings must be corrosion resistant or be protected against corrosion for substances with a Class 8 subsidiary risk.

2) Closure requirements

- Closures must meet the requirements of 4;1.1.4.

COMBINATION PACKAGINGS					SINGLE PACKAGINGS
<i>Packing instruction</i>	<i>Packing group</i>	<i>Inner packaging (see 6;3.2)</i>	<i>Inner packaging quantity (per receptacle)</i>	<i>Total quantity per package</i>	
360	I	Glass	1.0 L	2.5 L	2.5 L
		Plastics	Forbidden		
		Metal	2.5 L		
361	I	Glass	1.0 L	30 L	30 L
		Plastics	Forbidden		
		Metal	5.0 L		
362	II	Glass	1.0 L	5 L	5 L
		Plastics	1.0 L		
		Metal	1.0 L		
363	II	Glass	2.5 L	5 L	5 L
		Plastics	2.5 L		
		Metal	5.0 L		
364	II	Glass	2.5 L	60 L	60 L
		Plastics	5.0 L		
		Metal	10.0 L		
365	III	Glass	5.0 L	60 L	60 L
		Plastics	10.0 L		
		Metal	25.0 L		
366	III	Glass	5.0 L	220 L	220 L
		Plastics	10.0 L		
		Metal	25.0 L		

ADDITIONAL PACKING REQUIREMENTS FOR COMBINATION PACKAGINGS

Packing Group I

- Inner packagings must be packed with sufficient absorbent material to absorb the entire contents of the inner packagings and placed in a rigid leakproof receptacle before packing in outer packagings.

Packing Group III

- Packagings must meet the Packing Group II performance requirements if the substance has a Class 8 subsidiary risk.

OUTER PACKAGINGS OF COMBINATION PACKAGINGS (see 6;3.1)*Boxes*

Aluminium (4B)
 Fibreboard (4G)
 Natural wood (4C1, 4C2)
 Other metal (4N)
 Plastics (4H1, 4H2)
 Plywood (4D)
 Reconstituted wood (4F)
 Steel (4A)

Drums

Aluminium (1B1, 1B2)
 Fibre (1G)
 Other metal (1N1, 1N2)
 Plywood (1D)
 Plastics (1H1, 1H2)
 Steel (1A1, 1A2)

Jerricans

Aluminium (3B1, 3B2)
 Other metal (3N2)
 Plastics (3H1, 3H2)
 Steel (3A1, 3A2)

ADDITIONAL PACKING REQUIREMENTS FOR SINGLE PACKAGINGS*Packing Group III*

- Packagings must meet the Packing Group II performance requirements if the substance has a Class 8 subsidiary risk.

SINGLE PACKAGINGS FOR PACKING GROUP I*Composites*

All (see 6;3.1.18)

Cylinders

See 4;2.7

Drums

Aluminium (1B1)
 Other metal (1N1)
 Steel (1A1)

Jerricans

Aluminium (3B1)
 Steel (3A1)

SINGLE PACKAGINGS FOR PACKING GROUP II*Composites*

All (see 6;3.1.18)

Cylinders

See 4;2.7

Drums

Aluminium (1B1)
 Other metal (1N1)
 Plastics (1H1)
 Steel (1A1)

Jerricans

Aluminium (3B1)
 Plastics (3H1)
 Steel (3A1)

SINGLE PACKAGINGS FOR PACKING GROUP III ONLY*Composites*

All (see 6;3.1.18)

Cylinders

See 4;2.7

Drums

Aluminium (1B1, 1B2)
 Other metal (1N1, 1N2)
 Plastics (1H1, 1H2)
 Steel (1A1, 1A2)

Jerricans

Aluminium (3B1, 3B2)
 Plastics (3H1, 3H2)
 Steel (3A1, 3A2)

Packing Instruction 370

Passenger and cargo aircraft for UN 3269 (Packing Group II or III) only

General requirements

Part 4, Chapter 1 requirements must be met, including:

1) Compatibility requirements

- Substances must be compatible with their packagings as required by 4;1.1.3.
- Metal packagings must be corrosion resistant or be protected against corrosion for substances with a Class 8 subsidiary risk.

2) Closure requirements

- Closures must meet the requirements of 4;1.1.4.

COMBINATION PACKAGINGS						SINGLE PACKAGINGS
<i>Packing conditions</i>	<i>Inner packaging (see 6;3.2)</i>	<i>Inner packaging quantity (per receptacle) — for base liquid material</i>	<i>Inner packaging quantity (per receptacle) — for liquid activator</i>	<i>Inner packaging quantity (per receptacle) — for solid activator</i>	<i>Total quantity per package</i>	
Activator (Organic peroxide)	Plastics*	n/a	125 mL	500 g	5 kg	No
	Metal*	n/a	125 mL	500 g		
Base material Class 3 Packing Group II	Glass	1.0 L	n/a	n/a		
	Plastics	5.0 L	n/a	n/a		
	Metal	5.0 L	n/a	n/a		
Activator (Organic peroxide)	Plastics*	n/a	125 mL	500 g		
	Metal*	n/a	125 mL	500 g		
Base material Class 3 Packing Group III	Glass	2.5 L	n/a	n/a		
	Plastics	10.0 L	n/a	n/a		
	Metal	10.0 L	n/a	n/a		

*Including tubes.

The total quantity of kits per package is to be calculated on a one-to-one basis of their volume, i.e. 1 L equal to 1 kg.

ADDITIONAL PACKING REQUIREMENTS FOR COMBINATION PACKAGINGS

The components may be placed in the same outer packaging provided that they will not interact dangerously in the event of leakage (see 4;1.1.7).

OUTER PACKAGINGS OF COMBINATION PACKAGINGS (see 6;3.1)

Boxes

Aluminium (4B)
Fibreboard (4G)
Natural wood (4C1, 4C2)
Other metal (4N)
Plastics (4H1, 4H2)
Plywood (4D)
Reconstituted wood (4F)
Steel (4A)

Drums

Aluminium (1B1, 1B2)
Fibre (1G)
Other metal (1N1, 1N2)
Plastics (1H1, 1H2)
Steel (1A1, 1A2)

Jerricans

Aluminium (3B1, 3B2)
Plastics (3H1, 3H2)
Steel (3A1, 3A2)

Packing Instruction Y370

Limited quantities
Passenger and cargo aircraft for UN 3269 (Packing Group II or III) only

General requirements

Part 4, Chapter 1 requirements must be met (except that 4;1.1.2, 1.1.9 c), 1.1.9 e), 1.1.16, 1.1.18 and 1.1.20 do not apply), including:

1) Compatibility requirements

- Substances must be compatible with their packagings as required by 4;1.1.3.
- Metal packagings must be corrosion resistant or be protected against corrosion for substances with a Class 8 subsidiary risk.

2) Closure requirements

- Closures must meet the requirements of 4;1.1.4.

3) Limited quantity requirements

- Part 3, Chapter 4 requirements must be met, including:
 - the capability of the package to pass a 1.2 m drop test;
 - a 24-hour stacking test; and
 - inner packagings for liquids must be capable of passing a pressure differential test (4;1.1.6).

COMBINATION PACKAGINGS							SINGLE PACKAGINGS
Packing conditions	Inner packaging (see 6;3.2)	Inner packaging quantity (per receptacle) — for base liquid material	Inner packaging quantity (per receptacle) — for liquid activator	Inner packaging quantity (per receptacle) — for solid activator	Total quantity per package	Total gross mass per package	
Activator (Organic peroxide)	Plastics*	n/a	30 mL	100 g	1 kg	30 kg	No
	Metal*	n/a	30 mL	100 g			
Base material Class 3 Packing Group II	Glass	1.0 L	n/a	n/a			
	Plastics	1.0 L	n/a	n/a			
	Metal	1.0 L	n/a	n/a			
Activator (Organic peroxide)	Plastics*	n/a	30 mL	100 g			
	Metal*	n/a	30 mL	100 g			
Base material Class 3 Packing Group III	Glass	2.5 L	n/a	n/a			
	Plastics	5.0 L	n/a	n/a			
	Metal	5.0 L	n/a	n/a			

*Including tubes.

The total quantity of kits per package is to be calculated on a one-to-one basis of their volume, i.e. 1 L equal to 1 kg.

ADDITIONAL PACKING REQUIREMENTS FOR COMBINATION PACKAGINGS

The components may be placed in the same outer packaging provided that they will not interact dangerously in the event of leakage (see 4;1.1.7).

OUTER PACKAGINGS OF COMBINATION PACKAGINGS (see 6;3.1)*Boxes*

Aluminium
Fibreboard
Natural wood
Other metal
Plastics
Plywood
Reconstituted wood
Steel

Drums

Aluminium
Fibre
Other metal
Plastics
Steel

Jerricans

Aluminium
Plastics
Steel

Packing Instruction 371

Passenger and cargo aircraft for UN 1204 and UN 3064 only

General requirements

Part 4, Chapter 1 requirements must be met, including:

1) Compatibility requirements

— Substances must be compatible with their packagings as required by 4;1.1.3.

2) Closure requirements

— Closures must meet the requirements of 4;1.1.4.

COMBINATION PACKAGINGS					SINGLE PACKAGINGS
<i>UN number and proper shipping name</i>	<i>Inner packaging (see 6;3.2)</i>	<i>Inner packaging quantity (per receptacle)</i>	<i>Total quantity per package — passenger</i>	<i>Total quantity per package — cargo</i>	
UN 1204 Nitroglycerin solution in alcohol with not more than 1% nitroglycerin (Packing Group II)	Glass	1.0 L	5 L	60 L	No
	Plastics	1.0 L			
	Metal	1.0 L			
UN 3064 Nitroglycerin solution in alcohol with more than 1% but not more than 5% nitroglycerin (Packing Group II)	Metal	1.0 L	Forbidden	5 L	No

ADDITIONAL PACKING REQUIREMENTS FOR COMBINATION PACKAGINGS

For UN 1204 and UN 3064

Inner packagings must be completely surrounded with absorbent cushioning material of sufficient quantity to absorb the entire liquid content.

For UN 3064

Wooden boxes (4C1, 4C2, 4D or 4F) must be used as the outer packaging and must be completely lined with a suitable material impervious to water, alcohol and nitroglycerin.

OUTER PACKAGINGS OF COMBINATION PACKAGINGS (see 6;3.1)*Boxes*

Aluminium (4B)
 Fibreboard (4G)
 Natural wood (4C1, 4C2)
 Other metal (4N)
 Plastics (4H1, 4H2)
 Plywood (4D)
 Reconstituted wood (4F)
 Steel (4A)

Drums

Aluminium (1B1, 1B2)
 Fibre (1G)
 Other metal (1N1, 1N2)
 Plastics (1H1, 1H2)
 Steel (1A1, 1A2)

Jerricans

Aluminium (3B1, 3B2)
 Plastics (3H1, 3H2)
 Steel (3A1, 3A2)

Packing Instruction 372

Cargo aircraft only for UN 3165 only

General requirements

Part 4, Chapter 1 requirements must be met, including:

1) Compatibility requirements

— Substances must be compatible with their packagings as required by 4;1.1.3.

2) Closure requirements

— Closures must meet the requirements of 4;1.1.4.

ADDITIONAL PACKING REQUIREMENTS

UN 3165 **Aircraft hydraulic power unit fuel tank** (containing a mixture of anhydrous hydrazine and methyl hydrazine) (M86 fuel) and designed for installation as complete units in aircraft are acceptable, subject to either of the following conditions:

- a) the unit must consist of an aluminium pressure receptacle made from tubing and having welded heads. Primary containment of the fuel within this receptacle must consist of a welded aluminium bladder having a maximum internal volume of 46 L. The outer receptacle must have a minimum design gauge pressure of 1 275 kPa and a minimum burst gauge pressure of 2 755 kPa. Each receptacle must be leak-checked during manufacture and before shipment and must be found leakproof. The complete inner unit must be securely packed in non-combustible cushioning material, such as vermiculite, in a strong outer tightly closed metal packaging which will adequately protect all fittings. Maximum quantity of fuel per unit and package is 42 L; or
- b) the unit must consist of an aluminium pressure receptacle. Primary containment of the fuel within this receptacle must consist of a welded hermetically sealed fuel compartment with an elastomeric bladder having a maximum internal volume of 46 L. The pressure receptacle must have a minimum design gauge pressure of 2 860 kPa and a minimum burst gauge pressure of 5 170 kPa. Each receptacle must be leak-checked during manufacture and before shipment and must be found leakproof. The complete inner unit must be securely packed in non-combustible cushioning material, such as vermiculite, in a strong outer tightly closed metal packaging which will adequately protect all fittings. Maximum quantity of fuel per unit and package is 42 L.

Note.— This packing instruction is the same as UN packing instruction P301.

Packing Instruction 373

Passenger and cargo aircraft for UN 1228 (Packing Group II or III) only

General requirements

Part 4, Chapter 1 requirements must be met, including:

1) Compatibility requirements

- Substances must be compatible with their packagings as required by 4;1.1.3.

2) Closure requirements

- Closures must meet the requirements of 4;1.1.4.

COMBINATION PACKAGINGS							SINGLE PACKAGINGS	
UN number and proper shipping name	Packing group	Inner packaging (see 6;3.2)	Inner packaging quantity (per receptacle) — passenger	Inner packaging quantity (per receptacle) — cargo	Total quantity per package — passenger	Total quantity per package — cargo	Passenger	Cargo
UN 1228 Mercaptans, liquid, flammable, toxic, n.o.s.*	II	Glass	Forbidden	5.0 L	Forbidden	60 L	No	60 L
		Plastics		5.0 L				
		Metal		5.0 L				
	III	Glass	1.0 L	5.0 L	5 L	220 L	No	220 L
		Plastics	1.0 L	5.0 L				
		Metal	1.0 L	5.0 L				

ADDITIONAL PACKING REQUIREMENTS FOR COMBINATION PACKAGINGS

Glass inner packagings must be packed with sufficient absorbent material to absorb the entire contents of the inner packagings and placed in a rigid leakproof receptacle before packing in outer packagings.

OUTER PACKAGINGS OF COMBINATION PACKAGINGS

Boxes

Aluminium (4B)
Fibreboard (4G)
Natural wood (4C1, 4C2)
Other metal (4N)
Plastics (4H1, 4H2)
Plywood (4D)
Reconstituted wood (4F)
Steel (4A)

Drums

Aluminium (1B1, 1B2)
Fibre (1G)
Other metal (1N1, 1N2)
Plastics (1H1, 1H2)
Steel (1A1, 1A2)

Jerricans

Aluminium (3B1, 3B2)
Plastics (3H1, 3H2)
Steel (3A1, 3A2)

SINGLE PACKAGINGS FOR CARGO AIRCRAFT ONLY

Composites

All (see 6;3.1.18)

Cylinders

See 4;2.7

Drums

Aluminium (1B1, 1B2)
Other metal (1N1, 1N2)
Plastics (1H1, 1H2)
Steel (1A1, 1A2)

Jerricans

Aluminium (3B1, 3B2)
Plastics (3H1, 3H2)
Steel (3A1, 3A2)

Packing Instruction Y373

Limited quantities
Passenger and cargo aircraft for UN 1228 (Packing Group III) only

General requirements

Part 4, Chapter 1 requirements must be met (except that 4;1.1.2, 1.1.9 c), 1.1.9 e), 1.1.16, 1.1.18 and 1.1.20 do not apply), including:

1) Compatibility requirements

- Substances must be compatible with their packagings as required by 4;1.1.3.

2) Closure requirements

- Closures must meet the requirements of 4;1.1.4.

3) Limited quantity requirements

- Part 3, Chapter 4 requirements must be met, including:
 - the capability of the package to pass a 1.2 m drop test;
 - a 24-hour stacking test; and
 - inner packagings for liquids must be capable of passing a pressure differential test (4;1.1.6).

COMBINATION PACKAGINGS						SINGLE PACKAGINGS
<i>UN number and proper shipping name</i>	<i>Packing group</i>	<i>Inner packaging (see 6;3.2)</i>	<i>Inner packaging quantity (per receptacle)</i>	<i>Total quantity per package</i>	<i>Total gross mass per package</i>	
UN 1228 Mercaptans, liquid, flammable, toxic, n.o.s.*	III	Glass	0.5 L	1 L	30 kg	No
		Plastics	0.5 L			
		Metal	0.5 L			

ADDITIONAL PACKING REQUIREMENTS FOR COMBINATION PACKAGINGS

Glass inner packagings must be packed with sufficient absorbent material to absorb the entire contents of the inner packagings and placed in a rigid leakproof receptacle before packing in outer packagings.

OUTER PACKAGINGS OF COMBINATION PACKAGINGS (see 6;3.1)

Boxes

Aluminium
Fibreboard
Natural wood
Other metal
Plastics
Plywood
Reconstituted wood
Steel

Drums

Aluminium
Fibre
Other metal
Plastics
Steel

Jerricans

Aluminium
Plastics
Steel

Packing Instruction 374

Passenger and cargo aircraft for UN 3473 only

General requirements

Part 4;1.1.1, 1.1.2 and 1.1.8 requirements must be met, including:

1) Compatibility requirements

- Substances must be compatible with their packagings as required by 4;1.1.3.

<i>UN number and proper shipping name</i>	<i>Quantity — passenger</i>	<i>Quantity — cargo</i>
UN 3473 Fuel cell cartridges	5 kg of fuel cell cartridges	50 kg of fuel cell cartridges

ADDITIONAL PACKING REQUIREMENTS

- Fuel cell cartridges must be securely cushioned in the outer packagings.
- Packagings must meet the Packing Group II performance requirements.

OUTER PACKAGINGS

Boxes

Aluminium (4B)
Fibreboard (4G)
Natural wood (4C1, 4C2)
Other metal (4N)
Plastics (4H1, 4H2)
Plywood (4D)
Reconstituted wood (4F)
Steel (4A)

Drums

Aluminium (1B2)
Fibre (1G)
Other metal (1N2)
Plastics (1H2)
Plywood (1D)
Steel (1A2)

Jerricans

Steel (3A2)
Plastics (3H2)
Aluminium (3B2)

Packing Instruction Y374

Limited quantities for UN 3473 only

General requirements

Part 3;4 requirements must be met.

Single packagings are not permitted for limited quantities.

For the purpose of this packing instruction, a fuel cell cartridge is considered an inner packaging.

1) Compatibility requirements

- Substances must be compatible with their packagings as required by 4;1.1.3.

<i>UN number and name</i>	<i>Maximum quantity per package</i>
UN 3473 Fuel cell cartridges , containing flammable liquids	2.5 kg of fuel cell cartridges

ADDITIONAL PACKING REQUIREMENTS

- Fuel cell cartridges must be securely cushioned in the outer packagings.
- Fuel cell cartridges must not exceed 0.5 L of flammable liquid fuel per cartridge.

OUTER PACKAGINGS*Boxes*

Aluminium
Fibreboard
Natural wood
Other metal
Plastics
Plywood
Reconstituted wood
Steel

Drums

Aluminium
Fibre
Other metal
Plastics
Plywood
Steel

Jerricans

Aluminium
Plastics
Steel

Packing Instruction 375

Passenger and cargo aircraft for UN 3473 (contained in equipment) only

General requirements

Part 4;1.1.1 and 1.1.8 requirements must be met, including:

1) Compatibility requirements

- Substances must be compatible with their packagings as required by 4;1.1.3.

<i>UN number and proper shipping name</i>	<i>Quantity — passenger</i>	<i>Quantity — cargo</i>
UN 3473 Fuel cell cartridges contained in equipment	5 kg of fuel cell cartridges	50 kg of fuel cell cartridges

ADDITIONAL PACKING REQUIREMENTS

- Fuel cell cartridges that are contained in equipment must be protected against short circuit and the equipment must be protected against inadvertent operation.
- Equipment must be securely cushioned in the outer packagings.
- Fuel cell systems must not charge batteries during transport.
- On passenger aircraft, each fuel cell system and each fuel cell cartridge must conform to IEC 62282-6-100 Ed. 1, including Amendment 1, or a standard approved by the appropriate authority of the State of Origin.

OUTER PACKAGINGS*Boxes**Drums**Jerricans*

Strong outer packagings

Packing Instruction 376

Passenger and cargo aircraft for UN 3473 (packed with equipment) only

General requirements

Part 4;1.1.1 and 1.1.8 requirements must be met, including:

1) Compatibility requirements

- Substances must be compatible with their packagings as required by 4;1.1.3.

<i>UN number and proper shipping name</i>	<i>Quantity — passenger</i>	<i>Quantity — cargo</i>
UN 3473 Fuel cell cartridges packed with equipment	5 kg of fuel cell cartridges	50 kg of fuel cell cartridges

ADDITIONAL PACKING REQUIREMENTS

- When fuel cell cartridges are packed with equipment, they must be packed in intermediate packagings together with the equipment they are capable of powering.
- The maximum number of fuel cell cartridges in the intermediate packaging must be the minimum number required to power the equipment, plus 2 spares.
- The fuel cell cartridges and the equipment must be packed with cushioning material or divider(s) or inner packaging so that the fuel cell cartridges are protected against damage that may be caused by the movement or placement of the equipment and the cartridges within the packaging.

OUTER PACKAGINGS

Boxes

Drums

Jerricans

Strong outer packagings

Packing Instruction 377

Cargo aircraft only for Chlorosilanes

General requirements

Part 4, Chapter 1 requirements must be met, including:

1) Compatibility requirements

- Substances must be compatible with their packagings as required by 4;1.1.3.
- Metal packagings must be corrosion resistant or be protected against corrosion.

2) Closure requirements

- Closures must meet the requirements of 4;1.1.4.

COMBINATION PACKAGINGS				SINGLE PACKAGINGS
<i>UN number</i>	<i>Inner packaging (see 6;3.2)</i>	<i>Net quantity per inner packaging</i>	<i>Total quantity per package</i>	
UN 1162, UN 1196, UN 1250, UN 1298, UN 1305, UN 2985	Glass	1.0 L	5.0 L	5.0 L
	Plastics	Forbidden		
	Steel	5.0 L		

OUTER PACKAGINGS OF COMBINATION PACKAGINGS*Boxes*

Fibreboard (4G)
 Natural wood (4C1, 4C2)
 Plastics (4H1, 4H2)
 Plywood (4D)
 Reconstituted wood (4F)
 Steel (4A)

Drums

Fibre (1G)
 Plastics (1H1, 1H2)
 Plywood (1D)
 Steel (1A1, 1A2)

SINGLE PACKAGINGS*Composites*

Plastic receptacle in steel drum (6HA1)

Cylinders

Steel (as permitted by 4;2.7)

Drums

Steel (1A1)

Jerricans

Steel (3A1)

Chapter 6

CLASS 4 — FLAMMABLE SOLIDS; SUBSTANCES LIABLE TO SPONTANEOUS COMBUSTION; SUBSTANCES WHICH, IN CONTACT WITH WATER, EMIT FLAMMABLE GASES

6.1 GENERAL REQUIREMENTS FOR SELF-REACTIVE SUBSTANCES

Packagings for self-reactive substances must conform to the requirements of 6;1, 6;2, 6;3 and 6;4 and must meet the test requirements of 6;4 for Packing Group II.

6.2 PACKING INSTRUCTIONS

Packing Instructions Y440 – Y443

Limited quantities
Passenger and cargo aircraft

General requirements

Part 4, Chapter 1 requirements must be met (except that 4;1.1.2, 1.1.9 c), 1.1.9 e), 1.1.16, 1.1.18 and 1.1.20 do not apply), including:

1) Compatibility requirements

- Substances must be compatible with their packagings as required by 4;1.1.3.
- Metal packagings must be corrosion resistant or be protected against corrosion for substances with a Class 8 subsidiary risk.

2) Closure requirements

- Closures must meet the requirements of 4;1.1.4.

3) Limited quantity requirements

- Part 3, Chapter 4 requirements must be met, including:
 - the capability of the package to pass a 1.2 m drop test; and
 - a 24-hour stacking test.

COMBINATION PACKAGINGS						SINGLE PACKAGINGS
Packing instruction	Packing group	Inner packaging (see 6;3.2)	Inner packaging quantity (per receptacle)	Total quantity per package	Total gross mass per package	
Y440	II	Glass	0.5 kg	1 kg	30 kg	No
		Plastics	0.5 kg			
		Metal	0.5 kg			
		Plastic bag	0.5 kg			
Y441	II	Glass	0.5 kg	5 kg	30 kg	No
		Plastics	0.5 kg			
		Metal	0.5 kg			
		Plastic bag	0.5 kg			
Y442	III	Glass	1.0 kg	5 kg	30 kg	No
		Plastics	1.0 kg			

		Metal	1.0 kg			
		Plastic bag	1.0 kg			
Y443	III	Glass	1.0 kg	10 kg		No
		Plastics	1.0 kg			
		Metal	1.0 kg			
		Plastic bag	1.0 kg			

OUTER PACKAGINGS OF COMBINATION PACKAGINGS (see 6;3.1)
Boxes

Aluminium
Fibreboard
Natural wood
Other metal
Plastics
Plywood
Reconstituted wood
Steel

Drums

Aluminium
Fibre
Plastics
Plywood
Other metal
Steel

Jerricans

Aluminium
Plastics
Steel

Packing Instructions 445 – 446

Passenger aircraft

General requirements

Part 4, Chapter 1 requirements must be met, including:

1) Compatibility requirements

- Substances must be compatible with their packagings as required by 4;1.1.3.
- Metal packagings must be corrosion resistant or be protected against corrosion for substances with a Class 8 subsidiary risk.

2) Closure requirements

- Closures must meet the requirements of 4;1.1.4.

COMBINATION PACKAGINGS					SINGLE PACKAGINGS
Packing instruction	Packing group	Inner packaging (see 6;3.2)	Inner packaging quantity (per receptacle)	Total quantity per package	
—	I	Forbidden (only permitted for wetted explosives, see Packing Instruction 451)			
445	II	Glass	1.0 kg	15 kg	No
		Plastics	2.5 kg		
		Metal	2.5 kg		
		Plastic bag	1.0 kg		
446	III	Glass	5.0 kg	25 kg	No
		Plastics	10.0 kg		
		Metal	10.0 kg		
		Plastic bag	5.0 kg		

ADDITIONAL PACKING REQUIREMENTS FOR COMBINATION PACKAGINGS*Packing Group III*

— Packagings must meet the Packing Group II performance requirements.

OUTER PACKAGINGS OF COMBINATION PACKAGINGS (see 6;3.1)

<i>Boxes</i>	<i>Drums</i>	<i>Jerricans</i>
Aluminium (4B)	Aluminium (1B1, 1B2)	Aluminium (3B1, 3B2)
Fibreboard (4G)	Fibre (1G)	Plastics (3H1, 3H2)
Natural wood (4C1, 4C2)	Other metal (1N1, 1N2)	Steel (3A1, 3A2)
Other metal (4N)	Plastics (1H1, 1H2)	
Plastics (4H1, 4H2)	Plywood (1D)	
Plywood (4D)	Steel (1A1, 1A2)	
Reconstituted wood (4F)		
Steel (4A)		

Packing Instructions 448 – 449

Cargo aircraft only

General requirements

Part 4, Chapter 1 requirements must be met, including:

1) Compatibility requirements

- Substances must be compatible with their packagings as required by 4;1.1.3.
- Metal packagings must be corrosion resistant or be protected against corrosion for substances with a Class 8 subsidiary risk.

2) Closure requirements

- Closures must meet the requirements of 4;1.1.4.

COMBINATION PACKAGINGS					SINGLE PACKAGINGS
<i>Packing instruction</i>	<i>Packing group</i>	<i>Inner packaging (see 6;3.2)</i>	<i>Inner packaging quantity (per receptacle)</i>	<i>Total quantity per package</i>	
—	I	Forbidden (only permitted for wetted explosives, see Packing Instruction 451)			
448	II	Glass	2.5 kg	50 kg	50 kg
		Plastics	5.0 kg		
		Metal	5.0 kg		
		Plastic bag	2.5 kg		
449	III	Glass	5.0 kg	100 kg	100 kg
		Plastics	10.0 kg		
		Metal	10.0 kg		
		Plastic bag	5.0 kg		

ADDITIONAL PACKING REQUIREMENTS FOR COMBINATION PACKAGINGS*Packing Group III*

— Packagings must meet the Packing Group II performance requirements.

OUTER PACKAGINGS OF COMBINATION PACKAGINGS (see 6;3.1)*Boxes*

Aluminium (4B)
 Fibreboard (4G)
 Natural wood (4C1, 4C2)
 Other metal (4N)
 Plastics (4H1, 4H2)
 Plywood (4D)
 Reconstituted wood (4F)
 Steel (4A)

Drums

Aluminium (1B1, 1B2)
 Fibre (1G)
 Other metal (1N1, 1N2)
 Plastics (1H1, 1H2)
 Plywood (1D)
 Steel (1A1, 1A2)

Jerricans

Aluminium (3B1, 3B2)
 Plastics (3H1, 3H2)
 Steel (3A1, 3A2)

ADDITIONAL PACKING REQUIREMENTS FOR SINGLE PACKAGINGS*Packing Group III*

- Packagings must meet the Packing Group II performance requirements.
- Fibre, fibreboard, wood and plywood single packagings must be fitted with a suitable liner.

SINGLE PACKAGINGS*Boxes*

Aluminium (4B)
 Fibreboard (4G)
 Natural wood (4C2)
 Other metal (4N)
 Plywood (4D)
 Plastics (4H2)
 Reconstituted wood (4F)
 Steel (4A)

Composites

All (see 6;3.1.18)

Cylinders

See 4;2.7

Drums

Aluminium (1B1, 1B2)
 Fibre (1G)
 Other metal (1N1, 1N2)
 Plastics (1H1, 1H2)
 Plywood (1D)
 Steel (1A1, 1A2)

Jerricans

Aluminium (3B1, 3B2)
 Plastics (3H1, 3H2)
 Steel (3A1, 3A2)

Packing Instruction 451

Passenger and cargo aircraft — wetted explosives (Packing Group I)

General requirements

Part 4, Chapter 1 requirements must be met, including:

1) Compatibility requirements

- Substances must be compatible with their packagings as required by 4;1.1.3.
- Metal packagings must be corrosion resistant or be protected against corrosion for substances with a Class 8 subsidiary risk.

2) Closure requirements

- Closures must meet the requirements of 4;1.1.4.

COMBINATION PACKAGINGS					SINGLE PACKAGINGS
UN number and proper shipping name	Inner packaging (see 6;3.2)	Inner packaging quantity (per receptacle)	Total quantity per package — passenger	Total quantity per package — cargo	
UN 1354 Trinitrobenzene, wetted UN 1355 Trinitrobenzoic acid, wetted UN 1356 Trinitrotoluene, wetted or TNT, wetted UN 3364 Picric acid, wetted or Trinitrophenol, wetted, with not less than 10% water, by mass UN 3365 Picryl chloride, wetted or Trinitrochlorobenzene, wetted UN 3366 Trinitrotoluene, wetted or TNT, wetted UN 3367 Trinitrobenzene, wetted UN 3368 Trinitrobenzoic acid, wetted UN 3369 Sodium dinitro-o-cresolate, wetted UN 3370 Urea nitrate, wetted	Glass Plastics Metal Plastic bag	0.5 kg	0.5 kg	0.5 kg	No
UN 1336 Nitroguanidine, wetted or Picrite, wetted UN 1337 Nitrostarch, wetted UN 1357 Urea nitrate, wetted	Glass Plastics Metal Plastic bag	0.5 kg	1 kg	15 kg	No
UN 1310 Ammonium picrate, wetted <i>See Note 1 below.</i>	Glass Plastics Metal Plastic bag	0.5 kg	0.5 kg	0.5 kg	No
UN 1349 Sodium picramate, wetted <i>See Note 1 below.</i>	Glass Plastics Metal Plastic bag	0.5 kg	Forbidden	15 kg	No
UN 1320 Dinitrophenol, wetted UN 1321 Dinitrophenolates, wetted UN 1322 Dinitroresorcinol, wetted UN 1344 Picric acid, wetted or Trinitrophenol, wetted, with not less than 30% water, by mass UN 1348 Sodium dinitro-o-cresolate, wetted UN 1517 Zirconium picramate, wetted UN 3317 2-Amino-4,6-dinitrophenol, wetted <i>See Note 1 below.</i>	Glass Plastics Metal Plastic bag	0.5 kg	1 kg	15 kg	No
UN 1571 Barium azide, wetted UN 2852 Dipicryl sulphide, wetted	Glass Plastics	0.25 kg	Forbidden	0.5 kg	No
UN 3474 1-Hydroxybenzotriazole, anhydrous, wetted	Glass Plastics	0.5 kg	0.5 kg	0.5 kg	No

Note 1.— These substances must be in lead free packagings.

ADDITIONAL PACKING REQUIREMENTS FOR COMBINATION PACKAGINGS

- Packagings must be designed and constructed to prevent the loss of water or alcohol content or the content of the phlegmatizer.
- Packagings must be so constructed and closed so as to avoid an explosive over pressure or pressure build-up of more than 300 kPa (3 bar).
- The type of packaging and maximum permitted quantity per packaging are limited by the provisions of Part 2;1.5.2 and may be less than the limits shown above.
- Plastic or glass inner packagings must be packed in tightly closed metal or rigid plastic receptacles before packing in outer packagings. Inner packagings must be packed with absorbent material in sufficient quantity to absorb the contents in the event of leakage.

OUTER PACKAGINGS OF COMBINATION PACKAGINGS (see 6;3.1)*Boxes*

Aluminium (4B)
 Fibreboard (4G)
 Natural wood (4C1, 4C2)
 Other metal (4N)
 Plastics (4H1, 4H2)
 Plywood (4D)
 Reconstituted wood (4F)
 Steel (4A)

Drums

Aluminium (1B2)
 Fibre (1G)
 Other metal (1N2)
 Plastics (1H1, 1H2)
 Plywood (1D)
 Steel (1A2)

Jerricans

Aluminium (3B2)
 Other metal (3N2)
 Plastics (3H1, 3H2)
 Steel (3A2)

Packing Instruction 452

Passenger aircraft for UN 2555, 2556 and 2557 only

General requirements

Part 4, Chapter 1 requirements must be met, including:

1) **Compatibility requirements**

- Substances must be compatible with their packagings as required by 4;1.1.3.

2) **Closure requirements**

- Closures must meet the requirements of 4;1.1.4.

COMBINATION PACKAGINGS				SINGLE PACKAGING S
<i>UN number and proper shipping name</i>	<i>Inner packaging (see 6;3.2)</i>	<i>Inner packaging quantity (per receptacle)</i>	<i>Total quantity per package</i>	
UN 2555 Nitrocellulose with water	Glass	1.0 kg	15 kg	No
	Plastics	1.0 kg		
	Metal	1.0 kg		
	Plastic bag	1.0 kg		
UN 2556 Nitrocellulose with alcohol	Glass	1.0 kg	1 kg	No
	Plastics	1.0 kg		
	Metal	1.0 kg		
	Plastic bag	1.0 kg		
UN 2557 Nitrocellulose, mixture without plasticizer, without pigment or Nitrocellulose, mixture without plasticizer, with pigment or Nitrocellulose, mixture with plasticizer, without pigment or Nitrocellulose, mixture with plasticizer, with pigment	Glass	1.0 kg	1 kg	No
	Plastics	1.0 kg		
	Metal	1.0 kg		
	Plastic bag	1.0 kg		

ADDITIONAL PACKING REQUIREMENTS FOR COMBINATION PACKAGINGS

- Packagings must be designed and constructed to prevent the loss of water or alcohol content or the content of the phlegmatizer.
- Packagings must be so constructed and closed so as to avoid an explosive over pressure or pressure build-up of more than 300 kPa (3 bar).

OUTER PACKAGINGS OF COMBINATION PACKAGINGS (see 6;3.1)

Boxes

Aluminium (4B)
Fibreboard (4G)
Natural wood (4C1, 4C2)
Other metal (4N)
Plastics (4H1, 4H2)
Plywood (4D)
Reconstituted wood (4F)
Steel (4A)

Drums

Aluminium (1B2)
Fibre (1G)
Other metal (1N2)
Plastics (1H1, 1H2)
Plywood (1D)

Jerricans

Aluminium (3B2)
Other metal (3N2)
Plastics (3H1, 3H2)
Steel (3A2)

Packing Instruction 453

Cargo aircraft only for UN 2555, 2556 and 2557 only

General requirements

Part 4, Chapter 1 requirements must be met, including:

1) Compatibility requirements

- Substances must be compatible with their packagings as required by 4;1.1.3.

2) Closure requirements

- Closures must meet the requirements of 4;1.1.4.

COMBINATION PACKAGINGS				SINGLE PACKAGINGS
UN number and proper shipping name	Inner packaging (see 6;3.2)	Inner packaging quantity (per receptacle)	Total quantity per package	
UN 2555 Nitrocellulose with water	Glass	1.0 kg	50 kg	50 kg
	Plastics	1.0 kg		
	Metal	1.0 kg		
	Plastic bag	1.0 kg		
UN 2556 Nitrocellulose with alcohol	Glass	1.0 kg	15 kg	15 kg
	Plastics	1.0 kg		
	Metal	1.0 kg		
	Plastic bag	1.0 kg		
UN 2557 Nitrocellulose mixture without plasticizer, without pigment or Nitrocellulose mixture without plasticizer, with pigment or Nitrocellulose mixture with plasticizer, without pigment or Nitrocellulose mixture with plasticizer, with pigment	Glass	1.0 kg	15 kg	15 kg
	Plastics	1.0 kg		
	Metal	1.0 kg		
	Plastic bag	1.0 kg		

ADDITIONAL PACKING REQUIREMENTS FOR COMBINATION PACKAGINGS

- Packagings must be designed and constructed to prevent the loss of water or alcohol content or the content of the phlegmatizer.
- Packagings must be so constructed and closed so as to avoid an explosive over pressure or pressure build-up of more than 300 kPa (3 bar).

OUTER PACKAGINGS OF COMBINATION PACKAGINGS (see 6;3.1)

Boxes

Aluminium (4B)
Fibreboard (4G)
Natural wood (4C1, 4C2)
Other metal (4N)
Plastics (4H1, 4H2)
Plywood (4D)
Reconstituted wood (4F)
Steel (4A)

Drums

Aluminium (1B2)
Fibre (1G)
Other metal (1N2)
Plastics (1H1, 1H2)
Plywood (1D)

Jerricans

Aluminium (3B2)
Other metal (3N2)
Plastics (3H1, 3H2)
Steel (3A2)

ADDITIONAL PACKING REQUIREMENTS FOR SINGLE PACKAGINGS

- Packagings must be designed and constructed to prevent the loss of water or alcohol content or the content of the phlegmatizer.
- Packagings must be so constructed and closed so as to avoid an explosive over pressure or pressure build-up of more than 300 kPa (3 bar).
- Fibre, fibreboard, wood and plywood single packagings must be fitted with a suitable liner.

SINGLE PACKAGINGS

<i>Boxes</i>	<i>Composites</i>	<i>Cylinders</i>	<i>Drums</i>	<i>Jerricans</i>
Aluminium (4B) Fibreboard (4G) Natural wood (4C1, 4C2) Plastics (4H2) Plywood (4D) Reconstituted wood (4F) Steel (4A)	All (see 6;3.1.18)	See 4;2.7	Aluminium (1B1, 1B2) Fibre (1G) Other metal (1N1, 1N2) Plastics (1H1, 1H2) Plywood (1D) Steel (1A1, 1A2)	Aluminium (3B1, 3B2) Plastics (3H1, 3H2) Steel (3A1, 3A2)

Packing Instruction 454

Passenger and cargo aircraft for UN 1324 only

General requirements

Part 4, Chapter 1 requirements must be met, including:

1) Compatibility requirements

- Substances must be compatible with their packagings as required by 4;1.1.3.

2) Closure requirements

- Closures must meet the requirements of 4;1.1.4.

COMBINATION PACKAGINGS			SINGLE PACKAGINGS
<i>UN number and proper shipping name</i>	<i>Total quantity per package — passenger</i>	<i>Total quantity per package — cargo</i>	
UN 1324 Films, nitrocellulose base	25 kg	100 kg	No

ADDITIONAL PACKING REQUIREMENTS FOR COMBINATION PACKAGINGS

- Packagings must meet the Packing Group II performance requirements.
- Each reel must be placed in a tightly closed metal can or strong cardboard or fibreboard inner packaging with cover held in place by adhesive tape or paper.

OUTER PACKAGINGS OF COMBINATION PACKAGINGS (see 6;3.1)

<i>Boxes</i>	<i>Drums</i>	<i>Jerricans</i>
Aluminium (4B) Fibreboard (4G)* Natural wood (4C1, 4C2) Other metal (4N) Plastics (4H1, 4H2)* Plywood (4D) Reconstituted wood (4F) Steel (4A)	Aluminium (1B1, 1B2) Fibre (1G)* Other metal (1N1, 1N2) Plastics (1H1, 1H2)* Plywood (1D) Steel (1A1, 1A2)	Aluminium (3B1, 3B2) Plastics (3H1, 3H2)* Steel (3A1, 3A2)

*These packagings are permitted only for a maximum of 600 m of film.

Packing Instruction Y454

Limited quantities
Passenger and cargo aircraft for UN 1324 only

General requirements

Part 4, Chapter 1 requirements must be met (except that 4;1.1.2, 1.1.9 c), 1.1.9 e), 1.1.16, 1.1.18 and 1.1.20 do not apply), including:

1) Compatibility requirements

- Substances must be compatible with their packagings as required by 4;1.1.3.

2) Closure requirements

- Closures must meet the requirements of 4;1.1.4.

3) Limited quantity requirements

- Part 3, Chapter 4 requirements must be met, including:
 - the capability of the package to pass a 1.2 m drop test; and
 - a 24-hour stacking test.

COMBINATION PACKAGINGS				SINGLE PACKAGINGS
<i>UN number and proper shipping name</i>	<i>Total quantity of film per inner packaging</i>	<i>Total quantity per package</i>	<i>Total gross mass per package</i>	
UN 1324 Films, nitrocellulose base	1 kg	10 kg	30 kg	No

ADDITIONAL PACKING REQUIREMENTS FOR COMBINATION PACKAGINGS

- Each reel must be placed in a tightly closed metal can or strong cardboard or fibreboard inner packaging with cover held in place by adhesive tape or paper.

OUTER PACKAGINGS OF COMBINATION PACKAGINGS (see 6;3.1)

Boxes

Aluminium
Fibreboard*
Natural wood
Other metal
Plywood
Reconstituted wood
Solid plastic*
Steel

Drums

Aluminium
Fibre*
Other metal
Plastics*
Steel

Jerricans

Aluminium
Plastics*
Steel

*These packagings are permitted only for a maximum of 600 m or 1 kg (whichever is more restrictive) of film in one outer packaging.

Packing Instruction 455

Passenger and cargo aircraft for UN 1944 and 1945 only

General requirements

Part 4, Chapter 1 requirements must be met, including:

1) **Compatibility requirements**

- Substances must be compatible with their packagings as required by 4;1.1.3.

2) **Closure requirements**

- Closures must meet the requirements of 4;1.1.4.

COMBINATION PACKAGINGS				SINGLE PACKAGINGS
<i>UN number and proper shipping name</i>	<i>Packing conditions</i>	<i>Total quantity per package — passenger</i>	<i>Total quantity per package — cargo</i>	
UN 1944 Matches, safety UN 1945 Matches, wax 'vesta'	Packaging as set out in the list of outer packagings below may be used. For a maximum of 50 books The following packaging is permitted: Strong fibreboard carton, which is made of straw board covered with kraft paper, having a securely glued inside lining consisting of aluminium foil, at least 0.01 mm thick, the carton to have a full depth lid with all joints secured with gummed paper tape.	25 kg	100 kg	No

ADDITIONAL PACKING REQUIREMENTS FOR COMBINATION PACKAGINGS

- Matches, safety (book card or strike on box) must be of a type that will not ignite spontaneously under normal conditions of air transport and can be readily ignited by friction only by striking on the manufacturer's box, book or card.
- Matches must be tightly packed to prevent movement within the package and ignition by rubbing against an adjoining box, book or card.
- Matches must be securely wrapped in paper or foil or packed in tightly closed inner packagings.
- No more than 50 books of matches may be packed in one inner packaging.
- Packagings must meet the Packing Group II performance requirements.

OUTER PACKAGINGS OF COMBINATION PACKAGINGS (see 6;3.1)

Boxes

Aluminium (4B)
Fibreboard (4G)
Natural wood (4C1, 4C2)
Other metal (4N)
Plastics (4H1, 4H2)
Plywood (4D)
Reconstituted wood (4F)
Steel (4A)

Drums

Aluminium (1B1, 1B2)
Fibre (1G)
Other metal (1N1, 1N2)
Plastics (1H1, 1H2)
Steel (1A1, 1A2)

Jerricans

Aluminium (3B1, 3B2)
Plastics (3H1, 3H2)
Steel (3A1, 3A2)

Packing Instruction Y455

Limited quantities
Passenger and cargo aircraft for UN 1944 and 1945 only

General requirements

Part 4, Chapter 1 requirements must be met (except that 4;1.1.2, 1.1.9 c), 1.1.9 e), 1.1.16, 1.1.18 and 1.1.20 do not apply), including:

1) Compatibility requirements

- Substances must be compatible with their packagings as required by 4;1.1.3.

2) Closure requirements

- Closures must meet the requirements of 4;1.1.4.

3) Limited quantity requirements

- Part 3, Chapter 4 requirements must be met, including:
 - the capability of the package to pass a 1.2 m drop test; and
 - a 24-hour stacking test.

COMBINATION PACKAGINGS				SINGLE PACKAGINGS
<i>UN number and proper shipping name</i>	<i>Packing conditions</i>	<i>Total quantity per package</i>	<i>Total gross mass per package</i>	
UN 1944 Matches, safety UN 1945 Matches, wax 'vesta'	Packaging as set out in the list of outer packagings below may be used. For a maximum of 50 books The following packaging is permitted: Strong fibreboard carton, which is made of straw board covered with kraft paper, having a securely glued inside lining consisting of aluminium foil, at least 0.01 mm thick, the carton to have a full depth lid with all joints secured with gummed paper tape.	10 kg	30 kg	No

ADDITIONAL PACKING REQUIREMENTS FOR COMBINATION PACKAGINGS

- Matches, safety (book card or strike on box) must be of a type that will not ignite spontaneously under normal conditions of air transport and can be readily ignited by friction only by striking on the manufacturer's box, book or card.
- Matches must be tightly packed to prevent movement within the package and ignition by rubbing against an adjoining box, book or card.
- Matches must be securely wrapped in paper or foil or packed in tightly closed inner packagings.
- No more than 50 books of matches may be packed in one inner packaging.

OUTER PACKAGINGS OF COMBINATION PACKAGINGS (see 6;3.1)

Boxes

Aluminium
Fibreboard
Natural wood
Other metal
Plastics
Plywood
Reconstituted wood
Steel

Drums

Aluminium
Fibre
Other metal
Plastics
Steel

Jerricans

Aluminium
Plastics
Steel

Packing Instruction 456

Passenger and cargo aircraft for UN 2000 only

General requirements

Part 4, Chapter 1 requirements must be met.

<i>UN number and proper shipping name</i>	<i>Total quantity per package — passenger</i>	<i>Total quantity per package — cargo</i>
UN 2000 Celluloid	25 kg	100 kg

Packing Instruction 457

Passenger and cargo aircraft for UN 3241 only

General requirements

Part 4, Chapter 1 requirements must be met, including:

1) Compatibility requirements

- Substances must be compatible with their packagings as required by 4;1.1.3.

2) Closure requirements

- Closures must meet the requirements of 4;1.1.4.

COMBINATION PACKAGINGS					SINGLE PACKAGINGS	
<i>UN number and proper shipping name</i>	<i>Inner packaging (see 6;3.2)</i>	<i>Inner packaging quantity (per receptacle)</i>	<i>Total quantity per package — passenger</i>	<i>Total quantity per package — cargo</i>	<i>Passenger</i>	<i>Cargo</i>
UN 3241 2-Bromo-2-nitropropane-1,3-diol	Glass	0.5 kg	25 kg	50 kg	25 kg	50 kg
	Plastics	1.0 kg				
	Plastic bag	1.0 kg				

ADDITIONAL PACKING REQUIREMENTS FOR COMBINATION PACKAGINGS

- Packagings must meet the Packing Group II performance requirements.

OUTER PACKAGINGS OF COMBINATION PACKAGINGS (see 6;3.1)

<i>Boxes</i>	<i>Drums</i>	<i>Jerricans</i>
> Fibreboard (4G) Natural wood (4C1, 4C2)	> Fibre (1G) Plastics (1H1, 1H2) Plywood (1D)	> Plastics (3H1, 3H2)
> Plastics (4H1, 4H2) Plywood (4D) Reconstituted wood (4F)	>	
>		

ADDITIONAL PACKING REQUIREMENTS FOR SINGLE PACKAGINGS

- Packagings must meet the Packing Group II performance requirements.

SINGLE PACKAGINGS

	<i>Composites</i>	<i>Drums</i>	<i>Jerricans</i>
≠	Plastic receptacle with outer wooden box (6HC)	>	>
+	Plastic receptacle with outer plywood drum (6HD1)	>	>
+	Plastic receptacle with outer plywood box (6HD2)		
+	Plastic receptacle with outer fibre drum (6HG1)		
+	Plastic receptacle with outer fibreboard box (6HG2)		
+	Plastic receptacle with outer plastic drum (6HH1)		
		Plastics (1H1, 1H2)	Plastics (3H1, 3H2)

Packing Instruction Y457

Limited quantities
Passenger and cargo aircraft for UN 3241 only

General requirements

Part 4, Chapter 1 requirements must be met (except that 4;1.1.2, 1.1.9 c), 1.1.9 e), 1.1.16, 1.1.18 and 1.1.20 do not apply), including:

1) Compatibility requirements

- Substances must be compatible with their packagings as required by 4;1.1.3.

2) Closure requirements

- Closures must meet the requirements of 4;1.1.4.

3) Limited quantity requirements

- Part 3, Chapter 4 requirements must be met, including:
 - the capability of the package to pass a 1.2 m drop test; and
 - a 24-hour stacking test.

COMBINATION PACKAGINGS					SINGLE PACKAGINGS
<i>UN number and proper shipping name</i>	<i>Inner packaging (see 6;3.2)</i>	<i>Inner packaging quantity (per receptacle)</i>	<i>Total quantity per package</i>	<i>Total gross mass per package</i>	
UN 3241 2-Bromo-2-nitropropane-1,3-diol	Glass	0.5 kg	10 kg	30 kg	No
	Plastics	0.5 kg			
	Plastic bag	0.5 kg			

OUTER PACKAGINGS OF COMBINATION PACKAGINGS (see 6;3.1)

<i>Boxes</i>	<i>Drums</i>	<i>Jerricans</i>
>	>	>
Fibreboard	Fibre	Plastics
Natural wood	>	>
>	Plastics	
Plastics	>	
Plywood		
Reconstituted wood		
>		

Packing Instruction 458

Passenger and cargo aircraft for UN 3270 only

General requirements

Part 4, Chapter 1 requirements must be met, including:

1) Compatibility requirements

- Substances must be compatible with their packagings as required by 4;1.1.3.

2) Closure requirements

- Closures must meet the requirements of 4;1.1.4.

COMBINATION PACKAGINGS				SINGLE PACKAGINGS
<i>UN number and proper shipping name</i>	<i>Packing conditions</i>	<i>Total quantity per package — passenger</i>	<i>Total quantity per package — cargo</i>	
UN 3270 Nitrocellulose membrane filters	Any packaging from the list of outer packagings below provided that explosion is not possible by reason of increased internal pressure.	1 kg	15 kg	No

ADDITIONAL PACKING REQUIREMENTS FOR COMBINATION PACKAGINGS

- Packagings must meet the Packing Group II performance requirements.

OUTER PACKAGINGS OF COMBINATION PACKAGINGS (see 6;3.1)

<i>Boxes</i>	<i>Drums</i>	<i>Jerricans</i>
Aluminium (4B)	Aluminium (1B2)	Aluminium (3B2)
Fibreboard (4G)	Fibre (1G)	Plastics (3H2)
Natural wood (4C1, 4C2)	Other metal (1N2)	Steel (3A2)
Other metal (4N)	Plastics (1H2)	
Plastics (4H1, 4H2)	Steel (1A2)	
Plywood (4D)		
Reconstituted wood (4F)		
Steel (4A)		

Packing Instruction Y458

Limited quantities
Passenger and cargo aircraft for UN 3270 only

General requirements

Part 4, Chapter 1 requirements must be met (except that 4;1.1.2, 1.1.9 c), 1.1.9 e), 1.1.16, 1.1.18 and 1.1.20 do not apply), including:

1) Compatibility requirements

- Substances must be compatible with their packagings as required by 4;1.1.3.

2) Closure requirements

- Closures must meet the requirements of 4;1.1.4.

3) Limited quantity requirements

- Part 3, Chapter 4 requirements must be met, including:
 - the capability of the package to pass a 1.2 m drop test; and
 - a 24-hour stacking test.

COMBINATION PACKAGINGS				SINGLE PACKAGINGS
<i>UN number and proper shipping name</i>	<i>Packing conditions</i>	<i>Total quantity per package</i>	<i>Total gross mass per package</i>	
UN 3270 Nitrocellulose membrane filters	Any packaging from the list of outer packagings below provided that explosion is not possible by reason of increased internal pressure.	1 kg	30 kg	No

OUTER PACKAGINGS OF COMBINATION PACKAGINGS (see 6;3.1)

Boxes

Aluminium
Fibreboard
Natural wood
Other metal
Plastics
Plywood
Reconstituted wood
Steel

Drums

Aluminium
Fibre
Other metal
Plastics
Steel

Jerricans

Aluminium
Plastics
Steel

Packing Instruction 459

Passenger and cargo aircraft — self-reactive substances

General requirements

Part 4, Chapter 1 requirements must be met, including:

1) Compatibility requirements

- Substances must be compatible with their packagings as required by 4;1.1.3.

2) Closure requirements

- Closures must meet the requirements of 4;1.1.4.

COMBINATION PACKAGINGS							SINGLE PACKAGINGS
<i>UN number and proper shipping name</i>	<i>Inner packaging (see 6;3.2)</i>	<i>Inner packaging quantity (per receptacle) — passenger</i>	<i>Total quantity per package — passenger</i>	<i>Inner packaging quantity (per receptacle) — cargo</i>	<i>Total quantity per package — cargo</i>		
Liquids							
UN 3223	Self-reactive liquid type C	Plastics	0.5 L	5 L	1.0 L	10 L	No
UN 3225	Self-reactive liquid type D	Plastics	0.5 L	5 L	1.0 L	10 L	
UN 3227	Self-reactive liquid type E	Plastics	1.0 L	10 L	2.5 L	25 L	
UN 3229	Self-reactive liquid type F	Plastics	1.0 L	10 L	2.5 L	25 L	
Solids							
UN 3224	Self-reactive solid type C	Plastics	0.5 kg	5 kg	1.0 kg	10 kg	No
		Plastic bag	0.5 kg	5 kg	1.0 kg	10 kg	
UN 3226	Self-reactive solid type D	Plastics	0.5 kg	5 kg	1.0 kg	10 kg	
		Plastic bag	0.5 kg	5 kg	1.0 kg	10 kg	
UN 3228	Self-reactive solid type E	Plastics	1.0 kg	10 kg	2.5 kg	25 kg	
		Plastic bag	1.0 kg	10 kg	2.5 kg	25 kg	
UN 3230	Self-reactive solid type F	Plastics	1.0 kg	10 kg	2.5 kg	25 kg	
		Plastic bag	1.0 kg	10 kg	2.5 kg	25 kg	

ADDITIONAL PACKING REQUIREMENTS FOR COMBINATION PACKAGINGS

- Cushioning materials must not be readily combustible.
- Packagings must meet the Packing Group II performance requirements.

OUTER PACKAGINGS OF COMBINATION PACKAGINGS (see 6;3.1)

Boxes

Fibreboard (4G)
Natural wood (4C1, 4C2)
Plastics (4H1, 4H2)
Plywood (4D)
Reconstituted wood (4F)

Drums

Fibre (1G)
Plastics (1H1, 1H2)
Plywood (1D)

Jerricans

Plastics (3H1, 3H2)

Packing Instruction 462 – 463

Passenger aircraft

General requirements

Part 4, Chapter 1 requirements must be met, including:

1) Compatibility requirements

- Substances must be compatible with their packagings as required by 4;1.1.3.
- Metal packagings must be corrosion resistant or be protected against corrosion for substances with a Class 8 subsidiary risk.

2) Closure requirements

- Closures must meet the requirements of 4;1.1.4.

COMBINATION PACKAGINGS					SINGLE PACKAGINGS
Packing instruction	Packing group	Inner packaging (see 6;3.2)	Inner packaging quantity (per receptacle)	Total quantity per package	
—	I	Forbidden			
462	II	Glass	1.0 L	1 L	No
		Plastics	1.0 L		
		Metal	1.0 L		
463	III	Glass	2.5 L	5 L	5 L
		Plastics	2.5 L		
		Metal	5.0 L		

ADDITIONAL PACKING REQUIREMENTS FOR COMBINATION PACKAGINGS

Packing Group III

- Packagings must meet the Packing Group II performance requirements.

OUTER PACKAGINGS OF COMBINATION PACKAGINGS (see 6;3.1)

Boxes

Aluminium (4B)
Fibreboard (4G)
Natural wood (4C1, 4C2)
Other metal (4N)
Plastics (4H1, 4H2)
Plywood (4D)
Reconstituted wood (4F)
Steel (4A)

Drums

Aluminium (1B1, 1B2)
Fibre (1G)
Other metal (1N1, 1N2)
Plastics (1H1, 1H2)
Plywood (1D)
Steel (1A1, 1A2)

Jerricans

Aluminium (3B1, 3B2)
Plastics (3H1, 3H2)
Steel (3A1, 3A2)

ADDITIONAL PACKING REQUIREMENTS FOR SINGLE PACKAGINGS

Packing Group III

- Packagings must meet the Packing Group II performance requirements.

SINGLE PACKAGINGS FOR PACKING GROUP III ONLY (PI 463)

Composites

All (see 6;3.1.18)

Cylinders

See 4;2.7

Drums

Aluminium (1B1)
Other metal (1N1)
Plastics (1H1)
Steel (1A1)

Jerricans

Aluminium (3B1)
Plastics (3H1)
Steel (3A1)

Packing Instruction 464 – 465

Cargo aircraft only

General requirements

Part 4, Chapter 1 requirements must be met, including:

1) Compatibility requirements

- Substances must be compatible with their packagings as required by 4;1.1.3.
- Metal packagings must be corrosion resistant or be protected against corrosion for substances with a Class 8 subsidiary risk.

2) Closure requirements

- Closures must meet the requirements of 4;1.1.4.

COMBINATION PACKAGINGS					SINGLE PACKAGINGS
Packing instruction	Packing group	Inner packaging (see 6;3.2)	Inner packaging quantity (per receptacle)	Total quantity per package	
—	I	Forbidden			
464	II	Glass	2.5 L	5 L	No
		Plastics	2.5 L		
		Metal	5.0 L		
465	III	Glass	5.0 L	60 L	60 L
		Plastics	5.0 L		
		Metal	10.0 L		

ADDITIONAL PACKING REQUIREMENTS FOR COMBINATION PACKAGINGS

Packing Group III

- Packagings must meet the Packing Group II performance requirements.

OUTER PACKAGINGS OF COMBINATION PACKAGINGS (see 6;3.1)

Boxes

Aluminium (4B)
Fibreboard (4G)
Natural wood (4C1, 4C2)
Other metal (4N)
Plastics (4H1, 4H2)
Plywood (4D)
Reconstituted wood (4F)
Steel (4A)

Drums

Aluminium (1B1, 1B2)
Fibre (1G)
Other metal (1N1, 1N2)
Plastics (1H1, 1H2)
Plywood (1D)
Steel (1A1, 1A2)

Jerricans

Aluminium (3B1, 3B2)
Plastics (3H1, 3H2)
Steel (3A1, 3A2)

ADDITIONAL PACKING REQUIREMENTS FOR SINGLE PACKAGINGS

Packing Group III

- Packagings must meet the Packing Group II performance requirements.

SINGLE PACKAGINGS FOR PACKING GROUP III ONLY (PI 465)

Composites

All (see 6;3.1.18)

Cylinders

See 4;2.7

Drums

Aluminium (1B1)
Other metal (1N1)
Plastics (1H1)
Steel (1A1)

Jerricans

Aluminium (3B1)
Plastics (3H1)
Steel (3A1)

Packing Instruction 466 – 469

Passenger aircraft

General requirements

Part 4, Chapter 1 requirements must be met, including:

1) Compatibility requirements

- Substances must be compatible with their packagings as required by 4;1.1.3.
- Metal packagings must be corrosion resistant or be protected against corrosion for substances with a Class 8 subsidiary risk.

2) Closure requirements

- Closures must meet the requirements of 4;1.1.4.

COMBINATION PACKAGINGS					SINGLE PACKAGINGS
Packing instruction	Packing group	Inner packaging (see 6;3.2)	Inner packaging quantity (per receptacle)	Total quantity per package	
—	I	Forbidden			
466	II	Glass	1.0 kg	15 kg	No
		Plastics	1.0 kg		
		Metal	1.0 kg		
467	II	Glass	1.0 kg	15 kg	No
		Plastics	2.5 kg		
		Metal	2.5 kg		
		Plastic bag	1.0 kg		
468	III	Glass	2.5 kg	25 kg	No
		Plastics	2.5 kg		
		Metal	5.0 kg		
469	III	Glass	5.0 kg	25 kg	No
		Plastics	10.0 kg		
		Metal	10.0 kg		
		Plastic bag	5.0 kg		

ADDITIONAL PACKING REQUIREMENTS FOR COMBINATION PACKAGINGS

Packing Group III

- Packagings must meet the Packing Group II performance requirements.

OUTER PACKAGINGS OF COMBINATION PACKAGINGS (see 6;3.1)

Boxes

Aluminium (4B)
Fibreboard (4G)
Natural wood (4C1, 4C2)
Other metal (4N)
Plastics (4H1, 4H2)
Plywood (4D)
Reconstituted wood (4F)
Steel (4A)

Drums

Aluminium (1B1, 1B2)
Fibre (1G)
Other metal (1N1, 1N2)
Plastics (1H1, 1H2)
Plywood (1D)
Steel (1A1, 1A2)

Jerricans

Aluminium (3B1, 3B2)
Plastics (3H1, 3H2)
Steel (3A1, 3A2)

Packing Instruction 470 – 471

Cargo aircraft only

General requirements

Part 4, Chapter 1 requirements must be met, including:

1) Compatibility requirements

- Substances must be compatible with their packagings as required by 4;1.1.3.
- Metal packagings must be corrosion resistant or be protected against corrosion for substances with a Class 8 subsidiary risk.

2) Closure requirements

- Closures must meet the requirements of 4;1.1.4.

COMBINATION PACKAGINGS					SINGLE PACKAGINGS
Packing instruction	Packing group	Inner packaging (see 6;3.2)	Inner packaging quantity (per receptacle)	Total quantity per package	
—	I	Forbidden			
470	II	Glass	2.5 kg	50 kg	50 kg
		Plastics	5.0 kg		
		Metal	5.0 kg		
		Plastic bag	2.5 kg		
471	III	Glass	5.0 kg	100 kg	100 kg
		Plastics	10.0 kg		
		Metal	10.0 kg		
		Plastic bag	5.0 kg		

ADDITIONAL PACKING REQUIREMENTS FOR COMBINATION PACKAGINGS

Packing Group III

- Packagings must meet the Packing Group II performance requirements.

OUTER PACKAGINGS OF COMBINATION PACKAGINGS (see 6;3.1)

Boxes

Aluminium (4B)
Fibreboard (4G)
Natural wood (4C1, 4C2)
Other metal (4N)
Plastics (4H1, 4H2)
Plywood (4D)
Reconstituted wood (4F)
Steel (4A)

Drums

Aluminium (1B1, 1B2)
Fibre (1G)
Other metal (1N1, 1N2)
Plastics (1H1, 1H2)
Plywood (1D)
Steel (1A1, 1A2)

Jerricans

Aluminium (3B1, 3B2)
Plastics (3H1, 3H2)
Steel (3A1, 3A2)

ADDITIONAL PACKING REQUIREMENTS FOR SINGLE PACKAGINGS

Packing Group III

- Packagings must meet the Packing Group II performance requirements.
- Fibreboard, wood and plywood single packagings must be fitted with a suitable liner.

SINGLE PACKAGINGS

<i>Boxes</i>	<i>Composites</i>	<i>Cylinders</i>	<i>Drums</i>	<i>Jerricans</i>
Aluminium (4B) Fibreboard (4G) Natural wood (4C2) Other metal (4N) Plastics (4H2) Plywood (4D) Reconstituted wood (4F) Steel (4A)	All (see 6;3.1.18)	See 4;2.7	Aluminium (1B1, 1B2) Other metal (1N1, 1N2) Plastics (1H1, 1H2) Steel (1A1, 1A2)	Aluminium (3B1, 3B2) Plastics (3H1, 3H2) Steel (3A1, 3A2)

Packing Instruction 472

Passenger and cargo aircraft for UN 1362 only

General requirements

Part 4, Chapter 1 requirements must be met, including:

1) **Compatibility requirements**

— Substances must be compatible with their packagings as required by 4;1.1.3.

2) **Closure requirements**

— Closures must meet the requirements of 4;1.1.4.

COMBINATION PACKAGINGS				SINGLE PACKAGINGS
<i>UN number and proper shipping name</i>	<i>Inner packaging (see 6;3.2)</i>	<i>Inner packaging quantity (per receptacle)</i>	<i>Total quantity per package</i>	
UN 1362 Carbon, activated	Plastics	0.1 kg	0.5 kg	No

OUTER PACKAGINGS OF COMBINATION PACKAGINGS (see 6;3.1)

<i>Boxes</i>	<i>Drums</i>	<i>Jerricans</i>
Aluminium (4B) Steel (4A)	Aluminium (1B1, 1B2) Steel (1A1, 1A2)	Aluminium (3B1, 3B2) Steel (3A1, 3A2)

Packing Instruction 473

Passenger and cargo aircraft — for UN 1378 and UN 2881 only

General requirements

Part 4, Chapter 1 requirements must be met, including:

- 1) Compatibility requirements
 - Substances must be compatible with their packagings as required by 4;1.1.3.
- 2) Closure requirements
 - Closures must meet the requirements of 4;1.1.4.

COMBINATION PACKAGINGS							SINGLE PACKAGINGS	
UN number and proper shipping name	Packing group	Inner packaging (see 6;3.2)	Inner packaging quantity (per receptacle) — passenger	Total quantity per package — passenger	Inner packaging quantity (per receptacle) — cargo	Total quantity per package — cargo	Passenger	Cargo
UN 1378 Metal catalyst, wetted	II	Glass	Forbidden		1.0 kg	50 kg	No	No
		Metal			1.0 kg			
UN 2881 Metal catalyst, dry	I	Forbidden		Forbidden		No	No	
								II
	Metal	1.0 kg						
	III	Glass	1.0 kg	25 kg	2.5 kg	100 kg	No	100 kg
Metal		1.0 kg	25 kg	5.0 kg	100 kg			

ADDITIONAL PACKING REQUIREMENTS FOR COMBINATION PACKAGINGS

Packing Group III

- Packagings must meet the Packing Group II performance requirements.

OUTER PACKAGINGS OF COMBINATION PACKAGINGS (see 6;3.1)

Boxes

Aluminium (4B)
Fibreboard (4G)
Natural wood (4C1, 4C2)
Other metal (4N)
Plastics (4H1, 4H2)
Plywood (4D)
Reconstituted wood (4F)
Steel (4A)

Drums

Aluminium (1B1, 1B2)
Fibre (1G)
Other metal (1N1, 1N2)
Plastics (1H1, 1H2)
Steel (1A1, 1A2)

Jerricans

Aluminium (3B1, 3B2)
Plastics (3H1, 3H2)
Steel (3A1, 3A2)

ADDITIONAL PACKING REQUIREMENTS FOR SINGLE PACKAGINGS

Packing Group III

- Packagings must meet the Packing Group II performance requirements.

SINGLE PACKAGINGS FOR PACKING GROUP III ONLY

+	Cylinders	<i>Drums</i>	<i>Jerricans</i>
+	See 4;2.7	Steel (1A1, 1A2)	Steel (3A1, 3A2)

Packing Instructions Y474 – Y477

Limited quantities
Passenger and cargo aircraft

General requirements

Part 4, Chapter 1 requirements must be met (except that 4;1.1.2, 1.1.9 c), 1.1.9 e), 1.1.16, 1.1.18 and 1.1.20 do not apply), including:

1) Compatibility requirements

- Substances must be compatible with their packagings as required by 4;1.1.3.
- Metal packagings must be corrosion resistant or be protected against corrosion.

2) Closure requirements

- Closures must meet the requirements of 4;1.1.4.

3) Limited quantity requirements

- Part 3, Chapter 4 requirements must be met, including:
 - the capability of the package to pass a 1.2 m drop test; and
 - a 24-hour stacking test.

COMBINATION PACKAGINGS						SINGLE PACKAGINGS	
<i>Packing instruction</i>	<i>Packing group</i>	<i>Inner packaging (see 6;3.2)</i>	<i>Inner packaging quantity (per receptacle)</i>	<i>Total quantity per package</i>	<i>Total gross mass per package</i>		
Y474	II	Glass	0.5 kg	1 kg	30 kg	No	
		Plastics	0.5 kg				
		Metal	0.5 kg				
		Plastic bag	0.5 kg				
Y475	II	Glass	0.5 kg	5 kg		30 kg	No
		Plastics	0.5 kg				
		Metal	0.5 kg				
		Plastic bag	0.5 kg				
Y476	III	Glass	1.0 kg	5 kg		30 kg	No
		Plastics	1.0 kg				
		Metal	1.0 kg				
		Plastic bag	1.0 kg				
Y477	III	Glass	1.0 kg	10 kg		30 kg	No
		Plastics	1.0 kg				
		Metal	1.0 kg				
		Plastic bag	1.0 kg				

ADDITIONAL PACKING REQUIREMENTS FOR COMBINATION PACKAGINGS

Packing Groups II and III

- For wetted substances where the outer packaging is not leakproof, a leakproof liner or equally effective means of intermediate containment must be provided.

OUTER PACKAGINGS OF COMBINATION PACKAGINGS (see 6;3.1)

<i>Boxes</i>	<i>Drums</i>	<i>Jerricans</i>
Aluminium	Aluminium	Aluminium
Fibreboard	Fibre	Plastics
Natural wood	Other metal	Steel
Other metal	Plastics	
Plastics	Steel	
Plywood		
Reconstituted wood		
Steel		

Packing Instructions 478 – 479

Passenger aircraft

General requirements

Part 4, Chapter 1 requirements must be met, including:

1) Compatibility requirements

- Substances must be compatible with their packagings as required by 4;1.1.3.
- Metal packagings must be corrosion resistant or be protected against corrosion for substances with a Class 8 subsidiary risk.

2) Closure requirements

- Closures must meet the requirements of 4;1.1.4.

COMBINATION PACKAGINGS					SINGLE PACKAGINGS
<i>Packing instruction</i>	<i>Packing group</i>	<i>Inner packaging (see 6;3.2)</i>	<i>Inner packaging quantity (per receptacle)</i>	<i>Total quantity per package</i>	
—	I	Forbidden			
478	II	Glass	1.0 L	1 L	No
		Plastics	1.0 L		
		Metal	1.0 L		
479	III	Glass	2.5 L	5 L	5 L
		Plastics	2.5 L		
		Metal	5.0 L		

ADDITIONAL PACKING REQUIREMENTS FOR COMBINATION PACKAGINGS*Packing Group II*

- Inner packagings must have threaded enclosures and must be surrounded in inert cushioning and absorbent material in a quantity sufficient to absorb the entire contents and enclosed in a leakproof liner, plastic bag or other equally effective means of intermediate leakproof containment.

Packing Group III

- Packagings must meet the Packing Group II performance requirements.

OUTER PACKAGINGS OF COMBINATION PACKAGINGS (see 6;3.1)*Boxes*

Aluminium (4B)
 Fibreboard (4G)
 Natural wood (4C1, 4C2)
 Other metal (4N)
 Plastics (4H1, 4H2)
 Plywood (4D)
 Reconstituted wood (4F)
 Steel (4A)

Drums

Aluminium (1B1, 1B2)
 Fibre (1G)
 Other metal (1N1, 1N2)
 Plastics (1H1, 1H2)
 Plywood (1D)
 Steel (1A1, 1A2)

Jerricans

Aluminium (3B1, 3B2)
 Plastics (3H1, 3H2)
 Steel (3A1, 3A2)

ADDITIONAL PACKING REQUIREMENTS FOR SINGLE PACKAGINGS*Packing Group III*

— Packagings must meet the Packing Group II performance requirements.

SINGLE PACKAGINGS FOR PACKING GROUP III (PI 479 only)*Composites*

All (see 6;3.1.18)

Cylinders

See 4;2.7

Drums

Aluminium (1B1)
 Other metal (1N1)
 Plastics (1H1)
 Steel (1A1)

Jerricans

Aluminium (3B1)
 Plastics (3H1)
 Steel (3A1)

Packing Instructions 480 – 482

Cargo aircraft only

General requirements

Part 4, Chapter 1 requirements must be met, including:

1) Compatibility requirements

- Substances must be compatible with their packagings as required by 4;1.1.3.
- Metal packagings must be corrosion resistant or be protected against corrosion for substances with a Class 8 subsidiary risk.

2) Closure requirements

- Closures must meet the requirements of 4;1.1.4.

COMBINATION PACKAGINGS					SINGLE PACKAGINGS
Packing instruction	Packing group	Inner packaging (see 6;3.2)	Inner packaging quantity (per receptacle)	Total quantity per package	
480	I	Glass	1.0 L	1 L	No
		Plastics	Forbidden		
		Metal	1.0 L		
481	II	Glass	2.5 L	5 L	No
		Plastics	2.5 L		
		Metal	5.0 L		
482	III	Glass	5.0 L	60 L	60 L
		Plastics	5.0 L		
		Metal	10.0 L		

ADDITIONAL PACKING REQUIREMENTS FOR COMBINATION PACKAGINGS*Packing Group I*

- Inner packagings must have threaded enclosures and must be surrounded in inert cushioning and absorbent material in a quantity sufficient to absorb the entire contents and enclosed in a leakproof liner, plastic bag or other equally effective means of intermediate leakproof containment.

Packing Group II

- Inner packagings must have threaded enclosures and must be surrounded in inert cushioning and absorbent material in a quantity sufficient to absorb the entire contents.

Packing Group III

- Packagings must meet the Packing Group II performance requirements.

OUTER PACKAGINGS OF COMBINATION PACKAGINGS (see 6;3.1)*Boxes*

Aluminium (4B)
Fibreboard (4G)
Natural wood (4C1, 4C2)
Other metal (4N)
Plastics (4H1, 4H2)
Plywood (4D)
Reconstituted wood (4F)
Steel (4A)

Drums

Aluminium (1B1, 1B2)
Fibre (1G)
Other metal (1N1, 1N2)
Plastics (1H1, 1H2)
Plywood (1D)
Steel (1A1, 1A2)

Jerricans

Aluminium (3B1, 3B2)
Plastics (3H1, 3H2)
Steel (3A1, 3A2)

ADDITIONAL PACKING REQUIREMENTS FOR SINGLE PACKAGINGS*Packing Group III*

- Packagings must meet the Packing Group II performance requirements.

SINGLE PACKAGINGS FOR PACKING GROUPS I AND II

Cylinders, provided that the general provisions of 4;2.7 are met. Cylinders must be made of steel and subjected to an initial test and period tests every ten years at a pressure of not less than 0.6 Mpa (6 bar) (gauge pressure). During transport, the liquid must be under a layer of inert gas with a gauge pressure of not less than 20 kPa (0.2 bar).

SINGLE PACKAGINGS FOR PACKING GROUP III ONLY (PI 482)*Composites*

All (see 6;3.1.18)

Cylinders

See 4;2.7

Drums

Aluminium (1B1)
Other metal (1N1)
Plastics (1H1)
Steel (1A1)

Jerricans

Aluminium (3B1)
Plastics (3H1)
Steel (3A1)

Packing Instructions 483 – 486

Passenger aircraft

General requirements

Part 4, Chapter 1 requirements must be met, including:

1) Compatibility requirements

- Substances must be compatible with their packagings as required by 4;1.1.3.
- Metal packagings must be corrosion resistant or be protected against corrosion for substances with a Class 8 subsidiary risk.

2) Closure requirements

- Closures must meet the requirements of 4;1.1.4.

COMBINATION PACKAGINGS					SINGLE PACKAGINGS
<i>Packing instruction</i>	<i>Packing group</i>	<i>Inner packaging (see 6;3.2)</i>	<i>Inner packaging quantity (per receptacle)</i>	<i>Total quantity per package</i>	
—	I	Forbidden			
483	II	Glass	1.0 kg	15 kg	No
		Plastics	1.0 kg		
		Metal	1.0 kg		
484	II	Glass	1.0 kg	15 kg	No
		Plastics	2.5 kg		
		Metal	2.5 kg		
		Plastic bag	1.0 kg		
485	III	Glass	2.5 kg	25 kg	No
		Plastics	2.5 kg		
		Metal	5.0 kg		
486	III	Glass	5.0 kg	25 kg	No
		Plastics	10.0 kg		
		Metal	10.0 kg		
		Plastic bag	5.0 kg		

ADDITIONAL PACKING REQUIREMENTS FOR COMBINATION PACKAGINGS

Packing Group III

- Packagings must meet the Packing Group II performance requirements.
- For wetted substances where the outer packaging is not leakproof, a leakproof liner or equally effective means of intermediate containment must be provided.

OUTER PACKAGINGS OF COMBINATION PACKAGINGS (see 6;3.1)

Boxes

Aluminium (4B)
Fibreboard (4G)
Natural wood (4C1, 4C2)
Other metal (4N)
Plastics (4H1, 4H2)
Plywood (4D)
Reconstituted wood (4F)
Steel (4A)

Drums

Aluminium (1B1, 1B2)
Fibre 1G)
Other metal (1N1, 1N2)
Plastics (1H1, 1H2)
Plywood (1D)
Steel (1A1, 1A2)

Jerricans

Aluminium (3B1, 3B2)
Plastics (3H1, 3H2)
Steel (3A1, 3A2)

Packing Instructions 487 – 491

Cargo aircraft only

General requirements

Part 4, Chapter 1 requirements must be met, including:

1) Compatibility requirements

- Substances must be compatible with their packagings as required by 4;1.1.3.
- Metal packagings must be corrosion resistant or be protected against corrosion for substances with a Class 8 subsidiary risk.

2) Closure requirements

- Closures must meet the requirements of 4;1.1.4.

COMBINATION PACKAGINGS					SINGLE PACKAGINGS
<i>Packing instruction</i>	<i>Packing group</i>	<i>Inner packaging (see 6;3.2)</i>	<i>Inner packaging quantity (per receptacle)</i>	<i>Total quantity per package</i>	
487	I	Glass	1.0 kg	15 kg	15 kg
		Plastics	1.0 kg		
		Metal	1.0 kg		
488	I	Glass	1.0 kg	15 kg	15 kg
		Plastics	2.5 kg		
		Metal	2.5 kg		
		Plastic bag	2.5 kg		
489	II	Glass	2.5 kg	50 kg	50 kg
		Plastics	2.5 kg		
		Metal	5.0 kg		
490	II	Glass	2.5 kg	50 kg	50 kg
		Plastics	5.0 kg		
		Metal	5.0 kg		
		Plastic bag	2.5 kg		
491	III	Glass	5.0 kg	100 kg	100 kg
		Plastics	10.0 kg		
		Metal	10.0 kg		
		Plastic bag	5.0 kg		

ADDITIONAL PACKING REQUIREMENTS FOR COMBINATION PACKAGINGS

Packing Group I

- Inner packagings must be hermetically sealed, e.g. by taping or by threaded closures.

Packing Groups I and II

- For wetted substances where the outer packaging is not leakproof, a leakproof liner or equally effective means of intermediate containment must be provided.

Packing Group III

- Packagings must meet the Packing Group II performance requirements.
- For wetted substances where the outer packaging is not leakproof, a leakproof liner or equally effective means of intermediate containment must be provided.

OUTER PACKAGINGS OF COMBINATION PACKAGINGS (see 6;3.1)*Boxes*

Aluminium (4B)
 Fibreboard (4G)
 Natural wood (4C1, 4C2)
 Other metal (4N)
 Plastics (4H1, 4H2)
 Plywood (4D)
 Reconstituted wood (4F)
 Steel (4A)

Drums

Aluminium (1B1, 1B2)
 Fibre (1G)
 Other metal (1N1, 1N2)
 Plastics (1H1, 1H2)
 Plywood (1D)
 Steel (1A1, 1A2)

Jerricans

Aluminium (3B1, 3B2)
 Plastics (3H1, 3H2)
 Steel (3A1, 3A2)

ADDITIONAL PACKING REQUIREMENTS FOR SINGLE PACKAGINGS

- Fibreboard, wood and plywood single packagings must be fitted with a suitable liner.

Packing Group III

- Packagings must meet the Packing Group II performance requirements.

SINGLE PACKAGINGS FOR PACKING GROUP I*Composites*

All (see 6;3.1.18)

Cylinders

See 4;2.7

Drums

Aluminium (1B1, 1B2)
 Other metal (1N1, 1N2)
 Plastics (1H1, 1H2)
 Steel (1A1, 1A2)

Jerricans

Aluminium (3B1, 3B2)
 Plastics (3H1, 3H2)
 Steel (3A1, 3A2)

SINGLE PACKAGINGS FOR PACKING GROUPS II AND III ONLY*Boxes*

Aluminium (4B)
 Fibreboard (4G)
 Natural wood (4C2)
 Other metal (4N)
 Plastics (4H2)
 Plywood (4D)
 Reconstituted wood (4F)
 Steel (4A)

Composites

All (see 6;3.1.18)

Cylinders

See 4;2.7

Drums

Aluminium (1B1, 1B2)
 Other metal (1N1, 1N2)
 Plastics (1H1, 1H2)
 Steel (1A1, 1A2)

Jerricans

Aluminium (3B1, 3B2)
 Plastics (3H1, 3H2)
 Steel (3A1, 3A2)

Packing Instruction 492

Passenger and cargo aircraft for UN 3292 only

General requirements

Part 4, Chapter 1 requirements must be met, including:

1) Compatibility requirements

- Substances must be compatible with their packagings as required by 4;1.1.3.
- Metal packagings must be corrosion resistant or be protected against corrosion.

2) Closure requirements

- Closures must meet the requirements of 4;1.1.4.

COMBINATION PACKAGINGS				SINGLE PACKAGINGS
<i>UN number and proper shipping name</i>	<i>Packing conditions</i>	<i>Total quantity per package — passenger</i>	<i>Total quantity per package — cargo</i>	
UN 3292 Batteries, containing sodium	Batteries may be offered for transport and transported unpacked or in protective enclosures such as fully enclosed or wooden slatted crates that are not subject to the requirements of Part 6 of these Instructions.	Forbidden	No limit	No limit
UN 3292 Cells, containing sodium		25 kg G	No limit	No

ADDITIONAL PACKING REQUIREMENTS FOR COMBINATION PACKAGINGS

- Packagings must meet the Packing Group II performance requirements.
- Batteries must be protected against short circuit and must be isolated in such a manner as to prevent short circuits.

OUTER PACKAGINGS OF COMBINATION PACKAGINGS (see 6;3.1)

Boxes

Aluminium (4B)
Fibreboard (4G)
Natural wood (4C1, 4C2)
Other metal (4N)
Plastics (4H1, 4H2)
Plywood (4D)
Reconstituted wood (4F)
Steel (4A)

Drums

Aluminium (1B2)
Fibre (1G)
Other metal (1N2)
Plastics (1H2)
Steel (1A2)

Jerricans

Aluminium (3B2)
Plastics (3H2)
Steel (3A2)

Packing Instruction 493

Passenger aircraft for UN 3399 only

General requirements

Part 4, Chapter 1 requirements must be met, including:

1) Compatibility requirements

- Substances must be compatible with their packagings as required by 4;1.1.3.

2) Closure requirements

- Closures must meet the requirements of 4;1.1.4.

COMBINATION PACKAGINGS					SINGLE PACKAGINGS
UN number and proper shipping name	Packing group	Inner packaging (see 6;3.2)	Inner packaging quantity (per receptacle)	Total quantity per package	
UN 3399 Organometallic substance, liquid, water reactive, flammable	I	Forbidden			
	II	Glass (see 6;3.2)	1.0 L	1 L	No
		Appropriate cylinders or other pressure vessels (see 4;2.7)	1.0 L	1 L	No
	III	Glass (see 6;3.2)	5.0 L	5 L	No
		Appropriate cylinders or other pressure vessels (see 4;2.7)	5.0 L	5 L	No

ADDITIONAL PACKING REQUIREMENTS FOR COMBINATION PACKAGINGS

- Glass containers must be packed with sufficient absorbent material to absorb the entire contents of the inner packagings and placed in a rigid leakproof receptacle before packing in outer packagings.
- Packagings must meet the Packing Group II performance requirements.

OUTER PACKAGINGS OF COMBINATION PACKAGINGS (see 6;3.1)

Boxes

Aluminium (4B)
Fibreboard (4G)
Natural wood (4C1, 4C2)
Other metal (4N)
Plastics (4H1, 4H2)
Plywood (4D)
Reconstituted wood (4F)
Steel (4A)

Drums

Aluminium (1B1, 1B2)
Fibre (1G)
Other metal (1N1, 1N2)
Plastics (1H1, 1H2)
Steel (1A1, 1A2)

Jerricans

Aluminium (3B1, 3B2)
Plastics (3H1, 3H2)
Steel (3A1, 3A2)

Packing Instruction 494

Cargo aircraft only for UN 3399

General requirements

Part 4, Chapter 1 requirements must be met, including:

1) Compatibility requirements

- Substances must be compatible with their packagings as required by 4;1.1.3.
- Metal packagings must be corrosion resistant or be protected against corrosion for substances with a Class 8 subsidiary risk.

2) Closure requirements

- Closures must meet the requirements of 4;1.1.4.

COMBINATION PACKAGINGS					SINGLE PACKAGINGS
<i>UN number and proper shipping name</i>	<i>Packing group</i>	<i>Inner packaging (see 6;3.2)</i>	<i>Inner packaging quantity (per receptacle)</i>	<i>Total quantity per package</i>	
UN 3399 Organometallic substance, liquid, water reactive, flammable	I	Glass (see 6;3.2)	1.0 L	1.0 L	No
		Appropriate cylinders or other pressure vessels (see 4;2.7)	1.0 L	1.0 L	No
	II	Glass (see 6;3.2)	2.5 L	5 L	No
		Appropriate cylinders or other pressure vessels (see 4;2.7)	2.5 L	5 L	No
	III	Glass (see 6;3.2)	5.0 L	60 L	60 L
		Appropriate cylinders or other pressure vessels (see 4;2.7)	5.0 L	60 L	60 L

ADDITIONAL PACKING REQUIREMENTS FOR COMBINATION PACKAGINGS

Packing Group I

- Inner packagings must have threaded enclosures and must be surrounded in inert cushioning and absorbent material in a quantity sufficient to absorb the entire contents and enclosed in a leakproof liner, plastic bag or other equally effective means of intermediate leakproof containment.

Packing Group II

- Glass inner packagings must be packed with sufficient absorbent material to absorb the entire contents of the inner packagings and enclosed in a leakproof liner, plastic bag or other equally effective means of intermediate leakproof containment.

Packing Group III

- Packagings must meet the Packing Group II performance requirements.

OUTER PACKAGINGS OF COMBINATION PACKAGINGS (see 6;3.1)*Boxes*

Aluminium (4B)
 Fibreboard (4G)
 Natural wood (4C1, 4C2)
 Other metal (4N)
 Plastics (4H1, 4H2)
 Plywood (4D)
 Reconstituted wood (4F)
 Steel (4A)

Drums

Aluminium (1B1, 1B2)
 Fibre (1G)
 Other metal (1N1, 1N2)
 Plastics (1H1, 1H2)
 Steel (1A1, 1A2)

Jerricans

Aluminium (3B1, 3B2)
 Plastics (3H1, 3H2)
 Steel (3A1, 3A2)

SINGLE PACKAGINGS FOR PACKING GROUP III ONLY

Appropriate cylinders or pressure vessels as permitted by 4;2.7.

Packing Instruction 495

Passenger and cargo aircraft for UN 3476 only

General requirements

Part 4;1.1.1, 1.1.2 and 1.1.8 requirements must be met, including:

1) Compatibility requirements

- Substances must be compatible with their packagings as required by 4;1.1.3.

<i>UN number and name</i>	<i>Quantity — passenger</i>	<i>Quantity — cargo</i>
UN 3476 Fuel cell cartridges , containing water-reactive substances	5 kg of fuel cell cartridges	50 kg of fuel cell cartridges

ADDITIONAL PACKING REQUIREMENTS

- Fuel cell cartridges must be securely cushioned in the outer packagings.
- The mass of each fuel cell cartridge must not exceed 1 kg.
- Packagings must meet the Packing Group II performance requirements.

OUTER PACKAGINGS OF COMBINATION PACKAGINGS (see 6;3.1)*Boxes*

Aluminium(4B)
 Fibreboard (4G)
 Natural wood (4C1, 4C2)
 Other metal (4N)
 Plastics (4H2)
 Plywood (4D)
 Reconstituted wood (4F)
 Steel (4A)

Drums

Aluminium(1B2)
 Fibre (1G)
 Other metal (1N2)
 Plastics (1H2)
 Plywood (1D)
 Steel (1A2)

Jerricans

Aluminium (3B2)
 Plastics (3H2)
 Steel (3A2)

Packing Instruction Y495

Limited quantities for UN 3476 only

General requirements

Part 3;4 requirements must be met.

Single packagings are not permitted for limited quantities.

For the purpose of this packing instruction, a fuel cell cartridge is considered an inner packaging.

Fuel cell cartridges containing liquid water reactive fuels are not permitted in limited quantities.

1) Compatibility requirements

- Substances must be compatible with their packagings as required by 4;1.1.3.

<i>UN number and name</i>	<i>Maximum quantity per package</i>
UN 3476 Fuel cell cartridges , containing water-reactive substances	2.5 kg of fuel cell cartridges

ADDITIONAL PACKING REQUIREMENTS

- Fuel cell cartridges must be securely cushioned in the outer packagings.
- Fuel cell cartridges containing solid water reactive fuels must not exceed 0.2 kg solid water reactive fuel per cartridge.

OUTER PACKAGINGS OF COMBINATION PACKAGINGS (see 6;3.1)

Boxes

Aluminium
Fibreboard
Natural wood
Other metal
Plastics
Plywood
Reconstituted wood
Steel

Drums

Aluminium
Fibre
Other metal
Plastics
Plywood
Steel

Jerricans

Aluminium
Plastics
Steel

Packing Instruction 496

Passenger and cargo aircraft for UN 3476 (contained in equipment) only

General requirements

Part 4;1.1.1 and 1.1.8 requirements must be met, including:

1) Compatibility requirements

- Substances must be compatible with their packagings as required by 4;1.1.3.

<i>UN number and name</i>	<i>Quantity — passenger</i>	<i>Quantity — cargo</i>
UN 3476 Fuel cell cartridges contained in equipment , containing water-reactive substances	5 kg of fuel cell cartridges	50 kg of fuel cell cartridges

ADDITIONAL PACKING REQUIREMENTS

- Fuel cell cartridges that are contained in equipment must be protected against short circuit and the equipment must be protected against inadvertent operation.
- Equipment must be securely cushioned in the outer packagings.
- The mass of each fuel cell cartridge must not exceed 1 kg.
- Fuel cell systems must not charge batteries during transport.
- On passenger aircraft, each fuel cell system and each fuel cell cartridge must conform to IEC 62282-6-100 Ed. 1, including Amendment 1, or a standard approved by the appropriate authority of the State of Origin.

OUTER PACKAGINGS OF COMBINATION PACKAGINGS (see 6;3.1)

Boxes

Drums

Jerricans

Strong outer packagings

Packing Instruction 497

Passenger and cargo aircraft for UN 3476 (packed with equipment) only

General requirements

Part 4;1.1.1 and 1.1.8 requirements must be met, including:

1) Compatibility requirements

- Substances must be compatible with their packagings as required by 4;1.1.3.

<i>UN number and name</i>	<i>Quantity — passenger</i>	<i>Quantity — cargo</i>
UN 3476 Fuel cell cartridges packed with equipment , containing water-reactive substances	5 kg of fuel cell cartridges	50 kg of fuel cell cartridges

ADDITIONAL PACKING REQUIREMENTS

- When fuel cell cartridges are packed with equipment, they must be packed in intermediate packagings together with the equipment they are capable of powering.
- The maximum number of fuel cell cartridges in the intermediate packaging must be the minimum number required to power the equipment, plus two spares.
- The fuel cell cartridges and the equipment must be packed with cushioning material or divider(s) or inner packaging so that the fuel cell cartridges are protected against damage that may be caused by the movement or placement of the equipment and the cartridges within the packaging.
- The mass of each fuel cell cartridge must not exceed 1 kg.

OUTER PACKAGINGS OF COMBINATION PACKAGINGS (see 6;3.1)

Boxes

Drums

Jerricans

Strong outer packagings

Packing Instruction 499

Only packagings which are approved by the appropriate national authority for these substances may be used (see 4;2.8). A copy of this approval must accompany each consignment or an annotation that it has been granted must be included with the transport document.

Chapter 7

CLASS 5 — OXIDIZING SUBSTANCES; ORGANIC PEROXIDES

7.1 GENERAL REQUIREMENTS FOR ORGANIC PEROXIDES

7.1.1 Packagings for organic peroxides must conform to the requirements of 6;1, 6;2, 6;3 and 6;4 and must meet the test requirements of 6;4 for Packing Group II.

7.1.2 Venting of packages is not permitted for air transport.

7.1.3 The packaging of organic peroxides presenting an explosive subsidiary risk must comply with the provisions of 4;3.2.2 and 4;3.2.3.

7.2 PACKING INSTRUCTIONS

Packing Instructions Y540 – Y541

Limited quantities
Passenger and cargo aircraft

General requirements

Part 4, Chapter 1 requirements must be met (except that 4;1.1.2, 1.1.9 c), 1.1.9 e), 1.1.16, 1.1.18 and 1.1.20 do not apply), including:

1) Compatibility requirements

- Substances must be compatible with their packagings as required by 4;1.1.3.
- Metal packagings must be corrosion resistant or be protected against corrosion for substances with a Class 8 subsidiary risk.

2) Closure requirements

- Closures must meet the requirements of 4;1.1.4.

3) Limited quantity requirements

- Part 3, Chapter 4 requirements must be met including:
 - the capability of the package to pass a 1.2 m drop test;
 - a 24-hour stacking test; and
 - inner packagings for liquids must be capable of passing a pressure differential test (4;1.1.6).

COMBINATION PACKAGINGS						SINGLE PACKAGINGS
Packing instruction	Packing group	Inner packaging (see 6;3.2)	Inner packaging quantity (per receptacle)	Total quantity per package	Total gross mass per package	
Y540	II	Glass	0.1 L	0.5 L	30 kg	No
		Plastics	0.1 L			
		Metal	0.1 L			
Y541	III	Glass	0.5 L	1.0 L		No
		Plastics	0.5 L			
		Metal	0.5 L			

OUTER PACKAGINGS OF COMBINATION PACKAGINGS (see 6;3.1)*Boxes*

Aluminium
Fibreboard
Natural wood
Other metal
Plastics
Plywood
Reconstituted wood
Steel

Drums

Aluminium
Fibre
Other metal
Plastics
Steel

Jerricans

Aluminium
Plastics
Steel

Packing Instructions Y543 – Y546

Limited quantities
Passenger and cargo aircraft

General requirements

Part 4, Chapter 1 requirements must be met (except that 4;1.1.2, 1.1.9 c), 1.1.9 e), 1.1.16, 1.1.18 and 1.1.20 do not apply), including:

1) Compatibility requirements

- Substances must be compatible with their packagings as required by 4;1.1.3.
- Metal packagings must be corrosion resistant or be protected against corrosion for substances with a Class 8 subsidiary risk.

2) Closure requirements

- Closures must meet the requirements of 4;1.1.4.

3) Limited quantity requirements

- Part 3, Chapter 4 requirements must be met including:
 - the capability of the package to pass a 1.2 m drop test; and
 - a 24-hour stacking test.

COMBINATION PACKAGINGS						SINGLE PACKAGINGS
<i>Packing instruction</i>	<i>Packing group</i>	<i>Inner packaging (see 6;3.2)</i>	<i>Inner packaging quantity (per receptacle)</i>	<i>Total quantity per package</i>	<i>Total gross mass per package</i>	
Y543	II	Glass	0.5 kg	1.0 kg	30 kg	No
		Plastics	0.5 kg			
		Metal	0.5 kg			
		Paper bag	0.5 kg			
		Plastic bag	0.5 kg			
		Fibre	0.5 kg			
Y544	II	Glass	0.5 kg	2.5 kg	30 kg	No
		Plastics	0.5 kg			
		Metal	0.5 kg			
		Paper bag	0.5 kg			
		Plastic bag	0.5 kg			
		Fibre	0.5 kg			
Y545	III	Glass	1.0 kg	5 kg	30 kg	No
		Plastics	1.0 kg			
		Metal	1.0 kg			

		Paper bag	1.0 kg			
		Plastic bag	1.0 kg			
		Fibre	1.0 kg			
Y546	III	Glass	1.0 kg	10 kg	30 kg	No
		Plastics	1.0 kg			
		Metal	1.0 kg			
		Paper bag	1.0 kg			
		Plastic bag	1.0 kg			
		Fibre	1.0 kg			

OUTER PACKAGINGS OF COMBINATION PACKAGINGS (see 6;3.1)
Boxes

Aluminium
Fibreboard
Natural wood
Other metal
Plastics
Plywood
Reconstituted wood
Steel

Drums

Aluminium
Fibre
Other metal
Plastics
Steel

Jerricans

Aluminium
Plastics
Steel

Packing Instructions 550 – 551

Passenger aircraft

General requirements

Part 4, Chapter 1 requirements must be met, including:

1) Compatibility requirements

- Substances must be compatible with their packagings as required by 4;1.1.3.
- Metal packagings must be corrosion resistant or be protected against corrosion for substances with a Class 8 subsidiary risk.

2) Closure requirements

- Closures must meet the requirements of 4;1.1.4.

COMBINATION PACKAGINGS					SINGLE PACKAGINGS
Packing instruction	Packing group	Inner packaging (see 6;3.2)	Inner packaging quantity (per receptacle)	Total quantity per package	
—	I	Forbidden			
550	II	Glass	1.0 L	1 L	No
		Plastics	1.0 L		
		Metal	1.0 L		
551	III	Glass	2.5 L	2.5 L	No
		Plastics	2.5 L		
		Metal	2.5 L		

ADDITIONAL PACKING REQUIREMENTS FOR COMBINATION PACKAGINGS
Packing Group III

- Packagings must meet the Packing Group II performance requirements.

OUTER PACKAGINGS OF COMBINATION PACKAGINGS (see 6;3.1)*Boxes*

Aluminium (4B)
 Fibreboard (4G)
 Natural wood (4C1, 4C2)
 Other metal (4N)
 Plastics (4H1, 4H2)
 Plywood (4D)
 Reconstituted wood (4F)
 Steel (4A)

Drums

Aluminium (1B1, 1B2)
 Fibre (1G)
 Other metal (1N1, 1N2)
 Plastics (1H1, 1H2)
 Steel (1A1, 1A2)

Packing Instructions 553 – 555

Cargo aircraft only

General requirements

Part 4, Chapter 1 requirements must be met, including:

1) Compatibility requirements

- Substances must be compatible with their packagings as required by 4;1.1.3.
- Metal packagings must be corrosion resistant or be protected against corrosion for substances with a Class 8 subsidiary risk.

2) Closure requirements

- Closures must meet the requirements of 4;1.1.4.

COMBINATION PACKAGINGS					SINGLE PACKAGINGS
<i>Packing instruction</i>	<i>Packing group</i>	<i>Inner packaging (see 6;3.2)</i>	<i>Inner packaging quantity (per receptacle)</i>	<i>Total quantity per package</i>	
553	I	Glass	1.0 L	2.5 L	No
		Plastics	1.0 L		
		Metal	1.0 L		
554	II	Glass	2.5 L	5 L	No
		Plastics	2.5 L		
		Metal	2.5 L		
555	III	Glass	5.0 L	30 L	30 L
		Plastics	5.0 L		
		Metal	5.0 L		

ADDITIONAL PACKING REQUIREMENTS FOR COMBINATION PACKAGINGS*Packing Group I*

- UN 1873 only glass inner packagings are permitted.
- Inner packagings must be packed with sufficient absorbent material to absorb the entire contents of the inner packagings and placed in a rigid leakproof receptacle before packing in outer packagings.

Packing Group III

- Packagings must meet the Packing Group II performance requirements.

OUTER PACKAGINGS OF COMBINATION PACKAGINGS (see 6;3.1)*Boxes*

Aluminium (4B)
 Fibreboard (4G)
 Natural wood (4C1, 4C2)
 Other metal (4N)
 Plastics (4H1, 4H2)
 Plywood (4D)
 Reconstituted wood (4F)
 Steel (4A)

Drums

Aluminium (1B1, 1B2)
 Fibre (1G)
 Other metal (1N1, 1N2)
 Plastics (1H1, 1H2)
 Steel (1A1, 1A2)

ADDITIONAL PACKING REQUIREMENTS FOR SINGLE PACKAGINGS*Packing Group III*

- Packagings must meet the Packing Group II performance requirements.

SINGLE PACKAGINGS FOR PACKING GROUP III (PI 555)*Composites*

All (see 6;3.1.18)

Drums

Aluminium (1B1)
 Other metal (1N1)
 Plastics (1H1)
 Steel (1A1)

Jerricans

Aluminium (3B1)
 Plastics (3H1)
 Steel (3A1)

Packing Instructions 557 – 559

Passenger aircraft

General requirements

Part 4, Chapter 1 requirements must be met, including:

1) Compatibility requirements

- Substances must be compatible with their packagings as required by 4;1.1.3.
- Metal packagings must be corrosion resistant or be protected against corrosion for substances with a Class 8 subsidiary risk.

2) Closure requirements

- Closures must meet the requirements of 4;1.1.4.

COMBINATION PACKAGINGS					SINGLE PACKAGINGS
Packing instruction	Packing group	Inner packaging (see 6;3.2)	Inner packaging quantity (per receptacle)	Total quantity per package	
557	I	Glass	1.0 kg	1 kg	No
		Plastics	1.0 kg		
		Metal	1.0 kg		
558	II	Glass	1.0 kg	5 kg	No
		Plastics	1.0 kg		
		Metal	1.0 kg		
		Paper bag	1.0 kg		
		Plastic bag	1.0 kg		
		Fibre	1.0 kg		
559	III	Glass	2.5 kg	25 kg	No
		Plastics	2.5 kg		
		Metal	2.5 kg		
		Paper bag	2.5 kg		
		Plastic bag	2.5 kg		
		Fibre	2.5 kg		

ADDITIONAL PACKING REQUIREMENTS FOR COMBINATION PACKAGINGS

Packing Groups I and II

- For wetted substances where the outer packaging is not leakproof, a leakproof liner or equally effective means of intermediate containment must be provided.

Packing Group III

- Packagings must meet the Packing Group II performance requirements.
- For wetted substances where the outer packaging is not leakproof, a leakproof liner or equally effective means of intermediate containment must be provided.

OUTER PACKAGINGS OF COMBINATION PACKAGINGS FOR PACKING GROUP I

Boxes

Aluminium (4B)
Fibreboard (4G)
Natural wood (4C1, 4C2)
Other metal (4N)
Plastics (4H1, 4H2)
Plywood (4D)
Reconstituted wood (4F)
Steel (4A)

Drums

Aluminium (1B1, 1B2)
Fibre (1G)
Other metal (1N1, 1N2)
Plastics (1H1, 1H2)
Plywood (1D)
Steel (1A1, 1A2)

OUTER PACKAGINGS OF COMBINATION PACKAGINGS FOR PACKING GROUPS II AND III

Boxes

Aluminium (4B)
Fibreboard (4G)
Natural wood (4C1, 4C2)
Other metal (4N)
Plastics (4H1, 4H2)
Plywood (4D)
Reconstituted wood (4F)
Steel (4A)

Drums

Aluminium (1B1, 1B2)
Fibre (1G)
Other metal (1N1, 1N2)
Plastics (1H1, 1H2)
Plywood (1D)
Steel (1A1, 1A2)

Jerricans

Aluminium (3B1, 3B2)
Plastics (3H1, 3H2)
Steel (3A1, 3A2)

Packing Instructions 561 – 563

Cargo aircraft only

General requirements

Part 4, Chapter 1 requirements must be met, including:

1) Compatibility requirements

- Substances must be compatible with their packagings as required by 4;1.1.3.
- Metal packagings must be corrosion resistant or be protected against corrosion for substances with a Class 8 subsidiary risk.

2) Closure requirements

- Closures must meet the requirements of 4;1.1.4.

COMBINATION PACKAGINGS					SINGLE PACKAGINGS
<i>Packing instruction</i>	<i>Packing group</i>	<i>Inner packaging (see 6;3.2)</i>	<i>Inner packaging quantity (per receptacle)</i>	<i>Total quantity per package</i>	
561	I	Glass	1.0 kg	15 kg	15 kg
		Plastics	1.0 kg		
		Metal	1.0 kg		
562	II	Glass	2.5 kg	25 kg	25 kg
		Plastics	2.5 kg		
		Metal	5.0 kg		
		Paper bag	2.5 kg		
		Plastic bag	2.5 kg		
		Fibre	2.5 kg		
563	III	Glass	5.0 kg	100 kg	100 kg
		Plastics	5.0 kg		
		Metal	5.0 kg		
		Paper bag	5.0 kg		
		Plastic bag	5.0 kg		
		Fibre	5.0 kg		

ADDITIONAL PACKING REQUIREMENTS FOR COMBINATION PACKAGINGS

Packing Groups I and II

- For wetted substances where the outer packaging is not leakproof, a leakproof liner or equally effective means of intermediate containment must be provided.

Packing Group III

- Packagings must meet the Packing Group II performance requirements.
- For wetted substances where the outer packaging is not leakproof, a leakproof liner or equally effective means of intermediate containment must be provided.

OUTER PACKAGINGS OF COMBINATION PACKAGINGS FOR PACKING GROUP I

<i>Boxes</i>	<i>Drums</i>
Aluminium (4B)	Aluminium (1B1, 1B2)
Fibreboard (4G)	Fibre (1G)
Natural wood (4C1, 4C2)	Other metal (1N1, 1N2)
Other metal (4N)	Plastics (1H1, 1H2)
Plastics (4H1, 4H2)	Plywood (1D)
Plywood (4D)	Steel (1A1, 1A2)
Reconstituted wood (4F)	
Steel (4A)	

OUTER PACKAGINGS OF COMBINATION PACKAGINGS FOR PACKING GROUPS II AND III ONLY

<i>Boxes</i>	<i>Drums</i>	<i>Jerricans</i>
Aluminium (4B)	Aluminium (1B1, 1B2)	Aluminium (3B1, 3B2)
Fibreboard (4G)	Fibre (1G)	Plastics (3H1, 3H2)
Natural wood (4C1, 4C2)	Other metal (1N1, 1N2)	Steel (3A1, 3A2)
Other metal (4N)	Plastics (1H1, 1H2)	
Plastics (4H1, 4H2)	Plywood (1D)	
Plywood (4D)	Steel (1A1, 1A2)	
Reconstituted wood (4F)		
Steel (4A)		

ADDITIONAL PACKING REQUIREMENTS FOR SINGLE PACKAGINGS

Fibre, fibreboard, wood and plywood single packagings must be fitted with a suitable liner.

Packing Group III

- Packagings must meet the Packing Group II performance requirements.

SINGLE PACKAGINGS FOR PACKING GROUP I*Drums*

Aluminium (1B1, 1B2)
Other metal (1N1, 1N2)
Steel (1A1, 1A2)

SINGLE PACKAGINGS FOR PACKING GROUPS II AND III

<i>Boxes</i>	<i>Composites</i>	<i>Cylinders</i>	<i>Drums</i>	<i>Jerricans</i>
Aluminium (4B)	All (see 6;3.1.18)	See 4;2.7	Aluminium (1B1, 1B2)	Aluminium (3B1, 3B2)
Fibreboard (4G)			Fibre (1G)	Plastics (3H1, 3H2)
Natural wood (4C2)			Other metal (1N1, 1N2)	Steel (3A1, 3A2)
Other metal (4N)			Plastics (1H1, 1H2)	
Plastics (4H2)			Plywood (1D)	
Plywood (4D)			Steel (1A1, 1A2)	
Reconstituted wood (4F)				
Steel (4A)				

Packing Instruction 565

Cargo aircraft for UN 3356 only

General requirements

Part 4, Chapter 1 requirements must be met, including:

1) Compatibility requirements

- Substances must be compatible with their packagings as required by 4;1.1.3.
- Metal packagings must be corrosion resistant or be protected against corrosion.

2) Closure requirements

- Closures must meet the requirements of 4;1.1.4.

COMBINATION PACKAGINGS				SINGLE PACKAGINGS
<i>UN number and proper shipping name</i>	<i>Packing conditions</i>	<i>Total quantity per package — passenger</i>	<i>Total quantity per package — cargo</i>	
UN 3356 Oxygen generator, chemical	The generators must be tightly packed in the outer packagings listed below.	Forbidden	25 kg	Unpackaged No

ADDITIONAL PACKING REQUIREMENTS FOR COMBINATION PACKAGINGS

- a) The generator, without its packaging, must be capable of withstanding a 1.8 m drop test onto a rigid, non-resilient, flat and horizontal surface, in the position most likely to cause actuation, without loss of its contents and without actuation. For portable breathing equipment (PBE), which are in a vacuum-sealed bag as part of their containment system, this test may be conducted on the PBE in the vacuum-sealed bag.
- b) When a generator is equipped with an actuating device, it must have at least two positive means of preventing unintentional actuation as follows:
 - 1) mechanically actuated devices:
 - i) two pins, installed so that each is independently capable of preventing the actuator from striking the primer;
 - ii) one pin and one retaining ring, each installed so that each is independently capable of preventing the actuator from striking the primer; or
 - iii) a cover securely installed over the primer and a pin installed so as to prevent the actuator from striking the primer and cover.
 - 2) electrically actuated devices: The electrical leads must be mechanically shorted and the mechanical short must be shielded in metal foil;
 - 3) for PBE:
 - i) a pin so as to prevent the actuator from striking the primer; and
 - ii) placed in protective packaging such as a vacuum-sealed bag;
- c) The generator(s) must be transported in a package which will meet the following requirements when one generator in the package is actuated:
 - 1) other generators in the package will not be actuated;
 - 2) packaging material will not ignite; and
 - 3) the outside surface temperature of the completed package will not exceed 100°C.

Note.— To enable tests 1), 2) and 3) to be conducted on PBE, it is acceptable to break the vacuum-sealed bag to actuate the generator before placing it in the package.

OUTER PACKAGINGS OF COMBINATION PACKAGINGS (see 6;3.1)*Boxes*

Aluminium (4B)
 Fibreboard (4G)
 Natural wood (4C1, 4C2)
 Plastics (4H1, 4H2)
 Plywood (4D)
 Reconstituted wood (4F)
 Steel (4A)

Drums

Aluminium (1B2)
 Fibre (1G)
 Other metal (1N2)
 Plastics (1H2)
 Steel (1A2)

Jerricans

Aluminium (3B2)
 Plastics (3H2)
 Steel (3A2)

Packing Instruction 570

Passenger and cargo aircraft

General requirements

Part 4, Chapter 1 requirements must be met, including:

1) Compatibility requirements

— Substances must be compatible with their packagings as required by 4;1.1.3.

2) Closure requirements

— Closures must meet the requirements of 4;1.1.4.

COMBINATION PACKAGINGS							SINGLE PACKAGINGS
<i>UN number and proper shipping name</i>	<i>Inner packaging (see 6;3.2)</i>	<i>Inner packaging quantity (per receptacle)— passenger</i>	<i>Total quantity per package — passenger</i>	<i>Inner packaging quantity (per receptacle)— cargo</i>	<i>Total quantity per package — cargo</i>		
Liquids							No
UN 3103	Organic peroxide type C, liquid	Plastics	0.5 L	5 L	1.0 L	10 L	
UN 3105	Organic peroxide type D, liquid	Plastics	0.5 L	5 L	1.0 L	10 L	
UN 3107	Organic peroxide type E, liquid	Plastics	1.0 L	10 L	2.5 L	25 L	
UN 3109	Organic peroxide type F, liquid	Plastics	1.0 L	10 L	2.5 L	25 L	
Solids							No
UN 3104	Organic peroxide type C, solid	Plastics and plastic bag	0.5 kg	5 kg	1.0 kg	10 kg	
UN 3106	Organic peroxide type D, solid	Plastics and plastic bag	0.5 kg	5 kg	1.0 kg	10 kg	
UN 3108	Organic peroxide type E, solid	Plastics and plastic bag	1.0 kg	10 kg	2.5 kg	25 kg	
UN 3110	Organic peroxide type F, solid	Plastics and plastic bag	1.0 kg	10 kg	2.5 kg	25 kg	

ADDITIONAL PACKING REQUIREMENTS FOR COMBINATION PACKAGINGS

— Packagings must meet the Packing Group II performance requirements.

+ *Cargo aircraft only*

+ Inner packagings of peroxyacetic acid, stabilized (classified as UN 3107 **Organic peroxide type E, liquid** or UN 3109 **Organic peroxide type F, liquid**) may be fitted with a vent consisting of hydrophobic membrane when the substance is used for purposes such as sterilization, provided:

- a) each inner packaging contains not more than 70 mL;
- b) the inner packaging is designed so that the vent is not immersed in liquid in any orientation;
- c) each inner packaging is enclosed in an intermediate rigid plastic packaging with a small opening to permit release of gas and contains a buffer that neutralizes the contents of the inner packaging in the event of leakage;
- d) intermediate packagings are packed in a fibreboard box (4G) outer packaging;
- e) each outer packaging contains not more than 1.4 L of liquid; and
- f) the rate of oxygen release from the outer packaging does not exceed 15 mL per hour.

+ Such packages must be transported on cargo aircraft only. The requirements of 4;1.1.6, 4;1.1.12 and 4;7.1.2 do not apply.

OUTER PACKAGINGS OF COMBINATION PACKAGINGS (see 6;3.1)

	<i>Boxes</i>	<i>Drums</i>	<i>Jerricans</i>
>	Fibreboard (4G) Natural wood (4C1, 4C2) Plastics (4H1, 4H2) Plywood (4D) Reconstituted wood (4F)	Fibre (1G) Plastics (1H1, 1H2) Plywood (1D)	Plastics (3H1, 3H2)

Chapter 8

CLASS 6 — TOXIC AND INFECTIOUS SUBSTANCES

8.1 PACKING INSTRUCTIONS

Packing Instruction 620

This packing instruction applies to UN 2814 and UN 2900.

The following packagings are authorized provided the special packing provisions are met.

Packagings meeting the requirements of 6;6 and approved accordingly consisting of:

- a) inner packagings comprising:
 - 1) leakproof primary receptacle(s);
 - 2) a leakproof secondary packaging;
 - 3) other than for solid infectious substances, an absorbent material in sufficient quantity to absorb the entire contents placed between the primary receptacle(s) and the secondary packaging; if multiple fragile primary receptacles are placed in a single secondary packaging, they must be either individually wrapped or separated so as to prevent contact between them;
- b) a rigid outer packaging. The smallest external dimension must be not less than 100 mm.

Additional requirements:

- c) Inner packagings containing infectious substances must not be consolidated with inner packagings containing unrelated types of goods. Complete packages may be overpacked in accordance with the provisions of 1;3.1 and 5;2.4.10. Such an overpack may contain dry ice.
- d) Other than for exceptional consignments, e.g. whole organs, which require special packaging, the following additional requirements must apply:
 - 1) Substances consigned at ambient temperatures or at a higher temperature. Primary receptacles must be of glass, metal or plastics. Positive means of ensuring a leakproof seal must be provided, e.g. a heat seal, a skirted stopper or a metal crimp seal. If screw caps are used, they must be secured by positive means, e.g. tape, paraffin sealing tape or manufactured locking closure;
 - 2) Substances consigned refrigerated or frozen. Ice, dry ice or other refrigerant must be placed around the secondary packaging(s) or, alternatively, in an overpack with one or more complete packages marked in accordance with 6;6.3. Interior supports must be provided to secure secondary packaging(s) or packages in position after the ice or dry ice has dissipated. If ice is used, the outer packaging or overpack must be leakproof. If dry ice is used, the outer packaging or overpack must permit the release of carbon dioxide gas. The primary receptacle and the secondary packaging must maintain their integrity at the temperature of the refrigerant used;
 - 3) Substances consigned in liquid nitrogen. Plastic primary receptacles capable of withstanding very low temperature must be used. The secondary packaging must also be capable of withstanding very low temperatures and, in most cases, will need to be fitted over the primary receptacle individually. Provisions for the consignment of liquid nitrogen must also be fulfilled. The primary receptacle and the secondary packaging must maintain their integrity at the temperature of the liquid nitrogen;
 - 4) Lyophilized substances may also be transported in primary receptacles that are flame-sealed glass ampoules or rubberstoppered glass vials fitted with metal seals.
- e) Whatever the intended temperature of the consignment, the primary receptacle or the secondary packaging must be capable of withstanding, without leakage, an internal pressure producing a pressure differential of not less than 95 kPa and temperatures in the range -40°C to $+55^{\circ}\text{C}$.

Note.— The capability of a packaging to withstand an internal pressure without leakage that produces the specified pressure differential should be determined by testing samples of primary receptacles or secondary packagings. Pressure differential is the difference between the pressure exerted on the inside of the receptacle or packaging and the pressure on the outside. The appropriate test method should be selected based on receptacle or packaging type. Acceptable test methods include any method that produces the required pressure differential between the inside and outside of a primary receptacle or a secondary packaging. The test may be conducted using internal hydraulic or pneumatic pressure (gauge) or external vacuum test methods. Internal hydraulic or pneumatic pressure can be applied in most cases as the required pressure differential can be achieved under most circumstances. An external vacuum test is not acceptable if the specified pressure differential is not achieved and maintained. The external vacuum test is a generally acceptable method for rigid receptacles and packagings but is not normally acceptable for:

- flexible receptacles and flexible packagings;
 - receptacles and packagings filled and closed under an absolute atmospheric pressure lower than 95 kPa.
- f) Other dangerous goods must not be packed in the same packaging as Division 6.2 infectious substances unless they are necessary for maintaining the viability, stabilizing or preventing degradation or neutralizing the hazards of the infectious substances. A quantity of 30 ml or less of dangerous goods included in Class 3, 8 or 9 may be packed in each primary receptacle containing infectious substances provided these substances meet the requirements of 3;5. These small quantities of dangerous goods of Class 3, 8 or 9 are not subject to any additional requirements of these Instructions when packed in accordance with this packing instruction.
- g) Alternative packagings for the transport of animal material may be authorized by the competent authority in accordance with the provisions of 4;2.8.

Special packing provisions

- a) Shippers of infectious substances must ensure that packages are prepared in such a manner that they arrive at their destination in good condition and present no hazard to persons or animals during transport.
- b) The definition in 1;3, and the general packing requirements of 4;1, apply to infectious substances packages.
- c) An itemized list of contents must be enclosed between the secondary packaging and the outer packaging. When the infectious substances to be transported are unknown, but suspected of meeting the criteria for inclusion in Category A, the words “suspected Category A infectious substance” must be shown in parentheses following the proper shipping name on the itemized list of contents inside the outer packaging.
- d) Before an empty packaging is returned to the shipper, or sent elsewhere, it must be disinfected or sterilized to nullify any hazard, and any label or marking indicating that it had contained an infectious substance must be removed or obliterated.

Packing Instruction 622

The general packing requirements of 4;1 except 1.1.20 must be met.

Consignments must be prepared in such a manner that they arrive at their destination in good condition and present no hazard to persons or animals during transport.

Consignments must be packed in steel drums (1A2), aluminium drums (1B2), other metal drums (1N2), plywood drums (1D), fibre drums (1G), plastic drums (1H2), steel jerricans (3A2), aluminium jerricans (3B2), plastic jerricans (3H2), steel boxes (4A), aluminium boxes (4B), wooden boxes (4C1, 4C2), plywood boxes (4D), reconstituted wood boxes (4F) or fibreboard boxes (4G), plastic boxes (4H1, 4H2), other metal boxes (4N). Packagings must meet Packing Group II requirements.

The packaging tests may be those appropriate for solids when there is sufficient absorbent material to absorb the entire amount of liquid present and the packaging is capable of retaining liquids.

In all other circumstances, the packaging tests must be those appropriate for liquids.

Packagings intended to contain sharp objects such as broken glass and needles must be resistant to puncture and retain liquids under the performance test conditions for the packaging.

Packing Instructions Y640 – Y642

Limited quantities
Passenger and cargo aircraft

General requirements

Part 4, Chapter 1 requirements must be met (except that 4;1.1.2, 1.1.9 c), 1.1.9 e), 1.1.16, 1.1.18 and 1.1.20 do not apply), including:

1) Compatibility requirements

- Substances must be compatible with their packagings as required by 4;1.1.3.
- Metal packagings must be corrosion resistant or be protected against corrosion for substances with a Class 8 subsidiary risk.

2) Closure requirements

- Closures must meet the requirements of 4;1.1.4.

3) Limited quantity requirements

- Part 3, Chapter 4 requirements must be met including:
 - the capability of the package to pass a 1.2 m drop test;
 - a 24-hour stacking test; and
 - inner packagings for liquids must be capable of passing a pressure differential test (4;1.1.6).

COMBINATION PACKAGINGS						SINGLE PACKAGINGS		
<i>Packing instruction</i>	<i>Packing group</i>	<i>Inner packaging (see 6;3.2)</i>	<i>Inner packaging quantity (per receptacle)</i>	<i>Total quantity per package</i>	<i>Total gross mass per package</i>			
Y640	II	Glass	0.1 L	0.5 L	30 kg	No		
		Plastics	0.1 L					
		Metal	0.1 L					
Y641	II	Glass	0.1 L	1.0 L		30 kg	No	
		Plastics	0.1 L					
		Metal	0.1 L					
Y642	III	Glass	0.5 L	2.0 L			30 kg	No
		Plastics	0.5 L					
		Metal	0.5 L					

OUTER PACKAGINGS OF COMBINATION PACKAGINGS (see 6;3.1)

Boxes

Aluminium
Fibreboard
Natural wood
Other metal
Plastics
Plywood
Reconstituted wood
Steel

Drums

Aluminium
Fibre
Other metal
Plastics
Steel

Jerricans

Aluminium
Plastics
Steel

Packing Instructions Y644 – Y645

Limited quantities
Passenger and cargo aircraft

General requirements

Part 4, Chapter 1 requirements must be met (except that 4;1.1.2, 1.1.9 c), 1.1.9 e), 1.1.16, 1.1.18 and 1.1.20 do not apply), including:

1) Compatibility requirements

- Substances must be compatible with their packagings as required by 4;1.1.3.
- Metal packagings must be corrosion resistant or be protected against corrosion for substances with a Class 8 subsidiary risk.

2) Closure requirements

- Closures must meet the requirements of 4;1.1.4.

3) Limited quantity requirements

- Part 3, Chapter 4 requirements must be met including:
 - the capability of the package to pass a 1.2 m drop test; and
 - a 24-hour stacking test.

COMBINATION PACKAGINGS						SINGLE PACKAGINGS
Packing instruction	Packing group	Inner packaging (see 6;3.2)	Inner packaging quantity (per receptacle)	Total quantity per package	Total gross mass per package	
Y644	II	Glass	0.5 kg	1 kg	30 kg	No
		Plastics	0.5 kg			
		Metal	0.5 kg			
		Paper bag	0.5 kg			
		Plastic bag	0.5 kg			
		Fibre	0.5 kg			
Y645	III	Glass	1.0 kg	10 kg	30 kg	No
		Plastics	1.0 kg			
		Metal	1.0 kg			
		Paper bag	1.0 kg			
		Plastic bag	1.0 kg			
		Fibre	1.0 kg			

OUTER PACKAGINGS OF COMBINATION PACKAGINGS (see 6;3.1)

Boxes

Aluminium
Fibreboard
Natural wood
Other metal
Plastics
Plywood
Reconstituted wood
Steel

Drums

Aluminium
Fibre
Other metal
Plastics
Steel

Jerricans

Aluminium
Plastics
Steel

Packing Instruction 650

This packing instruction applies to UN 3373.

- 1) The packaging must be of good quality, strong enough to withstand the shocks and loadings normally encountered during transport, including transshipment between transport units and between transport units and warehouses as well as any removal from a pallet or overpack for subsequent manual or mechanical handling. Packagings must be constructed and closed to prevent any loss of contents that might be caused under normal conditions of transport by vibration or by changes in temperature, humidity or pressure.
- 2) The packaging must consist of three components:
 - a) a primary receptacle;
 - b) a secondary packaging; and
 - c) a rigid outer packaging.
- 3) Primary receptacles must be packed in secondary packagings in such a way that, under normal conditions of transport, they cannot break, be punctured or leak their contents into the secondary packaging. Secondary packagings must be secured in outer packagings with suitable cushioning material. Any leakage of the contents must not compromise the integrity of the cushioning material or of the outer packaging.
- 4) For transport, the mark illustrated below must be displayed on the external surface of the outer packaging on a background of a contrasting colour and must be clearly visible and legible. The mark must be in the form of a square set at an angle of 45° (diamond-shaped) with each side having a length of at least 50 mm, the width of the line must be at least 2 mm, and the letters and numbers must be at least 6 mm high. The proper shipping name "Biological substance, Category B" in letters at least 6 mm high must be marked on the outer packaging adjacent to the diamond-shaped mark.

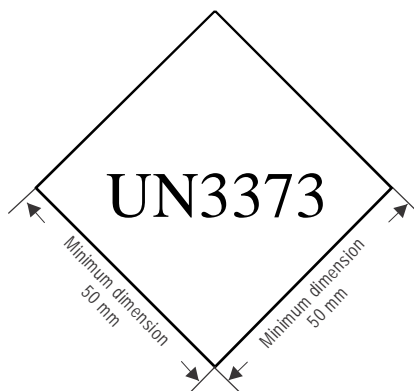

- 5) At least one surface of the outer packaging must have a minimum dimension of 100 mm × 100 mm.
- 6) The completed package must be capable of successfully passing the drop test in 6;6.5.3 as specified in 6;6.5.2 of the Instructions except that the height of the drop must not be less than 1.2 m. Following the appropriate drop sequence, there must be no leakage from the primary receptacle(s) which must remain protected by absorbent material, when required, in the secondary packaging.
- 7) For liquid substances:
 - a) The primary receptacle(s) must be leakproof and must not contain more than 1 litre;
 - b) The secondary packaging must be leakproof;
 - c) If multiple fragile primary receptacles are placed in a single secondary packaging, they must be either individually wrapped or separated to prevent contact between them;
 - d) Absorbent material must be placed between the primary receptacle(s) and the secondary packaging. The absorbent material must be in quantity sufficient to absorb the entire contents of the primary receptacle(s) so that any release of the liquid substance will not compromise the integrity of the cushioning material or of the outer packaging;

- e) The primary receptacle or the secondary packaging must be capable of withstanding, without leakage, an internal pressure of 95 kPa (0.95 bar);
- f) The outer package must not contain more than 4 litres. This quantity excludes ice, dry ice or liquid nitrogen when used to keep specimens cold.

Note.— The capability of a packaging to withstand an internal pressure without leakage that produces the specified pressure differential should be determined by testing samples of primary receptacles or secondary packagings. Pressure differential is the difference between the pressure exerted on the inside of the receptacle or packaging and the pressure on the outside. The appropriate test method should be selected based on receptacle or packaging type. Acceptable test methods include any method that produces the required pressure differential between the inside and outside of a primary receptacle or a secondary packaging. The test may be conducted using internal hydraulic or pneumatic pressure (gauge) or external vacuum test methods. Internal hydraulic or pneumatic pressure can be applied in most cases as the required pressure differential can be achieved under most circumstances. An external vacuum test is not acceptable if the specified pressure differential is not achieved and maintained. The external vacuum test is a generally acceptable method for rigid receptacles and packagings but is not normally acceptable for:

- flexible receptacles and flexible packagings;
- receptacles and packagings filled and closed under an absolute atmospheric pressure lower than 95 kPa.

- 8) For solid substances:
 - a) The primary receptacle(s) must be siftproof and must not exceed the outer packaging mass limit;
 - b) The secondary packaging must be siftproof;
 - c) If multiple fragile primary receptacles are placed in a single secondary packaging, they must be either individually wrapped or separated to prevent contact between them;
 - d) Except for packages containing body parts, organs or whole bodies, the outer package must not contain more than 4 kg. This quantity excludes ice, dry ice or liquid nitrogen when used to keep specimens cold;
 - e) If there is any doubt as to whether or not residual liquid may be present in the primary receptacle during transport, then a packaging suitable for liquids, including absorbent materials, must be used.
- 9) Refrigerated or frozen specimens: ice, dry ice and liquid nitrogen:
 - a) When dry ice or liquid nitrogen is used to keep specimens cold, all applicable requirements of these Instructions must be met. When used, ice or dry ice must be placed outside the secondary packagings or in the outer packaging or an overpack. Interior supports must be provided to secure the secondary packagings in the original position after the ice or dry ice has dissipated. If ice is used, the outside packaging or overpack must be leakproof. If carbon dioxide, solid (dry ice) is used, the packaging must be designed and constructed to permit the release of carbon dioxide gas to prevent a build-up of pressure that could rupture the packagings;
 - b) The primary receptacle and the secondary packaging must maintain their integrity at the temperature of the refrigerant used as well as the temperatures and the pressures which could result if refrigeration were lost.
- 10) When packages are placed in an overpack, the package markings required by this packing instruction must either be clearly visible or the markings must be reproduced on the outside of the overpack and the overpack must be marked with the word "Overpack".
- 11) Infectious substances assigned to UN 3373 which are packed and marked in accordance with this packing instruction are not subject to any other requirement in these Instructions except for the following:
 - a) the name and address of the shipper and of the consignee must be provided on each package;
 - b) the name and telephone number of a person responsible must be provided on a written document (such as an air waybill) or on the package;
 - c) classification must be in accordance with 2;6.3.2;
 - d) the incident reporting requirements in 7;4.4 must be met;
 - e) the inspection for damage or leakage requirements in 7;3.1.3 and 7;3.1.4; and
 - f) passengers and crew members are prohibited from transporting infectious substances either as, or in, carry-on baggage or checked baggage or on their person.

Note.— When the shipper or consignee is also the “person responsible” as referred to in b), the name and address need be marked only once in order to satisfy the name and marking provisions in both a) and b).

- 12) Clear instructions on filling and closing such packages must be provided to the shipper or to the person who prepares the package (e.g. patient) by packaging manufacturers and subsequent distributors to enable the package to be correctly prepared for transport.
- 13) Other dangerous goods must not be packed in the same packaging as Division 6.2 infectious substances unless they are necessary for maintaining the viability, stabilizing or preventing degradation or neutralizing the hazards of the infectious substances. A quantity of 30 ml or less of dangerous goods included in Class 3, 8 or 9 may be packed in each primary receptacle containing infectious substances provided these substances meet the requirements of 3;5. When these small quantities of dangerous goods are packed with infectious substances in accordance with this packing instruction no other requirements in these Instructions need be met.

Additional requirements:

- 1) Alternative packagings for the transport of animal material may be authorized by the competent authority in accordance with the provisions of 4;2.8.

Packing Instructions 651 – 655

Passenger aircraft

General requirements

Part 4, Chapter 1 requirements must be met, including:

1) Compatibility requirements

- Substances must be compatible with their packagings as required by 4;1.1.3.
- Metal packagings must be corrosion resistant or be protected against corrosion for substances with a Class 8 subsidiary risk.

2) Closure requirements

- Closures must meet the requirements of 4;1.1.4.

COMBINATION PACKAGINGS					SINGLE PACKAGINGS
<i>Packing instruction</i>	<i>Packing group</i>	<i>Inner packaging (see 6;3.2)</i>	<i>Inner packaging quantity (per receptacle)</i>	<i>Total quantity per package</i>	
651	I	Glass	0.5 L	0.5 L	No
		Plastics	0.5 L		
		Metal	0.5 L		
652	I	Glass	0.5 L	1 L	No
		Plastics	0.5 L		
		Metal	1.0 L		
653	II	Glass	1.0 L	1 L	No
		Plastics	1.0 L		
		Metal	1.0 L		
654	II	Glass	1.0 L	5 L	No
		Plastics	1.0 L		
		Metal	2.5 L		
655	III	Glass	2.5 L	60 L	60 L
		Plastics	2.5 L		
		Metal	5.0 L		

ADDITIONAL PACKING REQUIREMENTS FOR COMBINATION PACKAGINGS*Packing Group I*

- Inner packagings must be packed with sufficient absorbent material to absorb the entire contents of the inner packagings and placed in a rigid leakproof receptacle before packing in outer packagings.

OUTER PACKAGINGS OF COMBINATION PACKAGINGS (see 6;3.1)*Boxes*

Aluminium (4B)
 Fibreboard (4G)
 Natural wood (4C1, 4C2)
 Other metal (4N)
 Plastics (4H1, 4H2)
 Plywood (4D)
 Reconstituted wood (4F)
 Steel (4A)

Drums

Aluminium (1B1, 1B2)
 Fibre (1G)
 Other metal (1N1, 1N2)
 Plastics (1H1, 1H2)
 Plywood (1D)
 Steel (1A1, 1A2)

Jerricans

Aluminium (3B1, 3B2)
 Plastics (3H1, 3H2)
 Steel (3A1, 3A2)

SINGLE PACKAGINGS FOR PACKING GROUP III (PI 655)*Composites*

All (see 6;3.1.18)

Cylinders

See 4;2.7

Drums

Aluminium (1B1, 1B2)
 Other metal (1N1, 1N2)
 Plastics (1H1, 1H2)
 Steel (1A1, 1A2)

Jerricans

Aluminium (3B1, 3B2)
 Plastics (3H1, 3H2)
 Steel (3A1, 3A2)

Packing Instructions 657 – 663

Cargo aircraft only

General requirements

Part 4, Chapter 1 requirements must be met, including:

1) Compatibility requirements

- Substances must be compatible with their packagings as required by 4;1.1.3.
- Metal packagings must be corrosion resistant or be protected against corrosion for substances with a Class 8 subsidiary risk.

2) Closure requirements

- Closures must meet the requirements of 4;1.1.4.

COMBINATION PACKAGINGS					SINGLE PACKAGINGS
<i>Packing instruction</i>	<i>Packing group</i>	<i>Inner packaging (see 6;3.2)</i>	<i>Inner packaging quantity (per receptacle)</i>	<i>Total quantity per package</i>	
657	I	Glass	1.0 L	2.5 L	2.5 L
		Plastics	1.0 L		
		Metal	2.5 L		
658	I	Glass	1.0 L	30 L	30 L
		Plastics	1.0 L		
		Metal	2.5 L		
659	II	Glass	1.0 L	5 L	5 L
		Plastics	1.0 L		
		Metal	2.5 L		
660	II	Glass	1.0 L	30 L	30 L
		Plastics	1.0 L		
		Metal	2.5 L		
661	II	Glass	1.0 L	60 L	60 L
		Plastics	1.0 L		
		Metal	2.5 L		
662	II	Glass	2.5 L	60 L	60 L
		Plastics	2.5 L		
		Metal	5.0 L		
663	III	Glass	5.0 L	220 L	220 L
		Plastics	5.0 L		
		Metal	10.0 L		

ADDITIONAL PACKING REQUIREMENTS FOR COMBINATION PACKAGINGS*Packing Group I*

- Inner packagings must be packed with sufficient absorbent material to absorb the entire contents of the inner packagings and placed in a rigid leakproof receptacle before packing in outer packagings.

OUTER PACKAGINGS OF COMBINATION PACKAGINGS (see 6;3.1)

<i>Boxes</i>	<i>Drums</i>	<i>Jerricans</i>
Aluminium (4B)	Aluminium (1B1, 1B2)	Aluminium (3B1, 3B2)
Fibreboard (4G)	Fibre (1G)	Plastics (3H1, 3H2)
Natural wood (4C1, 4C2)	Other metal (1N1, 1N2)	Steel (3A1, 3A2)
Other metal (4N)	Plastics (1H1, 1H2)	
Plastics (4H1, 4H2)	Plywood (1D)	
Plywood (4D)	Steel (1A1, 1A2)	
Reconstituted wood (4F)		
Steel (4A)		

SINGLE PACKAGINGS FOR PACKING GROUPS I AND II

<i>Composites</i>	<i>Cylinders</i>	<i>Drums</i>	<i>Jerricans</i>
All (see 6;3.1.18)	See 4;2.7	Aluminium (1B1) Other metal (1N1) Plastics (1H1) Steel (1A1)	Aluminium (3B1) Plastics (3H1) Steel (3A1)

SINGLE PACKAGINGS FOR PACKING GROUP III ONLY

<i>Composites</i>	<i>Cylinders</i>	<i>Drums</i>	<i>Jerricans</i>
All (see 6;3.1.18)	See 4;2.7	Aluminium (1B1, 1B2) Other metal (1N1, 1N2) Plastics (1H1, 1H2) Steel (1A1, 1A2)	Aluminium (3B1, 3B2) Plastics (3H1, 3H2) Steel (3A1, 3A2)

Packing Instructions 665 – 670

Passenger aircraft

General requirements

Part 4, Chapter 1 requirements must be met, including:

1) Compatibility requirements

- Substances must be compatible with their packagings as required by 4;1.1.3.
- Metal packagings must be corrosion resistant or be protected against corrosion for substances with a Class 8 subsidiary risk.

2) Closure requirements

- Closures must meet the requirements of 4;1.1.4.

COMBINATION PACKAGINGS					SINGLE PACKAGINGS
<i>Packing instruction</i>	<i>Packing group</i>	<i>Inner packaging (see 6;3.2)</i>	<i>Inner packaging quantity (per receptacle)</i>	<i>Total quantity per package</i>	
665	I	Glass	0.5 kg	1 kg	No
		Plastics	1.0 kg		
		Metal	1.0 kg		
666	I	Glass	0.5 kg	5 kg	No
		Plastics	1.0 kg		
		Metal	1.0 kg		
667	II	Glass	1.0 kg	5 kg	No
		Plastics	2.5 kg		
		Metal	2.5 kg		
		Paper bag	1.0 kg		
		Plastic bag	1.0 kg		
668	II	Glass	1.0 kg	15 kg	No
		Plastics	2.5 kg		
		Metal	2.5 kg		
		Paper bag	1.0 kg		
		Plastic bag	1.0 kg		
669	II	Glass	1.0 kg	25 kg	No
		Plastics	2.5 kg		
		Metal	2.5 kg		
		Paper bag	1.0 kg		
		Plastic bag	1.0 kg		
670	III	Glass	5.0 kg	100 kg	100 kg
		Plastics	10.0 kg		
		Metal	10.0 kg		
		Paper bag	5.0 kg		
		Plastic bag	5.0 kg		
		Fibre	5.0 kg		

OUTER PACKAGINGS OF COMBINATION PACKAGINGS (see 6;3.1)*Boxes*

Aluminium (4B)
 Fibreboard (4G)
 Natural wood (4C1, 4C2)
 Other metal (4N)
 Plastics (4H1, 4H2)
 Plywood (4D)
 Reconstituted wood (4F)
 Steel (4A)

Drums

Aluminium (1B1, 1B2)
 Fibre (1G)
 Other metal (1N1, 1N2)
 Plastics (1H1, 1H2)
 Plywood (1D)
 Steel (1A1, 1A2)

Jerricans

Aluminium (3B1, 3B2)
 Plastics (3H1, 3H2)
 Steel (3A1, 3A2)

ADDITIONAL PACKING REQUIREMENTS FOR SINGLE PACKAGINGS

Fibre, fibreboard, wood and plywood single packagings must be fitted with a suitable liner.

SINGLE PACKAGINGS FOR PACKING GROUP III (PI 670)*Bags*

Paper (5M2)
 Plastic film (5H4)
 Textile (5L3)
 Woven plastics
 (5H3)

Boxes

Aluminium (4B)
 Fibreboard (4G)
 Natural wood (4C2)
 Other metal (4N)
 Plastics (4H2)
 Plywood (4D)
 Reconstituted wood
 (4F)
 Steel (4A)

Composites

All (see
 6;3.1.18)

Cylinders

See 4;2.7

Drums

Aluminium (1B1,
 1B2)
 Fibre (1G)
 Other metal (1N1,
 1N2)
 Plastics (1H1,
 1H2)
 Plywood (1D)
 Steel (1A1, 1A2)

Jerricans

Aluminium (3B1,
 3B2)
 Plastics (3H1,
 3H2)
 Steel (3A1, 3A2)

Packing Instructions 672 – 677

Cargo aircraft only

General requirements

Part 4, Chapter 1 requirements must be met, including:

1) Compatibility requirements

- Substances must be compatible with their packagings as required by 4;1.1.3.
- Metal packagings must be corrosion resistant or be protected against corrosion for substances with a Class 8 subsidiary risk.

2) Closure requirements

- Closures must meet the requirements of 4;1.1.4.

COMBINATION PACKAGINGS					SINGLE PACKAGINGS
<i>Packing instruction</i>	<i>Packing group</i>	<i>Inner packaging (see 6;3.2)</i>	<i>Inner packaging quantity (per receptacle)</i>	<i>Total quantity per package</i>	
672	I	Glass	1.0 kg	15 kg	15 kg
		Plastics	2.5 kg		
		Metal	2.5 kg		
		Paper bag	1.0 kg		
		Plastic bag	1.0 kg		
		Fibre	1.0 kg		
673	I	Glass	1.0 kg	50 kg	50 kg
		Plastics	2.5 kg		
		Metal	2.5 kg		
		Paper bag	1.0 kg		
		Plastic bag	1.0 kg		
		Fibre	1.0 kg		
674	II	Glass	2.5 kg	25 kg	25 kg
		Plastics	5.0 kg		
		Metal	5.0 kg		
		Paper bag	2.5 kg		
		Plastic bag	2.5 kg		
		Fibre	2.5 kg		
675	II	Glass	2.5 kg	50 kg	50 kg
		Plastics	5.0 kg		
		Metal	5.0 kg		
		Paper bag	2.5 kg		
		Plastic bag	2.5 kg		
		Fibre	2.5 kg		
676	II	Glass	2.5 kg	100 kg	100 kg
		Plastics	5.0 kg		
		Metal	5.0 kg		
		Paper bag	2.5 kg		
		Plastic bag	2.5 kg		
		Fibre	2.5 kg		
677	III	Glass	5.0 kg	200 kg	200 kg
		Plastics	10.0 kg		
		Metal	10.0 kg		
		Paper bag	5.0 kg		
		Plastic bag	5.0 kg		
		Fibre	5.0 kg		

OUTER PACKAGINGS OF COMBINATION PACKAGINGS (see 6;3.1)

<i>Boxes</i>	<i>Drums</i>	<i>Jerricans</i>
Aluminium (4B) Fibreboard (4G) Natural wood (4C1, 4C2) Other metal (4N) Plastics (4H1, 4H2) Plywood (4D) Reconstituted wood (4F) Steel (4A)	Aluminium (1B1, 1B2) Fibre (1G) Other metal (1N1, 1N2) Plastics (1H1, 1H2) Steel (1A1, 1A2)	Aluminium (3B1, 3B2) Plastics (3H1, 3H2) Steel (3A1, 3A2)

ADDITIONAL PACKING REQUIREMENTS FOR SINGLE PACKAGINGS

Fibre, fibreboard, wood and plywood single packagings must be fitted with a suitable liner.

SINGLE PACKAGINGS FOR PACKING GROUP I

<i>Composites</i>	<i>Cylinders</i>	<i>Drums</i>	<i>Jerricans</i>
All (see 6;3.1.18)	See 4;2.7	Aluminium (1B1, 1B2) Fibre (1G) Other metal (1N1, 1N2) Plastics (1H1, 1H2) Plywood (1D) Steel (1A1, 1A2)	Aluminium (3B1, 3B2) Plastics (3H1, 3H2) Steel (3A1, 3A2)

SINGLE PACKAGINGS FOR PACKING GROUPS II AND III ONLY

<i>Boxes</i>	<i>Composites</i>	<i>Cylinders</i>	<i>Drums</i>	<i>Jerricans</i>
Aluminium (4B) Fibreboard (4G) Natural wood (4C2) Other metal (4N) Plastics (4H2) Plywood (4D) Reconstituted wood (4F) Plastics (4H2) Steel (4A)	All (see 6;3.1.18)	See 4;2.7	Aluminium (1B1, 1B2) Fibre (1G) Other metal (1N1, 1N2) Plastics (1H1, 1H2) Plywood (1D) Steel (1A1, 1A2)	Aluminium (3B1, 3B2) Plastics (3H1, 3H2) Steel (3A1, 3A2)

SINGLE PACKAGINGS FOR PACKING GROUP III (PI 677 only)

<i>Bags</i>	<i>Boxes</i>	<i>Composites</i>	<i>Cylinders</i>	<i>Drums</i>	<i>Jerricans</i>
Paper (5M2) Plastic film (5H4) Textile (5L3) Woven plastics (5H3)	Aluminium (4B) Fibreboard (4G) Natural wood (4C2) Other metal (4N) Plastics (4H2) Plywood (4D) Reconstituted wood (4F) Steel (4A)	All (see 6;3.1.18)	See 4;2.7	Aluminium (1B1, 1B2) Fibre (1G) Other metal (1N1, 1N2) Plastics (1H1, 1H2) Plywood (1D) Steel (1A1, 1A2)	Aluminium (3B1, 3B2) Plastics (3H1, 3H2) Steel (3A1, 3A2)

Packing Instruction 679

Cargo aircraft only for UN 1700, 2016 and 2017 only

General requirements

Part 4, Chapter 1 requirements must be met, including:

1) Compatibility requirements

- Substances must be compatible with their packagings as required by 4;1.1.3.

2) Closure requirements

- Closures must meet the requirements of 4;1.1.4.

COMBINATION PACKAGINGS			SINGLE PACKAGINGS
<i>UN number and proper shipping name</i>	<i>Packing conditions</i>	<i>Maximum net quantity per package</i>	
UN 1700 Tear gas candles	Elements must not be assembled in grenades or devices, but must be packed in a separate wooden (4C1, 4C2) box and so cushioned that they cannot come into contact with each other or with the walls of the packaging during transport. Not more than 24 grenades and 24 functioning devices per package are permitted.	50 kg	No
UN 2016 Ammunition, toxic, non-explosive	Without ignition elements, bursting charges, detonating fuses or other explosive components.	75 kg	No
UN 2017 Ammunition, tear-producing, non-explosive	Without ignition elements, bursting charges, detonating fuses or other explosive components.	50 kg	No

ADDITIONAL PACKING REQUIREMENTS FOR COMBINATION PACKAGINGS

- Packagings must meet the Packing Group II performance requirements.
- The articles must be individually packaged and separated from each other using partitions, dividers, inner packagings or cushioning material to prevent inadvertent discharge during normal conditions of transport.

OUTER PACKAGINGS OF COMBINATION PACKAGINGS (see 6;3.1)

Boxes

Aluminium (4B)
Fibreboard (4G)
Natural wood (4C1, 4C2)
Other metal (4N)
Plastics (4H2)
Plywood (4D)
Reconstituted wood (4F)
Steel (4A)

Drums

Aluminium (1B1, 1B2)
Fibre (1G)
Other metal (1N1, 1N2)
Plastics (1H1, 1H2)
Plywood (1D)
Steel (1A1, 1A2)

Packing Instruction 680

Passenger and cargo aircraft for UN 1888 only

General requirements

Part 4, Chapter 1 requirements must be met, including:

1) Compatibility requirements

- Substances must be compatible with their packagings as required by 4;1.1.3.

2) Closure requirements

- Closures must meet the requirements of 4;1.1.4.

COMBINATION PACKAGINGS						SINGLE PACKAGINGS	
<i>UN number and proper shipping name</i>	<i>Inner packaging (see 6;3.2)</i>	<i>Inner packaging quantity (per receptacle) — passenger</i>	<i>Inner packaging quantity (per receptacle) — cargo</i>	<i>Total quantity per package — passenger</i>	<i>Total quantity per package — cargo</i>	<i>Passenger</i>	<i>Cargo</i>
UN 1888 Chloroform	Glass	1.0 L	2.5 L	60 L	220 L	No	220 L
	Plastics	1.0 L	2.5 L				
	Metal	2.5 L	5.0 L				

ADDITIONAL PACKING REQUIREMENTS FOR COMBINATION PACKAGINGS

- Inner packagings must be packed with sufficient absorbent material to absorb the entire contents of the inner packagings and placed in a rigid leakproof receptacle before packing in outer packagings.

OUTER PACKAGINGS OF COMBINATION PACKAGINGS (see 6;3.1)

Boxes

Aluminium (4B)
Fibreboard (4G)
Natural wood (4C1, 4C2)
Other metal (4N)
Plastics (4H1, 4H2)
Plywood (4D)
Reconstituted wood (4F)
Steel (4A)

Drums

Aluminium (1B1, 1B2)
Fibre (1G)
Other metal (1N1, 1N2)
Plastics (1H1, 1H2)
Steel (1A1, 1A2)

Jerricans

Aluminium (3B1, 3B2)
Plastics (3H1, 3H2)
Steel (3A1, 3A2)

SINGLE PACKAGINGS FOR CARGO AIRCRAFT ONLY

Composites

All (see 6;3.1.18)

Cylinders

See 4;2.7

Drums

Aluminium (1B1, 1B2)
Other metal (1N1, 1N2)
Plastics (1H1, 1H2)
Steel (1A1, 1A2)

Jerricans

Aluminium (3B1, 3B2)
Plastics (3H1, 3H2)
Steel (3A1, 3A2)

Packing Instruction Y680

Limited quantities
Passenger and cargo aircraft for UN 1888 only

General requirements

Part 4, Chapter 1 requirements must be met (except that 4;1.1.2, 1.1.9 c), 1.1.9 e), 1.1.16, 1.1.18 and 1.1.20 do not apply), including:

1) Compatibility requirements

- Substances must be compatible with their packagings as required by 4;1.1.3.

2) Closure requirements

- Closures must meet the requirements of 4;1.1.4.

3) Limited quantity requirements

- Part 3, Chapter 4 requirements must be met including:
 - the capability of the package to pass a 1.2 m drop test;
 - a 24-hour stacking test; and
 - inner packagings for liquids must be capable of passing a pressure differential test (4;1.1.6).

COMBINATION PACKAGINGS						SINGLE PACKAGINGS
<i>UN number and proper shipping name</i>	<i>Packing group</i>	<i>Inner packaging (see 6;3.2)</i>	<i>Inner packaging quantity (per receptacle)</i>	<i>Total quantity per package</i>	<i>Total gross mass per package</i>	
UN 1888 Chloroform	III	Glass	0.1 L	2 L	30 kg	No
		Plastics	0.1 L			
		Metal	0.1 L			

OUTER PACKAGINGS OF COMBINATION PACKAGINGS (see 6;3.1)

Boxes

Aluminium
Fibreboard
Natural wood
Other metal
Plastics
Plywood
Reconstituted wood
Steel

Drums

Aluminium
Fibre
Other metal
Plastics
Steel

Jerricans

Aluminium
Plastics
Steel

ADDITIONAL PACKING REQUIREMENTS FOR COMBINATION PACKAGINGS

- Inner packagings must be packed with sufficient absorbent material to absorb the entire contents of the inner packagings and placed in a rigid leakproof receptacle before packing in outer packagings.

Packing Instruction 681

Cargo aircraft only for Chlorosilanes

General requirements

Part 4, Chapter 1 requirements must be met, including:

1) Compatibility requirements

- Substances must be compatible with their packagings as required by 4;1.1.3.
- Metal packagings must be corrosion resistant or be protected against corrosion.

2) Closure requirements

- Closures must meet the requirements of 4;1.1.4.

COMBINATION PACKAGINGS				SINGLE PACKAGINGS
UN number	Inner packaging (see 6;3.2)	Net quantity per inner packaging	Total quantity per package	
UN 3361, UN 3362	Glass	1.0 L	30.0 L	30.0 L
	Plastics	Forbidden		
	Steel	5.0 L		

OUTER PACKAGINGS OF COMBINATION PACKAGINGS

Boxes

Fibreboard (4G)
Natural wood (4C1, 4C2)
Plastics (4H1, 4H2)
Plywood (4D)
Reconstituted wood (4F)
Steel (4A)

Drums

Fibre (1G)
Plastics (1H1, 1H2)
Plywood (1D)
Steel (1A1, 1A2)

SINGLE PACKAGINGS

Composites

Plastic receptacle in steel drum (6HA1)

Cylinders

Steel (as permitted by 4;2.7)

Drums

Steel (1A1)

Jerricans

Steel (3A1)

Packing Instruction 699

Passenger and cargo aircraft for UN 3123 and UN 3125 only

Only packagings which are approved by the appropriate national authority for these substances may be used (see 4;2.8). A copy of this approval must accompany each consignment or an annotation that it has been granted must be included with the transport document.

Chapter 9

CLASS 7 — RADIOACTIVE MATERIAL

Parts of this Chapter are affected by State Variations CA 1, CA 2, CA 4, IR 4, JP 2, JP 17; see Table A-1

9.1 GENERAL

9.1.1 Radioactive material, packagings and packages must meet the requirements of 6;7. The quantity of radioactive material in a package must not exceed the limits specified in 2;7.2.4. The types of packages for radioactive materials covered by these Instructions are:

- a) Excepted package (see 1;6.1.5);
- b) Industrial package Type 1 (Type IP-1 package);
- c) Industrial package Type 2 (Type IP-2 package);
- d) Industrial package Type 3 (Type IP-3 package);
- e) Type A package;
- f) Type B(U) package;
- g) Type B(M) package;
- h) Type C package.

Packages containing fissile material or uranium hexafluoride are subject to additional requirements.

9.1.2 The non-fixed contamination on the external surfaces of any package must be kept as low as practicable and, under routine conditions of transport, must not exceed the following limits:

- a) 4 Bq/cm² for beta and gamma emitters and low toxicity alpha emitters; and
- b) 0.4 Bq/cm² for all other alpha emitters.

These limits are applicable when averaged over any area of 300 cm² of any part of the surface.

≠ 9.1.3 A package must not contain any other items except such articles and documents as are necessary for the use of the radioactive material. This requirement must not preclude the transport of low specific activity material or surface contaminated objects with other items. The transport of such articles and documents in a package, or of low specific activity material or surface contaminated objects with other items may be permitted provided that there is no interaction between them and the packaging or its radioactive contents that would reduce the safety of the package.

9.1.4 Except as provided in 7;3.2.5, the level of non-fixed contamination on the external and internal surfaces of overpacks and freight containers, must not exceed the limits specified in 9.1.2.

9.1.5 Radioactive material meeting the criteria of other Classes or Divisions as defined in Part 2 must be allocated to Packing Group I, II or III, as appropriate, by the application of the grouping criteria provided in Part 2 corresponding to the nature of the predominant subsidiary risk. It must also be capable of meeting the appropriate packaging performance criteria for the subsidiary risk.

≠ 9.1.6 Before a packaging is first used to transport radioactive material, it must be confirmed that it has been manufactured in conformity with the design specifications to ensure compliance with the relevant provisions of these Instructions and any applicable certificate of approval. The following requirements must also be fulfilled, if applicable:

- ≠ a) If the design pressure of the containment system exceeds 35 kPa (gauge), it must be ensured that the containment system of each packaging conforms to the approved design requirements relating to the capability of that system to maintain its integrity under that pressure;

- ≠ b) For each packaging intended for use as a Type B(U), Type B(M) and Type C package and for each packaging intended to contain fissile material, it must be ensured that the effectiveness of its shielding and containment and, where necessary, the heat transfer characteristics and the effectiveness of the confinement system, are within the limits applicable to or specified for the approved design;
- ≠ c) For each packaging intended to contain fissile material, it must be ensured that the effectiveness of the criticality safety features is within the limits applicable to or specified for the design and in particular where, in order to comply with the requirements of 6;7.10.1 neutron poisons are specifically included, checks must be performed to confirm the presence and distribution of those neutron poisons.
- + 9.1.7 Before each shipment of any package, it must be ensured that the package does not contain:
 - a) radionuclides different from those specified for the package design; or
 - b) contents in a form, or physical or chemical state different from those specified for the package design.
- ≠ 9.1.8 Before each shipment of any package, it must be ensured that all the requirements specified in the relevant provisions of these Instructions and in the applicable certificates of approval have been fulfilled. The following requirements must also be fulfilled, if applicable:
 - > ≠ a) It must be ensured that lifting attachments which do not meet the requirements of 6;7.1.2 have been removed or otherwise rendered incapable of being used for lifting the package, in accordance with 6;7.1.3;
 - > ≠ b) Each Type B(U), Type B(M) and Type C package must be held until equilibrium conditions have been approached closely enough to demonstrate compliance with the requirements for temperature and pressure unless an exemption from these requirements has received unilateral approval;
 - > ≠ c) For each Type B(U), Type B(M) and Type C package, it must be ensured by inspection and/or appropriate tests that all closures, valves, and other openings of the containment system through which the radioactive contents might escape are properly closed and, where appropriate, sealed in the manner for which the demonstrations of compliance with the requirements of 6;7.7.8 and 6;7.9.3 were made;
 - > ≠ d) For packages containing fissile material, the measurement specified in 6;7.10.5 b) and the tests to demonstrate closure of each package as specified in 6;7.10.8 must be performed.
- ≠ 9.1.9 The shipper must also have a copy of any instructions with regard to the proper closing of the package and any preparation for shipment before making any shipment under the terms of the certificates.
- ≠ 9.1.10 Except for consignments under exclusive use, the transport index of any package or overpack must not exceed 10, nor must the criticality safety index of any package or overpack exceed 50.
- ≠ 9.1.11 Except for packages or overpacks transported under exclusive use and special arrangement under the conditions specified in 7;2.10.5.3, the maximum radiation level at any point on any external surface of a package or overpack must not exceed 2 mSv/h.
- ≠ 9.1.12 The maximum radiation level at any point on any external surface of a package or overpack under exclusive use must not exceed 10 mSv/h.

9.2 REQUIREMENTS AND CONTROLS FOR TRANSPORT OF LSA MATERIAL AND SCO

- 9.2.1 The quantity of LSA material or SCO in a single Industrial package Type 1 (Type IP-1), Industrial package Type 2 (Type IP-2), or Industrial package Type 3 (Type IP-3), must be so restricted that the external radiation level at 3 m from the unshielded material does not exceed 10 mSv/h.
- ≠ 9.2.2 LSA material and SCO which are or contain fissile material, which is not excepted under 2;7.2.3.5, must meet the applicable requirements in 7;2.9.4.1 and 7;2.9.4.2.
- + 9.2.3 LSA material and SCO which are or contain fissile material must meet the applicable requirements of 6;7.10.1.
- ≠ 9.2.4 LSA-I material, SCO-I and fissile material must not be transported unpackaged.
- ≠ 9.2.5 LSA material and SCO must be packaged in accordance with Table 4-2.

9.3 PACKAGES CONTAINING FISSILE MATERIAL

≠ The contents of packages containing fissile material must be as specified for the package design either directly in these Instructions or in the certificate of approval.

Table 4-2. Industrial package requirements for LSA material and SCO

<i>Radioactive contents</i>	<i>Industrial package type</i>	
	<i>Exclusive use</i>	<i>Not under exclusive use</i>
LSA-I Solid Liquid	Type IP-1 Type IP-1	Type IP-1 Type IP-2
LSA-II Solid Liquid and gas	Type IP-2 Type IP-2	Type IP-2 Type IP-3
LSA-III	Type IP-2	Type IP-3
SCO-I	Type IP-1	Type IP-1
SCO-II	Type IP-2	Type IP-2

Chapter 10

CLASS 8 — CORROSIVE SUBSTANCES

10.1 PACKING INSTRUCTIONS

Packing Instructions Y840 – Y841

Limited quantities
Passenger and cargo aircraft

General requirements

Part 4, Chapter 1 requirements must be met (except that 4;1.1.2, 1.1.9 c), 1.1.9 e), 1.1.16, 1.1.18 and 1.1.20 do not apply), including:

1) Compatibility requirements

- Substances must be compatible with their packagings as required by 4;1.1.3.
- Metal packagings must be corrosion resistant or be protected against corrosion.
- Substances of Class 8 are permitted in glass or earthenware inner packagings only if the substance is free from hydrofluoric acid.

2) Closure requirements

- Closures must meet the requirements of 4;1.1.4.

3) Limited quantity requirements

- Part 3, Chapter 4 requirements must be met including:
 - the capability of the package to pass a 1.2 m drop test;
 - a 24-hour stacking test; and
 - inner packagings for liquids must be capable of passing a pressure differential test (4;1.1.6).

COMBINATION PACKAGINGS						SINGLE PACKAGINGS
Packing instruction	Packing group	Inner packaging (see 6;3.2)	Inner packaging quantity (per receptacle)	Total quantity per package	Total gross mass per package	
Y840	II	Glass	0.1L	0.5 L	30 kg	No
		Plastics	0.1L			
		Metal	0.1L			
Y841	III	Glass	0.5 L	1.0 L		No
		Plastics	0.5 L			
		Metal	0.5 L			

ADDITIONAL PACKING REQUIREMENTS FOR COMBINATION PACKAGINGS

Packing Group II

- Glass inner packagings must be packed with sufficient absorbent material to absorb the entire contents of the inner packagings and placed in a compatible and rigid intermediate packaging before packing in outer packagings.

OUTER PACKAGINGS OF COMBINATION PACKAGINGS (see 6;3.1)*Boxes*

Aluminium
Fibreboard
Natural wood
Other metal
Plastics
Plywood
Reconstituted wood
Steel

Drums

Aluminium
Fibre
Other metal
Plastics
Steel

Jerricans

Aluminium
Plastics
Steel

Packing Instructions Y843 – Y845

Limited quantities
Passenger and cargo aircraft

General requirements

Part 4, Chapter 1 requirements must be met (except that 4;1.1.2, 1.1.9 c), 1.1.9 e), 1.1.16, 1.1.18 and 1.1.20 do not apply), including:

1) Compatibility requirements

- Substances must be compatible with their packagings as required by 4;1.1.3.
- Metal packagings must be corrosion resistant or be protected against corrosion.
- Substances of Class 8 are permitted in glass or earthenware inner packagings only if the substance is free from hydrofluoric acid.

2) Closure requirements

- Closures must meet the requirements of 4;1.1.4.

3) Limited quantity requirements

- Part 3, Chapter 4 requirements must be met including:
 - the capability of the package to pass a 1.2 m drop test; and
 - a 24-hour stacking test.

COMBINATION PACKAGINGS						SINGLE PACKAGINGS
<i>Packing instruction</i>	<i>Packing group</i>	<i>Inner packaging (see 6;3.2)</i>	<i>Inner packaging quantity (per receptacle)</i>	<i>Total quantity per package</i>	<i>Total gross mass per package</i>	
Y843	II	Glass	0.5 kg	1 kg	30 kg	No
		Plastics	0.5 kg			
		Metal	0.5 kg			
		Plastic bag	0.5 kg			
Y844	II	Glass	0.5 kg	5 kg	30 kg	No
		Plastics	0.5 kg			
		Metal	0.5 kg			
		Plastic bag	0.5 kg			
Y845	III	Glass	1.0 kg	5 kg	30 kg	No
		Plastics	1.0 kg			
		Metal	1.0 kg			
		Plastic bag	1.0 kg			

OUTER PACKAGINGS OF COMBINATION PACKAGINGS (see 6;3.1)*Boxes*

Aluminium
Fibreboard
Natural wood
Other metal
Plastics
Plywood
Reconstituted wood
Steel

Drums

Aluminium
Fibre
Other metal
Plastics
Steel

Jerricans

Aluminium
Plastics
Steel

Packing Instructions 850 – 852

Passenger aircraft

General requirements

Part 4, Chapter 1 requirements must be met, including:

1) Compatibility requirements

- Substances must be compatible with their packagings as required by 4;1.1.3.
- Metal packagings must be corrosion resistant or be protected against corrosion.
- Substances of Class 8 are permitted in glass or earthenware inner packagings only if the substance is free from hydrofluoric acid.

2) Closure requirements

- Closures must meet the requirements of 4;1.1.4.

COMBINATION PACKAGINGS					SINGLE PACKAGINGS
<i>Packing instruction</i>	<i>Packing group</i>	<i>Inner packaging (see 6;3.2)</i>	<i>Inner packaging quantity (per receptacle)</i>	<i>Total quantity per package</i>	
850	I	Glass	0.5 L	0.5 L	No
		Plastics	0.5 L		
		Metal	0.5 L		
851	II	Glass	1.0 L	1 L	No
		Plastics	1.0 L		
		Metal	1.0 L		
852	III	Glass	2.5 L	5 L	No
		Plastics	2.5 L		
		Metal	5.0 L		

ADDITIONAL PACKING REQUIREMENTS FOR COMBINATION PACKAGINGS*Packing Group I*

- Inner packagings must be packed with sufficient absorbent material to absorb the entire contents of the inner packagings and placed in a rigid leakproof receptacle before packing in outer packagings.

Packing Group III

- Packagings must meet the Packing Group II performance requirements.

OUTER PACKAGINGS OF COMBINATION PACKAGINGS (see 6;3.1)*Boxes*

Aluminium (4B)
 Fibreboard (4G)
 Natural wood (4C1, 4C2)
 Other metal (4N)
 Plastics (4H1, 4H2)
 Plywood (4D)
 Reconstituted wood (4F)
 Steel (4A)

Drums

Aluminium (1B1, 1B2)
 Fibre (1G)
 Other metal (1N1, 1N2)
 Plastics (1H1, 1H2)
 Steel (1A1, 1A2)

Jerricans

Aluminium (3B1, 3B2)
 Plastics (3H1, 3H2)
 Steel (3A1, 3A2)

Packing Instructions 854 – 856

Cargo aircraft only

General requirements

Part 4, Chapter 1 requirements must be met, including:

1) Compatibility requirements

- Substances must be compatible with their packagings as required by 4;1.1.3.
- Metal packagings must be corrosion resistant or be protected against corrosion.
- Substances of Class 8 are permitted in glass or earthenware inner packagings only if the substance is free from hydrofluoric acid.

2) Closure requirements

- Closures must meet the requirements of 4;1.1.4.

COMBINATION PACKAGINGS					SINGLE PACKAGINGS
<i>Packing instruction</i>	<i>Packing group</i>	<i>Inner packaging (see 6;3.2)</i>	<i>Inner packaging quantity (per receptacle)</i>	<i>Total quantity per package</i>	
854	I	Glass	1.0 L	2.5 L	No
		Plastics	1.0 L		
		Metal	1.0 L		
855	II	Glass	2.5 L	30 L	30 L
		Plastics	2.5 L		
		Metal	2.5 L		
856	III	Glass	5.0 L	60 L	60 L
		Plastics	5.0 L		
		Metal	10.0 L		

ADDITIONAL PACKING REQUIREMENTS FOR COMBINATION PACKAGINGS*Packing Group I*

- Inner packagings must be packed with sufficient absorbent material to absorb the entire contents of the inner packagings and placed in a rigid leakproof receptacle before packing in outer packagings.

Packing Group III

- Packagings must meet the Packing Group II performance requirements.

OUTER PACKAGINGS OF COMBINATION PACKAGINGS (see 6;3.1)*Boxes*

Aluminium (4B)
 Fibreboard (4G)
 Natural wood (4C1, 4C2)
 Other metal (4N)
 Plastics (4H1, 4H2)
 Plywood (4D)
 Reconstituted wood (4F)
 Steel (4A)

Drums

Aluminium (1B1, 1B2)
 Fibre (1G)
 Other metal (1N1, 1N2)
 Plastics (1H1, 1H2)
 Steel (1A1, 1A2)

Jerricans

Aluminium (3B1, 3B2)
 Plastics (3H1, 3H2)
 Steel (3A1, 3A2)

SINGLE PACKAGINGS FOR PACKING GROUP III*Composites*

All (see 6;3.1.18)

Cylinders

See 4;2.7

Drums

Aluminium (1B1)
 Other metal (1N1)
 Plastics (1H1)
 Steel (1A1)

Jerricans

Aluminium (3B1)
 Plastics (3H1)
 Steel (3A1)

SINGLE PACKAGINGS FOR PACKING GROUP II ONLY*Composites*

All (see 6;3.1.18)

Cylinders

See 4;2.7

Drums

Aluminium (1B1, 1B2)
 Other metal (1N1, 1N2)
 Plastics (1H1, 1H2)
 Steel (1A1, 1A2)

Jerricans

Aluminium (3B1, 3B2)
 Plastics (3H1, 3H2)
 Steel (3A1, 3A2)

Packing Instructions 858 – 860

Passenger aircraft

General requirements

Part 4, Chapter 1 requirements must be met, including:

1) Compatibility requirements

- Substances must be compatible with their packagings as required by 4;1.1.3.
- Metal packagings must be corrosion resistant or be protected against corrosion.
- Substances of Class 8 are permitted in glass or earthenware inner packagings only if the substance is free from hydrofluoric acid.

2) Closure requirements

- Closures must meet the requirements of 4;1.1.4.

COMBINATION PACKAGINGS					SINGLE PACKAGINGS
<i>Packing instruction</i>	<i>Packing group</i>	<i>Inner packaging (see 6;3.2)</i>	<i>Inner packaging quantity (per receptacle)</i>	<i>Total quantity per package</i>	
858	I	Glass	0.5 kg	1 kg	No
		Plastics	0.5 kg		
		Metal	0.5 kg		
859	II	Glass	1.0 kg	15 kg	No
		Plastics	2.5 kg		
		Metal	2.5 kg		
		Plastic bag	1.0 kg		
860	III	Glass	2.5 kg	25 kg	No
		Plastics	2.5 kg		
		Metal	5.0 kg		
		Plastic bag	2.5 kg		

ADDITIONAL PACKING REQUIREMENTS FOR COMBINATION PACKAGINGS

Packing Group III

- Packagings must meet the Packing Group II performance requirements.

OUTER PACKAGINGS OF COMBINATION PACKAGINGS (see 6;3.1)

Boxes

Aluminium (4B)
Fibreboard (4G)
Natural wood (4C1, 4C2)
Other metal (4N)
Plastics (4H1, 4H2)
Plywood (4D)
Reconstituted wood (4F)
Steel (4A)

Drums

Aluminium (1B1, 1B2)
Fibre (1G)
Other metal (1N1, 1N2)
Plastics (1H1, 1H2)
Plywood (1D)
Steel (1A1, 1A2)

Jerricans

Aluminium (3B1, 3B2)
Plastics (3H1, 3H2)
Steel (3A1, 3A2)

Packing Instructions 862 – 864

Cargo aircraft only

General requirements

Part 4, Chapter 1 requirements must be met, including:

1) Compatibility requirements

- Substances must be compatible with their packagings as required by 4;1.1.3.
- Metal packagings must be corrosion resistant or be protected against corrosion.
- Substances of Class 8 are permitted in glass or earthenware inner packagings only if the substance is free from hydrofluoric acid.

2) Closure requirements

- Closures must meet the requirements of 4;1.1.4.

COMBINATION PACKAGINGS					SINGLE PACKAGINGS
<i>Packing instruction</i>	<i>Packing group</i>	<i>Inner packaging (see 6;3.2)</i>	<i>Inner packaging quantity (per receptacle)</i>	<i>Total quantity per package</i>	
862	I	Glass	1.0 kg	25 kg	25 kg
		Plastics	2.5 kg		
		Metal	2.5 kg		
863	II	Glass	2.5 kg	50 kg	50 kg
		Plastics	5.0 kg		
		Metal	5.0 kg		
		Plastic bag	2.5 kg		
864	III	Glass	5.0 kg	100 kg	100 kg
		Plastics	5.0 kg		
		Metal	10.0 kg		
		Plastic bag	5.0 kg		

ADDITIONAL PACKING REQUIREMENTS FOR COMBINATION PACKAGINGS

Packing Group III

- Packagings must meet the Packing Group II performance requirements.

OUTER PACKAGINGS OF COMBINATION PACKAGINGS (see 6;3.1)

Boxes

Aluminium (4B)
Fibreboard (4G)
Natural wood (4C1, 4C2)
Other metal (4N)
Plastics (4H1, 4H2)
Plywood (4D)
Reconstituted wood (4F)
Steel (4A)

Drums

Aluminium (1B1, 1B2)
Fibre (1G)
Other metal (1N1, 1N2)
Plastics (1H1, 1H2)
Plywood (1D)
Steel (1A1, 1A2)

Jerricans

Aluminium (3B1, 3B2)
Plastics (3H1, 3H2)
Steel (3A1, 3A2)

ADDITIONAL PACKING REQUIREMENTS FOR SINGLE PACKAGINGS

- Fibre, fibreboard, wood and plywood single packagings must be fitted with a suitable liner.

SINGLE PACKAGINGS FOR PACKING GROUP I

<i>Composites</i>	<i>Cylinders</i>	<i>Drums</i>	<i>Jerricans</i>
All (see 6;3.1.18)	See 4;2.7	Aluminium (1B1, 1B2) Fibre (1G) Plastics (1H1, 1H2) Plywood (1D) Steel (1A1, 1A2)	Aluminium (3B1, 3B2) Plastics (3H1, 3H2) Steel (3A1, 3A2)

SINGLE PACKAGINGS FOR PACKING GROUPS II AND III ONLY

<i>Boxes</i>	<i>Composites</i>	<i>Cylinders</i>	<i>Drums</i>	<i>Jerricans</i>
Aluminium (4B) Fibreboard (4G) Natural wood (4C2) Other metal (4N) Plastics (4H2) Plywood (4D) Reconstituted wood (4F) Steel (4A)	All (see 6;3.1.18)	See 4;2.7	Aluminium (1B1, 1B2) Fibre (1G) Plastics (1H1, 1H2) Plywood (1D) Steel (1A1, 1A2)	Aluminium (3B1, 3B2) Plastics (3H1, 3H2) Steel (3A1, 3A2)

Packing Instruction 866

Cargo aircraft only for UN 2028 only

General requirements

Part 4, Chapter 1 requirements must be met, including:

1) Compatibility requirements

- Substances must be compatible with their packagings as required by 4;1.1.3.
- Metal packagings must be corrosion resistant or be protected against corrosion.

2) Closure requirements

- Closures must meet the requirements of 4;1.1.4.

COMBINATION PACKAGINGS				SINGLE PACKAGINGS
<i>UN number and proper shipping name</i>	<i>Packing conditions</i>	<i>Total quantity per package — passenger</i>	<i>Total quantity per package — cargo</i>	
UN 2028 Bombs, smoke, non-explosive with corrosive liquid, without initiating device	Bombs, smoke may be carried provided they are without ignition elements, bursting charges, detonating fuses or other explosive components.	Forbidden	50 kg	No

ADDITIONAL PACKING REQUIREMENTS FOR COMBINATION PACKAGINGS

- The articles must be individually packaged and separated from each other using partitions, dividers, inner packagings or cushioning material.

OUTER PACKAGINGS OF COMBINATION PACKAGINGS (see 6;3.1)

<i>Boxes</i>	<i>Drums</i>
Aluminium (4B)	Aluminium (1B2)
Fibreboard (4G)	Fibre (1G)
Natural wood (4C1, 4C2)	Other metal (1N2)
Other metal (4N)	Plastics (1H2)
Plastics (4H1, 4H2)	Steel (1A2)
Plywood (4D)	
Reconstituted wood (4F)	
Steel (4A)	

Packing Instruction 867

Passenger and cargo aircraft for UN 2803 only

General requirements

Part 4, Chapter 1 requirements must be met, including:

1) Compatibility requirements

- Substances must be compatible with their packagings as required by 4;1.1.3.
- Metal packagings must be corrosion resistant or be protected against corrosion.

2) Closure requirements

- Closures must meet the requirements of 4;1.1.4.

COMBINATION PACKAGINGS					SINGLE PACKAGINGS
<i>UN number and proper shipping name</i>	<i>Inner packaging (see 6;3.2)</i>	<i>Inner packaging quantity (per receptacle)</i>	<i>Total quantity per package — passenger</i>	<i>Total quantity per package — cargo</i>	
UN 2803 Gallium	Plastics	3.5 kg	20 kg	20 kg	No

ADDITIONAL PACKING REQUIREMENTS FOR COMBINATION PACKAGINGS

- Packagings must meet the Packing Group I performance requirements.
- Plastic inner packagings must be enclosed in liners or bags of strong leakproof and puncture resistant material impervious to the contents and completely surrounding the contents to prevent it from escaping from a package irrespective of its position or orientation.
- Plastic inner packagings must be packed with sufficient cushioning material to prevent breakage.

OUTER PACKAGINGS OF COMBINATION PACKAGINGS (see 6;3.1)

<i>Boxes</i>	<i>Drums</i>
Fibreboard (4G)	Fibre (1G)
Natural wood (4C1, 4C2)	Other metal (1N1, 1N2)
Other metal (4N)	Plastics (1H1, 1H2)
Plastics (4H1, 4H2)	Steel (1A1, 1A2)
Plywood (4D)	
Reconstituted wood (4F)	
Steel (4A)	

CARRIAGE AT LOW TEMPERATURES

When it is necessary to transport Gallium at low temperatures in order to maintain it in a completely solid state, packagings may be overpacked in strong water-resistant outer packagings which contain dry ice or other means of refrigeration. If a refrigerant is used, all of the above materials used in the packaging of gallium must be chemically and physically resistant at the low temperatures of the refrigerant employed. If dry ice is used, the outer packaging must permit the release of carbon dioxide gas.

Packing Instruction 868

Passenger and cargo aircraft for UN 2809 only

General requirements

Part 4, Chapter 1 requirements must be met, including:

1) Compatibility requirements

- Substances must be compatible with their packagings as required by 4;1.1.3.
- Metal packagings must be corrosion resistant or be protected against corrosion.

2) Closure requirements

- Closures must meet the requirements of 4;1.1.4.

COMBINATION PACKAGINGS					SINGLE PACKAGINGS
<i>UN number and proper shipping name</i>	<i>Inner packaging (see 6;3.2)</i>	<i>Inner packaging quantity (per receptacle)</i>	<i>Total quantity per package — passenger</i>	<i>Total quantity per package — cargo</i>	
UN 2809 Mercury	Glass	2.5 kg	35 kg	35 kg	See below
	Plastics	2.5 kg			

ADDITIONAL PACKING REQUIREMENTS FOR COMBINATION PACKAGINGS

- Packagings must meet the Packing Group I performance requirements.
- Inner packagings must be enclosed in liners or bags of strong leakproof and puncture resistant material impervious to the contents and completely surrounding the contents to prevent it from escaping from a package irrespective of its position or orientation.
- Inner packagings must be packed with sufficient cushioning material to prevent breakage.

OUTER PACKAGINGS OF COMBINATION PACKAGINGS (see 6;3.1)

Boxes

Fibreboard (4G)
Natural wood (4C1, 4C2)
Other metal (4N)
Plastics (4H1, 4H2)
Plywood (4D)
Reconstituted wood (4F)
Steel (4A)

Drums

Fibre (1G)
Other metal (1N1, 1N2)
Plastics (1H1, 1H2)
Steel (1A1, 1A2)

SINGLE PACKAGINGS

Mercury may also be packed in a single packaging which may only be a welded steel bottle with an inner vaulted bottom, an opening not exceeding 20 mm and a closure which must be a bolt with a conical thread.

Packing Instruction 869

Passenger and cargo aircraft for UN 3506 only

General requirements

Part 4, Chapter 1 requirements must be met, including:

1) Compatibility requirements

- Substances must be compatible with their packagings as required by 4;1.1.3.
- Metal packagings must be corrosion resistant or be protected against corrosion.

2) Closure requirements

- Closures must meet the requirements of 4;1.1.4.

COMBINATION PACKAGINGS			SINGLE PACKAGINGS
<i>UN number and proper shipping name</i>	<i>Net quantity* per package — passenger</i>	<i>Net quantity* per package — cargo</i>	
UN 3506 Mercury contained in manufactured articles	No limit	No limit	No

*For the purposes of Part 5;4.1.5.1 the “net quantity” shown on the dangerous goods transport document is the net mass of the manufactured articles in each package.

ADDITIONAL PACKING REQUIREMENTS

- Manufactured articles or apparatuses of which metallic mercury is a component part, such as manometers, pumps, thermometers, and switches must be packed in sealed inner liners or bags of strong leakproof and puncture-resistant material impervious to mercury which will prevent the escape of mercury from the package irrespective of its position before being packed in outer packagings.

Note.— Mercury switches and relays are excepted from the requirement for a sealed inner liner or bag providing they are of the totally enclosed leakproof type in sealed metal or plastic units.

- Electron tubes, mercury vapour tubes (tubes with less than a total net quantity of 450 g of mercury) must be packed in strong outer packagings with all seams and joints sealed with self-adhesive, pressure-sensitive tape which will prevent the escape of mercury from the package.

Note.— Tubes with 450 g of mercury or more must be packaged according to the requirements for manufactured articles or apparatuses (above).

- Electron tubes which are packed in sealed leakproof metal cases may be shipped in the manufacturer’s original packagings.

OUTER PACKAGINGS OF COMBINATION PACKAGINGS (see 6;3.1)

Boxes

Drums

Jerricans

Strong outer packagings

Packing Instruction 870

Passenger and cargo aircraft for UN 2794 and 2795 only

General requirements

Part 4, Chapter 1 requirements must be met, including:

1) Compatibility requirements

- Substances must be compatible with their packagings as required by 4;1.1.3.
- Metal packagings must be corrosion resistant or be protected against corrosion.

2) Closure requirements

- Closures must meet the requirements of 4;1.1.4.

COMBINATION PACKAGINGS				SINGLE PACKAGINGS
<i>UN number and proper shipping name</i>	<i>Packing conditions</i>	<i>Total quantity per package — passenger</i>	<i>Total quantity per package — cargo</i>	
UN 2794 Batteries, wet, filled with acid UN 2795 Batteries, wet, filled with alkali	Batteries must be placed in an acid/alkali-proof liner of sufficient strength and adequately sealed to positively preclude leakage in the event of spillage. The batteries must be packed so that the fill openings and vents, if any, are upward; they must be incapable of short-circuiting and be securely cushioned in the packagings. The upright position of the package must be indicated on it by "Package orientation" labels (Figure 5-27) as required by 5;3. The words "This side up" or "This end up" may also be displayed on the top of the package. <i>Batteries installed in equipment</i> If batteries are shipped as an integral component of assembled equipment, they must be securely installed and fastened in an upright position and protected against contact with other articles so as to prevent short circuits. Batteries must be removed and packed according to this packing instruction if the assembled equipment is likely to be carried in other than an upright position.	30 kg	No limit	Unpackaged batteries No

ADDITIONAL PACKING REQUIREMENTS FOR COMBINATION PACKAGINGS

- Packagings must meet the Packing Group II performance requirements.
- For batteries, electric storage, packed with battery fluid in the same outer packaging, see UN 2796 and UN 2797.

OUTER PACKAGINGS OF COMBINATION PACKAGINGS (see 6;3.1)

Boxes

Aluminium (4B)
Fibreboard (4G)
Natural wood (4C1, 4C2)
Plastics (4H1, 4H2)
Plywood (4D)
Reconstituted wood (4F)
Steel (4A)

Drums

Aluminium (1B2)
Fibre (1G)
Other metal (1N2)
Plastics (1H2)
Steel (1A2)

Jerricans

Aluminium (3B2)
Plastics (3H2)
Steel (3A2)

Packing Instruction 871

Passenger and cargo aircraft for UN 3028 only

General requirements

Part 4, Chapter 1 requirements must be met, including:

1) Compatibility requirements

- Substances must be compatible with their packagings as required by 4;1.1.3.
- Metal packagings must be corrosion resistant or be protected against corrosion.

2) Closure requirements

- Closures must meet the requirements of 4;1.1.4.

COMBINATION PACKAGINGS				SINGLE PACKAGINGS
<i>UN number and proper shipping name</i>	<i>Packing conditions</i>	<i>Total quantity per package — passenger</i>	<i>Total quantity per package — cargo</i>	
UN 3028 Batteries, dry, containing potassium hydroxide solid	The batteries must be securely cushioned in the packagings.	25 kg	230 kg	No

ADDITIONAL PACKING REQUIREMENTS FOR COMBINATION PACKAGINGS

- Packagings must meet the Packing Group II performance requirements.

OUTER PACKAGINGS OF COMBINATION PACKAGINGS (see 6;3.1)

Boxes

Aluminium (4B)
Fibreboard (4G)
Natural wood (4C1, 4C2)
Plastics (4H2)
Plywood (4D)
Reconstituted wood (4F)
Steel (4A)

Packing Instruction 872

Passenger and cargo aircraft for UN 2800

General requirements

Part 4, Chapter 1 requirements must be met, including:

1) Compatibility requirements

- Substances must be compatible with their packagings as required by 4;1.1.3.
- Metal packagings must be corrosion resistant or be protected against corrosion.

2) Closure requirements

- Closures must meet the requirements of 4;1.1.4.

COMBINATION PACKAGINGS				SINGLE PACKAGINGS
<i>UN number and proper shipping name</i>	<i>Packing conditions</i>	<i>Total quantity per package — passenger</i>	<i>Total quantity per package — cargo</i>	
UN 2800 Batteries, wet, non- spillable	Batteries must be protected against short circuits and must be securely packed in strong outer packagings.	No limit	No limit	No

OUTER PACKAGINGS OF COMBINATION PACKAGINGS (see 6;3.1)

Boxes

Drums

Jerricans

Strong outer packagings

TESTING

Batteries can be considered as non-spillable provided that they are capable of withstanding the vibration and pressure differential tests given below, without leakage of battery fluid.

Vibration test: The battery is rigidly clamped to the platform of a vibration machine and a simple harmonic motion having an amplitude of 0.8 mm (1.6 mm maximum total excursion) is applied. The frequency is varied at the rate of 1 Hz/min between the limits of 10 Hz to 55 Hz. The entire range of frequencies and return is traversed in 95 ± 5 minutes for each mounting position (direction of vibration) of the battery. The battery must be tested in three mutually perpendicular positions (to include testing with fill openings and vents, if any, in an inverted position) for equal time periods.

Pressure differential test: Following the vibration test, the battery is stored for six hours at $24^{\circ}\text{C} \pm 4^{\circ}\text{C}$ while subjected to a pressure differential of at least 88 kPa. The battery must be tested in three mutually perpendicular positions (to include testing with fill openings and vents, if any, in an inverted position) for at least six hours in each position.

Note.— Non-spillable type batteries which are an integral part of, and necessary for the operation of, mechanical or electronic equipment must be securely fastened in the battery holder on the equipment and protected in such a manner so as to prevent damage and short circuits.

Packing Instruction 873

Passenger and cargo aircraft for UN 3477

General requirements

Part 4;1.1.1, 1.1.2 and 1.1.8 requirements must be met, including:

1) Compatibility requirements

- Substances must be compatible with their packagings as required by 4;1.1.3.

<i>UN number and proper shipping name</i>	<i>Quantity — passenger</i>	<i>Quantity — cargo</i>
UN 3477 Fuel cell cartridges	5 kg of fuel cell cartridges	50 kg of fuel cell cartridges

ADDITIONAL PACKING REQUIREMENTS

- Fuel cell cartridges must be securely cushioned in the outer packagings.
- The mass of each fuel cell cartridge must not exceed 1 kg.
- Packagings must meet the Packing Group II performance requirements.

OUTER PACKAGINGS OF COMBINATION PACKAGINGS (see 6;3.1)

Boxes

Aluminium(4B)
Fibreboard (4G)
Natural wood (4C1, 4C2)
Other metal (4N)
Plastics (4H2)
Plywood (4D)
Reconstituted wood (4F)
Steel (4A)

Drums

Aluminium(1B2)
Fibre (1G)
Other metal (1N2)
Plastics (1H2)
Plywood (1D)
Steel (1A2)

Jerricans

Aluminium (3B2)
Plastics (3H2)
Steel (3A2)

Packing Instruction Y873

Limited quantities for UN 3477 only

General requirements

Part 3;4 requirements must be met.

Single packagings are not permitted for limited quantities.

For the purpose of this packing instruction, a fuel cell cartridge is considered an inner packaging.

1) Compatibility requirements

- Substances must be compatible with their packagings as required by 4;1.1.3.

<i>UN number and name</i>	<i>Maximum quantity per package</i>
UN 3477 Fuel cell cartridges, containing corrosive substances	2.5 kg of fuel cell cartridges

ADDITIONAL PACKING REQUIREMENTS

- Fuel cell cartridges must be securely cushioned in the outer packagings.
- Fuel cell cartridges must not exceed 0.2 L of liquid corrosive fuel or 0.2 kg of solid corrosive fuel per cartridge.

OUTER PACKAGINGS OF COMBINATION PACKAGINGS (see 6;3.1)

Boxes

Aluminium
 Fibreboard
 Natural wood
 Other metal
 Plastics
 Plywood
 Reconstituted wood
 Steel

Drums

Aluminium
 Fibre
 Other metal
 Plastics
 Plywood
 Steel

Jerricans

Aluminium
 Plastics
 Steel

Packing Instruction 874

Passenger and cargo aircraft for UN 3477 (contained in equipment) only

General requirements

Part 4;1.1.1 and 1.1.8 requirements must be met, including:

1) Compatibility requirements

- Substances must be compatible with their packagings as required by 4;1.1.3.

<i>UN number and name</i>	<i>Quantity — passenger</i>	<i>Quantity — cargo</i>
UN 3477 Fuel cell cartridges contained in equipment , containing corrosive substances	5 kg of fuel cell cartridges	50 kg of fuel cell cartridges

ADDITIONAL PACKING REQUIREMENTS

- Fuel cell cartridges that are contained in equipment must be protected against short circuit and the equipment must be protected against inadvertent operation.
- Equipment must be securely cushioned in the outer packagings.
- The mass of each fuel cell cartridge must not exceed 1 kg.
- Fuel cell systems must not charge batteries during transport.
- On passenger aircraft, each fuel cell system and each fuel cell cartridge must conform to IEC 62282-6-100 Ed. 1, including Amendment 1, or a standard approved by the appropriate authority of the State of Origin.

OUTER PACKAGINGS OF COMBINATION PACKAGINGS (see 6;3.1)

Boxes

Drums

Jerricans

Strong outer packagings

Packing Instruction 875

Passenger and cargo aircraft for UN 3477 (packed with equipment) only

General requirements

Part 4;1.1.1 and 1.1.8 requirements must be met, including:

1) Compatibility requirements

- Substances must be compatible with their packagings as required by 4;1.1.3.

<i>UN number and name</i>	<i>Quantity — passenger</i>	<i>Quantity — cargo</i>
UN 3477 Fuel cell cartridges packed with equipment , containing corrosive substances	5 kg of fuel cell cartridges	50 kg of fuel cell cartridges

ADDITIONAL PACKING REQUIREMENTS

- When fuel cell cartridges are packed with equipment, they must be packed in intermediate packagings together with the equipment they are capable of powering.
- The maximum number of fuel cell cartridges in the intermediate packaging must be the minimum number required to power the equipment, plus 2 spares.
- The fuel cell cartridges and the equipment must be packed with cushioning material or divider(s) or inner packaging so that the fuel cell cartridges are protected against damage that may be caused by the movement or placement of the equipment and the cartridges within the packaging.
- The mass of each fuel cell cartridge must not exceed 1 kg.

OUTER PACKAGINGS OF COMBINATION PACKAGINGS (see 6;3.1)

Boxes

Drums

Jerricans

Strong outer packagings

Packing Instruction 876

Cargo aircraft only for Chlorosilanes

General requirements

Part 4, Chapter 1 requirements must be met, including:

1) Compatibility requirements

- Substances must be compatible with their packagings as required by 4;1.1.3.
- Metal packagings must be corrosion resistant or be protected against corrosion.

2) Closure requirements

- Closures must meet the requirements of 4;1.1.4.

COMBINATION PACKAGINGS				SINGLE PACKAGINGS	
UN number	Inner packaging (see 6;3.2)	Net quantity per inner packaging — cargo	Total quantity per package — cargo	Passenger	Cargo
UN 1724, UN 1728, UN 1747, UN 1753, UN 1762, UN 1763, UN 1766, UN 1767, UN 1769, UN 1771, UN 1781, UN 1784, UN 1799, UN 1800, UN 1801, UN 1804, UN 1816, UN 1818, UN 2434, UN 2435, UN 2437, UN 2986, UN 2987	Glass	1.0 L	30.0 L	No	30.0 L
	Plastics	Forbidden			
	Steel	5.0 L			

OUTER PACKAGINGS OF COMBINATION PACKAGINGS

Boxes

Fibreboard (4G)
Natural wood (4C1, 4C2)
Plastics (4H1, 4H2)
Plywood (4D)
Reconstituted wood (4F)
Steel (4A)

Drums

Fibre (1G)
Plastics (1H1, 1H2)
Plywood (1D)
Steel (1A1, 1A2)

SINGLE PACKAGINGS FOR CARGO AIRCRAFT ONLY

Composites

Plastic receptacle in steel drum (6HA1)

Cylinders

Steel (as permitted by 4;2.7)

Drums

Steel (1A1)

Jerricans

Steel (3A1)

+

Packing Instruction 877

Passenger and cargo aircraft for UN 3507 only

General requirements

Part 4, Chapter 1 and Part 4;9.1.2, 9.1.4 and 9.1.7 requirements must be met, including:

1) Compatibility requirements

- Substances must be compatible with their packagings as required by 4;1.1.3.
- Metal packagings must be corrosion resistant or be protected against corrosion.

2) Closure requirements

- Closures must meet the requirements of 4;1.1.4.

<i>UN number and name</i>	<i>Quantity per package — passenger</i>	<i>Quantity per package — cargo</i>
UN 3507 Uranium hexafluoride, radioactive material, excepted package, non-fissile or fissile-excepted	Less than 0.1 kg	Less than 0.1 kg

ADDITIONAL PACKING REQUIREMENTS FOR COMBINATION PACKAGINGS

- Substances must be packed in a metal or plastics primary receptacle in a leakproof rigid secondary packaging in a rigid outer packaging.
- Primary inner receptacles must be packed in secondary packagings in a way that, under normal conditions of transport, they cannot break, be punctured or leak their contents into the secondary packaging. Secondary packagings must be secured in outer packagings with suitable cushioning material to prevent movement. If multiple primary receptacles are placed in a single secondary packaging, they must be either individually wrapped or separated so as to prevent contact between them.
- The contents must comply with the provisions of 2;7.2.4.5.2.
- The provisions of 6;7.3 must be met.
- In the case of fissile-excepted material, limits specified in 2;7.2.3.5 and 6;7.10.2.

OUTER PACKAGINGS OF COMBINATION PACKAGINGS (see 6;3.1)

Boxes

Aluminium (4B)
Fibreboard (4G)
Natural wood (4C1, 4C2)
Plastics (4H1, 4H2)
Plywood (4D)
Reconstituted wood (4F)
Steel (4A)

Drums

Aluminium (1B2)
Fibre (1G)
Other metal (1N2)
Plastics (1H2)
Plywood (1D)
Steel (1A2)

Jerricans

Aluminium (3B2)
Plastics (3H2)
Steel (3A2)

Chapter 11

CLASS 9 — MISCELLANEOUS DANGEROUS GOODS

Parts of this Chapter are affected by State Variation US 2; see Table A-1

Packing Instruction 950

Passenger and cargo aircraft for UN 3166 only
(See Packing Instruction 951 for flammable gas-powered vehicles and engines or
Packing Instruction 952 for battery-powered equipment and vehicles)

General requirements

Part 4, Chapter 1 requirements must be met, including:

Compatibility requirements

- Substances must be compatible with their packagings as required by 4;1.1.3.

<i>UN number and proper shipping name</i>	<i>Quantity — passenger</i>	<i>Quantity — cargo</i>
UN 3166 Engines, internal combustion, flammable liquid powered or Vehicle, flammable liquid powered or Vehicle, fuel cell, flammable liquid powered or Engine, fuel cell, flammable powered	No limit	No limit

ADDITIONAL PACKING REQUIREMENTS

Flammable liquid fuel tanks

Except as otherwise provided for in this packing instruction, fuel tanks must be drained of fuel and tank caps fitted securely. Special precautions are necessary to ensure complete drainage of the fuel system of vehicles, machines or equipment incorporating internal combustion engines, such as lawn mowers and outboard motors, where such machines or equipment could possibly be handled in other than an upright position. When it is not possible to handle in other than an upright position, vehicles, except those with diesel engines, must be drained of fuel as far as practicable, and if any fuel remains, it must not exceed one-quarter of the tank capacity.

Diesel engines

Vehicles equipped with diesel engines are excepted from the requirement to drain the fuel tanks, provided that a sufficient ullage space has been left inside the tank to allow fuel expansion without leakage, and the tank caps are tightly closed. A careful check must be made to ensure there are no fuel leakages.

Batteries

All batteries must be installed and securely fastened in the battery holder of the vehicle, machine or equipment and must be protected in such a manner so as to prevent damage and short circuits. In addition:

- 1) if spillable batteries are installed, and it is possible for the vehicle, machine or equipment to be handled in such a way that batteries would not remain in their intended orientation, they must be removed and packed according to Packing Instruction 492 or 870 as applicable;
- 2) if lithium batteries are installed, they must meet the provisions of Part 2;9.3, unless otherwise approved by the appropriate authority of the State of Origin, must be securely fastened in the vehicle, machine or equipment and must be protected in such a manner so as to prevent damage and short circuits; and
- 3) if sodium batteries are installed they must conform to the requirements of Special Provision A94.

Other operational equipment

- 1) Dangerous goods required for the operation or safety of the vehicle, machine or equipment, such as fire extinguishers, tire inflation canisters or safety devices, must be securely mounted in the vehicle, machine or equipment. Aircraft may also contain other articles and substances which would otherwise be classified as dangerous goods but which are installed in that aircraft in accordance with the pertinent airworthiness requirements and operating regulations. If fitted, life-rafts, emergency escape slides and other inflation devices must be protected such that they cannot be activated accidentally. Vehicles containing dangerous goods identified in Table 3-1 as forbidden on passenger aircraft may only be transported on cargo aircraft. Replacements for the dangerous goods permitted must not be carried under this packing instruction.
- 2) Vehicles equipped with theft-protection devices, installed radio communications equipment or navigational systems must have such devices, equipment or systems disabled.

Internal combustion or fuel cell engine shipped separately (not installed)

- 1) When internal combustion engines or fuel cell engines are being shipped separately, all fuel, coolant or hydraulic systems remaining in or on the engine must be drained as far as practicable and all disconnected fluid pipes must be sealed with leakproof caps, which are positively retained.
- 2) This requirement also applies to vehicles, machines or equipment containing internal combustion engines or fuel cell engines which are being shipped in a dismantled state such that fuel lines have been disconnected.

Packing Instruction 951

Cargo aircraft only for UN 3166 only
 (See Packing Instruction 950 for flammable liquid-powered vehicles and engines or
 Packing Instruction 952 for battery-powered equipment and vehicles)

General requirements

Part 4, Chapter 1 requirements must be met, including:

Compatibility requirements

- Substances must be compatible with their packagings as required by 4;1.1.3.

<i>UN number and proper shipping name</i>	<i>Quantity — passenger</i>	<i>Quantity — cargo</i>
UN 3166 Engines, internal combustion, flammable gas powered or Vehicle, flammable gas powered or Vehicle, fuel cell, flammable gas powered, or Engine, fuel cell, flammable gas powered	Forbidden	No limit

ADDITIONAL PACKING REQUIREMENTS*Flammable gas vessels*

- 1) for flammable gas-powered vehicles, machines or equipment, pressurized vessels containing the flammable gas must be completely emptied of flammable gas. Lines from vessels to gas regulators, and gas regulators themselves, must also be drained of all trace of flammable gas. To ensure that these conditions are met, gas shut-off valves must be left open and connections of lines to gas regulators must be left disconnected upon delivery of the vehicle to the operator. Shut-off valves must be closed and lines reconnected at gas regulators before loading the vehicle aboard the aircraft;
- or alternatively,
- 2) flammable gas-powered vehicles, machines or equipment that have pressure receptacles (fuel tanks) equipped with electrically operated valves that close automatically in case the power is disconnected, or with manual shut-off valves, may be transported under the following conditions:
 - i) the tank shut-off valves must be in the closed position and in the case of electrically operated valves, power to those valves must be disconnected;

- ii) after closing the tank shut-off valves, the vehicle, equipment or machinery must be operated until it stops from lack of fuel before being loaded aboard the aircraft;
- iii) in no part of the closed system must the remaining pressure of compressed gases exceed 5 per cent of the maximum allowable working pressure of the pressure receptacle (fuel tank) system, or more than 2 000 kPa (20 bar), whichever is the lower.

Batteries

All batteries must be installed and securely fastened in the battery holder of the vehicle, machine or equipment and must be protected in such a manner so as to prevent damage and short circuits. In addition:

- 1) if spillable batteries are installed, and it is possible for the vehicle, machine or equipment to be handled in such a way that batteries would not remain in their intended orientation, they must be removed and packed according to Packing Instruction 492 or 870 as applicable;
- 2) if lithium batteries are installed, they must meet the provisions of Part 2;9.3, unless otherwise approved by the appropriate authority of the State of Origin, must be securely fastened in the vehicle, machinery or equipment and must be protected in such a manner so as to prevent damage and short circuits; and
- 3) if sodium batteries are installed they must conform to the requirements of Special Provision A94.

Other operational equipment

- 1) Dangerous goods required for the operation or safety of the vehicle, machine or equipment, such as fire extinguishers, tire inflation canisters or safety devices, must be securely mounted in the vehicle, machine or equipment. Aircraft may also contain other articles and substances which would otherwise be classified as dangerous goods but which are installed in that aircraft in accordance with the pertinent airworthiness requirements and operating regulations. If fitted, life-rafts, emergency escape slides and other inflation devices must be protected such that they cannot be activated accidentally. Vehicles containing dangerous goods identified in Table 3-1 as forbidden on passenger aircraft may only be transported on cargo aircraft. Replacements for the dangerous goods permitted must not be carried under this packing instruction.
- 2) Vehicles equipped with theft-protection devices, installed radio communications equipment or navigational systems must have such devices, equipment or systems disabled.

Internal combustion or fuel cell engine shipped separately (not installed)

- 1) When internal combustion engines or fuel cell engines are being shipped separately, all fuel, coolant or hydraulic systems remaining in or on the engine must be drained as far as practicable and all disconnected fluid pipes must be sealed with leakproof caps, which are positively retained.
- 2) This requirement also applies to vehicles, machines or equipment containing internal combustion engines or fuel cell engines which are being shipped in a dismantled state such that fuel lines have been disconnected.

Packing Instruction 952

Passenger and cargo aircraft for UN 3171 only
(See Packing Instruction 950 for flammable liquid-powered vehicles and engines or
Packing Instruction 951 for flammable gas-powered vehicles and engines)

General requirements

Part 4, Chapter 1 requirements must be met, including:

1) Compatibility requirements

- Substances must be compatible with their packagings as required by 4;1.1.3.

2) Closure requirements

- Closures must meet the requirements of 4;1.1.4.

<i>UN number and proper shipping name</i>	<i>Quantity — passenger</i>	<i>Quantity — cargo</i>
UN 3171 Battery-powered equipment or Battery-powered vehicle	No limit	No limit

ADDITIONAL PACKING REQUIREMENTS

This entry applies to vehicles and equipment which are powered by wet batteries, sodium batteries or lithium batteries and which are transported with these batteries installed. Examples of such vehicles and equipment are electrically-powered cars, lawn mowers, wheelchairs and other mobility aids. Vehicles that also contain an internal combustion engine must be consigned under the entry UN 3166 Vehicle (flammable gas powered) (See Packing Instruction 951) or Vehicle (flammable liquid powered) (See Packing Instruction 950), as appropriate.

Battery-powered vehicles, machines or equipment must meet the following requirements:

Batteries

All batteries must be installed and securely fastened in the battery holder of the vehicle, machine or equipment and must be protected in such a manner so as to prevent damage and short circuits. In addition:

- 1) if spillable batteries are installed, and it is possible for the vehicle, machine or equipment to be handled in such a way that batteries would not remain in their intended orientation, they must be removed and packed according to Packing Instruction 492 or 870 as applicable;
- 2) if lithium batteries are installed in a vehicle, they must meet the provisions of Part 2;9.3, unless otherwise approved by the appropriate authority of the State of Origin, must be securely fastened in the vehicle and must be protected in such a manner so as to prevent damage and short circuits; and
- 3) if sodium batteries are installed they must conform to the requirements of Special Provision A94.

Other operational equipment

- 1) Dangerous goods required for the operation or safety of the vehicle, machine or equipment, such as fire extinguishers, tire inflation canisters or safety devices, must be securely mounted in the vehicle, machine or equipment. Aircraft may also contain other articles and substances which would otherwise be classified as dangerous goods but which are installed in that aircraft in accordance with the pertinent airworthiness requirements and operating regulations. If fitted, life-rafts, emergency escape slides and other inflation devices must be protected such that they cannot be activated accidentally. Vehicles containing dangerous goods identified in Table 3-1 as forbidden on passenger aircraft may only be transported on cargo aircraft. Replacements for the dangerous goods permitted must not be carried under this packing instruction.
- 2) Vehicles equipped with theft-protection devices, installed radio communications equipment or navigational systems must have such devices, equipment or systems disabled.

Packing Instruction 953

Passenger and cargo aircraft for UN 2807 only

<i>UN number and proper shipping name</i>	<i>Quantity — passenger</i>	<i>Quantity — cargo</i>
UN 2807 Magnetized material	No limit	No limit

Magnetized materials with field strengths causing a compass deflection of more than 2 degrees at a distance of 2.1 m but not more than 2 degrees at a distance of 4.6 m (equivalent to 0.418 A/m or 0.00525 Gauss measured at a distance of 4.6 m) are not subject to any other requirements in these Instructions when carried as cargo except for the following:

- a) the shipper must make prior arrangements with the operator identifying the magnetized material. The dangerous goods transport document requirements of Part 5;4 are not applicable provided alternative written or electronic documentation includes the words "magnetized material" in association with the description of the goods;
- b) the package must bear the magnetized material handling label;
- c) the operator must stow the packaged magnetized material in accordance with 7;2.10; and
- d) the incident reporting requirements of 7;4.4 must be met.

Magnetized material with a field strength sufficient to cause a compass deflection of more than 2 degrees at a distance of 4.6 m may only be transported with the prior approval of the appropriate authority of the State of Origin and the State of the Operator.

Packing Instruction 954

Passenger and cargo aircraft for UN 1845 only

General requirements

Part 4, Chapter 1 requirements must be met, including:

1) Compatibility requirements

- Substances must be compatible with their packagings as required by 4;1.1.3.

2) Closure requirements

- Closures must meet the requirements of 4;1.1.4.

<i>UN number and proper shipping name</i>	<i>Quantity — passenger</i>	<i>Quantity — cargo</i>
UN 1845 Carbon dioxide, solid or Dry ice	200 kg	200 kg

ADDITIONAL PACKING REQUIREMENTS

In packages:

- a) must be packed in accordance with the general packing requirements of 4;1 and be in packaging designed and constructed to permit the release of carbon dioxide gas to prevent a build-up of pressure that could rupture the packaging;
- b) the shipper must make arrangements with the operator(s) for each shipment, to ensure that ventilation safety procedures are followed;

- c) the dangerous goods transport document requirements of 5;4 are not applicable provided alternative written documentation is provided describing the contents. The information on the document must be shown in the location provided for the description of the goods. Where an agreement exists with the operator, the shipper may provide the information by electronic data processing (EDP) or electronic data interchange (EDI) techniques. The information required is as follows and should be shown in the following order:
- 1) UN 1845;
 - 2) **Carbon dioxide, solid** or **Dry ice**;
 - 3) the number of packages and the net quantity of dry ice in each package; and
 - d) the net mass of the **Carbon dioxide, solid** or **Dry ice** must be marked on the outside of the package.

Dry ice used for other than dangerous goods may be shipped in a unit load device or other type of pallet prepared by a single shipper provided that:

- a) the shipper has made prior arrangements with the operator;
- b) the unit load device, or other type of pallet, must allow the venting of the carbon dioxide gas to prevent a dangerous build-up of pressure (the marking requirements of 5;2 and the labelling requirements of 5;3 do not apply to the unit load device); and
- c) the shipper must provide the operator with written documentation or, where agreed with the operator, information by EDP or EDI techniques, stating the total quantity of the dry ice contained in the unit load device or other type of pallet.

Packing Instruction 955

Passenger and cargo aircraft for UN 2990 and UN 3072 only

- + The term "life-saving appliances" applies to articles such as life rafts, life vests, aircraft survival kits or aircraft evacuation slides.
- + The description "Life-saving appliances, self-inflating" (UN 2990) is intended to apply to life-saving appliances that present a hazard if the self-inflating device is activated accidentally.

General requirements

Part 4, Chapter 1 requirements must be met, including:

1) Compatibility requirements

- Substances must be compatible with their packagings as required by 4;1.1.3.

2) Closure requirements

- Closures must meet the requirements of 4;1.1.4.

<i>UN number and proper shipping name</i>	<i>Quantity — passenger</i>	<i>Quantity — cargo</i>
UN 2990 Life-saving appliances, self-inflating UN 3072 Life-saving appliances, not self-inflating containing dangerous goods as equipment	No limit	No limit

ADDITIONAL PACKING REQUIREMENTS

Life-saving appliances may only contain the dangerous goods listed below:

- a) Division 2.2 gases, must be contained in cylinders which conform to the requirements of the appropriate national authority of the country in which they are approved and filled. Such cylinders may be connected to the life-saving appliance. These cylinders may include installed actuating cartridges (cartridges, power device of Division 1.4C and 1.4S) provided the aggregate quantity of deflagrating (propellant) explosives does not exceed 3.2 grams per unit. When the cylinders are shipped separately, they must be classified as appropriate for the Division 2.2 gas contained and need not be marked, labelled or described as explosive articles;

- b) signal devices (Class 1), which may include smoke and illumination signal flares; signal devices must be packed in plastic or fibreboard inner packagings;
- c) small quantities of flammable substances, corrosive solids and organic peroxides (Class 3, Class 8, Division 4.1 and 5.2), which may include a repair kit and not more than 30 strike-anywhere matches. The organic peroxide may only be a component of a repair kit and the kit must be packed in strong inner packaging. The strike-anywhere matches must be packed in a cylindrical metal or composition packaging with a screw-type closure and be cushioned to prevent movement;
- ≠ d) electric storage batteries (Class 8), which must be disconnected or electrically isolated and protected against short circuits;
- + e) lithium batteries:
 - 1) must meet the applicable requirements of 2;9.3;
 - 2) must be disconnected or electrically isolated and protected against short circuits; and
 - 3) must be secured against movement within the appliance.
- ≠ f) first aid kits which may include flammable, corrosive and toxic articles or substances.

The appliances must be packed, so that they cannot be accidentally activated, in strong outer packagings and, except for life vests, the dangerous goods must be in inner packagings packed so as to prevent movement. The dangerous goods must be an integral part of the appliance without which it would not be operational and in quantities which do not exceed those appropriate for the actual appliance when in use.

Life-saving appliances packed in strong rigid outer packagings with a total maximum gross mass of 40 kg, containing no dangerous goods other than Division 2.2 compressed or liquefied gases with no subsidiary risk in receptacles with a capacity not exceeding 120 mL, installed solely for the purpose of the activation of the appliance, are not subject to these Instructions when carried as cargo.

Life-saving appliances may also include articles and substances not subject to these Instructions which are an integral part of the appliance.

Packing Instruction 956

Passenger and cargo aircraft for UN 1841, UN 1931, UN 3432, UN 2969, UN 3077, UN 3152 and UN 3335 only

General requirements

Part 4, Chapter 1 requirements must be met, including:

1) Compatibility requirements

- Substances must be compatible with their packagings as required by 4;1.1.3.

2) Closure requirements

- Closures must meet the requirements of 4;1.1.4.

COMBINATION PACKAGINGS					SINGLE PACKAGINGS	
<i>UN number and proper shipping name</i>	<i>Inner packaging (see 6;3.2)</i>	<i>Inner packaging quantity (per receptacle)</i>	<i>Total quantity per package — passenger</i>	<i>Total quantity per package — cargo</i>	<i>Quantity — passenger</i>	<i>Quantity — cargo</i>
UN 1841 Acetaldehyde ammonia	Glass	10.0 kg	200 kg	200 kg	200 kg	200 kg
	Fibre	50.0 kg				
	Metal	50.0 kg				
	Paper bag	50.0 kg				
	Plastics	50.0 kg				
	Plastic bag	50.0 kg				
UN 1931 Zinc dithionite or Zinc hydrosulphite	Glass	10.0 kg	100 kg	200 kg	100 kg	200 kg
	Fibre	50.0 kg				
	Metal	50.0 kg				
	Paper bag	50.0 kg				
	Plastics	50.0 kg				
	Plastic bag	50.0 kg				
UN 2969 Castor beans or Castor flake or Castor meal or Castor pomace	Glass	10.0 kg	No limit	No limit	No Limit	No Limit
	Fibre	50.0 kg				
	Metal	50.0 kg				
	Paper bag	50.0 kg				
	Plastics	50.0 kg				
	Plastic bag	50.0 kg				
UN 3077 Environmentally hazardous substance, solid, n.o.s.	Glass	10.0 kg	400 kg	400 kg	400 kg	400 kg
	Fibre	50.0 kg				
	Metal	50.0 kg				
	Paper bag	50.0 kg				
	Plastics	50.0 kg				
	Plastic bag	50.0 kg				
UN 3152 Polyhalogenated biphenyls, solid or Polyhalogenated terphenyls, solid	Glass	10.0 kg	100 kg	200 kg	100 kg	200 kg
	Fibre	50.0 kg				
	Metal	50.0 kg				
	Paper bag	50.0 kg				
	Plastics	50.0 kg				
	Plastic bag	50.0 kg				
UN 3335 Aviation regulated solid, n.o.s.	Glass	10.0 kg	400 kg	400 kg	400 kg	400 kg
	Fibre	50.0 kg				
	Metal	50.0 kg				
	Paper bag	50.0 kg				
	Plastics	50.0 kg				
	Plastic bag	50.0 kg				
UN 3432 Polychlorinated biphenyls, solid	Glass	10.0 kg	100 kg	200 kg	100 kg	200 kg
	Fibre	50.0 kg				
	Metal	50.0 kg				
	Paper bag	50.0 kg				
	Plastics	50.0 kg				
	Plastic bag	50.0 kg				

OUTER PACKAGINGS OF COMBINATION PACKAGINGS (see 6;3.1)
Boxes

Aluminium (4B)
 Fibreboard (4G)
 Natural wood (4C1, 4C2)
 Other metal (4N)
 Plastics (4H1, 4H2)
 Plywood (4D)
 Reconstituted wood (4F)
 Steel (4A)

Drums

Aluminium (1B1, 1B2)
 Fibre (1G)
 Other metal (1N1, 1N2)
 Plastics (1H1, 1H2)
 Steel (1A1, 1A2)

Jerricans

Aluminium (3B1, 3B2)
 Plastics (3H1, 3H2)
 Steel (3A1, 3A2)

ADDITIONAL PACKING REQUIREMENTS FOR SINGLE PACKAGINGS

— Fibre, fibreboard, wood and plywood single packagings must be fitted with a suitable liner.

SINGLE PACKAGINGS

<i>Bags</i>	<i>Boxes</i>	<i>Composites</i>	<i>Cylinders</i>	<i>Drums</i>	<i>Jerricans</i>
Paper (5M2) Plastic film (5H4) Textile (5L3) Woven plastics (5H3)	Aluminium (4B) Fibreboard (4G) Natural wood (4C2) Other metal (4N) Plastics (4H2) Plywood (4D) Reconstituted wood (4F) Steel (4A)	All (see 6;3.1.18)	See 4;2.7	Aluminium (1B1, 1B2) Fibre (1G) Other metal (1N1, 1N2) Plastics (1H1, 1H2) Plywood (1D) Steel (1A1, 1A2)	Aluminium (3B1, 3B2) Plastics (3H1, 3H2) Steel (3A1, 3A2)

INTERMEDIATE BULK CONTAINERS FOR UN 3077 ONLY

For UN 3077, irrespective of the maximum net quantities specified in the columns 11 and 13 of the Dangerous Goods List (Table 3-1) and as provided above for single packagings, intermediate bulk containers (IBCs) with a maximum net quantity not exceeding 1 000 kg are permitted as shown below. Each IBC must be in accordance with Chapter 6.5 of the United Nations Model Regulations and must bear the required UN mark.

<i>Metal</i>	<i>Rigid plastic</i>	<i>Composite with plastic inner receptacle</i>	<i>Fibreboard</i>	<i>Wooden</i>	<i>Flexible</i>
Steel (11A), (21A) Aluminium (11B), (21B) Other than steel or aluminium (11N), (21N)	For solids, filled or discharged by gravity, fitted with structural equipment (11H1) For solids, filled or discharged by gravity, free-standing (11H2) For solids, filled or discharged under pressure, fitted with structural equipment (21H1) For solids, filled or discharged under pressure, free-standing (21H2)	For solids, filled or discharged by gravity, with rigid plastic inner receptacle (11HZ1) For solids, filled or discharged by gravity, with flexible plastic inner receptacle (11HZ2) For solids, filled or discharged under pressure, with rigid plastic inner receptacle (21HZ1) For solids, filled or discharged under pressure, with flexible plastic inner receptacle (21HZ2) (The IBC Code must be completed by replacing the letter Z with a capital letter indicating the nature of the material used for the outer casing (A for steel; B for aluminium; C for natural wood;	For solids, filled or discharged by gravity (11G)	Natural wood for solids, filled or discharged by gravity with inner liner (11C) Plywood for solids, filled or discharged by gravity, with inner liner (11D) Reconstituted wood for solids, filled or discharged by gravity, with inner liner (11F)	Woven plastic, coated (13H2) Woven plastic with liner (13H3) Woven plastic, coated and with liner (13H4) Plastic film (13H5) Textile coated (13L2) Textile with liner (13L3) Textile coated and with liner (13L4) Paper multi-wall (13M1) Paper multi-wall, water-resistant (13M2)

D for plywood; F for reconstituted wood; G for fibreboard; H for plastic material; L for textile; M for paper, multi-walled; and N for metal other than steel or aluminium.)

ADDITIONAL PACKING REQUIREMENTS FOR INTERMEDIATE BULK CONTAINERS

- Flexible IBCs must be sift-proof and water-resistant or must be fitted with a sift-proof and water-resistant liner.

Packing Instruction Y956

Limited quantities
 Passenger and cargo aircraft for UN 3077 and UN 3335 only

General requirements

Part 4, Chapter 1 requirements must be met (except that 4;1.1.2, 1.1.9 c), 1.1.9 e), 1.1.16, 1.1.18 and 1.1.20 do not apply), including:

1) **Compatibility requirements**

- Substances must be compatible with their packagings as required by 4;1.1.3.

2) **Closure requirements**

- Closures must meet the requirements of 4;1.1.4.

3) **Limited quantity requirements**

- Part 3, Chapter 4 requirements must be met, including:
 - the capability of the package to pass a 1.2 m drop test; and
 - a 24-hour stacking test.

COMBINATION PACKAGINGS						SINGLE PACKAGINGS
UN number and proper shipping name	Packing group	Inner packaging (see 6;3.2)	Inner packaging quantity (per receptacle)	Total quantity per package	Total gross mass per package	
UN 3077 Environmentally hazardous substance, solid, n.o.s. UN 3335 Aviation regulated solid, n.o.s.*	III	Glass	5.0 kg	30 kg	30 kg	No
		Plastics	5.0 kg			
		Metal	5.0 kg			
		Paper bag	5.0 kg			
		Plastic bag	5.0 kg			
		Fibre	5.0 kg			

OUTER PACKAGINGS OF COMBINATION PACKAGINGS (see 6;3.1)*Boxes*

Aluminium
Fibreboard
Natural wood
Other metal
Plastics
Plywood
Reconstituted wood
Steel

Drums

Aluminium
Fibre
Other metal
Plastics
Steel

Jerricans

Aluminium
Plastics
Steel

Packing Instruction 957

Passenger and cargo aircraft for UN 2211 and UN 3314 only

General requirements

Part 4, Chapter 1 requirements must be met, including:

1) Compatibility requirements

— Substances must be compatible with their packagings as required by 4;1.1.3.

2) Closure requirements

— Closures must meet the requirements of 4;1.1.4.

<i>UN number and proper shipping name</i>	<i>Quantity — passenger</i>	<i>Quantity — cargo</i>	SINGLE PACKAGINGS
UN 2211 Polymeric beads, expandable , evolving flammable vapour			
UN 3314 Plastics moulding compound in dough, sheet or extruded rope form evolving flammable vapour	100 kg	200 kg	Yes

ADDITIONAL PACKING REQUIREMENTS

For other than metal packagings, a sealed plastic liner must be used.

SINGLE PACKAGINGS*Boxes*

Fibreboard (4G)
Other metal (4N)
Plywood (4D)
Reconstituted wood (4F)
Wooden (4C1, 4C2)

Drums

Aluminium (1B1, 1B2)
Fibre (1G)
Plywood (1D)
Steel (1A1, 1A2)

Packing Instruction 958

Passenger and cargo aircraft for UN 2071 and UN 2590 only

General requirements

Part 4, Chapter 1 requirements must be met, including:

1) **Compatibility requirements**

- Substances must be compatible with their packagings as required by 4;1.1.3.

2) **Closure requirements**

- Closures must meet the requirements of 4;1.1.4.

<i>UN number and proper shipping name</i>	<i>Quantity — passenger</i>	<i>Quantity — cargo</i>	SINGLE PACKAGINGS
UN 2071 Ammonium nitrate fertilizers UN 2590 Asbestos, chrysotile	200 kg	200 kg	Yes

ADDITIONAL PACKING REQUIREMENTS

For UN 2071 and 2590

- All rigid packagings must be sift-proof.

For UN 2590

- Bags must be palletized and unitized by methods such as shrink wrapping in plastic film or wrapping in fibreboard secured by strapping.

SINGLE PACKAGINGS

Bags

Plastics (5H4)
Textile(5L3)
Woven plastics (5H3)

Boxes

Fibreboard (4G)
Natural wood (4C2)
Other metal (4N)
Plastics (4H1, 4H2)
Plywood (4D)
Reconstituted wood (4F)

Drums

Aluminium (1B2)
Fibre (1G)
Plastics (1H2)
Plywood (1D)
Steel (1A2)

Jerricans

Plastics (3H2)
Steel (3A2)

Packing Instruction Y958

Limited quantities
Passenger and cargo aircraft

General requirements

Part 4, Chapter 1 requirements must be met (except that 4;1.1.2, 1.1.9 c), 1.1.9 e), 1.1.16, 1.1.18 and 1.1.20 do not apply), including:

1) Compatibility requirements

- Substances must be compatible with their packagings as required by 4;1.1.3.

2) Closure requirements

- Closures must meet the requirements of 4;1.1.4.

3) Limited quantity requirements

- Part 3, Chapter 4 requirements must be met, including:
 - the capability of the package to pass a 1.2 m drop test; and
 - a 24-hour stacking test.

COMBINATION PACKAGINGS						SINGLE PACKAGINGS
<i>UN number and proper shipping name</i>	<i>Packing group</i>	<i>Inner packaging (see 6;3.2)</i>	<i>Inner packaging quantity (per receptacle)</i>	<i>Total quantity per package</i>	<i>Total gross mass per package</i>	
UN 2071 Ammonium nitrate fertilizers	III	Glass	5.0 kg	30 kg G	30 kg	No
		Plastics	5.0 kg			
		Metal	5.0 kg			
		Paper bag	5.0 kg			
		Plastic bag	5.0 kg			
		Fibre	5.0 kg			

OUTER PACKAGINGS OF COMBINATION PACKAGINGS (see 6;3.1)

Boxes

Aluminium
Fibreboard
Natural wood
Other metal
Plastics
Plywood
Reconstituted wood
Steel

Drums

Aluminium
Fibre
Other metal
Plastics
Steel

Jerricans

Aluminium
Plastics
Steel

Packing Instruction 959

Passenger and cargo aircraft for UN 3245 only

General requirements

Part 4, Chapters 1 and 2 requirements must be met, including:

1) Compatibility requirements

- Substances must be compatible with their packagings as required by 4;1.1.3.

2) Closure requirements

- Closures must meet the requirements of 4;1.1.4.

The following packagings are authorized:

- 1) Packagings meeting the provisions of 4;1.1.1, 4;1.1.3.1, 4;1.1.5 and 4;2 and so designed that they meet the construction requirements of 6;3. Outer packagings constructed of suitable material of adequate strength and designed in relation to the packaging capacity and its intended use must be used. Where this packing instruction is used for the transport of inner packagings of combination packagings, the packaging must be designed and constructed to prevent inadvertent discharge during normal conditions of transport.
- 2) Packagings, which need not conform to the packaging test requirements of Part 6, but conforming to the following:
 - a) an inner packaging comprising:
 - 1) primary receptacle(s) and a secondary packaging, the primary receptacle(s) or the secondary packaging must be leakproof for liquids or siftproof for solids;
 - 2) for liquids, absorbent material placed between the primary receptacle(s) and the secondary packaging. The absorbent material must be in a quantity sufficient to absorb the entire contents of the primary receptacle(s) so that any release of the liquid substance will not compromise the integrity of the cushioning material or of the outer packaging;
 - 3) if multiple fragile primary receptacles are placed in a single secondary packaging they must be individually wrapped or separated to prevent contact between them;
 - b) an outer packaging must be strong enough for its capacity, mass and intended use, and with a smallest external dimension of at least 100 mm.

For transport, the mark illustrated below must be displayed on the external surface of the outer packaging on a background of a contrasting colour and must be clearly visible and legible. The mark must be in the form of a square set at an angle of 45° (diamond-shaped) with each side having a length of at least 50 mm; the width of the line must be at least 2 mm and the letters and numbers must be at least 6 mm high.

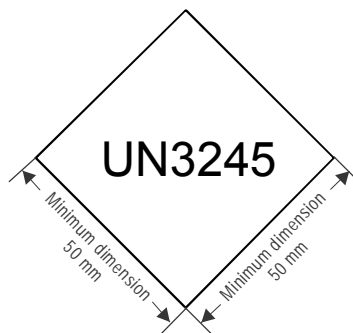

When packages are placed in an overpack, the package markings required by this packing instruction must either clearly be visible or the markings must be reproduced on the outside of the overpack and the overpack must be marked with the word "Overpack".

GMOs or GMMOs assigned to UN 3245 which are packed and marked in accordance with this packing instruction are not subject to any other requirement in these Instructions except for the following:

- 1) the name and address of the shipper and of the consignee must be provided on each package;

- 2) classification must be in accordance with 2;9.2.1 c);
- 3) the incident reporting requirements in 7;4.4 must be met;
- 4) the inspection for damage or leakage requirements in 7;3.1.3 and 7;3.1.4;
- 5) passengers and crew members are prohibited from transporting UN 3245 either as, or in, carry-on baggage or checked baggage or on their person.

ADDITIONAL PACKING REQUIREMENTS

- When dry ice or liquid nitrogen is used, all applicable requirements of these Instructions must be met. When used, ice or dry ice must be placed outside the secondary packagings or in the outer packaging or an overpack. Interior supports must be provided to secure the secondary packagings in the original position after the ice or dry ice has dissipated. If ice is used, the outside packaging or overpack must be leakproof. If dry ice is used, the requirements in Packing Instruction 954 must be met.
- The primary receptacle and the secondary packaging must maintain their integrity at the temperature of the refrigerant used as well as the temperatures and the pressures which could result if refrigeration were lost.

Packing Instruction 960

Passenger and cargo aircraft for UN 3316 only

General requirements

Part 4, Chapter 1 requirements must be met, including:

1) Compatibility requirements

- Substances must be compatible with their packagings as required by 4;1.1.3.

2) Closure requirements

- Closures must meet the requirements of 4;1.1.4.

<i>UN number and proper shipping name</i>	<i>State</i>	<i>Inner packaging* (see 6;3.2)</i>	<i>Maximum quantity of dangerous goods per kit**</i>	<i>Package quantity — passenger</i>	<i>Package quantity — cargo</i>	SINGLE PACKAGINGS
UN 3316 Chemical kit or First aid kit	Liquid	250 mL	1 L	10 kg	10 kg	No
	Solid	250 g	1 kg			

* Containing dangerous goods.

** The total quantity of dangerous goods in any one kit must not exceed 1 L or 1 kg.

ADDITIONAL PACKING REQUIREMENTS

- Kits may contain dangerous goods which require segregation according to Table 7-1.
- Packagings must meet the performance standards of the most stringent packing group assigned to any individual substance contained in the kit. Where the kit contains only dangerous goods to which no packing group is assigned, packagings must meet Packing Group II performance standards.
- Kits must not be packed with other dangerous goods in the same outer packaging, with the exception of dry ice. If dry ice is used, the requirements in Packing Instruction 954 must be met.

OUTER PACKAGINGS OF COMBINATION PACKAGINGS (see 6;3.1)

Boxes

Aluminium (4B)
 Fibreboard (4G)
 Natural wood (4C1, 4C2)
 Other metal (4N)
 Plastics (4H1, 4H2)
 Plywood (4D)
 Reconstituted wood (4F)
 Steel (4A)

Packing Instruction Y960

Limited quantities
Passenger and cargo aircraft for UN 3316 only

General requirements

Part 4, Chapter 1 requirements must be met (except that 4;1.1.2, 1.1.9 c), 1.1.9 e), 1.1.16, 1.1.18 and 1.1.20 do not apply), including:

1) Compatibility requirements

- Substances must be compatible with their packagings as required by 4;1.1.3.

2) Closure requirements

- Closures must meet the requirements of 4;1.1.4.

3) Limited quantity requirements

- Part 3, Chapter 4 requirements must be met except 3;4.3.3, including:
 - the capability of the package to pass a 1.2 m drop test; and
 - a 24-hour stacking test.

<i>UN number and proper shipping name</i>	<i>State</i>	<i>Inner packaging* (see 6;3.2)</i>	<i>Maximum quantity of dangerous goods per kit</i>	<i>Total gross mass per package</i>	SINGLE PACKAGINGS
UN 3316 Chemical kit or First aid kit	Liquid	30 mL	1 kg	30 kg	No
	Solid	100 g			
*Containing dangerous goods.					

ADDITIONAL PACKING REQUIREMENTS FOR COMBINATION PACKAGINGS

- Kits may contain dangerous goods which require segregation according to Table 7-1. The packing group assigned to the kit as a whole must be the most stringent packing group assigned to any individual substance contained in the kit.
- Kits must not be packed with other dangerous goods in the same outer packaging, with the exception of dry ice. If dry ice is used, the requirements in Packing Instruction 954 must be met.
- The total quantity of dangerous goods in any one kit and in any one package must not exceed 1 kg.

OUTER PACKAGINGS OF COMBINATION PACKAGINGS (see 6;3.1)

Boxes

Fibreboard
Natural wood
Other metal
Plastics
Plywood
Reconstituted wood

Packing Instruction 961

Passenger and cargo aircraft for UN 3268 only

General requirements

Part 4, Chapter 1 requirements must be met, including:

1) **Compatibility requirements**

- Substances must be compatible with their packagings as required by 4;1.1.3.

2) **Closure requirements**

- Closures must meet the requirements of 4;1.1.4.

<i>UN number and proper shipping name</i>	<i>Quantity — passenger</i>	<i>Quantity — cargo</i>	SINGLE PACKAGINGS
UN 3268 Safety devices , electrically initiated or Safety devices, pyrotechnic	25 kg	100 kg	No

ADDITIONAL PACKING REQUIREMENTS FOR COMBINATION PACKAGINGS

- Packagings must meet the Packing Group III performance requirements.
- The packagings must be designed and constructed to prevent movement of the articles and inadvertent operation during normal conditions of transport.
- Any pressure receptacle must be in accordance with the requirements of the appropriate national authority for the substance(s) contained therein.

Cargo aircraft only

Air bag inflators, air bag modules and seat-belt pretensioners may also be transported unpackaged on cargo aircraft in dedicated handling devices when transported from where they are manufactured to vehicle assembly plants. When transported in handling devices, the following conditions must be met:

- a) air bag inflators, air bag modules or seat-belt pretensioners as fitted in the handling device must be capable of meeting the test criteria prescribed in Special Provision A115;
- b) the handling device must be completely enclosed;
- c) each air bag inflator, air bag module or seat-belt pretensioner unit must be secured within the handling device to prevent movement in transport; and
- d) irrespective of the limit specified in column 13 of Table 3-1, a handling device meeting these requirements may have a gross mass not exceeding 1 000 kg.

OUTER PACKAGINGS OF COMBINATION PACKAGINGS (see 6;3.1)

Boxes

Aluminium (4B)
Fibreboard (4G)
Natural wood (4C1, 4C2)
Other metal (4N)
Plastics (4H1, 4H2)
Plywood (4D)
Reconstituted wood (4F)
Steel (4A)

Drums

Aluminium (1B2)
Fibre (1G)
Other metal (1N2)
Plastics (1H2)
Plywood (1D)
Steel (1A2)

Jerricans

Aluminium (3B2)
Plastics (3H2)
Steel (3A2)

Packing Instruction 962

Passenger and cargo aircraft for UN 3363 only

General requirements

Part 4, Chapter 1 requirements must be met (except that the requirements of 4;1.1.2, 1.1.9, 1.1.13 and 1.1.16 do not apply), including:

1) Compatibility requirements

- Substances must be compatible with their packagings as required by 4;1.1.3.

2) Closure requirements

- Closures must meet the requirements of 4;1.1.4.

This entry only applies to apparatus or machinery containing dangerous goods as a residue or as an integral element of the machinery or apparatus. It must not be used for apparatus or machinery for which a proper shipping name exists in Table 3-1. For other than fuel system components, apparatus or machinery may only contain one or more of the following: dangerous goods permitted under 3;4.1.2 or UN 2807 or gases of Division 2.2 without subsidiary risk but excluding refrigerated liquefied gases.

<i>UN number and proper shipping name</i>	<i>State</i>	<i>Total net quantity of dangerous goods in one package (excluding magnetic material)</i>
UN 3363 Dangerous goods in apparatus or Dangerous goods in machinery	Liquid	0.5 L
	Solid	1 kg
	Gas (Division 2.2 only)	0.5 kg

ADDITIONAL PACKING REQUIREMENTS

- Receptacles containing dangerous goods must be so secured or cushioned so as to prevent their breakage or leakage and so as to control their movement within the machinery or apparatus during normal conditions of transport. Cushioning material must not react dangerously with the contents of the receptacles. Any leakage of the contents must not substantially impair the protective properties of the cushioning material.
- "Package orientation" labels (Figure 5-27), or preprinted orientation labels meeting the same specification as either Figure 5-27 or ISO Standard 780-1997 must be affixed on at least two opposite vertical sides with the arrows pointing in the correct direction only when required to ensure liquid dangerous goods remain in their intended orientation.
- Irrespective of 5;3.2.10, machinery or apparatus containing magnetized material meeting the requirements of Packing Instruction 953 must also bear the "Magnetized material" label (Figure 5-25).
- For Division 2.2 gases, cylinders for gases, their contents and filling ratios must conform to the requirements of Packing Instruction 200.
- Dangerous goods in apparatus or machinery must be packed in strong outer packagings unless the receptacles containing the dangerous goods are afforded adequate protection by the construction of the apparatus or machinery.

Fuel system components

- Fuel system components must be emptied of fuel as far as practicable and all openings must be sealed securely. They must be packed:
 - 1) in sufficient absorbent material to absorb the maximum amount of liquid which may possibly remain after emptying. Where the outer packaging is not liquid tight, a means of containing the liquid in the event of leakage must be provided in the form of a leakproof liner, plastic bag or other equally efficient means of containment; and
 - 2) in strong outer packagings.

Packing Instruction Y963

Passenger and cargo aircraft for ID 8000 only

Consumer commodities are materials that are packaged and distributed in a form intended or suitable for retail sale for the purposes of personal care or household use. These include items administered or sold to patients by doctors or medical administrations. Except as otherwise provided below, dangerous goods packed in accordance with this packing instruction do not need to comply with 4;1 or Part 6 of these Instructions; they must, however, comply with all other applicable requirements.

- a) Each packaging must be designed and constructed to prevent leakage that may be caused by changes in altitude and temperature during air transport.
- b) Inner packagings that are breakable (such as earthenware, glass or brittle plastic) must be packed to prevent breakage and leakage under conditions normally incident to transport. Each package offered for transport must be capable of withstanding a 1.2 m drop on solid concrete in the position most likely to cause damage. The criteria for passing the test is that the outer packaging must not exhibit any damage liable to affect safety during transport and there must be no leakage from the inner packaging(s). Each package offered for transport must be capable of withstanding, without breakage or leakage of any inner packaging and without significant reduction of effectiveness, a force applied to the top surface for a duration of 24 hours equivalent to the total weight of identical packages if stacked to a height of 3 m (including the test sample).
- c) When filling receptacles for liquids, sufficient ullage (outage) must be left to ensure that neither leakage nor permanent distortion of the receptacle will occur as a result of an expansion of the liquid caused by temperatures likely to prevail during transport. Unless specific requirements are prescribed in national rules or international agreements, liquids must not completely fill a receptacle at a temperature of 55°C. At this temperature a minimum ullage of 2 per cent should be left. The primary packaging (which may include composite packaging), for which retention of the liquid is a basic function, must be capable of withstanding, without leakage, an internal pressure which produces a pressure differential of not less than 75 kPa or a pressure related to the vapour pressure of the liquid to be conveyed, whichever is the greater. The pressure related to the vapour pressure must be determined by the method shown in 4;1.1.6. Tests on sample receptacles must be carried out to demonstrate the capability of the primary packaging to withstand the above pressure.
- d) Stoppers, corks or other such friction-type closures must be held securely, tightly and effectively in place by positive means. The closure device must be so designed that it is extremely improbable that it can be incorrectly or incompletely closed and must be such that it may be easily checked to determine that it is completely closed.
- e) Inner packagings must be tightly packed in strong outer packagings and must be so packed, secured or cushioned so as to prevent any breakage, puncture or leakage of contents into the outer packaging(s) during normal conditions of transport. Absorbent material must be provided for glass or earthenware inner packaging(s) containing consumer commodities in Class 3 or liquids of Division 6.1, in sufficient quantity to absorb the liquid contents of the largest of such inner packagings contained in the outer packaging. Absorbent and cushioning material must not react dangerously with the contents of the inner packagings. Notwithstanding the above, absorbent material may not be required if the inner packagings are so protected that breakage of the inner packagings and leakage of their contents from the outer packaging will not occur during normal conditions of transport.
- f) Inner packagings containing liquids, excluding flammable liquids in inner packagings of 120 mL or less, must be packed with their closures upward and the upright position of the package must be indicated by "Package orientation" labels (Figure 5-27). These labels, or pre-printed package orientation labels meeting the same specification as either Figure 5-27 or ISO Standard 780-1997, must be affixed to, or printed on, at least two opposite vertical sides of the package with the arrows pointing in the correct direction.
- g) Each completed package as prepared for shipment must not exceed a gross mass of 30 kg G.
- h) Class 2 substances must be further limited to aerosol products containing non-toxic compressed or liquefied gas(es) that are necessary to expel liquids, powders or pastes, packed in inner non-refillable non-metal receptacles not exceeding 120 mL capacity each, or in inner non-refillable metal receptacles not exceeding 820 mL capacity each (except that flammable aerosols must not exceed 500 mL capacity each), subject in either case to the following provisions:
 - 1) the pressure in the aerosol must not exceed 1 500 kPa at 55°C and each receptacle must be capable of withstanding, without bursting, a pressure of at least 1.5 times the equilibrium pressure of the contents at 55°C;
 - 2) if the pressure in the aerosol exceeds 970 kPa at 55°C but does not exceed 1 105 kPa at 55°C, an inner IP.7, IP.7A or IP.7B metal receptacle must be used;

- 3) if the pressure in the aerosol exceeds 1 105 kPa at 55°C but does not exceed 1 245 kPa at 55°C, an IP.7A or IP.7B metal receptacle must be used;
 - 4) if the pressure in the aerosol exceeds 1 245 kPa at 55°C, an IP.7B metal receptacle must be used;
 - 5) IP.7B metal receptacles having a minimum burst pressure of 1 800 kPa may be equipped with an inner capsule charged with a non-flammable, non-toxic compressed gas to provide the propellant function. In this case, the pressures indicated in 1), 2), 3) or 4) do not apply to the pressure within the capsule. The quantity of gas contained in the capsule must be so limited such that the minimum burst pressure of the receptacle would not be exceeded if the entire gas content of the capsule were released into an aerosol;
 - 6) the liquid contents must not completely fill the closed receptacle at 55°C;
 - 7) each aerosol exceeding 120 mL capacity must have been heated until the pressure in the aerosol is equivalent to the equilibrium pressure of the contents at 55°C, without evidence of leakage, distortion or other defect; and
 - 8) the valves must be protected by a cap or other suitable means during transport.
- i) For aerosols containing a biological or medical preparation which will be deteriorated by a heat test and which are non-toxic and non-flammable, packed in inner non-refillable receptacles not exceeding 575 mL capacity each, the following provisions are applicable:
- 1) the pressure in the aerosol must not exceed 970 kPa at 55°C;
 - 2) the liquid contents must not completely fill the closed receptacle at 55°C;
 - 3) one aerosol out of each lot of 500 or less must be heated until the pressure in the aerosol is equivalent to the equilibrium pressure of the contents at 55°C, without evidence of leakage, distortion or other defect; and
 - 4) the valves must be protected by a cap or other suitable means during transport.
- j) Except for aerosols, inner packagings must not exceed:
- 1) 500 mL for liquids; and
 - 2) 500 g for solids.
- k) Consumer commodities shipped according to these provisions may be shipped in a unit load device or other type of pallet prepared by a single shipper provided they contain no other dangerous goods. The shipper must provide the operator with written documentation stating the number of packages of consumer commodities contained in each unit load device or other type of pallet.
- l) The gross mass on the dangerous goods transport document must be shown as:
- 1) for one package, the actual gross mass of the package;
 - 2) for more than one package, either the actual gross mass of each package or as the average mass of the packages. (For example, if there are 10 packages and the total gross mass of them is 100 kg, the dangerous goods transport document may show this as "average gross mass per package 10 kg".)
- m) Packages prepared in accordance with these provisions must be durably and legibly marked with the mark shown in Figure 3-1.

Packing Instruction 964

Passenger and cargo aircraft for UN 1941, UN 1990, UN 2315, UN 3151, UN 3082 and UN 3334 only

General requirements

Except for UN 3082 when the requirements of 4;1.1.6 do not apply, Part 4, Chapter 1 requirements must be met, including:

1) Compatibility requirements

- Substances must be compatible with their packagings as required by 4;1.1.3.

2) Closure requirements

- Closures must meet the requirements of 4;1.1.4.

COMBINATION PACKAGINGS					SINGLE PACKAGINGS	
<i>UN number and proper shipping name</i>	<i>Inner packaging (see 6;3.2)</i>	<i>Inner packaging quantity (per receptacle)</i>	<i>Total quantity per package — passenger</i>	<i>Total quantity per package — cargo</i>	<i>Passenger</i>	<i>Cargo</i>
UN 1941 Dibromodifluoromethane	Glass	10.0 L	100 L	220 L	100 L	220 L
	Plastics	30.0 L				
	Metal	40.0 L				
UN 1990 Benzaldehyde	Glass	10.0 L	100 L	220 L	100 L	220 L
	Plastics	30.0 L				
	Metal	40.0 L				
UN 2315 Polychlorinated biphenyls, liquid	Glass	10.0 L	100 L	220 L	100 L	220 L
	Plastics	30.0 L				
	Metal	40.0 L				
UN 3082 Environmentally hazardous substance, liquid, n.o.s.	Glass	10.0 L	450 L	450 L	450 L	450 L
	Plastics	30.0 L				
	Metal	40.0 L				
UN 3151 Polyhalogenated biphenyls, liquid or Polyhalogenated terphenyls, liquid	Glass	10.0 L	100 L	220 L	100 L	220 L
	Plastics	30.0 L				
	Metal	40.0 L				
UN 3334 Aviation regulated liquid, n.o.s.	Glass	10.0 L	450 L	450 L	450 L	450 L
	Plastics	30.0 L				
	Metal	40.0 L				

OUTER PACKAGINGS OF COMBINATION PACKAGINGS (see 6;3.1)

Boxes

Aluminium (4B)
Fibreboard (4G)
Natural wood (4C1, 4C2)
Other metal (4N)
Plastics (4H1, 4H2)
Plywood (4D)
Reconstituted wood (4F)
Steel (4A)

Drums

Aluminium (1B1, 1B2)
Fibre (1G)
Other metal (1N1, 1N2)
Plastics (1H1, 1H2)
Steel (1A1, 1A2)

Jerricans

Aluminium (3B1, 3B2)
Plastics (3H1, 3H2)
Steel (3A1, 3A2)

SINGLE PACKAGINGS

Composites

All (see 6;3.1.18)

Cylinders

See 4;2.7

Drums

Aluminium (1B1, 1B2)
Other metal (1N1, 1N2)
Plastics (1H1, 1H2)
Steel (1A1, 1A2)

Jerricans

Aluminium (3B1, 3B2)
Plastics (3H1, 3H2)
Steel (3A1, 3A2)

Packing Instruction Y964

Limited quantities
Passenger and cargo aircraft for UN 1941, UN 1990, UN 3082 and UN 3334 only

General requirements

Except for UN 3082 when the requirements of 4;1.1.6 do not apply, Part 4, Chapter 1 requirements must be met (except that 4;1.1.2, 1.1.9 c), 1.1.9 e), 1.1.16, 1.1.18 and 1.1.20 do not apply), including:

1) Compatibility requirements

- Substances must be compatible with their packagings as required by 4;1.1.3.

2) Closure requirements

- Closures must meet the requirements of 4;1.1.4.

3) Limited quantity requirements

- Part 3, Chapter 4 requirements must be met including:
 - the capability of the package to pass a 1.2 m drop test;
 - a 24-hour stacking test; and
 - inner packagings for liquids must be capable of passing a pressure differential test (4;1.1.6).

COMBINATION PACKAGINGS					SINGLE PACKAGINGS
<i>UN number and proper shipping name</i>	<i>Inner packaging (see 6;3.2)</i>	<i>Inner packaging quantity (per receptacle)</i>	<i>Total quantity per package</i>	<i>Total gross mass per package</i>	
UN 1941 Dibromodifluoromethane	Glass	5.0 L	30 kg	30 kg	No
UN 1990 Benzaldehyde	Plastics	5.0 L			
UN 3082 Environmentally hazardous substance, liquid, n.o.s.	Metal	5.0 L			
UN 3334 Aviation regulated liquid, n.o.s.*					

OUTER PACKAGINGS OF COMBINATION PACKAGINGS (see 6;3.1)

Boxes

Aluminium
Fibreboard
Natural wood
Other metal
Plastics
Plywood
Reconstituted wood
Steel

Drums

Aluminium
Fibre
Other metal
Plastics
Steel

Jerricans

Aluminium
Plastics
Steel

Packing Instruction 965

Passenger and cargo aircraft for UN 3480

1. Introduction

This entry applies to lithium ion or lithium polymer batteries. This packing instruction is structured as follows:

- Section IA applies to lithium ion cells with a Watt-hour rating in excess of 20 Wh and lithium ion batteries with a Watt-hour rating in excess of 100 Wh, which must be assigned to Class 9 and are subject to all of the applicable requirements of these Instructions;
- Section IB applies to lithium ion cells with a Watt-hour rating not exceeding 20 Wh and lithium ion batteries with a Watt-hour rating not exceeding 100 Wh packed in quantities that exceed the allowance permitted in Section II, Table 965-II; and
- Section II applies to lithium ion cells with a Watt-hour rating not exceeding 20 Wh and lithium ion batteries with a Watt-hour rating not exceeding 100 Wh packed in quantities not exceeding the allowance permitted in Section II, Table 965-II.

2. Lithium batteries forbidden from transport

The following applies to all lithium ion cells and batteries in this packing instruction:

Cells and batteries, identified by the manufacturer as being defective for safety reasons, or that have been damaged, that have the potential of producing a dangerous evolution of heat, fire or short circuit are forbidden for transport (e.g. those being returned to the manufacturer for safety reasons).

Waste lithium batteries and lithium batteries being shipped for recycling or disposal are forbidden from air transport unless approved by the appropriate national authority of the State of Origin and the State of the Operator.

IA. SECTION IA

Each cell or battery must meet all the provisions of 2;9.3.

1A.1 General requirements

Part 4;1 requirements must be met.

Table 965-IA

<i>UN number and proper shipping name</i>	<i>Net quantity per package</i>	
	<i>Passenger</i>	<i>Cargo</i>
UN 3480 Lithium ion batteries	5 kg	35 kg

V

V

Packing Instruction 965

IA.2 Additional requirements

- Lithium ion cells and batteries must be protected against short circuits.
- Lithium ion cells and batteries must be placed in inner packagings that completely enclose the cell or battery then placed in an outer packaging. The completed package for the cells or batteries must meet the Packing Group II performance requirements.
- Lithium ion batteries with a mass of 12 kg or greater and having a strong, impact-resistant outer casing, or assemblies of such batteries, may be transported when packed in strong outer packagings or protective enclosures (e.g. in fully enclosed or wooden slatted crates) not subject to the requirements of Part 6 of these Instructions, if approved by the appropriate authority of the State of Origin. A copy of the document of approval must accompany the consignment.
- Batteries manufactured after 31 December 2011 must be marked with the Watt-hour rating on the outside case.

IA.3 Outer packagings

Boxes

Aluminium (4B)
Fibreboard (4G)
Natural wood (4C1, 4C2)
Other metal (4N)
Plastics (4H1, 4H2)
Plywood (4D)
Reconstituted wood (4F)
Steel (4A)

Drums

Aluminium (1B2)
Fibre (1G)
Other metal (1N2)
Plastics (1H2)
Plywood (1D)
Steel (1A2)

Jerricans

Aluminium (3B2)
Plastics (3H2)
Steel (3A2)

IB. SECTION IB

Quantities of lithium ion cells or batteries that exceed the allowance permitted in Section II, Table 965-II are subject to all of the applicable provisions of these Instructions (including the requirements in paragraph 2 of this packing instruction and of this section) except for the the provisions of Part 6.

Lithium ion cells or batteries shipped in accordance with the provisions of Section IB must be described on a dangerous goods transport document as set in Part 5;4. The packing instruction number "965" required by 5;4.1.5.8.1 a) must be supplemented with "IB". All other applicable provisions of Part 5;4 apply.

Lithium ion cells and batteries may be offered for transport provided that each cell and battery meets the provisions of 2;9.3.1 a) and e) and the following:

- 1) for lithium ion cells, the Watt-hour rating (see the Glossary of Terms in Attachment 2) is not more than 20 Wh;
- 2) for lithium ion batteries, the Watt-hour rating is not more than 100 Wh;
 - the Watt-hour rating must be marked on the outside of the battery case except for those batteries manufactured before 1 January 2009;

IB.1 General requirements

Cells and batteries must be packed in strong outer packagings that conform to Part 4;1.1.1, 1.1.3.1 and 1.1.10 (except 1.1.10.1).

Table 965-IB

≠	<i>Contents</i>	<i>Net quantity per package</i>	
		<i>Passenger</i>	<i>Cargo</i>
	Lithium ion cells and batteries	10 kg	10 kg

Packing Instruction 965

IB.2 Additional requirements

- Cells and batteries must be packed in inner packagings that completely enclose the cell or battery then placed in a strong outer packaging.
- Cells and batteries must be protected so as to prevent short circuits. This includes protection against contact with conductive materials within the same packaging that could lead to a short circuit.
- Each package must be capable of withstanding a 1.2 m drop test in any orientation without:
 - damage to cells or batteries contained therein;
 - shifting of the contents so as to allow battery to battery (or cell to cell) contact;
 - release of contents.
- Each package must be labelled with a lithium battery handling label (Figure 5-32) in addition to the Class 9 hazard label.
- Each consignment must be accompanied with a document with an indication that:
 - the package contains lithium ion cells or batteries;
 - the package must be handled with care and that a flammability hazard exists if the package is damaged;
 - special procedures must be followed in the event the package is damaged, to include inspection and repacking if necessary; and
 - a telephone number for additional information.

Note.— This information may be provided on the dangerous goods transport document.

IB.3 Outer packagings

Boxes

Drums

Jerricans

Strong outer packagings

II. SECTION II

With the exception of Part 1;2.3 (General — Transport of dangerous goods by post), 7;4.4 (Operator's responsibilities — Reporting of dangerous goods accidents and incidents), 8;1.1 (Provisions concerning passengers and crew — Dangerous goods carried by passengers or crew) and paragraph 2 of this packing instruction, lithium ion cells and batteries offered for transport are not subject to other additional requirements of these Instructions if they meet the requirements of this section.

- ≠ Lithium ion cells and batteries may be offered for transport provided that each cell and battery meets the provisions of 2;9.3.1 a) and e) and the following:
- 1) for lithium ion cells, the Watt-hour rating (see the Glossary of Terms in Attachment 2) is not more than 20 Wh;
 - 2) for lithium ion batteries, the Watt-hour rating is not more than 100 Wh;
 - the Watt-hour rating must be marked on the outside of the battery case except for those batteries manufactured before 1 January 2009.

>

Packing Instruction 965

II.1 General requirements

Cells and batteries must be packed in strong outer packagings that conform to Part 4;1.1.1, 1.1.3.1 and 1.1.10 (except 1.1.10.1).

Table 965-II

<i>Contents</i>	<i>Lithium ion cells and/or batteries with a Watt-hour rating not more than 2.7 Wh</i>	<i>Lithium ion cells with a Watt-hour rating more than 2.7 Wh, but not more than 20 Wh</i>	<i>Lithium ion batteries with a Watt-hour rating more than 2.7 Wh, but not more than 100 Wh</i>
1	2	3	4
Maximum number of cells / batteries per package	No limit	8 cells	2 batteries
Maximum net quantity (mass) per package	2.5 kg	n/a	n/a

The limits specified in columns 2, 3 and 4 of Table 965-II must not be combined in the same package.

II.2 Additional requirements

- Cells and batteries must be packed in inner packagings that completely enclose the cell or battery then placed in a strong outer packaging.
- Cells and batteries must be protected so as to prevent short circuits. This includes protection against contact with conductive materials within the same packaging that could lead to a short circuit.
- Each package must be capable of withstanding a 1.2 m drop test in any orientation without:
 - damage to cells or batteries contained therein;
 - shifting of the contents so as to allow battery to battery (or cell to cell) contact;
 - release of contents.
- Each package must be labelled with a lithium battery handling label (Figure 5-32).
- Each consignment must be accompanied with a document with an indication that:
 - the package contains lithium ion cells or batteries;
 - the package must be handled with care and that a flammability hazard exists if the package is damaged;
 - special procedures must be followed in the event the package is damaged, to include inspection and repacking if necessary; and
 - a telephone number for additional information.
- The words "lithium ion batteries, in compliance with Section II of PI965" must be placed on the air waybill, when an air waybill is used.
- Any person preparing or offering cells or batteries for transport must receive adequate instruction on these requirements commensurate with their responsibilities.

II.3 Outer packagings

Boxes

Drums

Jerricans

Strong outer packagings

II.4 Overpacks

When packages are placed in an overpack, the lithium battery handling label required by this packing instruction must either be clearly visible or the label must be affixed on the outside of the overpack and the overpack must be marked with the word "Overpack".

Packing Instruction 966

Passenger and cargo aircraft for UN 3481 (packed with equipment) only

1. Introduction

This entry applies to lithium ion or lithium polymer batteries packed with equipment.

Section I of this packing instruction applies to lithium ion and lithium polymer cells and batteries that are assigned to Class 9. Certain lithium ion and lithium polymer cells and batteries offered for transport and meeting the requirements of Section II of this packing instruction, subject to paragraph 2 below, are not subject to other additional requirements of these Instructions.

2. Lithium batteries forbidden from transport

The following applies to all lithium ion cells and batteries in this packing instruction:

Cells and batteries, identified by the manufacturer as being defective for safety reasons, or that have been damaged, that have the potential of producing a dangerous evolution of heat, fire or short circuit are forbidden for transport (e.g. those being returned to the manufacturer for safety reasons).

I. SECTION I

Each cell or battery must meet all the provisions of 2;9.3.

I.1 General requirements

Part 4;1 requirements must be met.

<i>UN number and proper shipping name</i>	<i>Package quantity (Section I)</i>	
	<i>Passenger</i>	<i>Cargo</i>
UN 3481 Lithium ion batteries packed with equipment	5 kg of lithium ion cells or batteries	35 kg of lithium ion cells or batteries

>
≠
>

Packing Instruction 966

I.2 Additional requirements

- Lithium ion cells and batteries must be protected against short circuits.
- Lithium ion cells or batteries must:
 - be placed in inner packagings that completely enclose the cell or battery then placed in an outer packaging. The completed package for the cells or batteries must meet the Packing Group II performance requirements; or
 - be placed in inner packagings that completely enclose the cell or battery, then placed with equipment in a packaging that meets the Packing Group II performance requirements.
- The equipment must be secured against movement within the outer packaging and must be equipped with an effective means of preventing accidental activation.
- The number of cells or batteries in each package must not exceed the appropriate number for the equipment's operation, plus two spares.
- For the purpose of this packing instruction, "equipment" means apparatus requiring the lithium ion batteries with which it is packed for its operation.
- Batteries manufactured after 31 December 2011 must be marked with the Watt-hour rating on the outside case.

I.3 Outer packagings

<i>Boxes</i>	<i>Drums</i>	<i>Jerricans</i>
Aluminium (4B)	Aluminium (1B2)	Aluminium (3B2)
Fibreboard (4G)	Fibre (1G)	Plastics (3H2)
Natural wood (4C1, 4C2)	Other metal (1N2)	Steel (3A2)
Other metal (4N)	Plastics (1H2)	
Plastics (4H1, 4H2)	Plywood (1D)	
Plywood (4D)	Steel (1A2)	
Reconstituted wood (4F)		
Steel (4A)		

II. SECTION II

With the exception of Part 1;2.3 (Transport of dangerous goods by post), 7;4.4 (Reporting of dangerous goods accidents and incidents), 8;1.1 (Dangerous goods carried by passengers or crew) and paragraph 2 of this packing instruction, lithium ion cells and batteries packed with equipment offered for transport are not subject to other additional requirements of these Instructions if they meet the requirements of this section.

Lithium ion cells and batteries may be offered for transport provided that each cell and battery meets the provisions of 2;9.3.1 a) and e) and the following:

- 1) for lithium ion cells, the Watt-hour rating (see the Glossary of Terms in Attachment 2) is not more than 20 Wh;
- 2) for lithium ion batteries, the Watt-hour rating is not more than 100 Wh;
 - the Watt-hour rating must be marked on the outside of the battery case except for those batteries manufactured before 1 January 2009.

II.1 General requirements

Cells and batteries must be packed in strong outer packagings that conform to Part 4;1.1.1, 1.1.3.1 and 1.1.10 (except 1.1.10.1).

<i>Contents</i>	<i>Package quantity (Section II)</i>	
	<i>Passenger</i>	<i>Cargo</i>
Net quantity of lithium ion cells or batteries per package	5 kg	5 kg

Packing Instruction 966

II.2 Additional requirements

- Lithium ion cells and batteries must:
 - be placed in inner packagings that completely enclose the cell or battery, then placed in a strong outer packaging; or
 - be placed in inner packagings that completely enclose the cell or battery, then placed with the equipment in a strong outer packaging.
- Cells and batteries must be protected so as to prevent short circuits. This includes protection against contact with conductive materials within the same packaging that could lead to a short circuit.
- The equipment must be secured against movement within the outer packaging and must be equipped with an effective means of preventing accidental activation.
- The number of cells or batteries in each package must not exceed the appropriate number for the equipment's operation, plus two spares.
- Each package of cells or batteries, or the completed package, must be capable of withstanding a 1.2 m drop test in any orientation without:
 - damage to cells or batteries contained therein;
 - shifting of the contents so as to allow battery to battery (or cell to cell) contact;
 - release of contents.
- Each package must be labelled with a lithium battery handling label (Figure 5-32).
- Each consignment must be accompanied with a document with an indication that:
 - the package contains lithium ion cells or batteries;
 - the package must be handled with care and that a flammability hazard exists if the package is damaged;
 - special procedures must be followed in the event the package is damaged, to include inspection and repacking if necessary; and
 - a telephone number for additional information.
- The words "lithium ion batteries, in compliance with Section II of PI966" must be placed on the air waybill, when an air waybill is used.
- Any person preparing or offering cells or batteries for transport must receive adequate instruction on these requirements commensurate with their responsibilities.

II.3 Outer packagings

Boxes

Drums

Jerricans

Strong outer packagings

II.4 Overpacks

When packages are placed in an overpack, the lithium battery handling label required by this packing instruction must either be clearly visible or the label must be affixed on the outside of the overpack and the overpack must be marked with the word "Overpack".

Packing Instruction 967

Passenger and cargo aircraft for UN 3481 (contained in equipment) only

1. Introduction

This entry applies to lithium ion or lithium polymer batteries contained in equipment.

Section I of this packing instruction applies to lithium ion and lithium polymer cells and batteries that are assigned to Class 9. Certain lithium ion and lithium polymer cells and batteries offered for transport and meeting the requirements of Section II of this packing instruction, subject to paragraph 2 below, are not subject to other additional requirements of these Instructions.

2. Lithium batteries forbidden from transport

The following applies to all lithium ion cells and batteries in this packing instruction:

Cells and batteries, identified by the manufacturer as being defective for safety reasons, or that have been damaged, that have the potential of producing a dangerous evolution of heat, fire or short circuit are forbidden for transport (e.g. those being returned to the manufacturer for safety reasons).

Packing Instruction 967

I. SECTION I

Each cell or battery must meet all the provisions of 2;9.3.

I.1 General requirements

Equipment must be packed in strong outer packagings that conform to Part 4;1.1.1, 1.1.3.1 and 1.1.10 (except 1.1.10.1).

<i>UN number and proper shipping name</i>	<i>Package quantity (Section I)</i>	
	<i>Passenger</i>	<i>Cargo</i>
UN 3481 Lithium ion batteries contained in equipment	5 kg of lithium ion cells or batteries	35 kg of lithium ion cells or batteries

I.2 Additional requirements

- The equipment must be secured against movement within the outer packaging and be packed so as to prevent accidental operation during air transport.
- The equipment must be packed in strong outer packagings constructed of suitable material of adequate strength and design in relation to the packaging's capacity and its intended use unless the battery is afforded equivalent protection by the equipment in which it is contained.
- Batteries manufactured after 31 December 2011 must be marked with the Watt-hour rating on the outside case.

I.3 Outer packagings

Boxes

Drums

Jerricans

Strong outer packagings

II. SECTION II

With the exception of Part 1;2.3 (Transport of dangerous goods by post), 7;4.4 (Reporting of dangerous goods accidents and incidents), 8;1.1 (Dangerous goods carried by passengers or crew) and paragraph 2 of this packing instruction, lithium ion cells and batteries contained in equipment offered for transport are not subject to other additional requirements of these Instructions if they meet the requirements of this section.

Lithium ion cells and batteries may be offered for transport provided that each cell and battery meets the provisions of 2;9.3.1 a) and e) and the following:

- 1) for lithium ion cells, the Watt-hour rating (see the Glossary of Terms in Attachment 2) is not more than 20 Wh;
- 2) for lithium ion batteries, the Watt-hour rating is not more than 100 Wh;
 - the Watt-hour rating must be marked on the outside of the battery case except for those batteries manufactured before 1 January 2009.

Packing Instruction 967

Devices such as radio frequency identification (RFID) tags, watches and temperature loggers, which are not capable of generating a dangerous evolution of heat, may be transported when intentionally active. When active, these devices must meet defined standards for electromagnetic radiation to ensure that the operation of the device does not interfere with aircraft systems. The devices must not be capable of emitting disturbing signals (such as buzzing alarms, strobe lights, etc.) during transport.

II.1 General requirements

Equipment must be packed in strong outer packagings that conform to Part 4;1.1.1, 1.1.3.1 and 1.1.10 (except 1.1.10.1).

<i>Contents</i>	<i>Package quantity (Section II)</i>	
	<i>Passenger</i>	<i>Cargo</i>
Net quantity of lithium ion cells or batteries per package	5 kg	5 kg

II.2 Additional requirements

- The equipment must be secured against movement within the outer packaging and must be equipped with an effective means of preventing accidental activation.
- Cells and batteries must be protected so as to prevent short circuits.
- The equipment must be packed in strong outer packagings constructed of suitable material of adequate strength and design in relation to the packaging's capacity and its intended use unless the battery is afforded equivalent protection by the equipment in which it is contained.
- Each package containing more than four cells or more than two batteries installed in equipment must be labelled with a lithium battery handling label (Figure 5-32) (except button cell batteries installed in equipment (including circuit boards)).
- Each consignment with packages bearing the lithium battery handling label must be accompanied with a document with an indication that:
 - the package contains lithium ion cells or batteries;
 - the package must be handled with care and that a flammability hazard exists if the package is damaged;
 - special procedures must be followed in the event the package is damaged, to include inspection and repacking if necessary; and
 - a telephone number for additional information.
- Where a consignment includes packages bearing the lithium battery handling label, the words "lithium ion batteries, in compliance with Section II of PI967" must be placed on the air waybill, when an air waybill is used.
- Any person preparing or offering cells or batteries for transport must receive adequate instruction on these requirements commensurate with their responsibilities.

II.3 Outer packagings

Boxes

Drums

Jerricans

Strong outer packagings

II.4 Overpacks

When packages are placed in an overpack, the lithium battery handling label required by this packing instruction must either be clearly visible or the label must be affixed on the outside of the overpack and the overpack must be marked with the word "Overpack".

#

Packing Instruction 968

Cargo aircraft only for UN 3090

1. Introduction

This entry applies to lithium metal or lithium alloy batteries. This packing instruction is structured as follows:

- Section IA applies to lithium metal cells with a lithium metal content in excess of 1 g and lithium metal batteries with a lithium metal content in excess of 2 g, which must be assigned to Class 9 and are subject to all of the applicable requirements of these Instructions;
- Section IB applies to lithium metal cells with a lithium metal content not exceeding 1 g and lithium metal batteries with a lithium metal content not exceeding 2 g packed in quantities that exceed the allowance permitted in Section II, Table 968-II; and
- Section II applies to lithium metal cells with a lithium metal content not exceeding 1 g and lithium metal batteries with a lithium metal content not exceeding 2 g packed in quantities not exceeding the allowance permitted in Section II, Table 968-II.

2. Lithium batteries forbidden from transport

The following applies to all lithium metal cells and batteries in this packing instruction:

Cells and batteries, identified by the manufacturer as being defective for safety reasons, or that have been damaged, that have the potential of producing a dangerous evolution of heat, fire or short circuit are forbidden for transport (e.g. those being returned to the manufacturer for safety reasons).

Waste lithium batteries and lithium batteries being shipped for recycling or disposal are forbidden from air transport unless approved by the appropriate national authority of the State of Origin and the State of the Operator.

IA. SECTION IA

Each cell or battery must meet all the provisions of 2;9.3.

IA.1 General requirements

Part 4;1 requirements must be met.

Table 968-IA

	<i>UN number and proper shipping name</i>	<i>Net quantity per package</i>	
		<i>Passenger</i>	<i>Cargo</i>
#	UN 3090 Lithium metal batteries	Forbidden	35 kg

#

Packing Instruction 968

IA.2 Additional requirements

- Lithium metal cells and batteries must be protected against short circuits.
- Lithium metal cells and batteries must be placed in inner packagings that completely enclose the cell or battery, then placed in an outer packaging. The completed package for the cells or batteries must meet the Packing Group II performance requirements.
- Lithium metal batteries with a mass of 12 kg or greater and having a strong, impact-resistant outer casing, or assemblies of such batteries, may be transported when packed in strong outer packagings or protective enclosures (e.g. in fully enclosed or wooden slatted crates) not subject to the requirements of Part 6 of these Instructions, if approved by the appropriate authority of the State of Origin. A copy of the document of approval must accompany the consignment.

IA.3 Outer packagings

<i>Boxes</i>	<i>Drums</i>	<i>Jerricans</i>
Aluminium (4B)	Aluminium (1B2)	Aluminium (3B2)
Fibreboard (4G)	Fibre (1G)	Plastics (3H2)
Natural wood (4C1, 4C2)	Other metal (1N2)	Steel (3A2)
Other metal (4N)	Plastics (1H2)	
Plastics (4H1, 4H2)	Plywood (1D)	
Plywood (4D)	Steel (1A2)	
Reconstituted wood (4F)		
Steel (4A)		

IB. SECTION IB

Quantities of lithium metal cells or batteries that exceed the allowance permitted in Section II, Table 968-II, are subject to all of the applicable provisions of these Instructions (including the requirements in paragraph 2 of this packing instruction and of this section) except for the provisions of Part 6.

Lithium metal cells or batteries shipped in accordance with the provisions of Section IB must be described on a dangerous goods transport document as set in Part 5;4. The packing instruction number "968" required by 5;4.1.5.8.1 a) must be supplemented with "IB". All other applicable provisions of Part 5;4 apply.

Lithium metal or lithium alloy cells and batteries may be offered for transport provided that each cell and battery meets the provisions of 2;9.3.1 a) and e) and the following:

- 1) for lithium metal cells, the lithium content is not more than 1 g;
- 2) for lithium metal or lithium alloy batteries, the aggregate lithium content is not more than 2 g.

Packing Instruction 968

IB.1 General requirements

Cells and batteries must be packed in strong outer packagings that conform to Part 4;1.1.1, 1.1.3.1 and 1.1.10 (except 1.1.10.1).

Table 968-IB

≠ ≠	Contents	Net quantity per package	
		Passenger	Cargo
	Lithium metal cells and batteries	Forbidden	2.5 kg

IB.2 Additional requirements

- Cells and batteries must be packed in inner packagings that completely enclose the cell or battery then placed in a strong outer packaging.
- Cells and batteries must be protected so as to prevent short circuits. This includes protection against contact with conductive materials within the same packaging that could lead to a short circuit.
- Each package must be capable of withstanding a 1.2 m drop test in any orientation without:
 - damage to cells or batteries contained therein;
 - shifting of the contents so as to allow battery to battery (or cell to cell) contact;
 - release of contents.
- Each package must be labelled with a lithium battery handling label (Figure 5-32) in addition to the Class 9 hazard label and the cargo aircraft only label (Figure 5-26).
- Each consignment must be accompanied with a document with an indication that:
 - the package contains lithium metal cells or batteries;
 - the package must be handled with care and that a flammability hazard exists if the package is damaged;
 - special procedures must be followed in the event the package is damaged, to include inspection and repacking if necessary; and
 - a telephone number for additional information.

Note.— This information may be provided on the dangerous goods transport document.

IB.3 Outer packagings

Boxes

Drums

Jerricans

Strong outer packagings

II. SECTION II

With the exception of Part 1;2.3 (General — Transport of dangerous goods by post), 5;1.1 g), 5;1.1 j) (Shipper's responsibilities — General requirements), 7;2.1 (Operator's responsibilities — Loading restrictions on the flight deck and for passenger aircraft), 7;2.4.1 (Operator's responsibilities — Loading of cargo aircraft), 7;4.4 (Operator's responsibilities — Reporting of dangerous goods accidents and incidents), 8;1.1 (Provisions concerning passengers and crew — Dangerous goods carried by passengers or crew) and paragraph 2 of this packing instruction, lithium metal or lithium alloy cells and batteries offered for transport are not subject to other additional requirements of these Instructions if they meet the requirements of this section.

Lithium metal or lithium alloy cells and batteries may be offered for transport provided that each cell and battery meets the provisions of 2;9.3.1 a) and e) and the following:

- 1) for a lithium metal cell, the lithium content is not more than 1 g;
- 2) for a lithium metal or lithium alloy battery, the aggregate lithium content is not more than 2 g.

II.1 General requirements

Cells and batteries must be packed in strong outer packagings that conform to Part 4;1.1.1, 1.1.3.1 and 1.1.10 (except 1.1.10.1).

Packing Instruction 968

Table 968-II

<i>Contents</i>	<i>Lithium metal cells and/or batteries with a lithium content not more than 0.3 g</i>	<i>Lithium metal cells with a lithium content more than 0.3 g but not more than 1 g</i>	<i>Lithium metal batteries with a lithium content more than 0.3 g but not more than 2 g</i>
1	2	3	4
Maximum number of cells / batteries per package	No limit	8 cells	2 batteries
Maximum net quantity (mass) per package	2.5 kg	n/a	n/a

The limits specified in columns 2, 3 and 4 of Table 968-II must not be combined in the same package.

II.2 Additional requirements

- Cells and batteries must be packed in inner packagings that completely enclose the cell or battery, then placed in a strong outer packaging.
- Cells and batteries must be protected so as to prevent short circuits. This includes protection against contact with conductive materials within the same packaging that could lead to a short circuit.
- Each package must be capable of withstanding a 1.2 m drop test in any orientation without:
 - damage to cells or batteries contained therein;
 - shifting of the contents so as to allow battery to battery (or cell to cell) contact;
 - release of contents.
- Each package must be labelled with a lithium battery handling label (Figure 5-32) and the cargo aircraft only label (Figure 5-26).
 - the cargo aircraft only label must be located on the same surface of the package near the lithium battery handling label, if the package dimensions are adequate.
- Each consignment must be accompanied with a document with an indication that:
 - the package contains lithium metal cells or batteries;
 - the package must be handled with care and that a flammability hazard exists if the package is damaged;
 - special procedures must be followed in the event the package is damaged, to include inspection and repacking if necessary; and
 - a telephone number for additional information.
- The words "lithium metal batteries, in compliance with Section II of PI968 — cargo aircraft only" or "lithium metal batteries, in compliance with Section II of PI968 — CAO" must be placed on the air waybill, when an air waybill is used.
- Consignments of lithium metal batteries prepared in accordance with the provisions of Section II must not be consolidated with other shipments of dangerous goods or non-dangerous goods and must not be loaded into a unit load device before being offered to the operator.
- Any person preparing or offering cells or batteries for transport must receive adequate instruction on these requirements commensurate with their responsibilities.

II.3 Outer packagings

Boxes

Drums

Jerricans

Strong outer packagings

II.4 Overpacks

When packages are placed in an overpack, the lithium battery handling label and the cargo aircraft only label (Figure 5-26) required by this packing instruction must either be clearly visible or the labels must be affixed on the outside of the overpack and the overpack must be marked with the word "Overpack".

Packing Instruction 969

Passenger and cargo aircraft for UN 3091 (packed with equipment) only

1. Introduction

This entry applies to lithium metal or lithium alloy batteries packed with equipment.

Section I of this packing instruction applies to lithium metal and lithium alloy cells and batteries that are assigned to Class 9. Certain lithium metal and lithium alloy cells and batteries offered for transport and meeting the requirements of Section II of this packing instruction, subject to paragraph 2 below, are not subject to other additional requirements of these Instructions.

2. Lithium batteries forbidden from transport

The following applies to all lithium metal cells and batteries in this packing instruction:

Cells and batteries, identified by the manufacturer as being defective for safety reasons, or that have been damaged, that have the potential of producing a dangerous evolution of heat, fire or short circuit are forbidden for transport (e.g. those being returned to the manufacturer for safety reasons).

I. SECTION I

Each cell or battery must meet all the provisions of 2;9.3.

I.1 General requirements

Part 4;1 requirements must be met.

<i>UN number and proper shipping name</i>	<i>Package quantity (Section I)</i>	
	<i>Passenger</i>	<i>Cargo</i>
UN 3091 Lithium metal batteries packed with equipment	5 kg of lithium metal cells or batteries	35 kg of lithium metal cells or batteries

Packing Instruction 969

I.2 Additional requirements

- Lithium metal cells and batteries must be protected against short circuits.
- Lithium metal cells or batteries must:
 - be placed in inner packagings that completely enclose the cell or battery, then placed in an outer packaging. The completed package for the cells or batteries must meet the Packing Group II performance requirements; or
 - be placed in inner packagings that completely enclose the cell or battery, then placed with equipment in a packaging that meets the Packing Group II performance requirements.
- The equipment must be secured against movement within the outer packaging and must be equipped with an effective means of preventing accidental activation.
- The number of cells or batteries in each package must not exceed the appropriate number for the equipment's operation, plus two spares.
- For the purpose of this packing instruction, "equipment" means apparatus requiring the lithium batteries with which it is packed for its operation.
- For lithium metal cells and batteries prepared for transport on passenger aircraft as Class 9:
 - cells and batteries offered for transport on passenger aircraft must be packed in intermediate or outer rigid metal packaging surrounded by cushioning material that is non-combustible and non-conductive and placed inside an outer packaging.

I.3 Outer packagings

<i>Boxes</i>	<i>Drums</i>	<i>Jerricans</i>
Aluminium (4B)	Aluminium (1B2)	Aluminium (3B2)
Fibreboard (4G)	Fibre (1G)	Plastics (3H2)
Natural wood (4C1, 4C2)	Other metal (1N2)	Steel (3A2)
Other metal (4N)	Plastics (1H2)	
Plastics (4H1, 4H2)	Plywood (1D)	
Plywood (4D)	Steel (1A2)	
Reconstituted wood (4F)		
Steel (4A)		

II. SECTION II

With the exception of Part 1;2.3 (Transport of dangerous goods by post), 7;4.4 (Reporting of dangerous goods accidents and incidents);8;1.1 (Dangerous goods carried by passengers or crew) and paragraph 2 of this packing instruction, lithium metal cells and batteries packed with equipment offered for transport are not subject to other additional requirements of these Instructions if they meet the requirements of this section.

Lithium metal cells and batteries may be offered for transport provided that each cell and battery meets the provisions of 2;9.3.1 a) and e) and the following:

- 1) for a lithium metal cell, the lithium content is not more than 1 g;
- 2) for a lithium metal or lithium alloy battery, the aggregate lithium content is not more than 2 g.

II.1 General requirements

Cells and batteries must be packed in strong outer packagings that conform to Part 4;1.1.1, 1.1.3.1 and 1.1.10 (except 1.1.10.1).

<i>Contents</i>	<i>Package quantity (Section II)</i>	
	<i>Passenger</i>	<i>Cargo</i>
Net quantity of lithium metal cells or batteries per package	5 kg	5 kg

Packing Instruction 969

II.2 Additional requirements

- Lithium metal cells or batteries must:
 - be placed in inner packagings that completely enclose the cell or battery, then placed in a strong outer packaging; or
 - be placed in inner packagings that completely enclose the cell or battery, then placed with the equipment in a strong outer packaging.
- Cells and batteries must be protected so as to prevent short circuits. This includes protection against contact with conductive materials within the same packaging that could lead to a short circuit.
- The equipment must be secured against movement within the outer packaging and must be equipped with an effective means of preventing accidental activation.
- The number of cells or batteries in each package must not exceed the appropriate number for the equipment's operation, plus two spares.
- Each package of cells or batteries, or the completed package, must be capable of withstanding a 1.2 m drop test in any orientation without:
 - damage to cells or batteries contained therein;
 - shifting of the contents so as to allow battery to battery (or cell to cell) contact;
 - release of contents.
- Each package must be labelled with a lithium battery handling label (Figure 5-32).
- Each consignment must be accompanied with a document with an indication that:
 - the package contains lithium metal cells or batteries;
 - the package must be handled with care and that a flammability hazard exists if the package is damaged;
 - special procedures must be followed in the event the package is damaged, to include inspection and repacking if necessary; and
 - a telephone number for additional information.
- The words "lithium metal batteries, in compliance with Section II of PI969" must be placed on the air waybill, when an air waybill is used.
- Any person preparing or offering cells or batteries for transport must receive adequate instruction on these requirements commensurate with their responsibilities.

II.3 Outer packagings

Boxes

Drums

Jerricans

Strong outer packagings

II.4 Overpacks

When packages are placed in an overpack, the lithium battery handling label required by this packing instruction must either be clearly visible or the label must be affixed on the outside of the overpack and the overpack must be marked with the word "Overpack".

Packing Instruction 970

Passenger and cargo aircraft for UN 3091 (contained in equipment) only

1. Introduction

This entry applies to lithium metal or lithium alloy batteries contained in equipment.

Section I of this packing instruction applies to lithium metal and lithium alloy cells and batteries that are assigned to Class 9. Certain lithium metal and lithium alloy cells and batteries offered for transport and meeting the requirements of Section II of this packing instruction, subject to paragraph 2 below, are not subject to other additional requirements of these Instructions.

2. Lithium batteries forbidden from transport

The following applies to all lithium metal cells and batteries in this packing instruction:

Cells and batteries, identified by the manufacturer as being defective for safety reasons, or that have been damaged, that have the potential of producing a dangerous evolution of heat, fire or short circuit are forbidden for transport (e.g. those being returned to the manufacturer for safety reasons).

Packing Instruction 970

I. SECTION I

Each cell or battery must meet all the provisions of 2;9.3.

I.1 General requirements

Equipment must be packed in strong outer packagings that conform to Part 4;1.1.1, 1.1.3.1 and 1.1.10 (except 1.1.10.1).

UN number and proper shipping name	Package quantity (Section I)	
	Passenger	Cargo
UN 3091 Lithium metal batteries contained in equipment	5 kg of lithium metal cells or batteries	35 kg of lithium metal cells or batteries

I.2 Additional requirements

- The equipment must be secured against movement within the outer packaging and must be equipped with an effective means of preventing accidental activation.
- The equipment must be packed in strong outer packagings constructed of suitable material of adequate strength and design in relation to the packaging's capacity and its intended use unless the battery is afforded equivalent protection by the equipment in which it is contained.
- The quantity of lithium metal contained in any piece of equipment must not exceed 12 g per cell and 500 g per battery.

I.3 Outer packagings

Boxes

Drums

Jerricans

Strong outer packagings

II. SECTION II

With the exception of Part 1;2.3 (Transport of dangerous goods by post), 7;4.4 (Reporting of dangerous goods accidents and incidents), 8;1.1 (Dangerous goods carried by passengers or crew) and paragraph 2 of this packing instruction, lithium metal cells and batteries contained in equipment offered for transport are not subject to other additional requirements of these Instructions if they meet the requirements of this section.

Lithium metal cells and batteries may be offered for transport provided that each cell and battery meets the provisions of 2;9.3.1 a) and e) and the following:

- 1) for a lithium metal cell, the lithium content is not more than 1 g;
- 2) for a lithium metal or lithium alloy battery, the aggregate lithium content is not more than 2 g.

Devices such as radio frequency identification (RFID) tags, watches and temperature loggers, which are not capable of generating a dangerous evolution of heat, may be transported when intentionally active. When active, these devices must meet defined standards for electromagnetic radiation to ensure that the operation of the device does not interfere with aircraft systems. The devices must not be capable of emitting disturbing signals (such as buzzing alarms, strobe lights, etc.) during transport.

II.1 General requirements

Equipment containing batteries must be packed in strong outer packagings that conform to Part 4;1.1.1, 1.1.3.1 and 1.1.10 (except 1.1.10.1).

Contents	Package quantity (Section II)	
	Passenger	Cargo
Net quantity of lithium metal cells or batteries per package	5 kg	5 kg

II.2 Additional requirements

- The equipment must be secured against movement within the outer packaging and must be equipped with an effective means of preventing accidental activation.
- Cells and batteries must be protected so as to prevent short circuits.
- The equipment must be packed in strong outer packagings constructed of suitable material of adequate strength and design in relation to the packaging's capacity and its intended use unless the battery is afforded equivalent protection by the equipment in which it is contained.
- Each package containing more than four cells or more than two batteries installed in equipment must be labelled with a lithium battery handling label (Figure 5-32) (except button cell batteries installed in equipment (including circuit boards)).
- Each consignment with packages bearing the lithium battery handling label must be accompanied with a document with an indication that:
 - the package contains lithium metal cells or batteries;
 - the package must be handled with care and that a flammability hazard exists if the package is damaged;
 - special procedures must be followed in the event the package is damaged, to include inspection and repacking if necessary; and
 - a telephone number for additional information.
- Where a consignment includes packages bearing the lithium battery handling label, the words "lithium ion batteries, in compliance with Section II of PI970" must be placed on the air waybill, when an air waybill is used.
- Any person preparing or offering cells or batteries for transport must receive adequate instruction on these requirements commensurate with their responsibilities.

II.3 Outer packagings

Boxes

Drums

Jerricans

Strong outer packagings

II.4 Overpacks

When packages are placed in an overpack, the lithium battery handling label required by this packing instruction must either be clearly visible or the label must be affixed on the outside of the overpack and the overpack must be marked with the word "Overpack".

Packing Instruction 971

Passenger and cargo aircraft for UN 3499 only (see also Special Provision A186) and
UN 3508 (Special Provision A196) only

General requirements

Part 4;1.1.1 and 1.1.8 requirements must be met.

For the purpose of this packaging instruction, a capacitor is considered an inner packaging.

<i>UN number and proper shipping name</i>		<i>Quantity — passenger</i>	<i>Quantity — cargo</i>
UN 3499	Capacitor , electric double layer	No limit	No limit
UN 3508	Capacitor, asymmetric (with an energy storage capacity greater than 0.3 Wh)	No limit	No limit

ADDITIONAL PACKING REQUIREMENTS

For UN 3499

- Each capacitor must be transported in an uncharged state. The capacitor or, when fitted in a module, the module must be fitted with a metal strap connecting the terminals.
- Capacitors must be securely cushioned in the outer packagings.

OUTER PACKAGINGS OF COMBINATION PACKAGINGS (see 6;3.1)

Boxes

Drums

Jerricans

Strong outer packagings

Part 5
SHIPPER'S RESPONSIBILITIES

Chapter 1

GENERAL

Parts of this Chapter are affected by State Variations BE 4, BR 8, CA 1, CA 4, CA 9, CH 3, DE 1, DE 2, FR 2, FR 3, GB 1, HK 3, HR 4, IN 2, IN 3, IR 1, IR 4, IT 1, IT 2, IT 3, IT 5, JP 2, JP 8, JP 17, MY 2, MY 3, NL 3, RO 1, UA 1, US 10; see Table A-1

Note.— It is the shipper's responsibility to ensure that all of the applicable air transport requirements are met. The items indicated below are provided as examples and do not include a complete list of all the applicable requirements for air transport.

1.1 GENERAL REQUIREMENTS

Before a person offers any package or overpack of dangerous goods for transport by air, that person must ensure that:

- a) the articles or substances are not forbidden for transport by air (see Part 1, Chapter 2);
- b) the goods are properly classified, marked and labelled and otherwise in a condition for transport as required by these Instructions;
- c) the dangerous goods are packaged in compliance with all the applicable air transport requirements including:
 - inner packaging and the maximum quantity per package limits;
 - appropriate types of packaging according to the packing instructions;
 - other applicable requirements indicated in the packing instructions including:
 - single packagings may be forbidden;
 - only inner and outer packagings indicated in the packing instructions are permitted;
 - inner packaging may need to be packed in intermediate packagings; and
 - certain dangerous goods must be transported in packagings meeting a higher performance level.
 - appropriate closure procedures for inner and outer packagings (see 4;1.1.4);
 - the compatibility requirements such as those in the particular packing requirements of the packing instructions and in Part 4, Chapter 1;
 - the absorbent material requirements in the packing instructions when applicable; and
 - the pressure differential requirement in 4;1.1.6.
- d) the dangerous goods transport document has been properly executed and the declaration signed;
- e) the overpack does not contain packages of dangerous goods which require segregation according to Table 7-1;
- f) when an overpack is used, packages must be secured within the overpack;
- g) the dangerous goods are not included in any freight container/unit load device except for radioactive material as specified in 7;2.9 (subject to the approval of the operator, this does not apply to a unit load device containing consumer commodities prepared according to Packing Instruction Y963 or dry ice used as a refrigerant for other than dangerous goods when prepared according to Packing Instruction 954 or magnetized material when prepared according to Packing Instruction 953);
- h) before a package or overpack is reused, all inappropriate dangerous goods labels and markings are removed or completely obliterated;
- i) each package contained within an overpack is properly packed, marked, labelled and is free of any indication that its integrity has been compromised and in all respects is properly prepared as required in these Instructions. The "overpack" marking described in 2.4.10 is an indication of compliance with this requirement. The intended function of each package must not be impaired by the overpack; and

- ≠ j) packages and overpacks containing dangerous goods are offered to the operator separately from cargo which is not subject to these Instructions, except as provided for in 7;1.4.1.

Note 1.— Packages and overpacks containing dangerous goods may be included on the same air waybill as cargo which is not subject to these Instructions.

- ≠ *Note 2.— The requirement in 1.1 j) also applies to consolidated shipments offered to the operator.*

Note 3.— For cooling purposes, an overpack may contain dry ice, provided that the overpack meets the requirements of Packing Instruction 954.

1.2 GENERAL PROVISIONS FOR CLASS 7

1.2.1 Approval of shipments and notification

1.2.1.1 General

- ≠ In addition to the approval of package designs described in Part 6, Chapter 4, multilateral shipment approval is also required in certain circumstances (1.2.1.2 and 1.2.1.3). In some circumstances it is also necessary to notify competent authorities of a shipment (1.2.1.4).

1.2.1.2 Shipment approvals

Multilateral approval must be required for:

- a) The shipment of Type B(M) packages not conforming with the requirements of 6;7.6.5;
- b) The shipment of Type B(M) packages containing radioactive material with an activity greater than 3000 A₁ or 3000 A₂, as appropriate, or 1000 TBq, whichever is the lower;
- c) The shipment of packages containing fissile materials if the sum of the criticality safety indexes of the packages in a single freight container or in an aircraft exceeds 50; and

except that a competent authority may authorize transport into or through its country without shipment approval, by a specific provision in its design approval (see 1.2.2.1).

1.2.1.3 Shipment approval by special arrangement

Provisions may be approved by a competent authority under which a consignment, which does not satisfy all of the applicable requirements of these Instructions may be transported under special arrangement (see 1;6.4).

1.2.1.4 Notifications

Notification to competent authorities is required as follows:

- a) Before the first shipment of any package requiring competent authority approval, the shipper must ensure that copies of each applicable competent authority certificate applying to that package design have been submitted to the competent authority of the country of origin of the shipment and to the competent authority of each country through or into which the consignment is to be transported. The shipper is not required to await an acknowledgement from the competent authority, nor is the competent authority required to make such acknowledgement of receipt of the certificate;
- b) For each of the following types of shipments:
 - i) Type C packages containing radioactive material with an activity greater than 3000 A₁ or 3000 A₂, as appropriate, or 1000 TBq, whichever is the lower;
 - ii) Type B(U) packages containing radioactive material with an activity greater than 3000 A₁ or 3000 A₂, as appropriate, or 1000 TBq, whichever is the lower;
 - iii) Type B(M) packages;
 - iv) Shipment under special arrangement;

the shipper must notify the competent authority of the country of origin of the shipment and the competent authority of each country through or into which the consignment is to be transported. This notification must be in the hands of each competent authority prior to the commencement of the shipment, and preferably at least 7 days in advance;

- ≠ c) The shipper is not required to send a separate notification if the required information has been included in the application for approval of shipment (see 6;7.22);
- d) The consignment notification must include:
 - i) sufficient information to enable the identification of the package or packages including all applicable certificate numbers and identification marks;
 - ii) information on the date of shipment, the expected date of arrival and proposed routing;
 - iii) the names of the radioactive material or nuclides;
 - iv) descriptions of the physical and chemical forms of the radioactive material, or whether it is special form radioactive material or low dispersible radioactive material; and
 - v) the maximum activity of the radioactive contents during transport expressed in units of becquerels (Bq) with an appropriate SI prefix symbol (see 1;3.2). For fissile material, the mass of fissile material (or of each fissile nuclide for mixtures when appropriate) in units of grams (g), or multiples thereof, may be used in place of activity.

1.2.2 Certificates issued by the competent authority

1.2.2.1 Certificates issued by the competent authority are required for the following:

- a) Designs for:
 - i) special form radioactive material;
 - ii) low dispersible radioactive material;
 - + iii) fissile material excepted under 2;7.2.3.5.1 f);
 - ≠ iv) packages containing 0.1 kg or more of uranium hexafluoride;
 - ≠ v) packages containing fissile material unless excepted by 2;7.2.3.5, 6;7.10.2 or 6;7.10.3;
 - ≠ vi) Type B(U) packages and Type B(M) packages;
 - ≠ vii) Type C packages;
- b) Special arrangements;
- c) Certain shipments (1.2.1.2).
- + d) Determination of the basic radionuclide values referred to in 2;7.2.2.1 for individual radionuclides which are not listed in Table 2-12 (see 2;7.2.2.2 a));
- + e) Alternative activity limits for an exempt consignment of instruments or articles (see 2;7.2.2.2 b));

The certificates must confirm that the applicable requirements are met, and for design approvals, must attribute to the design an identification mark.

- ≠ The certificates of approval for the package design and shipment may be combined into a single certificate.

Certificates and applications for these certificates must be in accordance with the requirements in 6;7.22.

1.2.2.2 The shipper must be in possession of a copy of each applicable certificate.

- ≠ 1.2.2.3 For package designs where it is not required that a competent authority issue a certificate of approval, the shipper must, on request, make available for inspection by the relevant competent authority, documentary evidence of the compliance of the package design with all the applicable requirements.

1.2.3 Determination of transport index (TI) and criticality safety index (CSI)

1.2.3.1 Determination of transport index

1.2.3.1.1 The transport index (TI) for a package, overpack or freight container, must be the number derived in accordance with the following procedure:

- a) Determine the maximum radiation level in units of millisieverts per hour (mSv/h) at a distance of 1 m from the external surfaces of the package, overpack, or freight container. The value determined must be multiplied by 100 and the resulting number is the transport index. For uranium and thorium ores and their concentrates, the maximum radiation level at any point 1 m from the external surface of the load may be taken as:

- 0.4 mSv/h for ores and physical concentrates of uranium and thorium;
 0.3 mSv/h for chemical concentrates of thorium;
 0.02 mSv/h for chemical concentrates of uranium, other than uranium hexafluoride;

- b) For freight containers, the value determined in step a) above must be multiplied by the appropriate factor from Table 5-1;
 c) The value obtained in steps a) and b) above must be rounded up to the first decimal place (e.g. 1.13 becomes 1.2), except that a value of 0.05 or less may be considered as zero.

1.2.3.1.2 The transport index for each overpack or freight container must be determined as either the sum of the transport indices of all the packages contained, or by direct measurement of radiation level, except in the case of non-rigid overpacks for which the transport index must be determined only as the sum of the transport indices of all the packages.

Table 5-1. Multiplication factors for freight containers

Size of load*	Multiplication factor
size of load $\leq 1 \text{ m}^2$	1
$1 \text{ m}^2 < \text{size of load} \leq 5 \text{ m}^2$	2
$5 \text{ m}^2 < \text{size of load} \leq 20 \text{ m}^2$	3
$20 \text{ m}^2 < \text{size of load}$	10
* Largest cross-sectional area of the load being measured.	

1.2.3.1.3 The criticality safety index for each overpack or freight container must be determined as the sum of the CSIs of all the packages contained. The same procedure must be followed for determining the total sum of CSIs in a consignment or aboard an aircraft.

≠ 1.2.3.1.4 Packages, overpacks and freight containers must be assigned to either category I-WHITE, II-YELLOW or III-YELLOW in accordance with the conditions specified in Table 5-2 and with the following requirements:

- ≠ a) for a package, overpack or freight container, both the transport index and the surface radiation level conditions must be taken into account in determining which is the appropriate category. Where the transport index satisfies the condition for one category but the surface radiation level satisfies the condition for a different category, the package, overpack or freight container must be assigned to the higher category. For this purpose, category I-WHITE must be regarded as the lowest category;
- b) the transport index must be determined following the procedures specified in 1.2.3.1.1 and 1.2.3.1.2;
- c) if the surface radiation level is greater than 2 mSv/h, the package or overpack must be transported under exclusive use and under the provisions of 7;2.10.5.3, as appropriate;
- d) a package transported under a special arrangement must be assigned to category III-YELLOW except under the provisions of 1.2.3.1.5;
- ≠ e) an overpack or freight container which contains packages transported under special arrangement must be assigned to category III-YELLOW except under the provisions of 1.2.3.1.5.

≠ **Table 5-2. Categories of packages, overpacks and freight containers**

<i>Conditions</i>		
<i>Transport index</i>	<i>Maximum radiation level at any point on external surface</i>	<i>Category</i>
0*	Not more than 0.005 mSv/h	I-WHITE
More than 0 but not more than 1*	More than 0.005 mSv/h but not more than 0.5 mSv/h	II-YELLOW
More than 1 but not more than 10	More than 0.5 mSv/h but not more than 2 mSv/h	III-YELLOW
More than 10	More than 2 mSv/h but not more than 10 mSv/h	III-YELLOW**
* If the measured transport index is not greater than 0.05, the value quoted may be zero in accordance with 1.2.3.1.1 c). ** Must be transported under exclusive use and special arrangement except for freight containers (see Table 7-6).		

≠ 1.2.3.1.5 In all cases of international transport of packages requiring competent authority approval of design or shipment, for which different approval types apply in the different countries concerned by the shipment, the categorization must be in accordance with the certificate of the country of origin of design.

≠ **1.2.4 Specific provisions for excepted packages of radioactive material of Class 7**

≠ 1.2.4.1 Excepted packages of radioactive material of Class 7 must be legibly and durably marked on the outside of the packaging with:

- a) the UN number preceded by the letters "UN";
- b) an identification of either the shipper or consignee, or both; and
- c) the permissible gross mass if this exceeds 50 kg.

≠ 1.2.4.2 The documentation requirements of 5;4 do not apply to excepted packages of radioactive material of Class 7, except that:

- ≠ a) the UN number preceded by the letters "UN" and the name and address of the shipper and the consignee and, if relevant, the identification mark for each competent authority certificate of approval (see 5;4.1.5.7.1 g)) must be shown on a transport document such as an air waybill or other similar document complying with the requirements of 5;4.1.2.1 to 5;4.1.2.4;
- ≠ b) the requirements, if relevant, of 4.1.5.7.1 g), 4.1.5.7.3 and 4.1.5.7.4 apply; and
- + c) the requirements of 4.4 apply.

Where an agreement exists with the operator, the shipper may provide the information by EDP or EDI techniques.

+ 1.2.4.3 The requirements of 2.4.5.2 and 3.5.1.1 k) apply if relevant.

1.3 INFORMATION TO EMPLOYEES

A shipper must provide such information to employees as will enable them to carry out their responsibilities with regard to the transport of dangerous goods by air.

1.4 TRAINING

Before a consignment of dangerous goods is offered for air transport, all relevant persons involved in its preparation must have received training to enable them to carry out their responsibilities, as detailed in Part 1. Where a shipper does not have trained staff, the "relevant persons" may be interpreted as applying to those employed to act on the shipper's behalf and to undertake the shipper's responsibilities in the preparation of the consignment. However, such persons must be trained as required by Part 1, Chapter 4.

1.5 SALVAGE PACKAGINGS

Before a person offers any salvage packaging for transport by air, that person must ensure that:

- it is marked with the proper shipping name and UN number of, and bear all the labels appropriate for, the dangerous goods contained therein;
- ≠ — it is marked with the word “Salvage” and the lettering of the “Salvage” marking must be at least 12 mm high;
- the words “Salvage package” are added after the description of the goods in the dangerous goods transport document required by 4.1; and
- where the package contains dangerous goods restricted to transport on cargo aircraft only, it bears a “Cargo aircraft only” label and the dangerous goods transport document contains the necessary statement according to 4.1.5.7.1 b).

In addition, that person must ensure that all other applicable requirements are met.

- + *Note.— The size requirement for the “Salvage” marking applies as from 1 January 2016.*

1.6 EMPTY PACKAGINGS

1.6.1 Other than for Class 7, a packaging which previously contained dangerous goods must be identified, marked, labelled and placarded as required for those dangerous goods unless steps such as cleaning, purging of vapours or refilling with a non-dangerous substance are taken to nullify any hazard.

1.6.2 Before an empty packaging which had previously contained an infectious substance is returned to the shipper, or sent elsewhere, it must be disinfected or sterilized to nullify any hazard, and any label or marking indicating that it had contained an infectious substance must be removed or obliterated.

- ≠ 1.6.3 Freight containers as well as other packagings and overpacks used for the transport of radioactive material must not be used for the storage or transport of other goods unless decontaminated below the level of 0.4 Bq/cm² for beta and gamma emitters and low toxicity alpha emitters and 0.04 Bq/cm² for all other alpha emitters.

1.7 MIXED PACKING

When two or more dangerous goods are packed within the same outer packaging, the package must be labelled and marked as required for each substance. Labels need not be applied for a subsidiary risk if the hazard is already represented by a primary risk label.

Chapter 2

PACKAGE MARKINGS

Parts of this Chapter are affected by State Variations BR 6, CA 4, DQ 4, ES 1, HK 2, IR 4, MY 6, PK 1, RU 1, US 1, US 7, VC 5, VU 1; see Table A-1

2.1 THE REQUIREMENT TO MARK

Unless otherwise provided in these Instructions, packages of dangerous goods and overpacks containing dangerous goods offered for transport by air must be marked as required by this Chapter.

2.2 APPLICATION OF MARKINGS

2.2.1 All markings must be so placed on the packagings that they are not covered or obscured by any part of or attachment to the packaging or any other label or marking.

2.2.2 All package markings required by 2.1:

- a) must be durable and printed or otherwise marked on, or affixed to, the external surface of the package;
- b) must be readily visible and legible;
- c) must be able to withstand open weather exposure without a substantial reduction in effectiveness;
- d) must be displayed on a background of contrasting colour; and
- e) must not be located with other package markings that could substantially reduce their effectiveness.

2.3 PROHIBITED MARKING

Arrows for purposes other than indicating proper package orientation must not be displayed on a package containing liquid dangerous goods.

2.4 MARKING SPECIFICATIONS AND REQUIREMENTS

2.4.1 Marking with proper shipping name and UN or ID number

≠ 2.4.1.1 Unless otherwise provided in these Instructions, the proper shipping name of the dangerous goods (supplemented with the technical name(s) if appropriate, see Part 3, Chapter 1) and, when assigned, the corresponding UN number preceded by the letters "UN" or "ID", as appropriate, must be displayed on each package. The UN number and the letters "UN" or "ID" must be at least 12 mm high, except for packagings of 30 litres capacity or less or of 30 kg maximum net mass and for cylinders of 60 litres water capacity, when they must be at least 6 mm in height and except for packagings of 5 litres or 5 kg or less when they must be of an appropriate size. In the case of unpackaged articles, the marking must be displayed on the article, on its cradle or on its handling, storage or launching device. A typical package marking would be:

> "Corrosive liquid, acidic, organic, n.o.s. (caprylyl chloride) UN 3265".

2.4.1.2 For solid substances, unless the word "molten" is already included in the proper shipping name, it must be added to the proper shipping name on the package when a substance is offered for air transport in the molten state (see Part 3, Chapter 1).

Note.— Additional descriptive text in the entries in column 1 of the Dangerous Goods List (Table 3-1) are not part of the proper shipping name but may be used in addition to the proper shipping name.

2.4.2 Shipper and consignee identification

The name and address of the person who offers the dangerous goods for transport by air and of the consignee must be provided on each package and should be located on the same surface of the package near the proper shipping name marking, if the package dimensions are adequate.

2.4.3 Special marking requirements for explosives

The proper shipping name required by 2.4.1 may be supplemented by additional descriptive text to indicate commercial or military names.

2.4.4 Packaging specification markings

2.4.4.1 Each outer or single packaging used for dangerous goods, for which specification packaging is required in Part 4, must bear the markings appropriate to the contents as specified in Part 6, Chapter 2.

2.4.4.2 Markings must be stamped, printed or otherwise marked on the package to provide adequate permanency.

2.4.5 Special marking requirements for radioactive material

- ≠ 2.4.5.1 The marking of excepted packages of radioactive material of Class 7 must be as required by 1.2.4.1.
- ≠ 2.4.5.2 Each package of gross mass exceeding 50 kg must have its permissible gross mass legibly and durably marked on the outside of the packaging.
- ≠ 2.4.5.3 Each package which conforms to:
 - a) a Type IP-1 package, a Type IP-2 package or a Type IP-3 package design must be legibly and durably marked on the outside of the packaging with "TYPE IP-1", "TYPE IP-2" or "TYPE IP-3" as appropriate;
 - b) a Type A package design must be legibly and durably marked on the outside of the packaging with "TYPE A";
 - c) a Type IP-2 package, a Type IP-3 package or a Type A package design must be legibly and durably marked on the outside of the packaging with the international vehicle registration code (VRI Code) of the country of origin of design and either the name of the manufacturer, or other identification of the packaging specified by the competent authority of the country of origin of design.
- ≠ 2.4.5.4 Each package which conforms to a design approved under one or more of 1.2.2.1, 6;7.21.1 to 6;7.21.4, 6;7.24.2.1 and 6.4.23.4 to 6.4.23.7 of the UN Model Regulations must be legibly and durably marked on the outside of the package with the following information:
 - a) the identification mark allocated to that design by the competent authority;
 - b) a serial number to uniquely identify each packaging which conforms to that design; and
 - c) "Type B(U)", "Type B(M)" or "Type C" in the case of a Type B(U), Type B(M) or Type C package design.
- + *Note.— Empty Type B(U) or Type B(M) packages, as specified in the Note to 2;7.2.4.1.1.7, shipped as industrial packages Type IP-1 must bear the appropriate specification marking for a Type IP-1 in which case the appropriate specification markings specified in 2.4.5.4 must be obliterated.*
- ≠ 2.4.5.5 Each package which conforms to a Type B(U), Type B(M) or Type C package design must have the outside of the outermost receptacle which is resistant to the effects of fire and water plainly marked by embossing, stamping or other means resistant to the effects of fire and water with the trefoil symbol, as shown in Figure 5-1 below.
- ≠ 2.4.5.6 In all cases of international transport of packages requiring competent authority approval of design or shipment, for which different approval types apply in the different countries concerned by the shipment, the marking must be in accordance with the certificate of the country of origin of the design.

2.4.6 Special marking requirements for refrigerated liquefied gas

The upright position of each package must be indicated prominently by either the "Package orientation" label (Figure 5-26) or pre-printed package orientation labels meeting the same specification as either Figure 5-26 or ISO Standard 780:1997. The label must be affixed to or printed on at least two opposite vertical sides of the package with the arrows pointing in the correct direction. The wording "KEEP UPRIGHT" must be placed at 120° intervals around the package or on each side. Packages must also be clearly marked "DO NOT DROP — HANDLE WITH CARE".

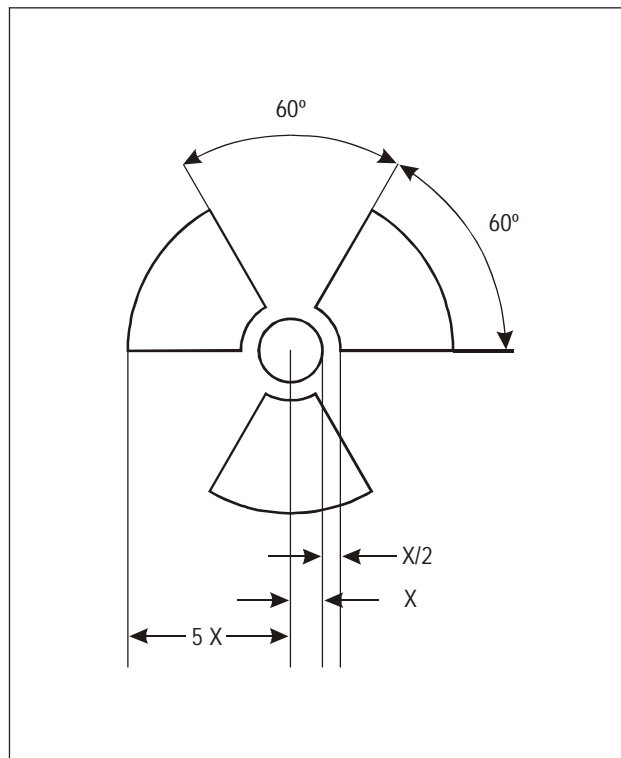

Figure 5-1. Basic trefoil symbol with proportions based on a central circle of radius X. The minimum allowable size of X must be 4 mm.

2.4.7 Special marking requirement for dry ice

The net mass of solid carbon dioxide (dry ice) must be marked on any package containing such substance.

2.4.8 Special marking requirement for biological substances, Category B

Packages containing biological substances, Category B packed in accordance with Packing Instruction 650 must be marked "Biological substance, Category B".

2.4.9 Special marking provisions for environmentally hazardous substances

≠ 2.4.9.1 Unless otherwise specified in these Instructions, packages containing environmentally hazardous substances meeting the criteria of 2.9.2.1 a) (UN Nos. 3077 and 3082) must be durably marked with the environmentally hazardous substance mark and the packages must also bear a Class 9 hazard label.

2.4.9.2 The environmentally hazardous substance mark must be located adjacent to the markings required by 2.4.1.1. The requirements of 2.2.2 must be met.

≠ 2.4.9.3 The environmentally hazardous substance mark must be as shown in Figure 5-2. The marking must be in the form of a square set at an angle of 45° (diamond-shaped). The symbol (fish and tree) must be black on white or suitable contrasting background. The minimum dimensions must be 100 mm × 100 mm and the minimum width of line forming the diamond must be 2 mm. If the size of the package so requires, the dimensions/line thickness may be reduced, provided the marking remains clearly visible. Where dimensions are not specified, all features must be in approximate proportion to those shown.

Note.— The labelling provisions of 5.3 apply in addition to any requirement for packages to bear the environmentally hazardous substance mark.

>

≠



Figure 5-2. Symbol (fish and tree): black on white or suitable contrasting background

2.4.10 Marking of overpacks

≠ An overpack must be marked with the word “Overpack”, with the proper shipping name, UN number, and special handling instructions appearing on interior packages for each item of dangerous goods contained in the overpack unless markings and labels representative of all dangerous goods in the overpack are visible, except as required in 3.2.6 and 3.5.1.1 h) to i). Packaging specification markings must not be reproduced on the overpack. When packages containing dangerous goods in limited quantities are placed in an overpack, the overpack must also be marked with the limited quantity marking shown in Figure 3-1 unless the markings representative of all dangerous goods in the overpack are visible. The lettering of the “Overpack” marking must be at least 12 mm high.

+ *Note.— The size requirement for the “Overpack” marking applies as from 1 January 2016.*

2.4.11 Additional markings of packages containing dangerous goods in limited quantities

Provisions for the marking of packages containing dangerous goods in limited quantities are contained in 3;4.

2.4.12 Specific provisions for dangerous goods packed in excepted quantities

Provisions for the marking of packages containing dangerous goods in excepted quantities are contained in 3;5.

2.4.13 Markings required by other modes of transport

Markings required by other international or national transport regulations are permitted in addition to markings required by these Instructions, provided that they cannot be confused with or conflict with any markings prescribed by these Instructions, because of their colour, design or shape.

2.4.14 Special marking requirement for chemical oxygen generators

When chemical oxygen generators contained in protective breathing equipment (PBE) are being transported under Special Provision A144, the statement “Aircrew protective breathing equipment (smoke hood) in accordance with Special Provision A144” shall be marked adjacent to the proper shipping name on the package.

2.4.15 Marking requirements for IBCs used to transport UN 3077

Intermediate bulk containers must comply with the marking requirements applicable to other packagings, except that intermediate bulk containers of more than 450 L capacity must be marked with the proper shipping name and UN number, as required in 2.4.1, and the environmentally hazardous substance mark, on two opposite sides.

2.5 LANGUAGES TO BE USED

In addition to the languages which may be required by the State of Origin, English should be used.

Chapter 3

LABELLING

*Parts of this Chapter are affected by State Variations AU 5, CA 1, CA 4
JP 9, PK 2, VC 6, VU 5; see Table A-1*

Note 1.— These provisions relate essentially to danger labels. However, additional marking or symbols indicating precautions to be taken in handling or storing a package (e.g. a symbol representing an umbrella indicating that a package should be kept dry) may be displayed on a package as appropriate. For such purposes, it is preferable to use the symbols recommended by the International Organization for Standardization (ISO).

Note 2.— In 3.6 of this Chapter there are provisions concerning the placarding of large freight containers for radioactive material.

Note 3.— The provisions concerning the placarding of portable tanks are shown in the Supplement, Part S-4;12.4.

3.1 THE REQUIREMENT TO LABEL

3.1.1 Where articles or substances are specifically listed in the Dangerous Goods List (Table 3-1), a danger class label must be affixed for the hazard shown in column 3 of Table 3-1. A subsidiary risk label must also be affixed for any risk indicated by a class or division number in column 4 of Table 3-1. However, special provisions indicated in column 7 may also require a subsidiary risk label where no subsidiary risk is indicated in column 4 or may exempt from the requirement for a subsidiary risk label where such a risk is indicated in the Dangerous Goods List.

3.1.2 Labels identifying the primary and subsidiary risks of the dangerous goods must bear the class or division number as required in 3.5.1.

3.1.3 All labels must be able to withstand open weather exposure without a substantial reduction in effectiveness.

3.2 APPLICATION OF LABELS

3.2.1 The labels required to be displayed on packages of dangerous goods are identified in the Dangerous Goods List for articles and substances specifically listed by name and for articles and substances not specifically listed by name which are covered by generic or n.o.s. entries.

3.2.2 Packages containing substances of Class 8 need not show a subsidiary risk label for Division 6.1 if the toxicity arises solely from the destructive effect on tissue. Substances of Division 4.2 need not show a subsidiary risk label for Division 4.1 if the substance is also a flammable solid.

3.2.3 Packages containing organic peroxides which meet the criteria for Class 8, Packing Group I or II must be labelled with a corrosive subsidiary risk label.

Note.— Many liquid organic peroxide formulations are flammable; however, no subsidiary risk flammable label is required because the organic peroxide label itself is considered to imply that the product may be flammable.

3.2.4 In addition to the primary hazard label (Figure 5-17), infectious substances packages must bear any other label required by the nature of the contents. This is not required if a quantity of 30 ml or less of dangerous goods included in classes 3, 8 or 9 is packed in each primary receptacle containing infectious substances provided these substances meet the requirements of 3;5.1.2.

3.2.5 Packages containing radioactive material having additional hazardous characteristics must also be labelled to indicate those characteristics.

≠ 3.2.6 Except when enlarged labels are used in accordance with 3.6, each package, overpack and freight container containing radioactive material must bear the labels conforming to Figures 5-19, 5-20 and 5-21 according to the appropriate category. Labels must be affixed to two opposite sides on the outside of the package or overpack or on the outside of all four sides of a freight container. Each overpack containing radioactive material must bear at least two labels on opposite sides of the outside of the overpack. In addition, each package, overpack and freight container containing fissile material, other than

fissile material excepted under the provisions of 2;7.2.3.5 must bear labels conforming to the model shown in Figure 5-22; such labels, where applicable, must be affixed adjacent to the labels conforming to Figure 5-19, 5-20, or 5-21, as applicable. Labels must not cover the markings specified in Chapter 2. Any labels which do not relate to the contents must be removed or covered.

3.2.7 Intermediate bulk containers must comply with the labelling requirements applicable to other packagings, except that intermediate bulk containers of more than 450 L capacity must be labelled on two opposite sides.

≠ 3.2.8 Except as provided in 3.5.1.1 d), each class hazard label must:

- a) be affixed to a background of contrasting colour or must have a dotted or solid line outer boundary;
- b) be located on the same surface of the package near the proper shipping name marking, if the package dimensions are adequate;
- c) be so placed on the packaging that they are not covered or obscured by any part of or attachment to the packaging or any other label or marking;
- d) when primary and subsidiary risk labels are required, be displayed next to each other; and

≠ e) be affixed at an angle of 45° (diamond shaped), unless the package dimensions are inadequate.

3.2.9 Labels must not be folded. Cylindrical packages must be of such dimensions that a label will not overlap itself. In the case of cylindrical packages containing radioactive materials, which require two identical labels, these labels must be centred on opposite points of the circumference and must not overlap each other. If the dimensions of the package are such that two identical labels cannot be affixed without overlapping each other, one label is acceptable provided it does not overlap itself.

3.2.10 Labels must be firmly affixed to or printed on the package of dangerous goods. Where a package is of such an irregular shape that a label cannot be affixed to or printed on a surface, it is acceptable to attach the label to the package by an adequately strong tag.

3.2.11 Since packages or consignments of magnetized material (Class 9) must bear the "Magnetized material" label (Figure 5-24) as required by column 5 of Table 3-1, such packages or consignments do not need to bear the "Miscellaneous dangerous goods" label (Figure 5-23).

3.2.12 In addition to the class hazard labels specified in 3.1, handling labels must also be affixed to packages of dangerous goods as follows:

a) the "Cargo aircraft only" label (Figure 5-25) must be affixed:

- 1) when the package containing the dangerous goods may only be transported on a cargo aircraft. However, where the packing instruction number and the permitted quantity per package are identical for passenger and cargo aircraft, the "Cargo aircraft only" label should not be used;
- 2) to each Type B(M) package of radioactive material and any freight container containing such a Type B(M) package;
- 3) on the same surface of the package near the hazard labels;

b) when required by the provisions of 4;1.1.13, either the "Package orientation" label (Figure 5-26), or preprinted package orientation labels meeting the same specification as either Figure 5-26 or ISO Standard 780:1997, must be affixed to or printed on at least two opposite vertical sides of the package with the arrows pointing in the correct direction. The words "Dangerous goods" may be inserted on the label below the line;

c) for packages containing refrigerated liquefied gases, the "Cryogenic liquid" label (Figure 5-28) must be affixed on all packages;

d) for packages containing self-reactive substances of Division 4.1 or Division 5.2 organic peroxides, the "Keep away from heat" label (Figure 5-29) must be affixed on all packages. This label should be affixed on the same surface of the package near the hazard label(s);

e) for excepted packages of radioactive material the "Radioactive material, excepted package" handling label (Figure 5-30) must be affixed;

+ f) be affixed to a background of contrasting colour or must have a dashed or solid line outer boundary;

+ g) be so placed on the packaging that they are not covered or obscured by any part of or attachment to the packaging or any other label or marking.

3.2.13 Where a text is indicated in Figures 5-1 to 5-31, an equivalent text in another language may be used.

3.2.14 Labels required by other international or national transport regulations are permitted in addition to labels required by these Instructions, provided that they cannot be confused with or conflict with any label prescribed by these Instructions, because of their colour, design or shape.

3.3 LABELLING OF OVERPACKS

3.3.1 An overpack must be labelled as required for packages by Chapter 3, for each item of dangerous goods contained in the overpack unless labels representative of all dangerous goods in the overpack are visible.

3.3.2 An overpack containing single packages with end closures containing liquid dangerous goods must be labelled with either the "Package Orientation" label (Figure 5-26), or pre-printed package orientation labels meeting the same specification as either Figure 5-26 or ISO Standard 780:1997, unless such labels are affixed to the package and are visible from the outside of the overpack. Such labels must be affixed to or printed on at least two opposite vertical sides of the overpack with the arrows pointing in the direction required to indicate the orientation of the overpack required to ensure that end closures are upward, notwithstanding that such single packages may also have side closures.

3.4 PROHIBITED LABELLING

Arrows for purposes other than indicating proper package orientation must not be displayed on a package containing liquid dangerous goods.

3.5 LABEL SPECIFICATIONS

3.5.1 Class hazard label specifications

≠ 3.5.1.1 Labels must satisfy the provisions of this section and conform, in terms of colour, symbols and general format, to the specimen labels shown in Figures 5-3 to 5-24.

+ Note.— Where appropriate, labels in Figures 5-3 to 5-24 are shown with a dotted outer boundary as provided for in 3.5.1.1 a). This is not required when the label is applied on a background of contrasting colour.

Class hazard labels must conform to the following specifications:

≠ a) Labels must be configured as described below (see Figure 5-3).

i) Labels must be displayed on a background of contrasting colour, or must have either a dotted or solid outer boundary line.

ii) The label must be in the form of a square set at an angle of 45° (diamond shaped). The minimum dimensions must be 100 mm × 100 mm and the minimum width of the line inside the edge forming the diamond must be 2 mm. The line inside the edge must be parallel and 5 mm from the outside of that line to the edge of the label. The line inside the edge on the upper half of the label must be the same colour as the symbol, and the line inside the edge on the lower half of the label must be the same colour as the class or division number in the bottom corner. Where dimensions are not specified, all features must be in approximate proportion to those shown.

iii) Labels of 50 mm × 50 mm may be used on packages containing infectious substances where the packages are of dimensions such that they can only bear smaller labels. The line inside the edge must remain 5 mm to the edge of the label. The minimum width of the line inside the edge must remain 2 mm. Dimensions for labels on cylinders must comply with 3.5.1.1 b).

+ Note.— The provisions of 3.5.1.1 a) from the 2013-2014 Edition of these Instructions may continue to be applied until 31 December 2016. When so applied, 3.5.1.1 a) i), ii) and iii) need not apply until 1 January 2017.

≠ b) Cylinders for Class 2 may, on account of their shape, orientation and securing mechanisms for transport, bear labels representative of those specified in this chapter, which have been reduced in size, according to ISO 7225:2005, for display on the non-cylindrical part (shoulder) of such cylinders. Labels may overlap to the extent provided for by ISO 7225:2005 "Gas cylinders — Precautionary labels"; however, in all cases the labels representing the primary hazard and the numbers appearing on any label must remain fully visible and the symbols recognizable.

- ≠ c) With the exception of labels for Divisions 1.4, 1.5 and 1.6 of Class 1, the upper half of the label must contain the pictorial symbol and the lower half must contain the class or, in the case of labels for Class 5, the division number, as appropriate. The label may include such text as the UN number, or words describing the hazard class (e.g. "flammable") in accordance with 3.5.1.1 e) provided that the text does not obscure or detract from the other required label elements.
- ≠ d) In addition, except for Divisions 1.4, 1.5 and 1.6, labels for Class 1 must show in the lower half, above the class number, the division number and compatibility group letter for the substance or article. Labels for Divisions 1.4, 1.5 and 1.6 must show in the upper half the division number and in the lower half the class number and the compatibility group letter.
- ≠ e) Unless otherwise provided for in these Instructions, only text indicating the nature of the risk may be inserted in the lower half of the label (in addition to the class or division number or compatibility group).
- ≠ f) The symbols, texts and numbers must be shown in black on all labels except:
 - 1) the Class 8 label, where the text (if any) and class number must appear in white;
 - 2) labels with entirely green, red or blue backgrounds, where they may be shown in white;
 - 3) the Division 5.2 label, where the symbol may be shown in white; and
 - 4) the Division 2.1 label displayed on cylinders and gas cartridges for liquefied petroleum gases, where they may be shown in the background colour of the receptacle if adequate contrast is provided.
- g) A label may contain form identification information, including the name of its maker, provided that information is printed outside of the solid line border in no larger than 10-point type.

Labelling of radioactive material

- ≠ h) Each label conforming to the applicable Figure 5-19, 5-20 or 5-21 must be completed with the following information:
 - 1) Contents:
 - A) except for LSA-I material, the name(s) of the radionuclide(s) as taken from Table 2-12, using the symbols prescribed therein. For mixtures of radionuclides, the most restrictive nuclides must be listed to the extent the space on the line permits. The group of LSA or SCO must be shown following the name(s) of the radionuclide(s). The terms "LSA-II", "LSA-III", "SCO-I" and "SCO-II" must be used for this purpose;
 - B) for LSA-I material, the term "LSA-I" is all that is necessary; the name of the radionuclide is not necessary;
 - 2) Activity: The maximum activity of the radioactive contents during transport expressed in units of becquerels (Bq) with the appropriate SI prefix symbol. For fissile material, the total mass of fissile nuclides in units of grams (g), or multiples thereof, may be used in place of activity;
 - 3) For overpacks and freight containers the "contents" and "activity" entries on the label must bear the information required in 3.5.1.1 h) 1) A) and B), respectively, totalled together for the entire contents of the overpack or freight container except that on labels for overpacks or freight containers containing mixed loads of packages containing different radionuclides, such entries may read "See Transport Documents";
 - 4) Transport index: The number determined in accordance with 1.2.3.1.1 and 1.2.3.1.2. (No transport index entry is required for category I-WHITE.)
- ≠ i) Each label conforming to Figure 5-22 must be completed with the criticality safety index (CSI) as stated in the certificate of approval applicable in the States through or into which the consignment is transported and issued by the competent authority.
- ≠ j) For overpacks and freight containers, the label conforming to Figure 5-22 must bear the sum of the criticality safety indexes of all the packages contained therein.
- ≠ k) In all cases of international transport of packages requiring competent authority approval of design or shipment, for which different approval types apply in the different countries concerned by the shipment, the labelling must be in accordance with the certificate of the country of origin of design.
- ≠ 3.5.1.2 Illustrations of the class hazard labels, showing the approved symbols and colours, are given in Figures 5-4 to 5-24. The label descriptions used in column 5 of Table 3-1 are indicated in parentheses.
- ≠ *Note 1.— The asterisk appearing in the bottom corner of the label indicates the location of the class or division number when the label is used to show the primary risk. See Figures 5-4 to 5-7 concerning the location of information on explosives labels.*

Note 2.— Minor variations in the design of the symbol on labels or other differences such as the width of vertical lines on labels as shown in these Instructions or in regulations of other modes, which do not affect the obvious meaning of the label, are acceptable. For example the hand shown on the Class 8 label may be shown with or without shading, the extreme right and left vertical lines on the Division 4.1 and Class 9 label may extend to the edge of the label or there may be some white space at the edge, etc.

3.5.2 Handling labels

3.5.2.1 Handling label specifications

≠ An illustration of each of the handling labels showing the approved design and colour is given in Figures 5-25 to 5-27 and Figures 5-29 to 5-32. The minimum label dimensions are shown in the figures. Where dimensions or features are not specified, these must be in approximate proportion to those shown; however:

a) labels having dimensions not smaller than half of those indicated may be used on packages containing infectious substances when the packages are of dimensions such that they can only bear smaller labels; and

≠ b) orientation labels may meet the specification of either Figure 5-27 or ISO Standard 780:1997.

3.5.2.2 Lithium battery handling label

≠ Packages containing lithium batteries that meet the requirements of Section II of Packing Instructions 965 to 970 must bear a "Lithium battery" handling label shown in Figure 5-32, as required by the applicable packing instruction. The label must be a minimum dimension of 120 mm wide × 110 mm high except labels of 105 mm wide × 74 mm high may be used on packages containing lithium batteries where the packages are of dimensions such that they can only bear smaller labels. When the reduced size label is used, the label features must be in approximate proportion to those shown on the full-size label (Figure 5-32). The label must show "Lithium metal batteries" or "Lithium ion batteries", as applicable, and a telephone number for additional information. Where the package contains both types of batteries, the label must show "Lithium metal and lithium ion batteries". Packages containing lithium batteries that meet the requirements of Section IB of Packing Instructions 965 and 968 must bear both a "Lithium battery" handling label shown in Figure 5-32 and a Class 9 hazard label (Figure 5-24).

3.6 PLACARDING OF LARGE FREIGHT CONTAINERS CONTAINING RADIOACTIVE MATERIAL

3.6.1 Special provisions for Class 7

3.6.1.1 Large freight containers carrying packages (other than excepted packages) and tanks must bear four placards which conform with Figure 5-27. The placards must be affixed in a vertical orientation to each side wall and each end wall of the large freight container. Any placards which do not relate to the contents must be removed. Instead of using both labels and placards, it is permitted as an alternative to use enlarged labels only, as shown in Figures 5-18, 5-19 and 5-20, and where appropriate Figure 5-21, with dimensions as required for the placard in Figure 5-27.

3.6.1.2 For Class 7, the placard must have minimum overall dimensions of 250 mm by 250 mm with a black line running 5 mm inside the edge and parallel with it, and must be otherwise as shown in Figure 5-27. The number 7 must not be less than 25 mm high. The background colour of the upper half of the placard must be yellow and of the lower half white, the colour of the trefoil and the printing must be black. The use of the word "Radioactive" in the bottom half is optional to allow the use of this placard to display the appropriate United Nations number for the consignment.

+

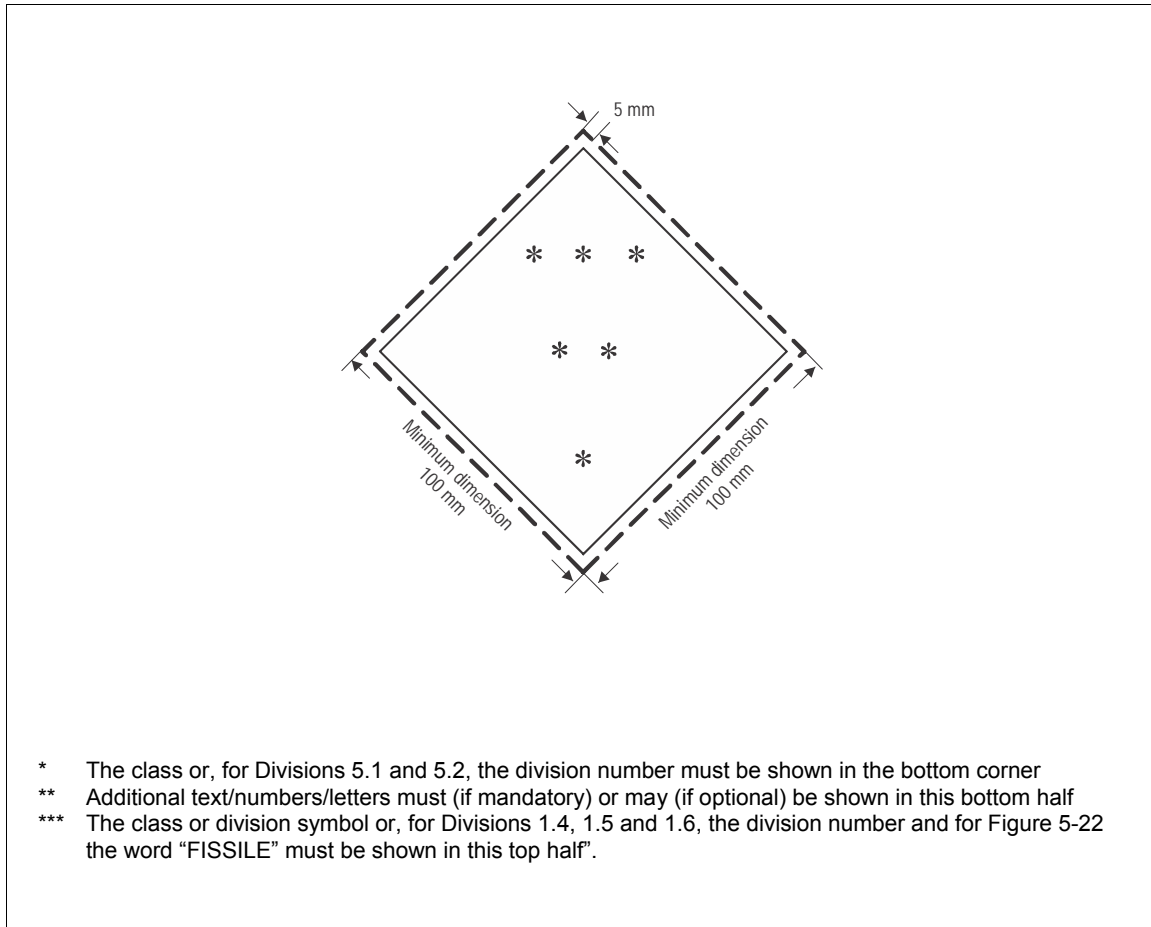

Figure 5-3. Class/division label

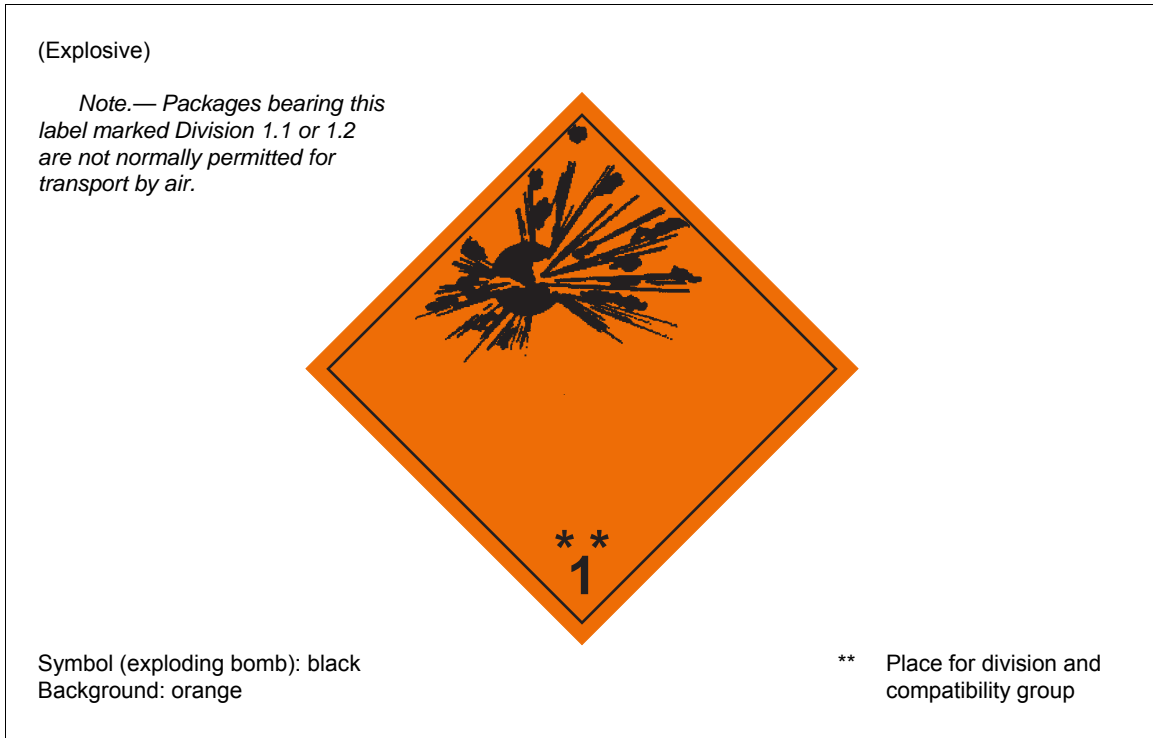
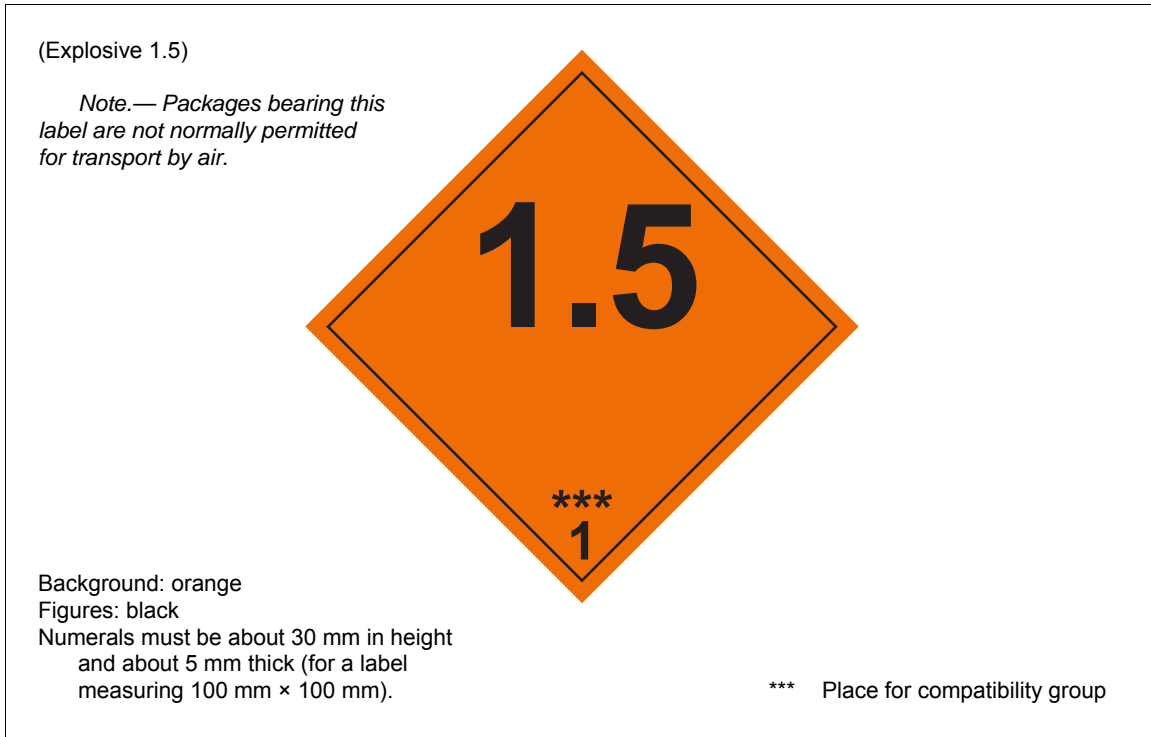

Figure 5-4. Explosive, Class 1, Divisions 1.1, 1.2 and 1.3



Figure 5-5. Explosive, Class 1, Division 1.4



≠ **Figure 5-6. Explosive, Class 1, Division 1.5**

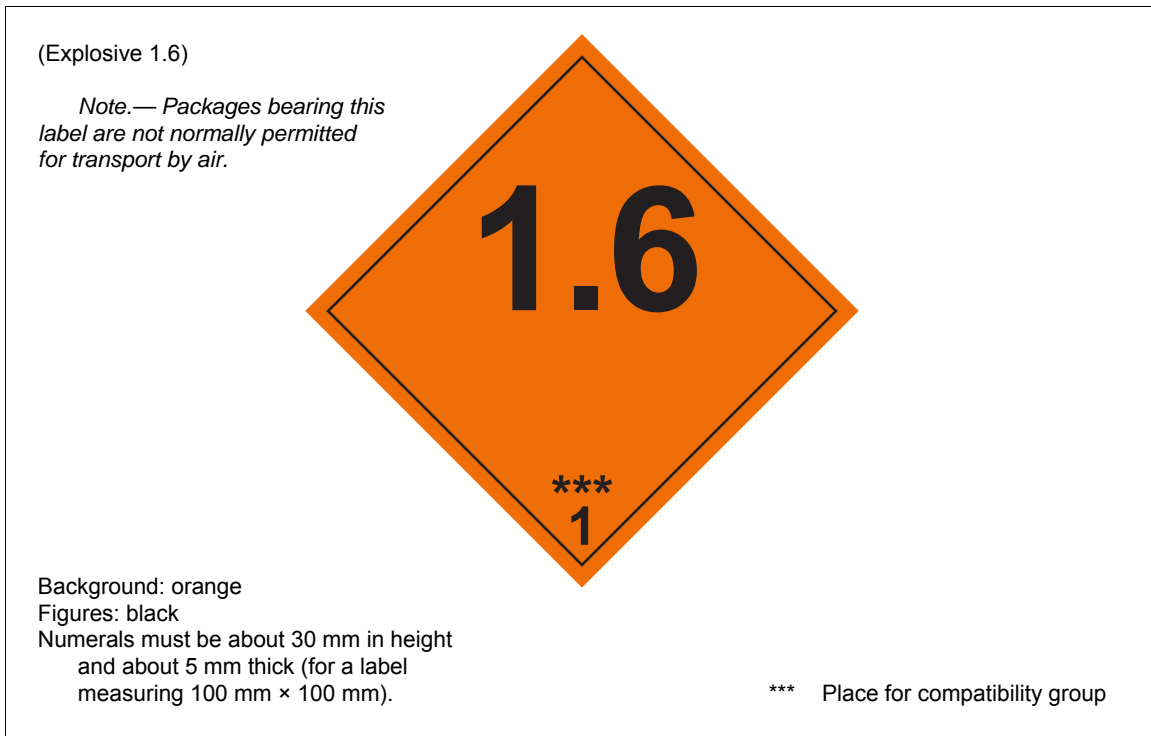

≠ **Figure 5-7. Explosive, Class 1, Division 1.6**



≠

Figure 5-8. Flammable gas, Class 2, Division 2.1

≠

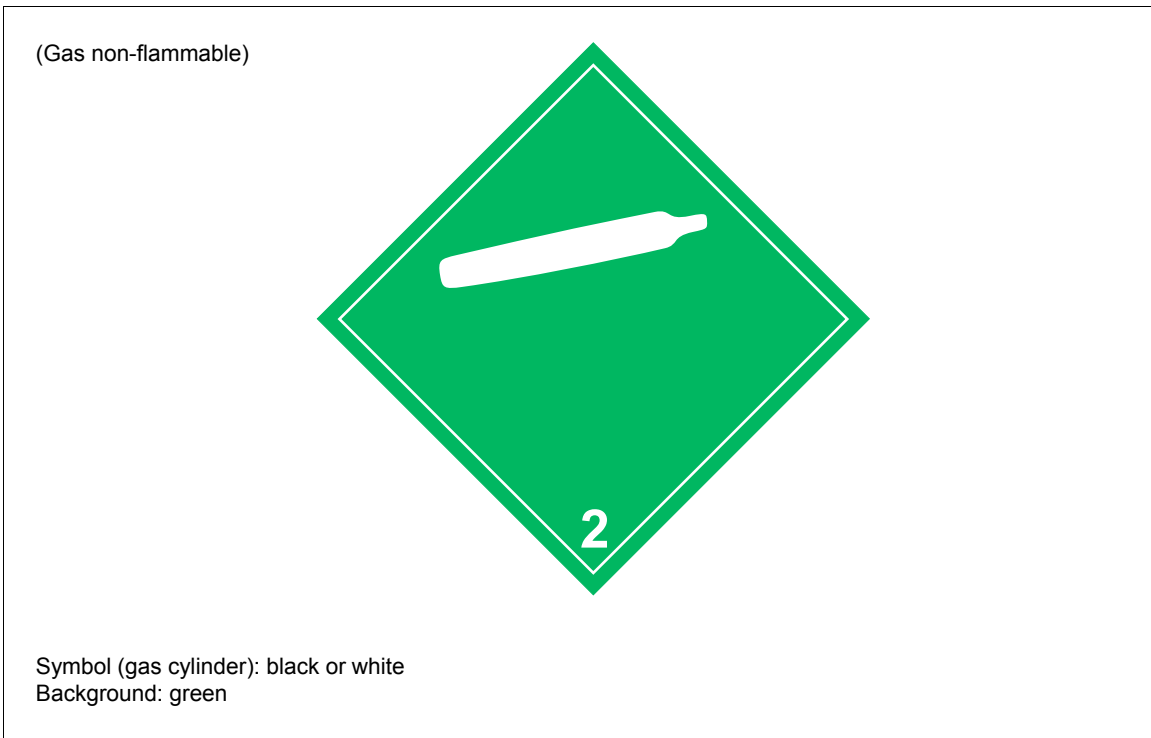

≠

Figure 5-9. Non-flammable, non-toxic gas, Class 2, Division 2.2

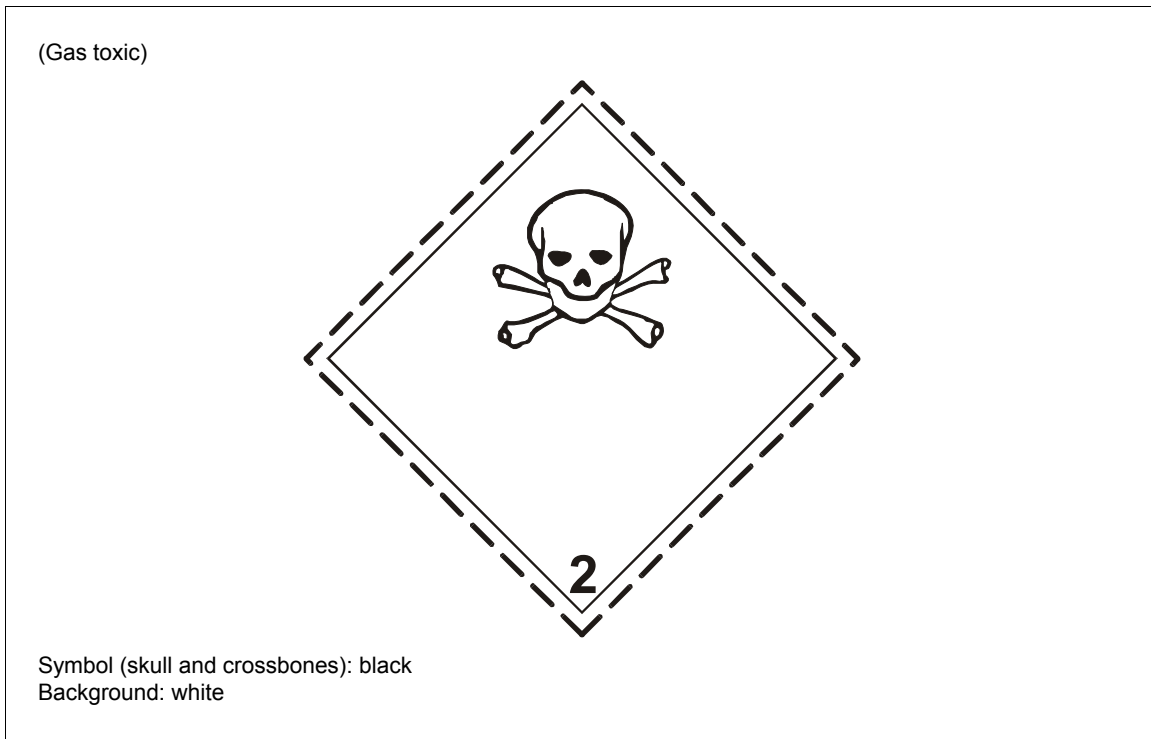

#

Figure 5-10. Toxic gas, Class 2, Division 2.3

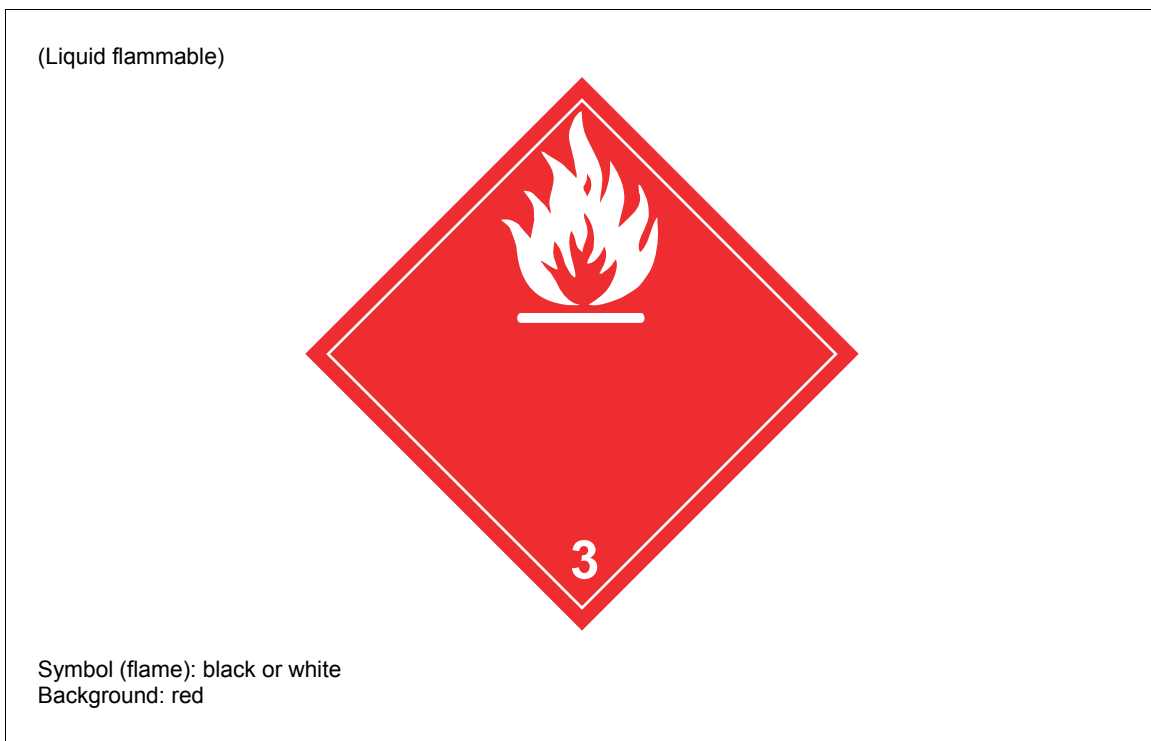

#

Figure 5-11. Flammable liquid, Class 3

≠

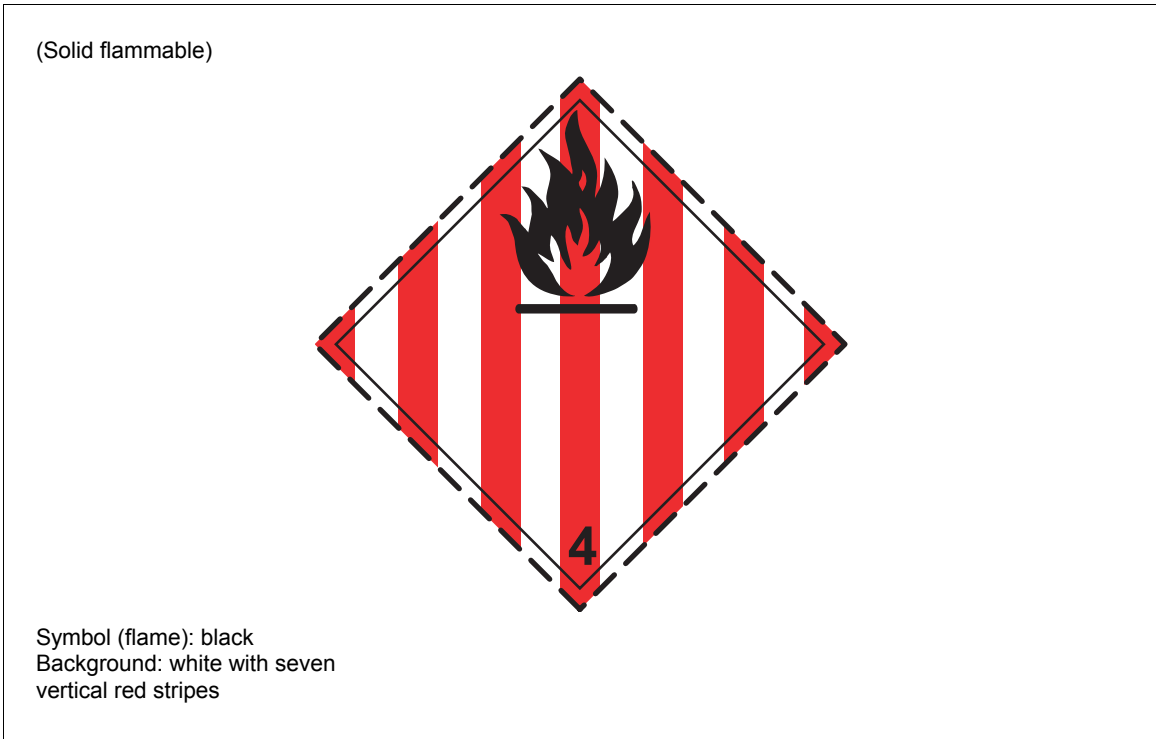

Figure 5-12. Flammable solid, Class 4, Division 4.1

≠

≠

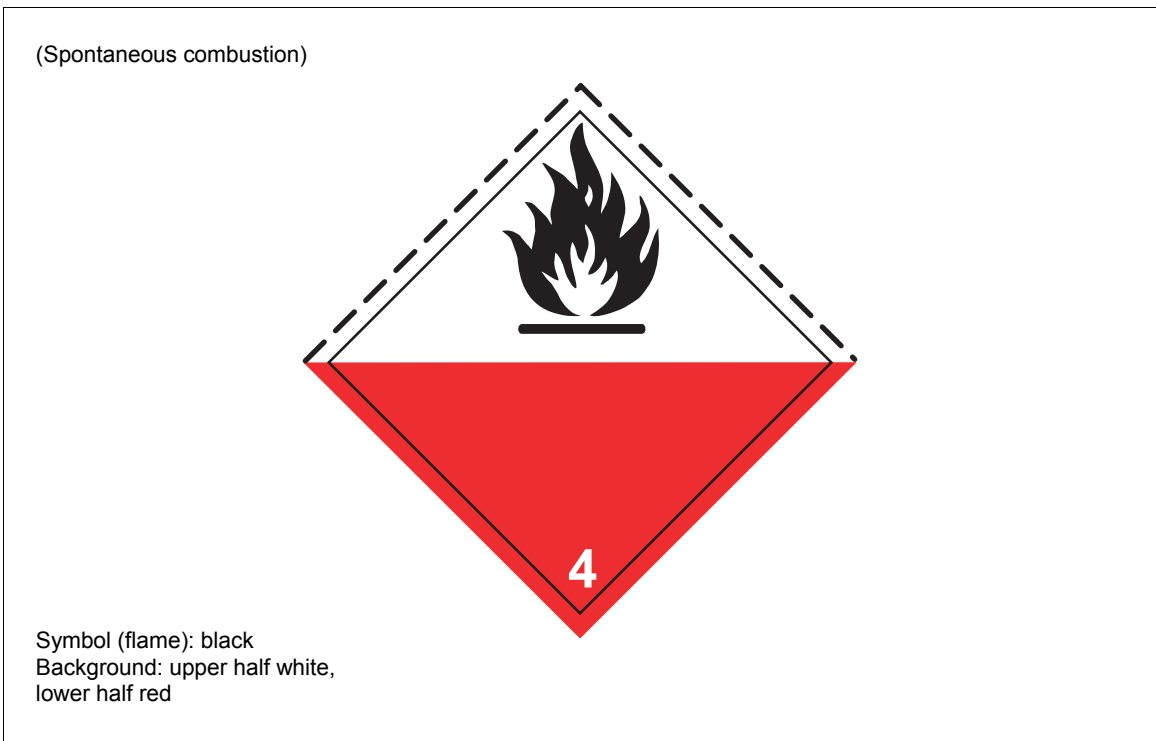
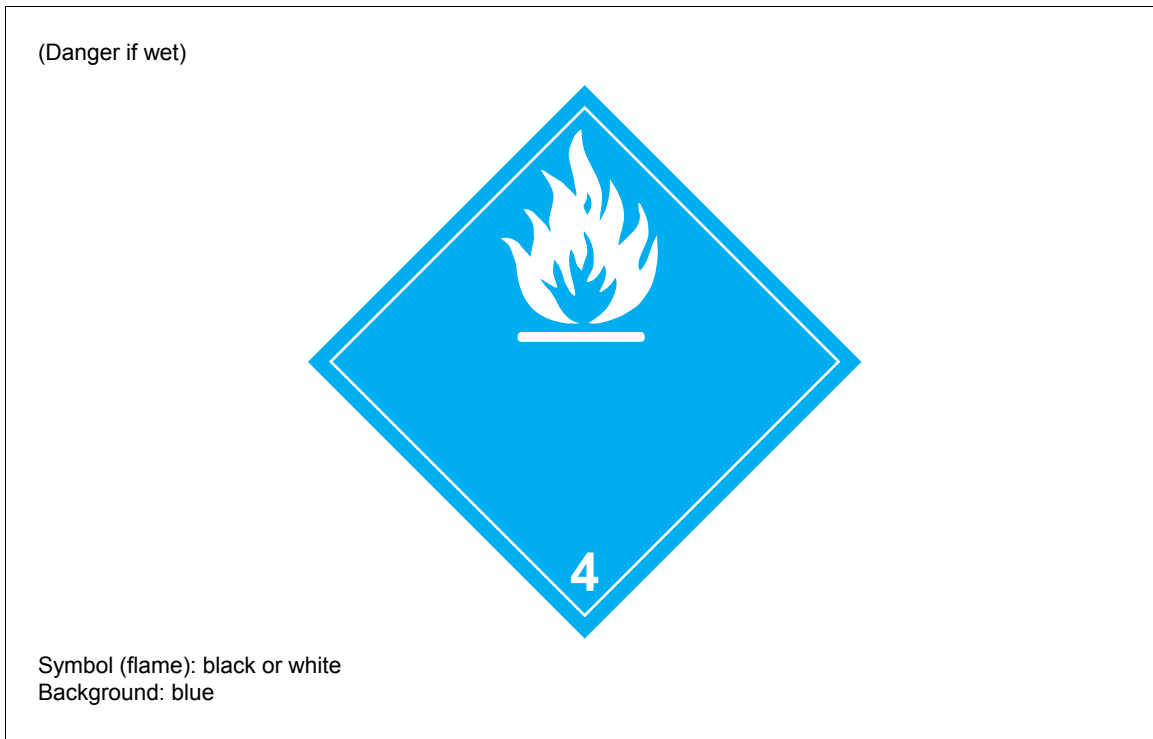

Figure 5-13. Substance liable to spontaneous combustion, Class 4, Division 4.2

≠



≠

Figure 5-14. Substance which, in contact with water, emits flammable gas, Class 4, Division 4.3

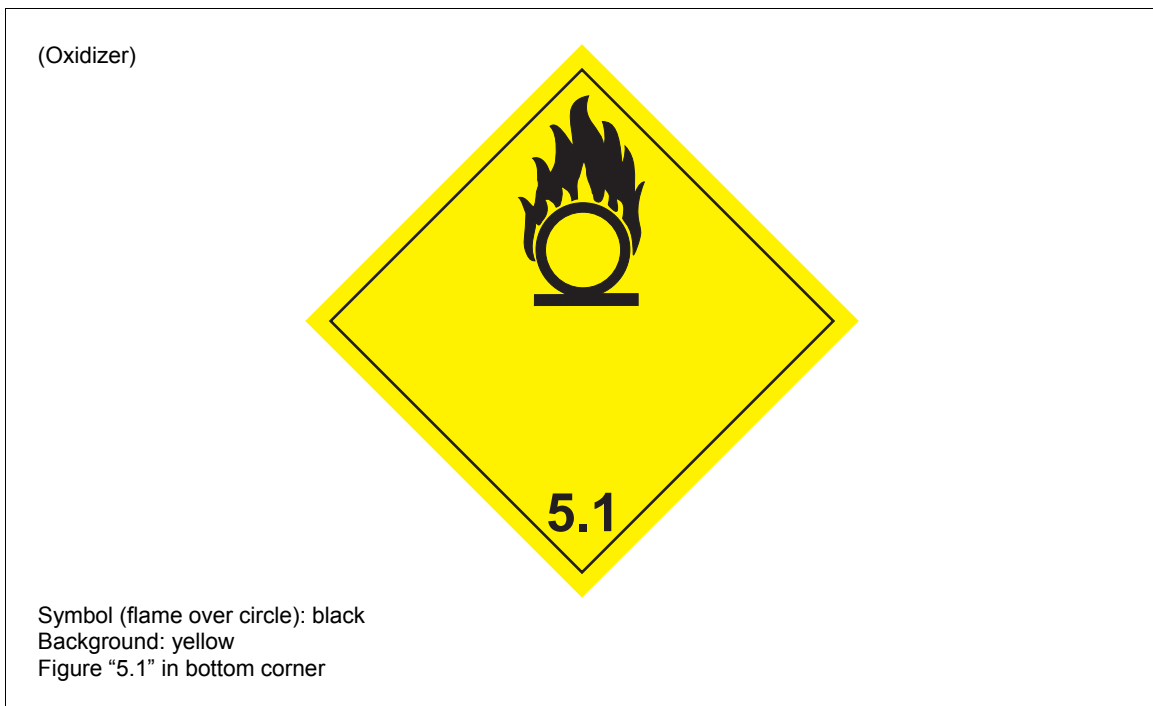

≠

Figure 5-15. Oxidizing substance, Class 5

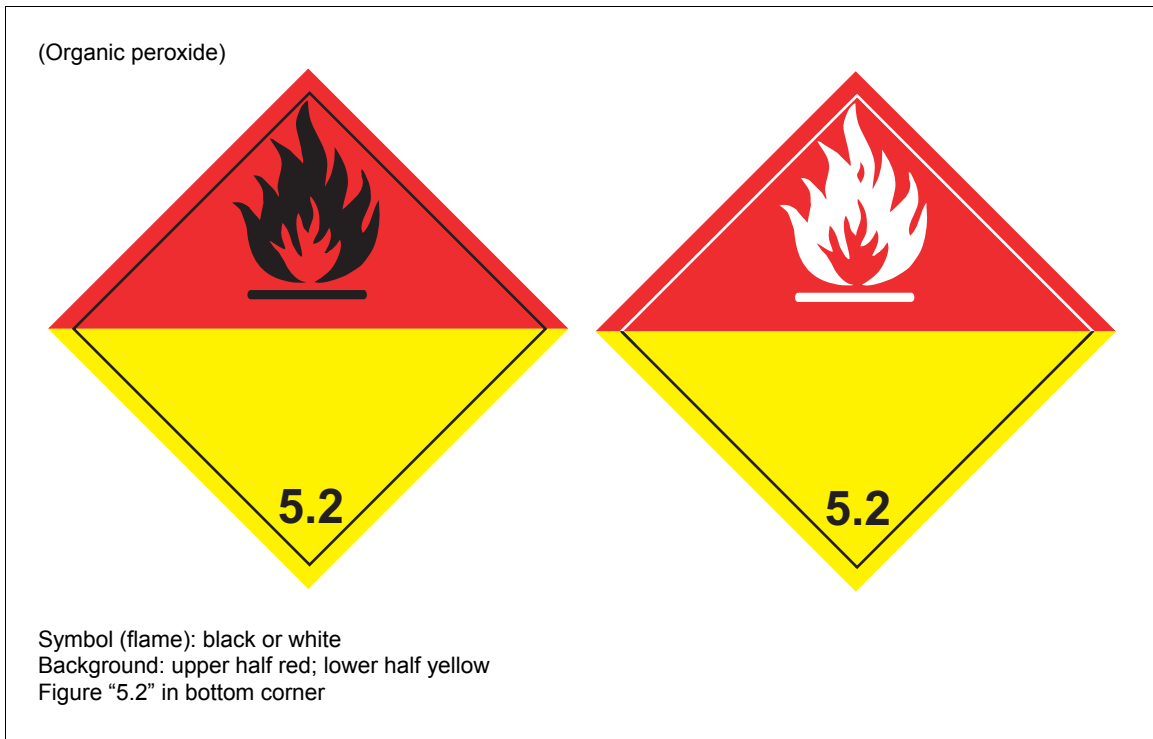

#

Figure 5-16. Organic peroxide, Class 5, Division 5.2

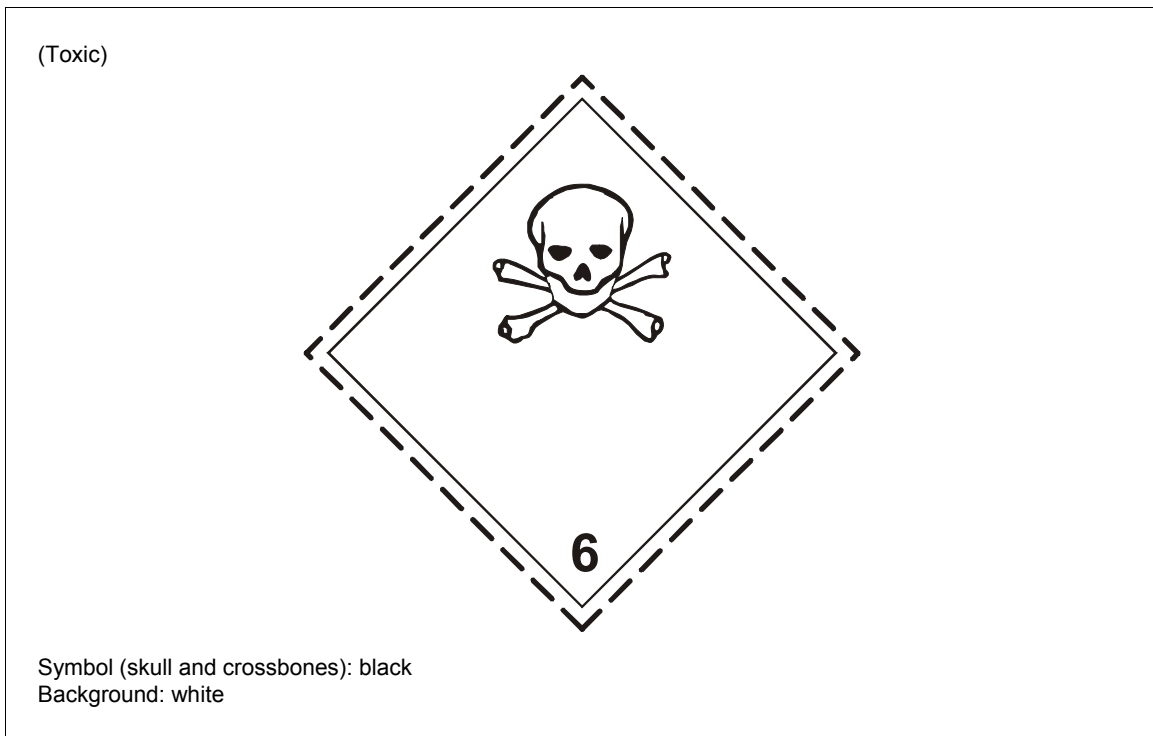

#

Figure 5-17. Toxic substance, Class 6, Division 6.1

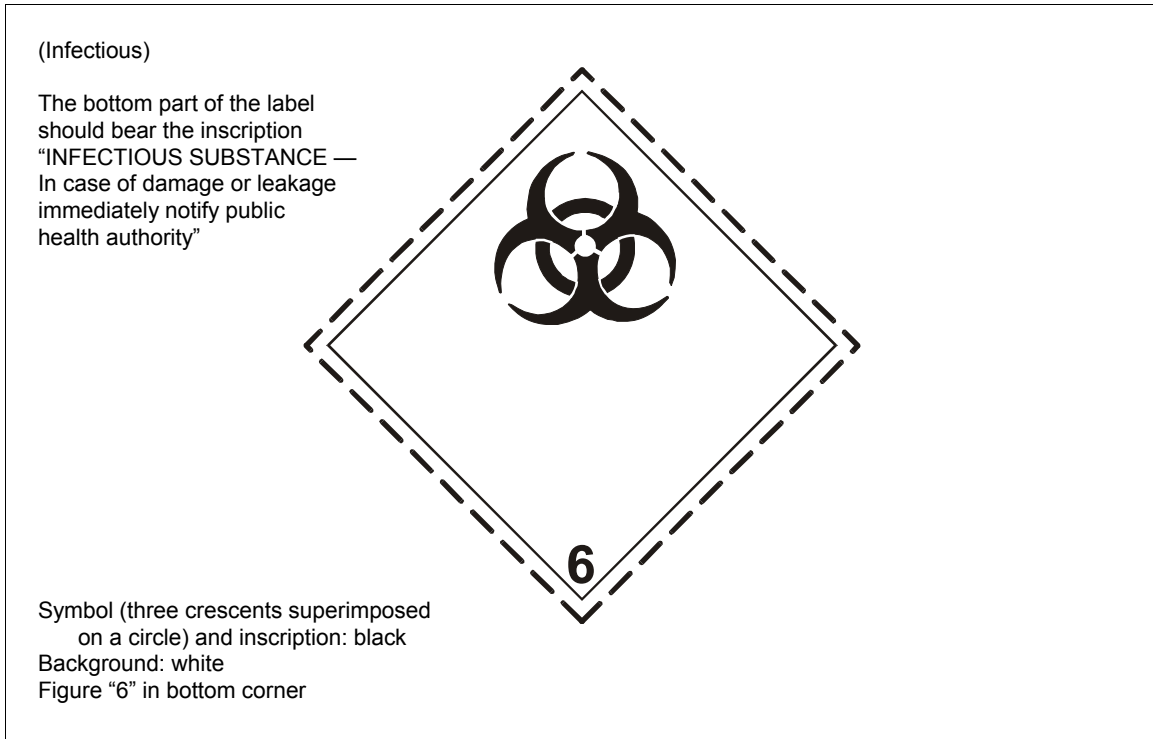

#

Figure 5-18. Infectious substance, Class 6, Division 6.2

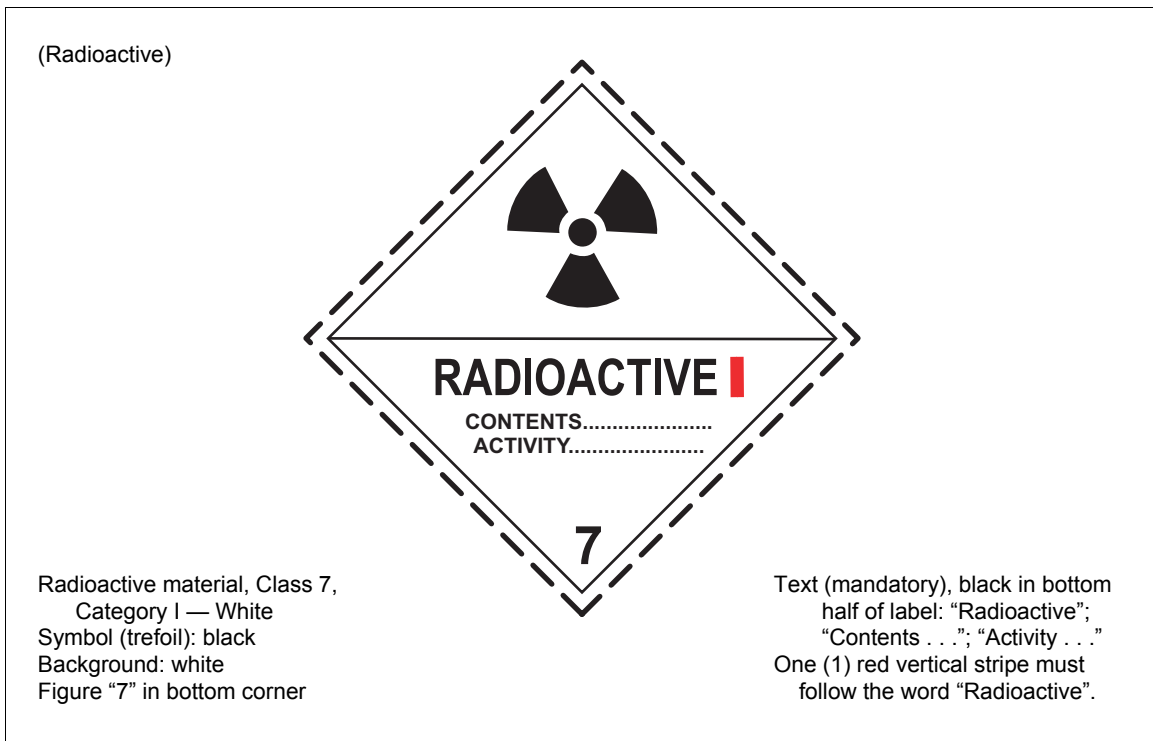

#

Figure 5-19. Radioactive material, Class 7, Category I

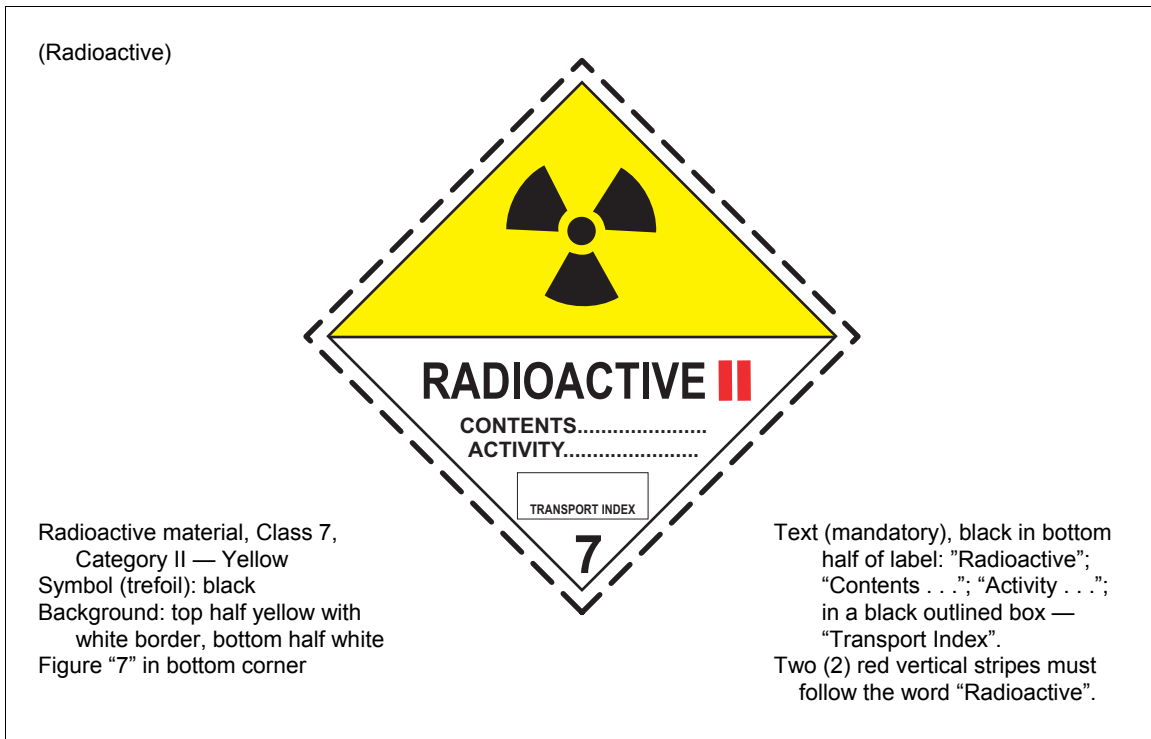

Figure 5-20. Radioactive material, Class 7, Category II

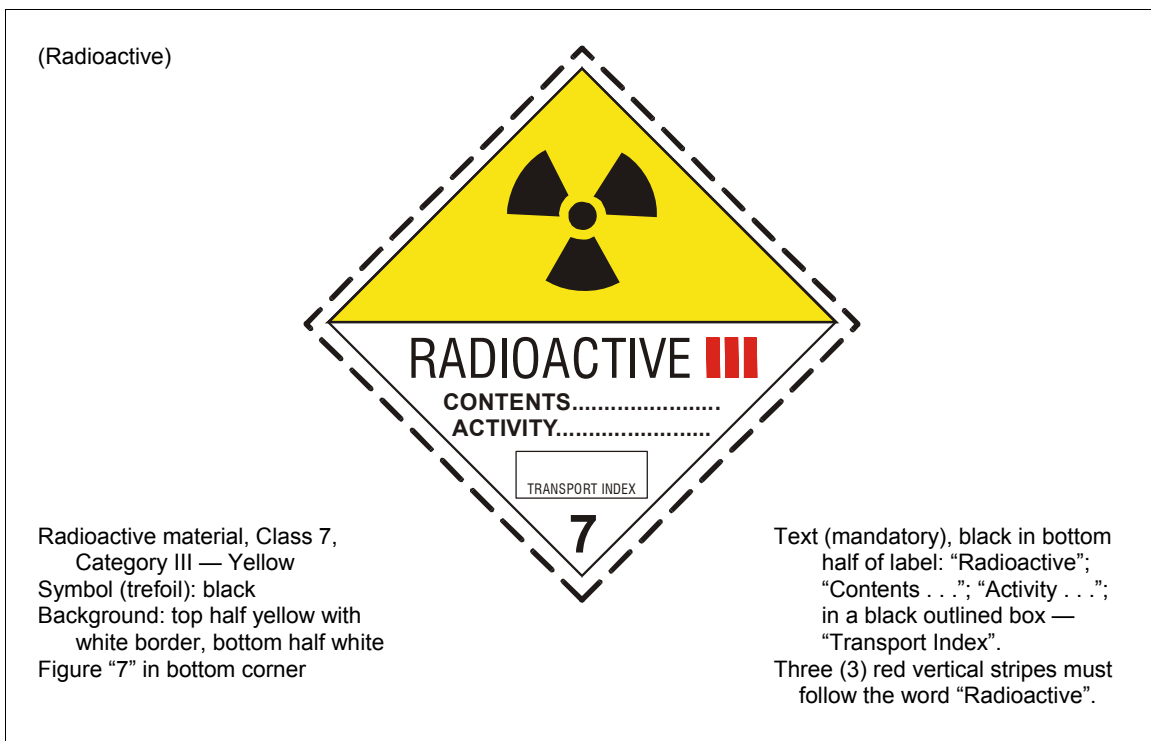

Figure 5-21. Radioactive material, Class 7, Category III

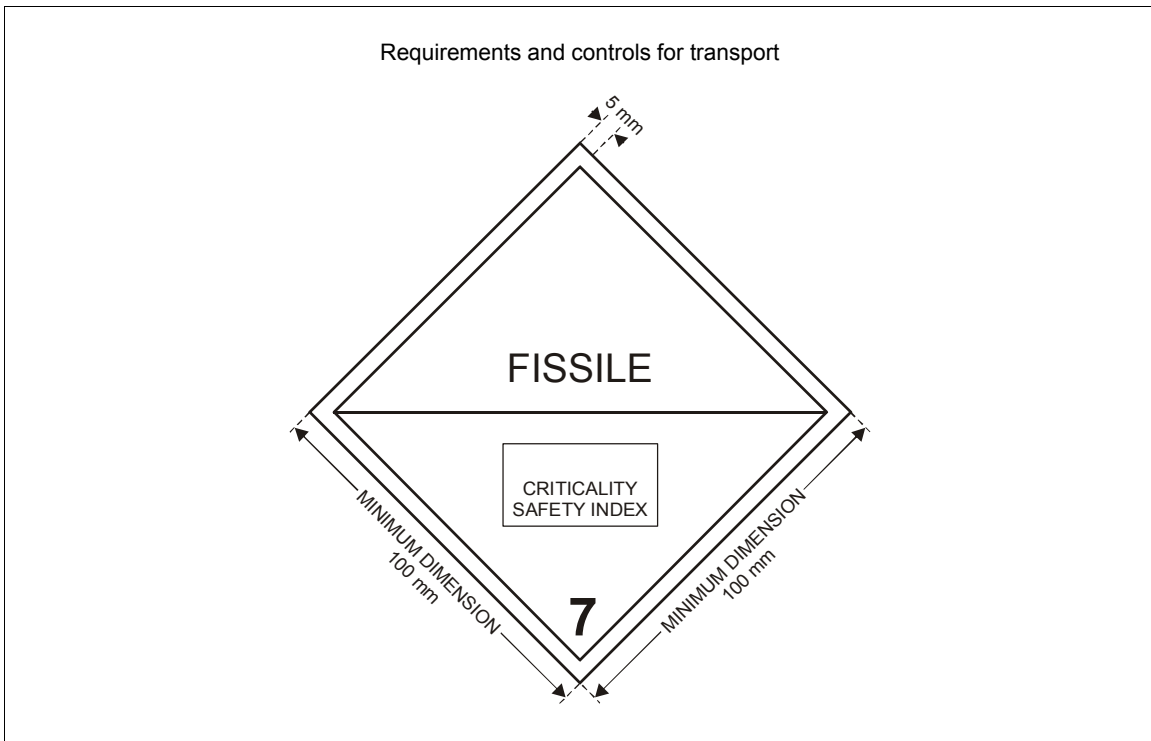

Figure 5-22. Criticality safety index label

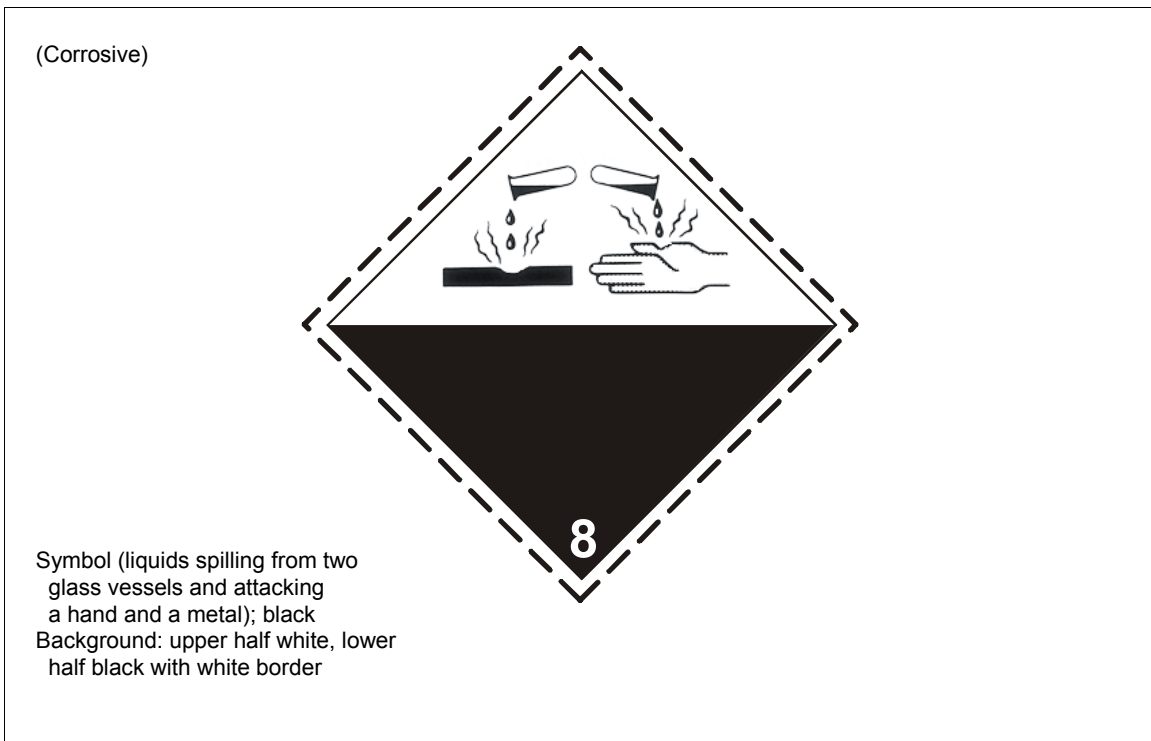

Figure 5-23. Corrosive, Class 8

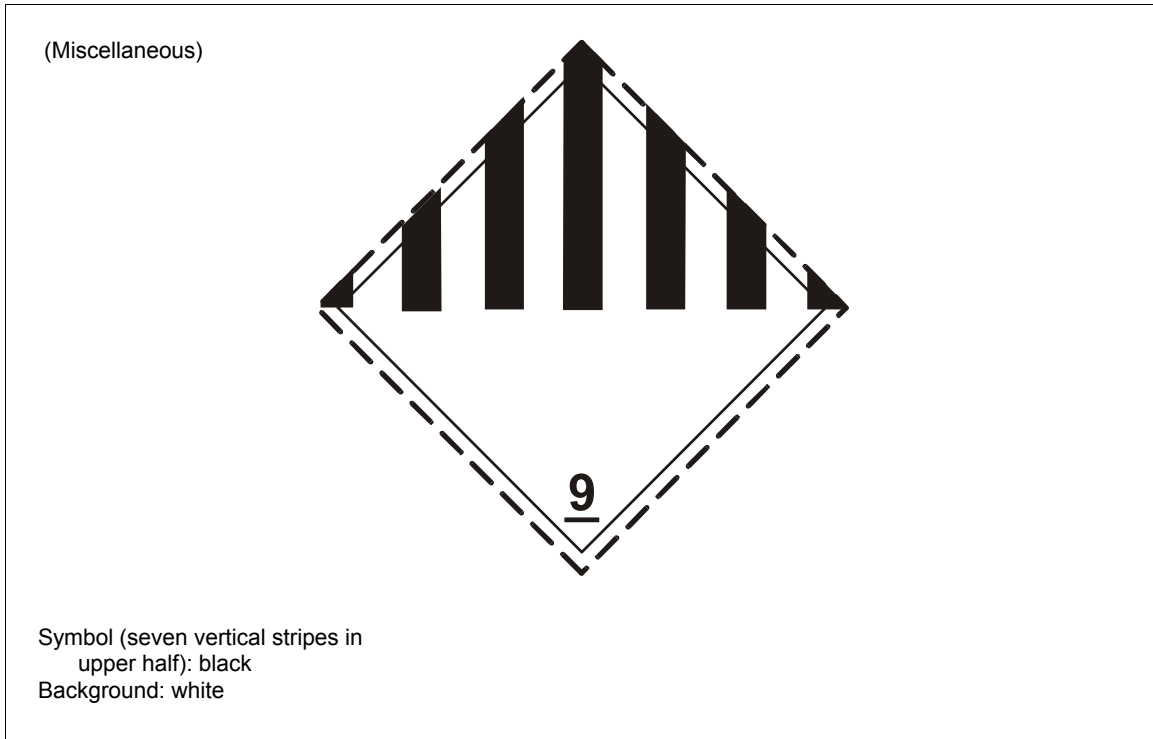

Figure 5-24. Miscellaneous dangerous goods, Class 9

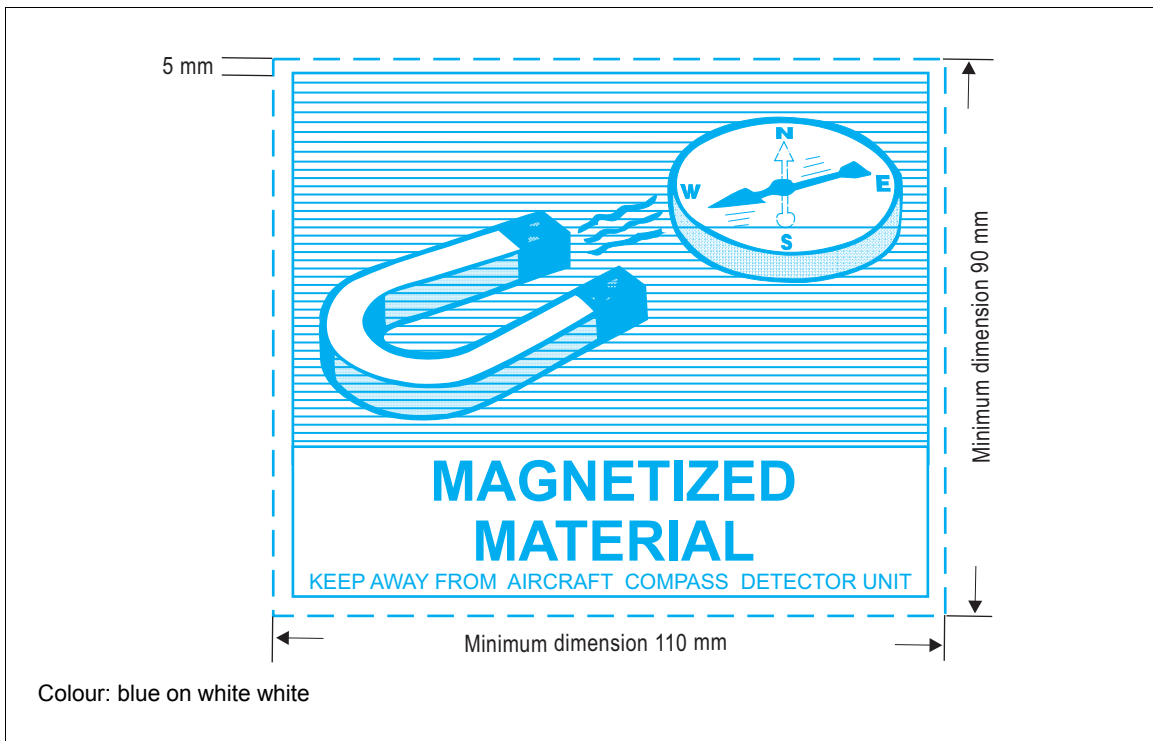

Figure 5-25. Magnetized material

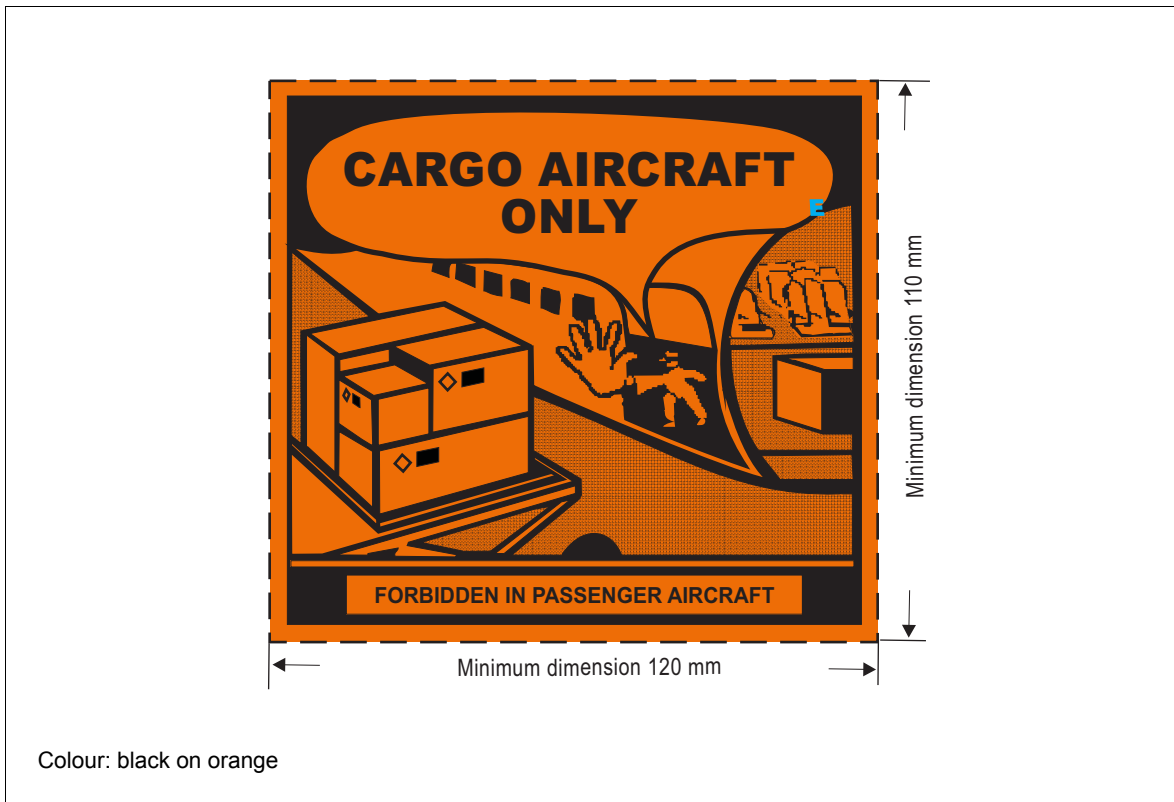

Figure 5-26. Cargo aircraft only

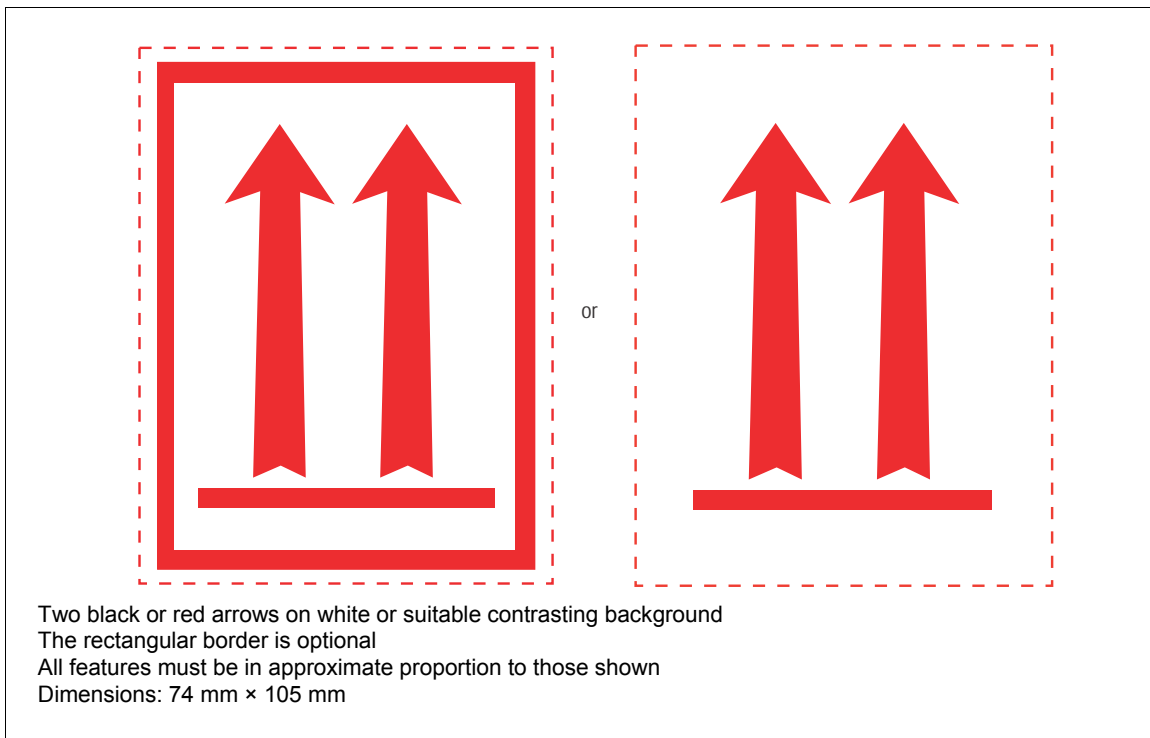

Figure 5-27. Package orientation

#



#

Figure 5-28. Radioactive material, Class 7, placard for large freight containers

#

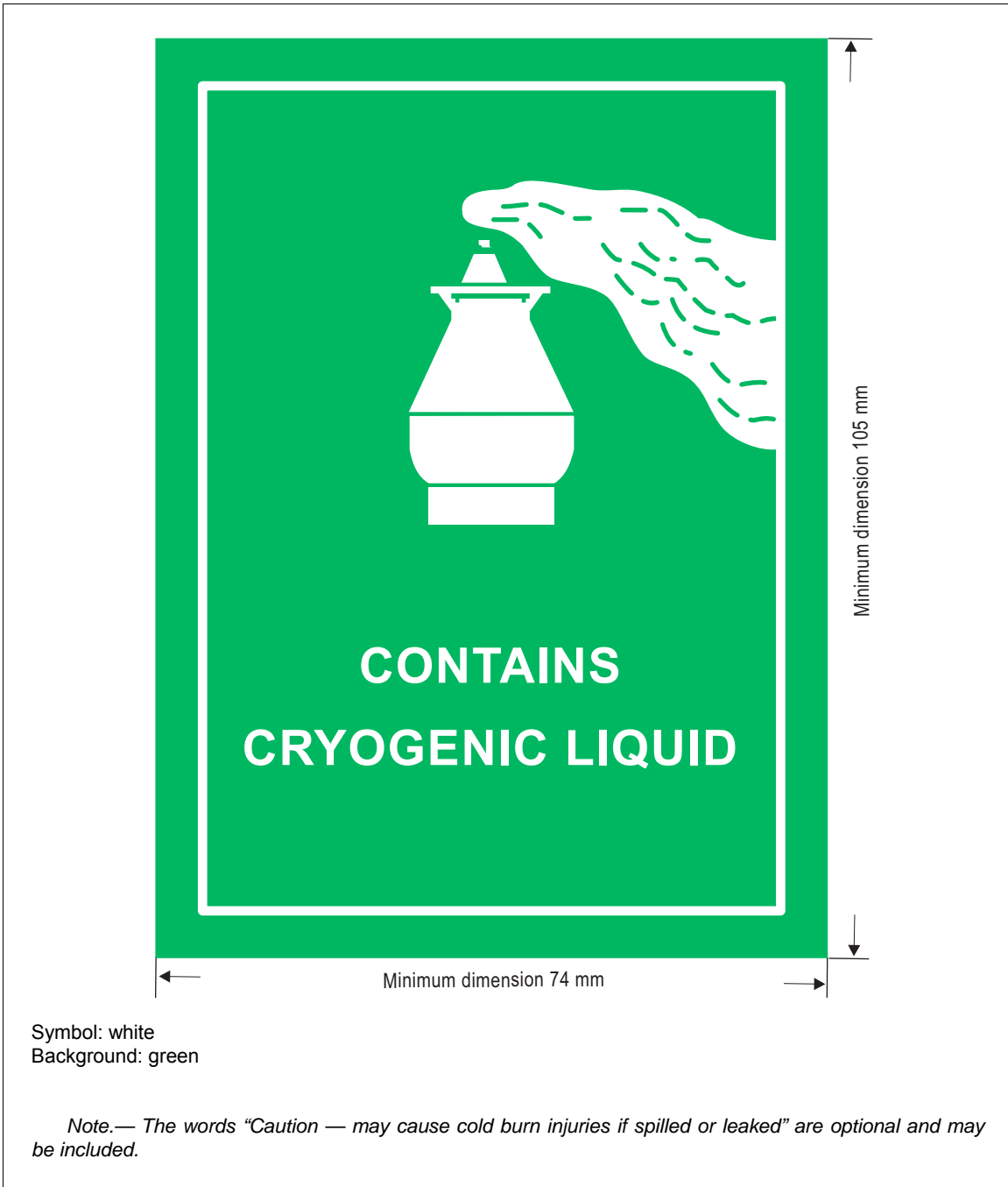

#

Figure 5-29. Cryogenic liquid label

≠

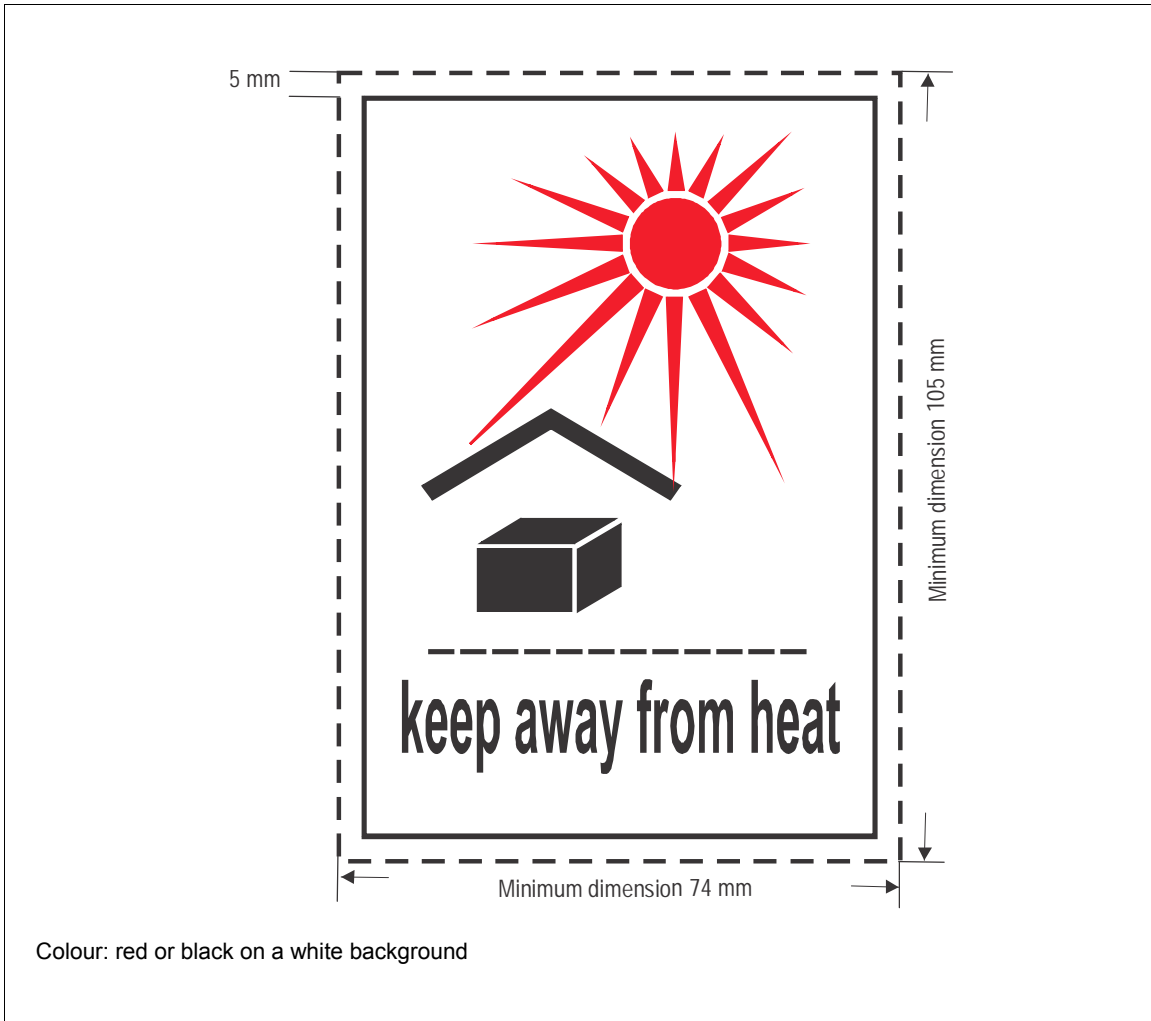

≠

Figure 5-30. Keep away from heat

#

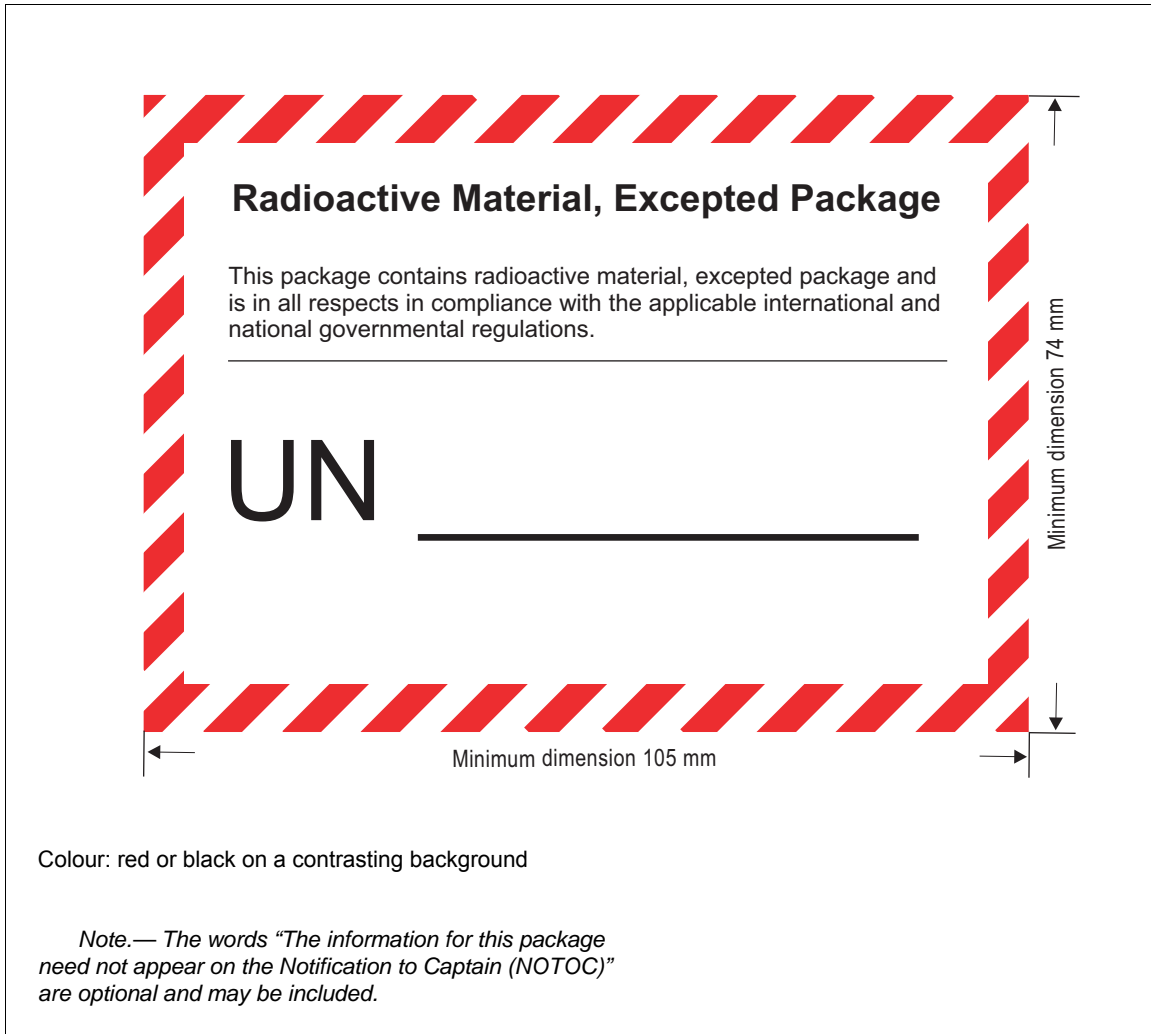

#

Figure 5-31. Radioactive material, excepted package

#



#

Figure 5-32. Lithium battery handling label

Chapter 4

DOCUMENTATION

Parts of this Chapter are affected by State Variations AE 5, AE 7, AU 5, BN 1, BR 3, BR 5, BR 6, BR 8, CA 4, CA 9, DQ 4, ES 1, FR 7, HK 2, JM 2, JM 3, MY 6, PE 3, PK 3, RU 1, US 1, US 7, US 12, VC 7, VU 1, ZA 3; see Table A-1

Note.— These Instructions do not preclude the use of electronic data processing (EDP) and electronic data interchange (EDI) transmission techniques as an alternative to paper documentation. Unless otherwise indicated, all references to “dangerous goods transport document” in this chapter also include provision of the required information by use of EDP and EDI transmission techniques.

4.1 DANGEROUS GOODS TRANSPORT INFORMATION

4.1.1 General

4.1.1.1 The person who offers dangerous goods for transport by air must provide to the operator the information applicable to the consignment as set out in this paragraph. The information may be provided on a paper document or, where an agreement exists with the operator, by EDP or EDI techniques.

4.1.1.2 Where a paper document is used, the person who offers dangerous goods for transport by air must provide to the operator two copies of the dangerous goods transport document, completed and signed as provided for in this paragraph.

4.1.1.3 Where the dangerous goods transport information is provided by EDP or EDI techniques the data must be able to be produced as a paper document without delay, with the data in the sequence required by this chapter.

Note.— All references to “dangerous goods transport document” in this chapter also include provision of the required information by use of EDP and EDI transmission techniques.

4.1.2 Form of the transport document

4.1.2.1 A dangerous goods transport document may be in any form, provided it contains all of the information required by these Instructions.

4.1.2.2 If both dangerous and non-dangerous goods are listed in one document, the dangerous goods must be listed first, or otherwise be emphasized.

4.1.2.3 Continuation page

A dangerous goods transport document may consist of more than one page, provided pages are consecutively numbered.

4.1.2.4 The information on a dangerous goods transport document must be easy to identify, legible and durable.

4.1.3 Shipper and consignee

The name and address of the shipper and the consignee of the dangerous goods must be included on the dangerous goods transport document. For the transport of radioactive material, it is recommended that the telephone number of the consignee is included to facilitate a prompt release at the airport of destination.

4.1.4 Information required on the dangerous goods transport document

4.1.4.1 Dangerous goods description

The dangerous goods transport document must contain the following information for each dangerous substance, material or article offered for transport:

- a) the UN or ID number preceded by the letters “UN” or “ID” as appropriate;

- b) the proper shipping name, as determined according to 3;1.2, including the technical name enclosed in parenthesis, as applicable (see 3;1.2.7);
- c) the primary hazard class or, when assigned, the division of the goods, including for Class 1 the compatibility group letter. The words "Class" or "Division" may be included preceding the primary hazard class or division numbers;
- d) subsidiary hazard class or division number(s) corresponding to the subsidiary risk label(s) required to be applied, when assigned, must be entered following the primary hazard class or division and must be enclosed in parenthesis. The words "Class" or "Division" may be included preceding the subsidiary hazard class or division numbers;
- e) where assigned, the packing group for the substance or article which may be preceded by "PG" (e.g. "PG II").

4.1.4.2 Sequence of the dangerous goods description

The five elements of dangerous goods description specified in 4.1.4.1 must be shown in the order listed above (i.e. a), b), c), d), e)), with no information interspersed, except as provided in these Instructions. Examples of a dangerous goods description are:

"UN 1717 Acetyl chloride 3 (8) II" or
 "UN 1717 Acetyl chloride, Class 3 (Class 8), PG II"

Note 1.— In addition to the requirements of these Instructions, other elements of information may be required by the appropriate national authority or for certain modes of transport (e.g. flash point for sea transport). Unless permitted or required by these Instructions, additional information must be placed after the dangerous goods description.

Note 2.— Additional descriptive text in the entries in column 1 of the Dangerous Goods List (Table 3-1) are not part of the proper shipping name but may be used in addition to the proper shipping name.

Note 3.— For explosives of Class 1, the basic dangerous goods description may be supplemented by additional descriptive text to indicate commercial or military names.

4.1.4.3 Information which supplements the proper shipping name in the dangerous goods description

The proper shipping name in the dangerous goods description must be supplemented as follows:

- a) *Technical names for "n.o.s." and other generic descriptions:* Proper shipping names that are assigned an asterisk in column 1 of the Dangerous Goods List must be supplemented with their technical or chemical group names as described in 3;1.2.7;
- b) *Empty uncleaned packagings:* Empty means of containment which contain the residue of dangerous goods of classes other than Class 7 must be described as such by, for example, placing the words "Empty uncleaned" or "Residue last contained" before or after the dangerous goods description specified in 4.1.4.1 a) to e);
- c) *Wastes:* For waste dangerous goods (other than radioactive wastes) which are being transported for disposal, or for processing for disposal, the proper shipping name must be preceded by the word "Waste", unless this is already a part of the proper shipping name;
- d) *Elevated temperature substances:* For solid substances, unless the word "Molten" is already included in the proper shipping name, it must be added to the proper shipping name on the dangerous goods transport document when a substance is offered for air transport in the molten state (see Part 3, Chapter 1).

4.1.5 Information required in addition to the dangerous goods description

In addition to the dangerous goods description the following information must be included after the dangerous goods description on the dangerous goods transport document.

4.1.5.1 Quantity of dangerous goods, number and type of packagings

The number of packages, type of packaging (e.g. steel drum, fibreboard box, etc.) and net quantity of dangerous goods in each package (by volume or mass, as appropriate) must be indicated for each item of dangerous goods bearing a different proper shipping name, UN number or packing group. Abbreviations may be used to specify the unit of measurement for the quantity. For packages containing the same dangerous goods and quantity per package a multiple of the quantity may be used. For example:

UN 1263, Paint, 3, PG II, 5 fibreboard boxes x 5 L

Consignment comprising packages of different quantities of the same dangerous good must be clearly identified. For example:

UN 1263, Paint, 3, PG II, 5 fibreboard boxes x 5 L, 10 fibreboard boxes x 10 L

UN packaging codes may only be used to supplement the description of the kind of package (e.g. one fibreboard box (4G)). For limited quantities, where the letter "G" follows the quantity in column 11 of Table 3-1, and for shipments made under the provisions of Section IB of Packing Instruction 965 (UN 3480, **Lithium ion batteries**) and Packing Instruction 968 (UN 3090, **Lithium metal batteries**), the gross mass of each package must be indicated, rather than the net quantity (except when there are different dangerous goods packed together in the same outer packaging which must be described as shown in paragraph e)) and:

- a) for empty uncleaned packagings as described by 4.1.4.3 b) only the number and type of packagings need be shown;
- b) for chemical kits and first aid kits, the total net mass of dangerous goods. Where the kits contain solids and/or liquids, the net mass of liquids within the kits is to be calculated on a 1 to 1 basis of their volume, i.e. 1 litre equal to 1 kilogram;
- c) for dangerous goods in machinery or apparatus, the individual total quantities of dangerous goods in solid, liquid or gaseous state, contained in the article;
- d) for dangerous goods transported in salvage packagings, an estimate of the quantity of dangerous goods must be given;
- e) for dangerous goods in limited quantities with a 30 kg G limit in Table 3-1, and for shipments made under the provisions of Section IB of Packing Instruction 965 (UN 3480, **Lithium ion batteries**) and Packing Instruction 968 (UN 3090, **Lithium metal batteries**), where different dangerous goods are packed together in the same outer packaging, the net quantity of each dangerous goods followed by the gross mass of the completed package;
- f) for explosive articles of Class 1, the net quantity indicated for each package must be supplemented with the net explosive mass (see Part 1;3.1.1 for the definition of net explosive mass) contained in the package followed by the unit of measurement. The abbreviations "NEQ", "NEM" or "NEW" may be indicated in association with the value provided.

Note.— The number, type and capacity of each inner packaging within the outer packaging of a combination packaging is not required to be indicated.

4.1.5.2 Salvage packagings

For dangerous goods transported in salvage packagings, the words "Salvage package" must be included.

4.1.5.3 Chemical oxygen generators

When chemical oxygen generators contained in protective breathing equipment (PBE) are being transported under Special Provision A144, the statement "Aircrew protective breathing equipment (smoke hood) in accordance with Special Provision A144" must be included on the dangerous goods transport document.

4.1.5.4 Self-reactive substances and organic peroxides

4.1.5.4.1 When organic peroxides and self-reactive substances are transported under conditions where approval is required (for organic peroxides, see 2;5.3.2.5 for self-reactive substances, see 2;4.2.3.2.5), a statement to this effect must be included in the dangerous goods transport document. A copy of the classification approval and conditions of transport for non-listed organic peroxides and self-reactive substances must be attached to the dangerous goods transport document.

4.1.5.4.2 When a sample of an organic peroxide (see 2;5.3.2.6) or a self-reactive substance (see 2;4.2.3.2.6) is transported, a statement to this effect must be included in the dangerous goods transport document.

4.1.5.5 Infectious substances and controlled substances

The dangerous goods transport document must also include the name and telephone number of a responsible person when a national law or international convention prohibits the disclosure of the technical name following an "n.o.s.*" entry or for infectious substances, UN 2814 and UN 2900.

4.1.5.6 Firework classification reference

4.1.5.6.1 When fireworks of UN 0336 or UN 0337 are transported, the dangerous goods transport document must include a classification reference(s) issued by the appropriate national authority.

4.1.5.6.2 The classification reference(s) must consist of the appropriate national authority's State, indicated by the distinguishing sign for motor vehicles in international traffic, the appropriate national authority identification and a unique serial reference. Examples of such classification references are:

GB/HSE123456
D/BAM1234
USA EX20091234.

4.1.5.7 Radioactive material

4.1.5.7.1 The following information must be included for each consignment of Class 7 material, as applicable, in the order given:

- a) The name or symbol of each radionuclide or, for mixtures of radionuclides, an appropriate general description or a list of the most restrictive nuclides;
- b) A description of the physical and chemical form of the material, or a notation that the material is special form radioactive material or low dispersible radioactive material. A generic chemical description is acceptable for chemical form;

+ *Note.— For empty Type B(U) or Type B(M) packages as specified in the Note to 2;7.2.4.1.1.7, the name or symbol of the radionuclide of the shielding material followed by the physical and chemical form must be included (e.g. U-dep., solid, metal oxide) in which case the indicated radionuclide may differ from the radionuclide(s) authorized in the package design certificate.*

- c) The maximum activity of the radioactive contents during transport expressed in units of becquerels (Bq) with an appropriate SI prefix symbol (see 1;3.2). For fissile material, the mass of fissile material (or mass of each fissile nuclide for mixtures when appropriate) in units of grams (g), or appropriate multiples thereof, may be used in place of activity;
- d) The category of the package, i.e. I-WHITE, II-YELLOW, III-YELLOW;
- e) The transport index (categories II-YELLOW and III-YELLOW only);
- ≠ f) For fissile material:
 - + 1) shipped under one exception of 2;7.2.3.5.1 a) to f), reference to that paragraph;
 - + 2) shipped under 2;7.2.3.5.1 c) to e), the total mass of fissile nuclides;
 - + 3) contained in a package for which one of 6;7.10.2 a) to c) or 6;7.10.3 is applied, reference to that paragraph; and
 - + 4) the criticality safety index, where applicable.
- ≠ g) The identification mark for each competent authority certificate of approval (special form radioactive material, low dispersible radioactive material, fissile material excepted under 2;7.2.3.5.1 f), special arrangement, package design, or shipment) applicable to the consignment;
- h) For consignments of more than one package, the information contained in 4.1.4.1 a) to c) and 4.1.5.7.1 a) to g) must be given for each package. For packages in an overpack or freight container, a detailed statement of the contents of each package within the overpack or freight container and, where appropriate, of each overpack or freight container must be included. If packages are to be removed from the overpack or freight container at a point of intermediate unloading, appropriate transport documents must be made available;
- i) Where a consignment is required to be shipped under exclusive use, the statement "EXCLUSIVE USE SHIPMENT"; and
- j) For LSA-II, LSA-III, SCO-I and SCO-II, the total activity of the consignment as a multiple of A_2 . For radioactive material for which the A_2 value is unlimited, the multiple of A_2 must be zero.

4.1.5.7.2 The shipper must provide a statement regarding actions, if any, that are required to be taken by the carrier. The statement must be in the languages deemed necessary by the carrier or the authorities concerned, and must include at least the following points:

- ≠ a) Supplementary requirements for loading, stowage, carriage, handling and unloading of the package, overpack or freight container including any special stowage provisions for the safe dissipation of heat (see 7;2.9.3.2), or a statement that no such requirements are necessary;
- b) Restrictions on the type of aircraft and any necessary routing instructions;
- c) Emergency arrangements appropriate to the consignment.

≠ 4.1.5.7.3 In all cases of international transport of packages requiring competent authority approval of design or shipment, for which different approval types apply in the different countries concerned by the shipment, the UN number and proper shipping name required in 4.1.4.1 must be in accordance with the certificate of the country of origin of design.

4.1.5.7.4 The applicable competent authority certificates need not necessarily accompany the consignment. The shipper must make them available.

4.1.5.8 Additional requirements

4.1.5.8.1 The dangerous goods transport document must also contain:

+ a) except for radioactive material, the packing instruction applied. For shipments of lithium batteries prepared in accordance with Section IB of Packing Instruction 965 or Packing Instruction 968, the letters "IB" must be added following the packing instruction number;

≠ b) when applicable, reference to Special Provision A1, A2, A4 or A5;

≠ c) a statement indicating that the shipment is within the limitations prescribed for either passenger and cargo aircraft or cargo-only aircraft, as appropriate;

Note.— To qualify as acceptable for transport aboard passenger aircraft, passenger aircraft packing instruction number(s) must be used, and the package must not bear the "Cargo aircraft only" label. To qualify as acceptable for transport aboard cargo-only aircraft, cargo aircraft packing instruction number(s) must be used, and the package must bear the "Cargo aircraft only" label; or passenger aircraft instruction number(s) must be shown and no "Cargo aircraft only" label applied. However, where the packing instruction number(s) and the permitted quantity per package are identical for passenger and cargo aircraft, the "Cargo aircraft only" label should not be used.

≠ d) special handling information, when appropriate;

≠ e) an indication that an overpack has been used, when appropriate; and

≠ f) the "Q" value rounded up to the first decimal place, if substances are packed in accordance with 3;4.3.3 or 4;1.1.9 e).

4.1.5.8.2 For explosive substances, where Packing Instruction 101 has been adopted by an appropriate national authority, the State's distinguishing sign for motor vehicles in international traffic of the country for which the authority acts must be marked on the dangerous goods transport document as follows:

Packaging authorized by the competent authority of ...

Note.— In this instance, the term "competent authority" is used for intermodal compatibility; it refers to the appropriate national authority.

4.1.5.8.3 When self-reactive substances of Division 4.1, or organic peroxides of Division 5.2 or other substances having similar properties, are offered for transport, the shipper must indicate on the dangerous goods transport document that the packages containing such substances must be protected from direct sunlight and all sources of heat and be placed in adequately-ventilated areas.

4.1.6 Certification

4.1.6.1 The dangerous goods transport document must include a certification or declaration that the consignment is acceptable for transport and that the goods are properly packaged, marked and labelled, and in proper condition for transport in accordance with the applicable regulations and including additional air transport requirements of these Instructions (examples of additional air transport requirements are indicated in 5;1.1).

The text for this certification is:

"I hereby declare that the contents of this consignment are fully and accurately described above by the proper shipping name, and are classified, packaged, marked and labelled/placarded, and are in all respects in proper condition for transport according to applicable international and national governmental regulations."

For air transport the following additional statement is required:

"I declare that all of the applicable air transport requirements have been met."

The certification must be signed and dated by the shipper. Facsimile signatures are acceptable where applicable laws and regulations recognize the legal validity of facsimile signatures.

Note.— The word "placarded" is not essential for shipments by air.

4.1.6.2 If the dangerous goods documentation is presented to the operator by means of EDP or EDI transmission techniques, the signature(s) may be electronic signature(s) or may be replaced by the name(s) (in capitals) of the person authorized to sign. Where the original consignment details are provided to an operator, by EDP or EDI techniques, and subsequently the consignment is transhipped to an operator that requires a paper dangerous goods transport document, the operator must ensure the paper document indicates "Original Received Electronically" and the name of the signatory must be shown in capital letters.

4.1.6.3 In addition to the languages which may be required by the State of Origin, English should be used for the dangerous goods transport document.

4.2 AIR WAYBILL

When an air waybill is issued for a consignment for which a dangerous goods transport document is required, the air waybill must contain a statement to indicate that the dangerous goods are described on an accompanying dangerous goods transport document. An air waybill issued for a consignment must, when applicable, indicate that the consignment must be loaded on cargo aircraft only.

4.3 ADDITIONAL DOCUMENTATION FOR OTHER THAN RADIOACTIVE MATERIAL

4.3.1 When dangerous goods are shipped as authorized by Special Provision A1 or A2, they must be accompanied by a copy of the document(s) of approval, showing the quantity limitations, the packing requirements and, in the case of A2, the labelling requirements.

4.3.2 When dangerous goods are shipped in portable tanks as authorized by Part S-4, Chapter 12 of the Supplement, they must be accompanied by a copy of the document(s) of approval.

4.3.3 When dangerous goods are shipped in packagings as authorized by 4;2.8, they must be accompanied by a copy of the document(s) of approval.

4.3.4 When organic peroxides and self-reactive substances require an approval prior to transport under the provisions of 2;5.3.2.5 or 2;4.2.3.2.5, a copy of the approval must be attached to the dangerous goods transport document.

4.3.5 When dangerous goods are shipped under exemption (see 1;1.1.2), a copy of the exemption must accompany the consignment. Where more than one State has granted an exemption for a particular consignment, the documents that need to accompany it are the exemptions granted by the States of Origin, transit (if relevant) and destination.

4.4 RETENTION OF DANGEROUS GOODS TRANSPORT INFORMATION

4.4.1 The shipper must retain a copy of the dangerous goods transport document and additional information and documentation as specified in these Instructions, for a minimum period of three months.

4.4.2 When the documents are kept electronically or in a computer system, the shipper must be able to reproduce them in a printed form.

Part 6

**PACKAGING NOMENCLATURE, MARKING,
REQUIREMENTS AND TESTS**

Chapter 1

APPLICABILITY, NOMENCLATURE AND CODES

1.1 APPLICABILITY

1.1.1 The applicability of each Chapter of this Part to the packagings for the various Classes and Divisions of dangerous goods is as set out in Table 6-1.

Table 6-1. Applicability of Chapters

<i>Class or Division</i>	<i>Chapter</i>
Classes 1, 2, 3, 4, 5, 8 and 9 and Division 6.1, where the packing instructions for these Classes and Divisions require the use of a packaging marked in accordance with Chapter 2 of this Part	1 to 5
Division 6.2, infectious substances	2, 6
Class 7, radioactive material	7

1.1.2 The requirements for packagings in Chapter 3 are based on packagings currently used. In order to take into account progress in science and technology, there is no objection to the use of packagings having specifications different from those in Chapter 3, provided they are equally effective, acceptable to the appropriate authority and able successfully to withstand the tests described in 4;1.1.18 and Chapter 4. Methods of testing other than those described in these Instructions are acceptable, provided they are equivalent.

1.1.3 Manufacturers and subsequent distributors of packagings must provide information regarding procedures to be followed (including closure instructions for inner packagings and receptacles), a description of the types and dimensions of the closures (including required gaskets) and any other components needed to ensure that packages, as presented for transport, are capable of passing the applicable performance tests of Chapters 4 to 7 and the pressure differential requirements of 4;1.1.6 as applicable.

1.2 CODES FOR DESIGNATING TYPES OF PACKAGINGS

1.2.1 The code consists of:

- an Arabic numeral indicating the kind of packaging, e.g. drum, jerrican, etc., followed by
- a capital letter(s) in Latin characters indicating the nature of the material, e.g. steel, wood, etc., followed where necessary by
- an Arabic numeral indicating the category of packaging within the kind to which the packaging belongs.

1.2.2 In the case of composite packagings, two capital letters in Latin characters are used in sequence in the second position of the code. The first indicates the material of the inner receptacle and the second that of the outer packaging.

1.2.3 For combination packagings, only the code number for the outer packaging is used.

1.2.4 The following numerals must be used for the kinds of packaging:

1. Drum
2. Reserved
3. Jerrican
4. Box
5. Bag
6. Composite packaging.

1.2.5 The following capital letters must be used for the types of material:

- A. Steel (all types and surface treatments)
- B. Aluminium
- C. Natural wood
- D. Plywood
- F. Reconstituted wood
- G. Fibreboard
- H. Plastic material
- L. Textile
- M. Paper, multiwall
- N. Metal (other than steel or aluminium)
- P. Glass, porcelain or stoneware (not used in these Instructions).

Note.— *Plastics materials are taken to include other polymeric materials such as rubber.*

1.2.6 The letters “T” or “U” or “V” or “W” may follow the packaging code. The letter “T” signifies a salvage packaging conforming to the requirements of 4.8. The letter “U” signifies a special packaging conforming to the requirements of 6.5.1.6. The letter “V” signifies a special packaging conforming to the requirements of 4.1.7. The letter “W” signifies that the packaging, although of the same type indicated by the code, is manufactured to a specification different to that in 3.1 and is considered equivalent under the requirements of 1.1.2.

1.3 INDEX OF PACKAGINGS

Table 6-2 contains an index of packagings, other than inner packagings, referred to in Chapters 1 to 4. It lists all the packagings, except inner packagings, specified in the United Nations *Recommendations for the Transport of Dangerous Goods*, and notes those not used in these Instructions for air transport. The index lists the number of the paragraph containing the requirements of those packagings used in these Instructions. The performance tests are specified in Chapter 4. Table 6-3 contains an index of inner packagings and lists the paragraph number containing the requirements together with, where applicable, individual performance tests (e.g. for aerosols). In addition to the listed packagings, intermediate bulk containers are permitted for UN 3077 as shown in Packing Instruction 956.

Table 6-2. Index of packagings other than inner packagings

<i>Kind</i>	<i>Code and, where applicable, category</i>	<i>Paragraph</i>	<i>Maximum capacity (L)</i>	<i>Maximum net mass (kg)</i>
Steel drums	1A1 non-removable head	3.1.1	450	400
	1A2 removable head	3.1.1	450	400
Aluminium drums	1B1 non-removable head	3.1.2	450	400
	1B2 removable head	3.1.2	450	400
Metal (other than steel or aluminium) drums	1N1 non-removable head	3.1.3	450	400
	1N2 removable head	3.1.3	450	400
Steel jerricans	3A1 non-removable head	3.1.4	60	120
	3A2 removable head	3.1.4	60	120
Aluminium jerricans	3B1 non-removable head	3.1.4	60	120
	3B2 removable head	3.1.4	60	120
Plywood drums	1D	3.1.5	250	400
Reserved				
Fibre drums	1G	3.1.6	450	400
Plastic drums and jerricans	1H1 drums, non-removable head	3.1.7	450	400
	1H2 drums, removable head	3.1.7	450	400
	3H1 jerricans, non-removable head	3.1.7	60	120
	3H2 jerricans, removable head	3.1.7	60	120

<i>Kind</i>	<i>Code and, where applicable, category</i>	<i>Paragraph</i>	<i>Maximum capacity (L)</i>	<i>Maximum net mass (kg)</i>
Boxes of natural wood	4C1 ordinary	3.1.8		400
	4C2 with siftproof walls	3.1.8		400
Plywood boxes	4D	3.1.9		400
Reconstituted wood boxes	4F	3.1.10		400
Fibreboard boxes	4G	3.1.11		400
Plastic boxes	4H1 expanded plastic boxes	3.1.12		60
	4H2 solid plastic boxes	3.1.12		400
Steel, aluminium or other metal boxes	4A steel	3.1.13		400
	4B aluminium	3.1.13		400
	4N metal, other than steel or aluminium	3.1.13		400
Textile bags	5L1 without inner liner or coating	Not used in these Instructions		
	5L2 siftproof	3.1.14		50
	5L3 water-resistant	3.1.14		50
Woven plastic bags	5H1 without inner liner or coating	3.1.15	Specialized use only	50
	5H2 siftproof	3.1.15		50
	5H3 water-resistant	3.1.15		50
Plastic film bags	5H4	3.1.16		50
Paper bags	5M1 multiwall	3.1.17		
	5M2 multiwall, water-resistant	3.1.17		50
Composite packaging (plastic material)	6HA1 plastic receptacle with outer steel drum	3.1.18	250	400
	6HA2 plastic receptacle with outer steel crate*/or box	3.1.18	60	75
	6HB1 plastic receptacle with outer aluminium drum	3.1.18	250	400
	6HB2 plastic receptacle with outer aluminium crate*/or box	3.1.18	60	75
	6HC plastic receptacle with outer wooden box	3.1.18	60	75
	6HD1 plastic receptacle with outer plywood drum	3.1.18	250	400
	6HD2 plastic receptacle with outer plywood box	3.1.18	60	75
	6HG1 plastic receptacle with outer fibre drum	3.1.18	250	400
	6HG2 plastic receptacle with outer fibreboard box	3.1.18	60	75
	6HH1 plastic receptacle with outer plastic drum	3.1.18	250	400
6HH2 plastic receptacle with outer solid plastic box	3.1.18	60	75	
Composite packagings (glass, porcelain or stoneware)	6PA1 receptacle with outer steel drum			
	6PA2 receptacle with outer steel crate*/or box			
	6PB1 receptacle with outer aluminium drum			
	6PB2 receptacle with outer aluminium crate*/or box			
	6PC receptacle with outer wooden box			
	6PD1 receptacle with outer plywood drum	Not used in these Instructions		
	6PD2 receptacle with outer wickerwork hamper			
	6PG1 receptacle with outer fibre drum			
	6PG2 receptacle with outer fibreboard box			
	6PH1 receptacle with outer expanded plastic packaging			
6PH2 receptacle with outer solid plastic packaging				

* Crates are outer packagings with incomplete surfaces. For air transport, crates may not be used as outer packagings of composite packagings.

Table 6-3. Index of inner packagings

<i>Code</i>	<i>Kind</i>	<i>Paragraph</i>
	Glass	3.2.1
	Plastic	3.2.2
	Metal cans, tins or tubes	3.2.3
	Paper bags	3.2.4
	Plastic bags	3.2.5
	Fibre cans or boxes	3.2.6
IP.7	Metal receptacles (aerosols), non-refillable	3.2.7.1
IP.7A	Metal receptacles (aerosols), non-refillable	3.2.7.1
IP.7B	Metal receptacles (aerosols), non-refillable	3.2.7.2
IP.7C	Plastic receptacle (aerosols), non-refillable	3.2.8
	Metal or plastic flexible tubes	3.2.9

Chapter 2

MARKING OF PACKAGINGS OTHER THAN INNER PACKAGINGS

Introductory Notes

Note 1.— The marking indicates that the packaging which bears it corresponds to a successfully tested design type and that it complies with the provisions of Chapters 3 and 4 which are related to the manufacture, but not to the use, of the packaging. In itself, therefore, the mark does not necessarily confirm that the packaging may be used for any particular substance.

Note 2.— The marking is intended to be of assistance to packaging manufacturers, reconditioners, packaging users, operators and appropriate authorities. In relation to the use of a new packaging, the original marking is a means for its manufacturer(s) to identify the type and to indicate those performance test regulations that have been met.

Note 3.— The marking does not always provide full details of the test levels, etc., and these may need to be taken further into account, e.g. by reference to a test certificate, test reports or register of successfully tested packagings. For example, a packaging having an X or Y marking may be used for substances to which a packing group having a lesser degree of danger has been assigned with the relevant maximum permissible value of the relative density, determined by taking into account the factor 1.5 or 2.25 indicated in the test requirements for packagings in Chapter 4 as appropriate, i.e. a Packing Group I packaging tested for products with a relative density of 1.2 could be used as a Packing Group II packaging for products with a relative density of 1.8 or a Packing Group III packaging for products with a relative density of 2.7, provided of course that all the performance criteria can still be met with the higher relative density.

2.1 MARKING REQUIREMENTS FOR PACKAGINGS OTHER THAN INNER PACKAGINGS

2.1.1 Each packaging intended for use according to these Instructions must bear markings which are durable, legible and placed in a location and of such a size relative to the packaging as to be readily visible. For packages with a gross mass of more than 30 kg the markings, or a duplicate thereof, must appear on the top or on a side of the packaging. Letters, numerals and symbols must be at least 12 mm high, except for packagings of 30 L or 30 kg capacity or less, when they must be at least 6 mm in height and for packagings of 5 L or 5 kg or less when they must be of an appropriate size. The markings must show:

- a) the United Nations packaging symbol 

This symbol must not be used for any purpose other than certifying that a packaging complies with the relevant requirements in Chapters 1 to 6. For embossed metal packagings the capital letters “UN” may be applied as the symbol;

- b) the code designating the type of packaging according to 1.2;
- c) a code in two parts:
- 1) a letter designating the packing group(s) for which the design type has been successfully tested:
 - X for Packing Groups I, II and III
 - Y for Packing Groups II and III
 - Z for Packing Group III only;
 - 2) A) for single packagings intended to contain liquids: the relative density, rounded off to the first decimal, for which the design type has been tested; this may be omitted when the relative density does not exceed 1.2;
 - B) for packagings intended to contain solids or inner packagings: the maximum gross mass, in kilograms, at which the design type has been tested;
- d) 1) for single packagings intended to contain liquids: the hydraulic test pressure which the packaging was shown to withstand, in kPa rounded down to the nearest 10 kPa;
- 2) for packagings intended to contain solids or inner packagings: the letter “S”;
- e) the last two digits of the year during which the packaging was manufactured. Packagings of types 1H1, 1H2, 3H1 and 3H2 must also be appropriately marked with the month of manufacture; this may be marked on the packaging in a different place from the remainder of the marking. An appropriate method is:

≠

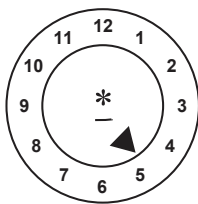

+ * The last two digits of the year of manufacture may be displayed at that place. In such a case, the two digits of the year in the type approval marking and in the inner circle of the clock must be identical.

+ *Note.— Other methods that provide the minimum required information in a durable, visible and legible form are also acceptable.*

f) the State authorizing the allocation of the mark, indicated by the distinguishing sign for motor vehicles in international traffic;

g) the name of the manufacturer or other identification of the packaging specified by the appropriate national authority.

2.1.2 In addition to the durable markings prescribed in 2.1.1, every new metal drum of a capacity greater than 100 L must bear the marks described in 2.1.1 a) to e) on the bottom, with an indication of the nominal thickness of at least the metal used in the body (in mm, to 0.1 mm), in a permanent form (e.g. embossed). When the nominal thickness of either head of a metal drum is thinner than that of the body, the nominal thicknesses of the top head, body and bottom head must be marked on the bottom in a permanent form (e.g. embossed), for example “1.0-1.2-1.0” or “0.9-1.0-1.0”. Nominal thicknesses of metal must be determined according to the appropriate ISO Standard, for example ISO 3574:1999 for steel. The marks indicated in 2.1.1 f) and g) must not be applied in a permanent form (e.g. embossed) except as provided for in 2.1.5.

2.1.3 Every packaging liable to undergo a reconditioning process other than those referred to in 2.1.2 must bear the marks indicated in 2.1.1 a) to e) in a permanent form. Marks are permanent if they are able to withstand the reconditioning process (e.g. embossed). For packagings other than metal drums of a capacity greater than 100 L, these permanent marks may replace the corresponding durable markings prescribed in 2.1.1.

2.1.4 For re-manufactured metal drums, if there is no change to the packaging type and no replacement or removal of integral structural components, the required markings need not be permanent (e.g. embossed). Every other re-manufactured metal drum must bear the markings indicated in 2.1.1 a) to e) in a permanent form (e.g. embossed) on the top head or side.

2.1.5 Metal drums made from materials (e.g. stainless steel) designed to be reused repeatedly may bear the markings indicated in 2.1.1 f) and g) in a permanent form (e.g. embossed).

2.1.6 Packagings manufactured with recycled plastic material as defined in 1;3 must be marked “REC”. This mark must be placed near the marking prescribed in 2.1.1.

2.1.7 Marking must be applied in the sequence of the sub-paragraphs in 2.1.1; each element of the marking required in these sub-paragraphs and when appropriate sub-paragraphs h) to j) of 2.1.8 must be clearly separated, e.g. by a slash or space, so as to be easily identified; for examples see 2.1.10; 2.2.3; and 2.3. Any additional markings authorized by the appropriate national authority must still enable the parts of the marking to be correctly identified with reference to 2.1.1.

2.1.8 After reconditioning a packaging, the reconditioner must apply to it, in sequence, a durable marking showing:

h) the State in which the reconditioning was carried out, indicated by the distinguishing sign for motor vehicles in international traffic;

i) the name of the reconditioner or other identification of the packaging specified by the appropriate national authority;

j) the year of reconditioning; the letter “R”; and for every packaging successfully passing the leakproofness test in 4.4, the additional letter “L”.

2.1.9 When, after reconditioning, the markings required by 2.1.1 a) to d) no longer appear on the top head or the side of a metal drum, the reconditioner must apply them in a durable form followed by those required by 2.1.8. The markings must not identify a greater performance capability than that for which the original design type had been tested and marked.

2.1.10 Examples of markings for NEW packagings:

for a new fibreboard box



4G/Y145/S/02
NL/VL823

as in 2.1.1 a), b), c)1), c)2)B), d)2) and e)
as in 2.1.1 f) and g)

for a new steel drum to contain liquids

 1A1/Y1.4/150/98 as in 2.1.1 a), b), c)1), c)2)A), d)1) and e)
NL/VL824 as in 2.1.1 f) and g)

for a new steel drum to contain solids, or inner packagings

 1A2/Y150/S/01 as in 2.1.1 a), b), c)1), c)2)B), d)2) and e)
NL/VL825 as in 2.1.1 f) and g)

for a new plastic box of equivalent specification

 4HW/Y136/S/98 as in 2.1.1 a), b), c)1), c)2)B), d)2) and e)
NL/VL826 as in 2.1.1 f) and g)

for a remanufactured steel drum to contain liquids

 1A2/Y/100/01 as in 2.1.1 a), b), c)1), c)2)A), d)1) and e)
USA/MM5 as in 2.1.1 f) and g)

2.1.11 Examples of markings for RECONDITIONED packagings:

 1A1/Y1.4/150/97 as in 2.1.1 a), b), c)1), c)2)A), d)1) and e)
NL/RB/01 RL as in 2.1.8 h), i) and j)

 1A2/Y150/S/99 as in 2.1.1 a), b), c)1), c)2)B), d)2) and e)
USA/RB/00 R as in 2.1.8 h), i) and j)

2.2 PACKAGING MARKINGS FOR INFECTIOUS SUBSTANCES

2.2.1 Packagings for infectious substances, which meet the requirements of Packing Instruction 620 and Chapter 6 of this Part, must be marked with a packaging marking.

2.2.2 The packaging marking consists of:

- the United Nations packaging symbol;
- the code designating the type of packaging according to the provisions of 1.3;
- the text "CLASS 6.2";
- the last two digits of the year of manufacture of the packaging;
- the State authorizing the allocation of the mark, indicated by the distinguishing sign for motor vehicles in international traffic;
- the name of the manufacturer or other identification of the packaging specified by the appropriate national authority.

2.2.3 Example of a marking is:

 4G/CLASS 6.2/01 as in 2.2.2 a), b), c) and d)
S/SP-9989-ERIKSSON as in 2.2.2 e) and f)

Each element of the marking applied in accordance with a) to f) must be clearly separated, e.g. by a slash or space, so as to be easily identifiable.

2.3 PACKAGING MARKINGS FOR SALVAGE PACKAGINGS

Example of marking for SALVAGE packagings:

 1A2T/Y300/S/01 as in 2.1.1 a), b), c)2)B), d)2) and e)
USA/abc as in 2.1.1 f) and g)

Note.— In the examples given in 2.1.10, 2.2.3 and 2.3, the markings are shown, for convenience, in two lines; however, the markings can be applied in a single line or in multiple lines provided they are given in the correct sequence. Additionally, the inclusion in the specification marking of the "r" symbol is optional.

2.4 PACKAGING MARKINGS FOR INTERMEDIATE BULK CONTAINERS

2.4.1 Intermediate bulk containers, which meet the requirements of Chapter 6.5 of the UN Recommendations, must be marked with a packaging marking.

2.4.2 The packaging marking consists of:

- a) the United Nations packaging symbol 

For metal IBCs on which the marking is stamped or embossed, the capital letters "UN" may be applied instead of the symbol;

- b) The code designating the type of IBC as shown in Packing Instruction 956 and as described in detail in Chapter 6.5 of the UN Model Recommendations;
- c) A capital letter designating the packing group(s) for which the design type has been approved:
- 1) X for Packing Groups I, II and III;
 - 2) Y for Packing Groups II and III;
 - 3) Z for Packing Group III only;
- d) The month and year (last two digits) of manufacture;
- e) The State authorizing the allocation of the mark; indicated by the distinguishing sign for motor vehicles in international traffic;
- f) The name or symbol of the manufacturer and other identification of the IBC, as specified by the appropriate national authority;
- g) The stacking test load in kg. For IBCs not designed for stacking, the figure "0" must be shown;
- h) The maximum permissible gross mass in kg.

≠ 2.4.3 The maximum permitted stacking load applicable when the IBC is in use must be displayed on a symbol as shown in Figure 6-1 or Figure 6-2. The symbol must be durable and clearly visible.

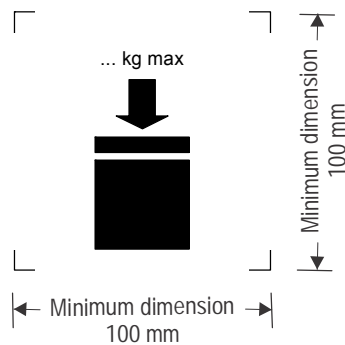

≠ **Figure 6-1. IBCs capable of being stacked**

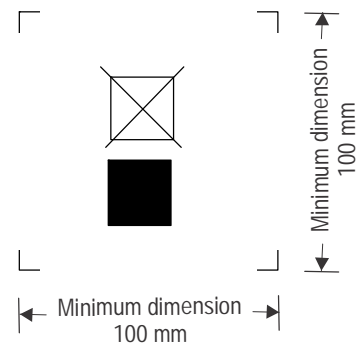

Figure 6-2. IBCs not capable of being stacked

≠ The minimum dimensions must be 100 mm x 100 mm. The letters and numbers indicating the mass must be at least 12 mm high. The area within the printer's marks indicated by the dimensional arrows must be square. Where dimensions are not specified, all features must be in approximate proportion to those shown. The mass marked above the symbol must not exceed the load imposed during the design type test (see 6.5.6.6.4 of the UN Model Regulations) divided by 1.8.

+ *Note.— The provisions of 2.4.3 must apply to all IBCs manufactured, repaired or remanufactured as from 1 January 2011. The provisions of 2.4.3 of the 2013-2014 Edition of these Instructions may continue to be applied to all IBCs manufactured, repaired or remanufactured between 1 January 2011 and 31 December 2016.*

2.4.4 Example of a marking is:

 13H3/Z/03 01 as in as in 2.4.2 a), b),c), and d)
F/Meunier1713/0/1000 as in 2.4.2 e), f), g) and h)

Chapter 3

REQUIREMENTS FOR PACKAGINGS

3.1 REQUIREMENTS FOR PACKAGINGS OTHER THAN INNER PACKAGINGS

GENERAL REQUIREMENTS

Any permeation of the substance contained in the packaging must not constitute a danger under normal conditions of transport.

3.1.1 Steel drums

1A1 non-removable head

1A2 removable head

3.1.1.1 Body and heads must be constructed of steel sheet of a suitable type and of adequate thickness in relation to the capacity of the drum and to its intended use.

Note.— In the case of carbon steel drums, “suitable” steels are identified in ISO 3573:1999 “Hot rolled carbon steel sheet of commercial and drawing qualities” and ISO 3574:1999 “Cold-reduced carbon steel of commercial and drawing qualities”. For carbon steel drums below 100 litres, “suitable” steels in addition to the above standards are also identified in ISO 11949:1995 “Cold-reduced electrolytic tinplate”, ISO 11950:1995 “Cold-reduced electrolytic chromium/chromium oxide-coated steel” and ISO 11951:1995 “Cold-reduced blackplate in coil form for the production of tinplate or electrolytic chromium/chromium oxide-coated steel”.

3.1.1.2 Body seams must be welded on drums intended to contain more than 40 L of liquids. Body seams must be mechanically seamed or welded on drums intended to contain solids, or 40 L or less of liquids.

3.1.1.3 Chimes must be mechanically seamed or welded. Separate reinforcing rings may be applied.

3.1.1.4 The body of a drum of a capacity greater than 60 L must, in general, have at least two expanded rolling hoops or, alternatively, at least two separate rolling hoops. If there are separate rolling hoops they must be fitted tightly on the body and so secured that they cannot shift. Rolling hoops must not be spot welded.

3.1.1.5 Openings for filling, emptying and venting in the bodies or heads of non-removable head (1A1) drums must not exceed 7 cm in diameter. Drums with larger openings are considered to be of the removable head type (1A2). Closures for openings in the bodies and heads of drums must be so designed and applied that they will remain secure and leakproof under normal conditions of transport. Closure flanges may be mechanically seamed or welded in place. Gaskets or other sealing elements must be used with closures, unless the closure is inherently leakproof.

3.1.1.6 Closure devices for removable head drums must be so designed and applied that they will remain secure and drums will remain leakproof under normal conditions of transport. Gaskets or other sealing elements must be used with all removable heads.

3.1.1.7 If materials used for body, heads, closures and fittings are not in themselves compatible with the contents to be transported, suitable internal protective coatings or treatments must be applied. These coatings or treatments must retain their protective properties under normal conditions of transport.

3.1.1.8 Maximum capacity of drum: 450 L.

3.1.1.9 Maximum net mass: 400 kg.

3.1.2 Aluminium drums

1B1 non-removable head

1B2 removable head

3.1.2.1 Body and heads must be constructed of aluminium at least 99 per cent pure or of an aluminium base alloy. Materials must be of a suitable type and of adequate thickness in relation to the capacity of the drum and to its intended use.

3.1.2.2 All seams must be welded. Chime seams, if any, must be reinforced by the application of separate reinforcing rings.

3.1.2.3 The body of a drum of a capacity greater than 60 L must, in general, have at least two expanded rolling hoops or, alternatively, at least two separate rolling hoops. If there are separate rolling hoops they must be fitted tightly on the body and so secured that they cannot shift. Rolling hoops must not be spot welded.

3.1.2.4 Openings for filling, emptying and venting in the bodies or heads on non-removable head (1B1) drums must not exceed 7 cm in diameter. Drums with larger openings are considered to be of the removable head type (1B2). Closures for openings in the bodies and heads of drums must be so designed and applied that they will remain secure and leakproof under normal conditions of transport. Closure flanges must be welded in place so that the weld provides a leakproof seam. Gaskets or other sealing elements must be used with closures, unless the closure is inherently leakproof.

3.1.2.5 Closure devices for removable head drums must be so designed and applied that they will remain secure and drums will remain leakproof under normal conditions of transport. Gaskets or other sealing elements must be used with all removable heads.

3.1.2.6 Maximum capacity of drum: 450 L.

3.1.2.7 Maximum net mass: 400 kg.

3.1.3 Drums of metal other than aluminium or steel

1N1 non-removable head

1N2 removable head

3.1.3.1 The body and heads must be constructed of a metal or of a metal alloy other than steel or aluminium. Material must be of a suitable type and of adequate thickness in relation to the capacity of the drum and to its intended use.

3.1.3.2 Chime seams, if any, must be reinforced by the application of separate reinforcing rings. All seams, if any, must be joined (welded, soldered, etc.) in accordance with the technical state-of-the-art for the metal or metal alloy used.

3.1.3.3 The body of a drum of a capacity greater than 60 L must, in general, have at least two expanded rolling hoops or, alternatively, at least two separate rolling hoops. If there are separate rolling hoops, they must be fitted tightly on the body and so secured that they cannot shift. Rolling hoops must not be spot welded.

3.1.3.4 Openings for filling, emptying and venting in the bodies or heads on non-removable head (1N1) drums must not exceed 7 cm in diameter. Drums with larger openings are considered to be of the removable head type (1N2). Closures for openings in the bodies and heads of drums must be so designed and applied that they will remain secure and leakproof under normal conditions of transport. Closure flanges must be joined in place (welded, soldered, etc.) in accordance with the technical state of the art for the metal or metal alloy used so that the seam join is leakproof. Gaskets or other sealing elements must be used with closures, unless the closure is inherently leakproof.

3.1.3.5 Closure devices for removable head drums must be so designed and applied that they will remain secure and drums will remain leakproof under normal conditions of transport. Gaskets or other sealing elements must be used with all removable heads.

3.1.3.6 Maximum capacity of drum: 450 L.

3.1.3.7 Maximum net mass: 400 kg.

3.1.4 Steel or aluminium jerricans

3A1 steel, non-removable head

3A2 steel, removable head

3B1 aluminium, non-removable head

3B2 aluminium, removable head

3.1.4.1 Body and heads must be constructed of a steel sheet of aluminium at least 99 per cent pure or of an aluminium base alloy. Material must be of a suitable type and of adequate thickness in relation to the capacity of the jerrican and to its intended use.

3.1.4.2 Chimes of steel jerricans must be mechanically seamed or welded. Body seams of steel jerricans intended to contain more than 40 L of liquid must be welded. Body seams of steel jerricans intended to contain 40 L or less must be mechanically seamed or welded. For aluminium jerricans, all seams must be welded. Chime seams, if any, must be reinforced by the application of a separate reinforcing ring.

3.1.4.3 Openings in jerricans (3A1 and 3B1) must not exceed 7 cm in diameter. Jerricans with larger openings are considered to be of the removable head type (3A2 and 3B2). Closures must be so designed that they will remain secure and leakproof under normal conditions of transport. Gaskets or other sealing elements must be used with closures, unless the closure is inherently leakproof.

3.1.4.4 If materials used for body, heads, closures and fittings are not in themselves compatible with the contents to be transported, suitable internal protective coatings or treatments must be applied. These coatings or treatments must retain their protective properties under normal conditions of transport.

3.1.4.5 Maximum capacity of jerrican: 60 L.

3.1.4.6 Maximum net mass: 120 kg.

3.1.5 Plywood drums

1D

3.1.5.1 The wood used must be well seasoned, commercially dry and free from any defect likely to lessen the effectiveness of the drum for the purpose intended. If a material other than plywood is used for the manufacture of the heads, it must be of a quality equivalent to the plywood.

3.1.5.2 At least two-ply plywood must be used for the body and at least three-ply plywood for the heads; the plies must be firmly glued together by a water-resistant adhesive with their grain crosswise.

3.1.5.3 The body and heads of the drum and their joints must be of a design appropriate to the capacity of the drum and to its intended use.

3.1.5.4 In order to prevent sifting of the contents, lids must be lined with kraft paper or some other equivalent material which must be securely fastened to the lid and extend to the outside along its full circumference.

3.1.5.5 Maximum capacity of drum: 250 L.

3.1.5.6 Maximum net mass: 400 kg.

3.1.6 Fibre drums

1G

3.1.6.1 The body of the drum must consist of multiple plies of heavy paper or fibreboard (without corrugations) firmly glued or laminated together and may include one or more protective layers of bitumen, waxed kraft paper, metal foil, plastic material, etc.

3.1.6.2 Heads must be of natural wood, fibreboard, metal, plywood, plastic or other suitable material and may include one or more protective layers of bitumen, waxed kraft paper, metal foil, plastic material, etc.

3.1.6.3 The body and heads of the drum and their joints must be of a design appropriate to the capacity of the drum and to its intended use.

3.1.6.4 The assembled packaging must be sufficiently water-resistant so as not to delaminate under normal conditions of transport.

3.1.6.5 Maximum capacity of drum: 450 L.

3.1.6.6 Maximum net mass: 400 kg.

3.1.7 Plastic drums and jerricans

1H1 drums, non-removable head

1H2 drums, removable head

3H1 jerricans, non-removable head

3H2 jerricans, removable head

3.1.7.1 The packaging must be manufactured from suitable plastic material and be of adequate strength in relation to its capacity and intended use. Except for recycled plastic material as defined in 1;3, no used material other than production residues or regrind from the same manufacturing process may be used. The packaging must be adequately resistant to aging and to degradation caused either by the substance contained or by ultraviolet radiation. Any permeation of the substance contained must not constitute a danger under normal conditions of transport.

3.1.7.2 If protection against ultraviolet radiation is required, it must be provided by the addition of carbon black or other suitable pigments or inhibitors. These additives must be compatible with the contents and remain effective throughout the life of the packaging. Where use is made of carbon black, pigments or inhibitors other than those used in the manufacture of the tested design type, retesting may be waived if the carbon black content does not exceed 2 per cent by mass or if the pigment content does not exceed 3 per cent by mass; the content of inhibitors of ultraviolet radiation is not limited.

3.1.7.3 Additives serving purposes other than protection against ultraviolet radiation may be included in the composition of the plastic material provided that they do not adversely affect the chemical and physical properties of the material of the packaging. In such circumstances retesting may be waived.

3.1.7.4 The wall thickness at every point of the packaging must be appropriate to its capacity and intended use, taking into account the stresses to which each point is liable to be exposed.

3.1.7.5 Openings for filling, emptying and venting in the bodies or heads of non-removable head drums (1H1) and jerricans (3H1) must not exceed 7 cm in diameter. Drums and jerricans with larger openings are considered to be of the removable head type (1H2 and 3H2). Closures for openings in the bodies or heads of drums and jerricans must be so designed and applied that they will remain secure and leakproof under normal conditions of transport. Gaskets or other sealing elements must be used with closures unless the closure is inherently leakproof.

3.1.7.6 Closure devices for removable head drums and jerricans must be so designed and applied that they will remain secure and leakproof under normal conditions of transport. Gaskets must be used with all removable heads unless the drum or jerrican design is such that, where the removable head is properly secured, the drum or jerrican is inherently leakproof.

3.1.7.7 Maximum capacity of drums and jerricans:

1H1, 1H2: 450 L;
3H1, 3H2: 60 L.

3.1.7.8 Maximum net mass:

1H1, 1H2: 400 kg;
3H1, 3H2: 120 kg.

3.1.8 Boxes of natural wood

4C1 ordinary
4C2 with siftproof walls

3.1.8.1 The wood used must be well seasoned, commercially dry and free from defects that would materially lessen the strength of any part of the box. The strength of the material used and the method of construction must be appropriate to the capacity and intended use of the box. The tops and bottoms may be made of water-resistant reconstituted wood such as hardboard, particle board or other suitable type.

3.1.8.2 Fastenings must be resistant to vibration experienced under normal conditions of transport. End grain nailing must be avoided whenever practicable. Joins which are likely to be highly stressed must be made using clenched or annular ring nails or equivalent fastenings.

3.1.8.3 Box 4C2: each part must consist of one piece or be equivalent thereto. Parts are considered equivalent to one piece when one of the following methods of glued assembly is used: Lindermann joint, tongue and groove joint, ship lap or rabbet joint or butt joint with at least two corrugated metal fasteners at each joint.

3.1.8.4 Maximum net mass: 400 kg.

3.1.9 Plywood boxes

4D

3.1.9.1 Plywood used must be at least 3-ply. It must be made from well seasoned rotary cut, sliced or sawn veneer, commercially dry and free from defects that would materially lessen the strength of the box. The strength of the material used and the method of construction must be appropriate to the capacity and intended use of the box. All adjacent plies must be glued with water-resistant adhesive. Other suitable materials may be used together with plywood in the construction of boxes. Boxes must be firmly nailed or screwed to corner posts or ends or be assembled by equally suitable devices.

3.1.9.2 Maximum net mass: 400 kg.

3.1.10 Reconstituted wood boxes

4F

3.1.10.1 The walls of boxes must be made of water-resistant reconstituted wood such as hardboard, particle board or other suitable type. The strength of the material used and the method of construction must be appropriate to the capacity of the boxes and their intended use.

3.1.10.2 Other parts of the boxes may be made of other suitable material.

3.1.10.3 Boxes must be securely assembled by means of suitable devices.

3.1.10.4 Maximum net mass: 400 kg.

3.1.11 Fibreboard boxes

4G

3.1.11.1 Strong and good quality solid or double-faced corrugated fibreboard (single or multiwall) must be used, appropriate to the capacity of the box and to its intended use. The water resistance of the outer surface must be such that the

increase in mass, as determined in a test carried out over a period of 30 minutes by the Cobb method of determining water absorption, is not greater than 155 g/m^2 — see ISO 535:1991. It must have proper bending qualities. Fibreboard must be cut, creased without scoring, and slotted so as to permit assembly without cracking, surface breaks or undue bending. The fluting of corrugated fibreboard must be firmly glued to the facings.

3.1.11.2 The ends of boxes may have a wooden frame or be entirely of wood or other suitable material. Reinforcements of wooden battens or other suitable material may be used.

3.1.11.3 Manufacturing joins in the body of boxes must be taped, lapped and glued or lapped and stitched with metal staples. Lapped joins must have an appropriate overlap.

3.1.11.4 Where closing is effected by gluing or taping, a water-resistant adhesive must be used.

3.1.11.5 Boxes must be designed so as to provide a good fit to the contents.

3.1.11.6 Maximum net mass: 400 kg.

3.1.12 Plastic boxes

4H1 expanded plastic boxes

4H2 solid plastic boxes

3.1.12.1 The box must be manufactured from suitable plastic material and be of adequate strength in relation to its capacity and intended use. The box must be adequately resistant to aging and to degradation caused either by the substance contained or by ultraviolet radiation.

3.1.12.2 An expanded plastic box must comprise two parts made of a moulded expanded plastic material, a bottom section containing cavities for the inner packagings and a top section covering and interlocking with the bottom section. The top and bottom sections must be designed so that the inner packagings fit snugly. The closure cap for any inner packaging must not be in contact with the inside of the top section of this box.

3.1.12.3 For dispatch, an expanded plastic box must be closed with a self-adhesive tape having sufficient tensile strength to prevent the box from opening. The adhesive tape must be weather-resistant and its adhesive compatible with the expanded plastic material of the box. Other closing devices at least equally effective may be used.

3.1.12.4 For solid plastic boxes, protection against ultraviolet radiation, if required, must be provided by the addition of carbon black or other suitable pigments or inhibitors. These additives must be compatible with the contents and remain effective throughout the life of the box. Where use is made of carbon black, pigments or inhibitors other than those used in the manufacture of the tested design type, re-testing may be waived if the carbon black content does not exceed 2 per cent by mass or if the pigment content does not exceed 3 per cent by mass; the content of inhibitors of ultraviolet radiation is not limited.

3.1.12.5 Additives serving purposes other than protection against ultraviolet radiation may be included in the composition of the plastic material provided that they do not adversely affect the chemical or physical properties of the material of the box. Under such circumstances re-testing may be waived.

3.1.12.6 Solid plastic boxes must have closure devices made of a suitable material, of adequate strength and so designed as to prevent the box from unintentional opening.

3.1.12.7 Maximum net mass:

4H1 box: 60 kg;

4H2 box: 400 kg.

3.1.13 Steel, aluminium or other metal boxes

4A steel

4B aluminium

4N metal, other than steel or aluminium

3.1.13.1 The strength of the metal and the construction of the box must be appropriate to the capacity of the box and to its intended use.

3.1.13.2 Boxes must be lined with fibreboard or felt packing pieces or must have an inner liner or coating of suitable material as required. If a double seamed metal liner is used, steps must be taken to prevent the ingress of substances, particularly explosives, into the recesses of the seams.

3.1.13.3 Closures may be of any suitable type; they must remain secured under normal conditions of transport.

3.1.13.4 Maximum net mass: 400 kg.

3.1.14 Textile bags

5L2 siftproof

5L3 water-resistant

3.1.14.1 The textiles used must be of good quality. The strength of the fabric and the construction of the bag must be appropriate to the capacity of the bag and to its intended use.

3.1.14.2 Bags, siftproof, 5L2: the bag must be made siftproof, for example by the use of:

- paper bonded to the inner surface of the bag by a water-resistant adhesive such as bitumen; or
- plastic film bonded to the inner surface of the bag; or
- one or more inner liners made of paper or plastic material.

3.1.14.3 Bags, water-resistant, 5L3: to prevent the entry of moisture the bag must be made waterproof, for example by the use of:

- separate inner liners of water-resistant paper (e.g. waxed kraft paper, tarred paper or plastic-coated kraft paper); or
- plastic film bonded to the inner surface of the bag; or
- one or more inner liners made of plastic material.

3.1.14.4 Maximum net mass: 50 kg.

3.1.15 Woven plastic bags

5H1 without inner lining or coating

5H2 siftproof

5H3 water-resistant

3.1.15.1 Bags must be made from stretched tapes or monofilaments of a suitable plastic material. The strength of the material used and the construction of the bag must be appropriate to the capacity of the bag and to its intended use.

3.1.15.2 If the fabric is woven flat, the bags must be made by sewing or some other method ensuring closure of the bottom and one side. If the fabric is tubular, the bag must be closed by sewing, weaving or some other equally strong method of closure.

3.1.15.3 Bags, siftproof, 5H2: The bag must be made siftproof, for example by means of:

- paper or a plastic film bonded to the inner surface of the bag; or
- one or more separate inner liners made of paper or plastic material.

3.1.15.4 Bags, water-resistant, 5H3: To prevent the entry of moisture, the bag must be made waterproof, for example by means of:

- separate inner liners of water-resistant paper (e.g. waxed kraft paper, double-tarred kraft paper or plastic-coated kraft paper); or
- plastic film bonded to the inner or outer surface of the bag; or
- one or more inner plastic liners.

3.1.15.5 Maximum net mass: 50 kg.

3.1.16 Plastic film bags

5H4

3.1.16.1 Bags must be made of a suitable plastic material. The strength of the material used and the construction of the bag must be appropriate to the capacity of the bag and to its intended use. Joins and closures must withstand pressures and impacts liable to occur under normal conditions of transport.

3.1.16.2 Maximum net mass: 50 kg.

3.1.17 Paper bags

5M1 multiwall
5M2 multiwall, water-resistant

3.1.17.1 Bags must be made of a suitable kraft paper or of an equivalent paper with at least three plies, the middle ply of which may be net-cloth and adhesive bonding to the outer paper plies. The strength of the paper and the construction of the bags must be appropriate to the capacity of the bag and to its intended use. Joins and closures must be siftproof.

3.1.17.2 To prevent the entry of moisture, a bag of four plies or more must be made waterproof by the use of either a water-resistant ply as one of the two outermost plies or a water-resistant barrier made of a suitable protective material between the two outermost plies. A bag of three plies must be made waterproof by the use of a water-resistant ply as the outermost ply. Where there is a danger of the substance contained reacting with moisture or where it is packed damp, a waterproof ply or barrier, such as double-tarred kraft paper, plastic-coated kraft paper, plastic film bonded to the inner surface of the bag, or one or more inner plastic liners, must also be placed next to the substance. Joins and closures must be waterproof.

3.1.17.3 Maximum net mass: 50 kg.

3.1.18 Composite packagings (plastic material)

6HA1 plastic receptacle with outer steel drum
6HA2 plastic receptacle with outer steel crate*/or box
6HB1 plastic receptacle with outer aluminium drum
6HB2 plastic receptacle with outer aluminium crate*/or box
6HC plastic receptacle with outer wooden box
6HD1 plastic receptacle with outer plywood drum
6HD2 plastic receptacle with outer plywood box
6HG1 plastic receptacle with outer fibre drum
6HG2 plastic receptacle with outer fibreboard box
6HH1 plastic receptacle with outer plastic drum
6HH2 plastic receptacle with outer solid plastic box

3.1.18.1 Inner receptacle

3.1.18.1.1 The provisions of 3.1.7.1 and 3.1.7.3 to 3.1.7.6 apply to inner plastic receptacles.

3.1.18.1.2 The inner plastic receptacle must fit snugly inside the outer packaging, which must be free of any projection that might abrade the plastic material.

3.1.18.1.3 Maximum capacity of inner receptacles:

6HA1, 6HB1, 6HD1, 6HG1, 6HH1: 250 L;
6HA2, 6HB2, 6HC, 6HD2, 6HG2, 6HH2: 60 L.

3.1.18.1.4 Maximum net mass:

6HA1, 6HB1, 6HD1, 6HG1, 6HH1: 400 kg;
6HA2, 6HB2, 6HC, 6HD2, 6HG2, 6HH2: 75 kg.

3.1.18.2 Outer packaging

3.1.18.2.1 Plastic receptacle with outer steel or aluminium drum 6HA1 or 6HB1; the relevant provisions of 3.1.1 or 3.1.2, as appropriate, apply to the construction of the outer packaging.

3.1.18.2.2 Plastic receptacle with outer steel or aluminium box 6HA2 or 6HB2; the relevant provisions of 3.1.13 apply to the construction of the outer packaging.

3.1.18.2.3 Plastic receptacle with outer wooden box 6HC; the relevant provisions of 3.1.8 apply to the construction of the outer packaging.

3.1.18.2.4 Plastic receptacle with outer plywood drum 6HD1; the relevant provisions of 3.1.5 apply to the construction of the outer packaging.

3.1.18.2.5 Plastic receptacle with outer plywood box 6HD2; the relevant provisions of 3.1.9 apply to the construction of the outer packaging.

3.1.18.2.6 Plastic receptacle with outer fibre drum 6HG1; the provisions of 3.1.6.1 to 3.1.6.4 apply to the construction of the outer packaging.

* Crates are outer packagings with incomplete surfaces. For air transport, crates may not be used as outer packagings of composite packagings.

3.1.18.2.7 Plastic receptacle with outer fibreboard box 6HG2; the relevant provisions of 3.1.11 apply to the construction of the outer packaging.

3.1.18.2.8 Plastic receptacle with outer plastic drum 6HH1; the provisions of 3.1.7.1 and 3.1.7.3 to 3.1.7.7 apply to the construction of the outer packaging.

3.1.18.2.9 Plastic receptacle with outer solid plastic box (including corrugated plastic material) 6HH2; the provisions of 3.1.12.1 and 3.1.12.4 to 3.1.12.6 apply to the construction of the outer packaging.

3.2 REQUIREMENTS FOR INNER PACKAGINGS

3.2.1 Glass

Packagings must be well constructed. The materials of which these packagings and closures are made must be of good quality and, where in contact with the substance or article, not liable to react with it. Closures must be sufficiently tight to prevent leaking and sifting. Stoppers or corks must be held securely in position with wire, adhesive tape, or other positive means. Packagings having necks with moulded screw-threads must have threaded-type caps having a resilient liner completely resistant to the contents.

Glass ampoules must be heat-sealed, gas- and liquid-tight and they must not react chemically when coming into contact with the contents. If glass tubes are also permitted by the appropriate national authority for liquefied gases, they must be thick-walled and free of defects.

3.2.2 Plastic

Packagings must be well constructed. The materials of which these packagings and closures are made must be of good quality polyethylene or other suitable plastic and, where in contact with the substance, resistant to it. Closures must be sufficiently tight to prevent leaking and sifting. Stoppers or corks must be held securely in position with wire, adhesive tape, or other positive means.

3.2.3 Metal cans, tins or tubes

Packagings must be well constructed. The materials of which the packagings and closures are made must be of good quality and, where in contact with the substance, not liable to react with it. Closures must be sufficiently tight to prevent leaking and sifting and threaded-type caps must be equipped with a resilient liner completely resistant to the contents of the packagings.

3.2.4 Paper bags

Shipping sack kraft paper, or equivalent, of at least two sheets of paper must be used.

3.2.5 Plastic bags

The weld-seams and closures of such bags must be siftproof. Plastic bags must have a minimum thickness of 0.1 mm.

3.2.6 Fibre cans or boxes

Packagings must be well constructed and the material of which they are made must be of good quality. Metal tops, bottoms and connections, of suitable thickness, are authorized.

3.2.7 Metal receptacles (aerosols), non-refillable (IP.7, IP.7A, IP.7B)

3.2.7.1 Receptacles (aerosols) IP.7 and IP.7A

3.2.7.1.1 *Materials and construction.* Uniform quality steel plate or non-ferrous metal of uniform drawing quality must be used:

- IP.7 receptacles must have a minimum wall thickness of 0.18 mm;
- IP.7A receptacles must have a minimum wall thickness of 0.20 mm.

The receptacles may be seamless or with seams welded, soldered, brazed, double-seamed or swaged. The ends must be of pressure design. Maximum capacity must not exceed 820 mL and the maximum inner diameter must not exceed 76 mm.

3.2.7.1.2 *Performance test.* One out of each lot of 25 000 or less receptacles successively produced per day must be pressure-tested to destruction:

- IP.7 receptacles must not burst below 1 650 kPa gauge pressure;
- IP.7A receptacles must not burst below 1 860 kPa gauge pressure.

3.2.7.2 *Receptacles (aerosols) IP.7B*

3.2.7.2.1 *Materials and construction.* Uniform quality steel plate or non-ferrous metal of uniform drawing quality must be used. The receptacles may be seamless or with seams welded, soldered, brazed, double-seamed or swaged. The ends must be of pressure design. Maximum capacity must not exceed 1 000 mL and the maximum inner diameter must not exceed 76 mm. The aerosol, including its valve, must be virtually hermetically sealed under normal conditions of transport and the valve must be suitably protected to prevent actuation during transport.

3.2.7.2.2 Performance tests required:

- hydraulic pressure test;
- bursting test;
- leakage test.

3.2.7.2.3 *Hydraulic pressure test.* Number of samples: six receptacles.

Method of testing and pressure applied: the pressure must be applied slowly. The test pressure must be 50 per cent higher than the internal pressure at 50°C but at least 1 000 kPa. The test pressure must be applied for 25 seconds.

Criteria for passing the test successfully: the receptacle must not show major distortions, leaks or similar faults, but a slight symmetrical distortion of the base, or one affecting the profile of the top end shall be allowed, provided that the receptacle passes the bursting test.

3.2.7.2.4 *Bursting test.* Number of samples: six receptacles; these may be the same receptacles used in the hydraulic pressure test.

Method of testing and pressures applied: a hydraulic pressure at least 20 per cent higher than the test pressure as mentioned in 3.2.7.2.3 must be applied.

Criteria for passing the test successfully: no receptacle may leak.

3.2.7.2.5 *Leakage test.* Number of samples: every aerosol.

Method of testing: each aerosol must be immersed in a bath of water. The temperature of the water and the duration of the test must be such that the internal pressure reaches that which would be reached at 55°C, or 50°C if the liquid phase does not exceed 95 per cent of the capacity of the aerosol at 50°C. When an aerosol is sensitive to heat, the temperature of the bath may be set at between 20°C and 30°C in which case one receptacle in 2 000 must be tested at the higher temperature.

Equally effective methods of testing may also be used.

Criteria for passing the test successfully: the aerosol must not show visible permanent distortions or any leakage.

3.2.8 Plastic receptacles (aerosols) non-refillable (IP.7C)

3.2.8.1 *Receptacles (aerosols) IP.7C*

3.2.8.1.1 *Materials and construction.* The receptacle must be of polyethylene terephthalate (PET), polyethylene naphthalate (PEN), polyamide (Nylon), or a blend containing some combination of PET, PEN, ethyl vinyl alcohol (EVOH) and Nylon. Thermoplastic processes ensuring uniformity of the completed container shall be applied. No used material other than production residues or re-grind from the same manufacturing process may be used. The packaging shall be adequately resistant to aging and to degradation caused either by the substance contained or by ultraviolet radiation. Maximum capacity must not exceed 500 mL.

3.2.8.1.2 Performance tests required:

- drop test;
- hydraulic pressure test;
- bursting test;
- leakage test.

3.2.8.1.3 *Drop test.* Method of testing: to ensure that creep does not affect the ability of the receptacle type to retain the contents the receptacles shall be dropped as follows: three groups of twenty-five filled receptacles shall be dropped from 1.8 m on to a rigid, non-resilient, flat and horizontal surface. One group must be conditioned at 38°C for 26 weeks, the second group for 100 hours at 50°C and the third group for 18 hours at 55°C, prior to the drop test.

Criteria for passing the test successfully: the receptacle must not break or leak.

3.2.8.1.4 *Hydraulic pressure test.* Number of samples: six receptacles.

Method of testing: receptacles must resist a test pressure equal to at least 1 200 kPa.

Criteria for passing the test successfully: the receptacle must not show major distortions, leaks or similar faults, but a slight symmetrical distortion of the base, or one affecting the profile of the top end, shall be allowed, provided that the receptacle passes the bursting test.

3.2.8.1.5 *Bursting test.* Number of samples: six. These may be the same receptacles used in the hydraulic pressure test.

Method of testing and pressures applied: a hydraulic pressure at least 20 per cent higher than the test pressure as mentioned in 3.2.8.1.4 must be applied.

Criteria for passing the test successfully: the receptacle must not leak.

3.2.8.1.6 *Leakage test.* Every aerosol. A leakage test in accordance with 6;5.4.1.2 or 6;5.4.3 approved by the competent authority must be used.

3.2.9 Metal or plastic flexible tubes

The materials of construction of flexible tubes and their closures must, where in contact with the organic peroxide, not affect the thermal stability.

Chapter 4

PACKAGING PERFORMANCE TESTS

Introductory Notes

Note 1.— The performance tests specified in this Chapter take account of the material used, and constructional design of packagings. They also take into account whether the goods to be transported are liquid or solid.

Note 2.— The performance tests are designed to ensure that there will be no loss of contents under normal transport conditions. The severity of the tests on a packaging is dependent on the intended contents, taking account of the degree of danger (i.e. packing group), relative density and vapour pressure (for liquids).

4.1 PERFORMANCE AND FREQUENCY OF TESTS

4.1.1 The design type of each packaging must be tested as provided for in this Chapter in accordance with procedures established by the appropriate national authority.

4.1.2 Each packaging design type must successfully pass the tests prescribed in this chapter before being used. A packaging design type is defined by the design, size, material and thickness, manner of construction and packing, but may include various surface treatments. It also includes packagings which differ from the design type only in their lesser design height.

4.1.3 Tests must be repeated on production samples at intervals established by the appropriate national authority. For such tests on paper or fibreboard packagings, preparation at ambient conditions is considered equivalent to the provisions of 4.2.3.

4.1.4 Tests must also be repeated after each modification which alters the design, material or manner of construction of a packaging.

4.1.5 The appropriate national authority may permit the selective testing of packagings that differ only in minor respects from a tested type, e.g. smaller sizes of inner packagings or inner packagings of lower net mass; and packagings such as drums, bags and boxes which are produced with small reductions in external dimension(s).

4.1.6 Reserved.

Note.— For the conditions for assembling different inner packagings in an outer packaging and permissible variations in inner packagings, see 4;1.1.10.1.

4.1.7 Articles or inner packagings of any type for solids or liquids may be assembled and transported, without testing, in an outer packaging under the following conditions:

- a) The outer packaging must have been successfully tested in accordance with 4.3 with fragile (e.g. glass) inner packagings containing liquids using the Packing Group I drop height.
- b) The total combined gross mass of inner packagings must not exceed one-half the gross mass of inner packagings used for the drop test in a) above.
- c) The thickness of cushioning material between inner packagings and between inner packagings and the outside of the packaging must not be reduced below the corresponding thicknesses in the originally tested packaging; and if a single inner packaging was used in the original test, the thicknesses of cushioning between inner packagings must not be less than the thickness of cushioning between the outside of the packaging and the inner packaging in the original test. If either fewer or smaller inner packagings are used (as compared to the inner packagings used in the drop test), sufficient additional cushioning material must be used to take up void spaces.
- d) The outer packaging must have passed successfully the stacking test in 4.6 while empty. The total mass of identical packages must be based on the combined mass of inner packagings used for the drop test in a) above.
- e) Inner packagings containing liquids must be completely surrounded with a sufficient quantity of absorbent material to absorb the entire liquid contents of the inner packagings.

- f) If the outer packaging is intended to contain inner packagings for liquids and is not leakproof, or is intended to contain inner packagings for solids and is not siftproof, a means of containing any liquid or solid contents in the event of leakage must be provided in the form of a leakproof liner, plastic bag or other equally efficient means of containment. For packagings containing liquids, the absorbent material required by e) above must be placed inside the means of containing the liquid contents.
- g) Inner packagings containing liquids must comply with 4;1.1.6.
- h) Packagings must be marked in accordance with Part 6;2 as having been tested to Packing Group I performance for combination packagings. The marked gross mass in kilograms must be the sum of the mass of the outer packaging plus one half of the mass of the inner packaging(s) as used for the drop test referred to in a) above. Such a packaging mark must also contain a letter "V" as described in 1.2.6.

4.1.8 The appropriate national authority may at any time require proof, by tests in accordance with this Chapter, that serially produced packagings meet the requirements of the design type tests.

4.1.9 If an inner treatment or coating is required for safety reasons, it must retain its protective properties even after the tests.

4.1.10 Provided the validity of the test results is not affected, and with the approval of the appropriate national authority, several tests may be made on one sample.

4.2 PREPARATION OF PACKAGINGS FOR TESTING

4.2.1 Tests must be carried out on packagings prepared as for transport including, with respect to combination packagings, the inner packagings used. Inner or single receptacles or packagings must be filled to not less than 98 per cent of their maximum capacity for liquids or 95 per cent for solids. Bags must only be filled to the maximum mass at which they may be used. For other than bags, combination packagings where the inner packaging is designed to carry liquids and solids, separate testing is required for both liquid and solid contents. The substances or articles to be transported in the packaging may be replaced by other substances or articles except where this would invalidate the results of the tests. For solids, when another substance is used it must have the same physical characteristics (mass, grain size, etc.) as the substance to be carried. It is permissible to use additives, such as bags of lead shot, to achieve the requisite total package mass, so long as they are placed so that the test results are not invalidated.

4.2.2 In the drop tests for liquids, when another substance is used, it must be of similar relative density and viscosity to those of the substance being transported. Water may also be used for the liquid drop test under the conditions set forth in 4.3.5.

4.2.3 Paper or fibreboard packagings must be conditioned for at least 24 hours in an atmosphere having a controlled temperature and relative humidity (r.h.). There are three options, one of which must be chosen. The preferred atmosphere is 23°C ± 2°C and 50 per cent ± 2 per cent r.h. The two other options are 20°C ± 2°C and 65 per cent ± 2 per cent r.h., or 27°C ± 2°C and 65 per cent ± 2 per cent r.h.

Note.— Average values must fall within these limits. Short-term fluctuations and measurement limitations may cause individual measurements to vary by up to ±5 per cent relative humidity without significant impairment of test reproducibility.

4.2.4 Additional steps must be taken to ascertain that the plastic material used in the manufacture of plastic drums, plastic jerricans and composite packagings (plastic material) intended to contain liquid complies with the provisions in 3.1.7.1, 3.1.7.3 and 4;1.1.3. This may be done, for example, by submitting sample receptacles or packagings to a preliminary test extending over a long period, for example six months, during which the samples would remain filled with the substances they are intended to contain, and after which the samples must be submitted to the applicable tests listed in 4.3, 4.4, 4.5 and 4.6. For substances which may cause stress-cracking or weakening in plastic drums or jerricans, the sample, filled with the substance or another substance that is known to have at least as severe a stress-cracking influence on the plastic materials in question, must be subjected to a superimposed load equivalent to the total mass of identical packages which might be stacked on it during transport. The minimum stacking height, including the test sample, must be 3 m.

4.3 DROP TEST

4.3.1 Number of test samples (per design type and manufacturer) and drop orientation

For other than flat drops, the centre of gravity must be vertically over the point of impact. Where more than one orientation is possible for a given drop, the orientation most likely to result in failure of the packaging must be used.

4.3.2 Special preparation of test samples for the drop test

The temperature of the test sample and its contents must be reduced to -18°C or lower for the following packagings:

- a) plastic drums (see 3.1.7);
- b) plastic jerricans (see 3.1.7);
- c) plastic boxes other than expanded polystyrene boxes (see 3.1.12);
- d) composite packagings (plastic material) (see 3.1.18); and
- e) combination packagings with plastic inner packagings, other than plastic bags intended to contain solids or articles.

Where test samples are prepared in this way, the conditioning specified in 4.2.3 may be waived. Test liquids must be kept in the liquid state by the addition of antifreeze, if necessary.

<i>Packaging</i>	<i>Number of test samples</i>	<i>Drop orientation</i>
Steel drums Aluminium drums Steel jerricans Aluminium jerricans Plywood drums Fibre drums Plastic drums and jerricans Composite packagings which are in the shape of a drum	Six (three for each drop)	First drop (using three samples): the packaging must strike the target diagonally on the chime or, if the packaging has no chime, on a circumferential seam or an edge. Second drop (using the other three samples): the packaging must strike the target on the weakest part not tested by the first drop, for example a closure or, for some cylindrical drums, the welded longitudinal seam of the drum body.
Boxes of natural wood Plywood boxes Reconstituted wood boxes Fibreboard boxes Plastic boxes Steel or aluminium boxes Composite packagings which are in the shape of a box	Five (one for each drop)	First drop: flat on the bottom Second drop: flat on the top Third drop: flat on the long side Fourth drop: flat on the short side Fifth drop: on a corner
Bags — single-ply without a side seam, or multi-ply	Three (two drops per bag)	First drop: flat on a wide face Second drop: on an end of the bag
Bags — single-ply with a side seam	Three (three drops per bag)	First drop: flat on a wide face Second drop: flat on a narrow face Third drop: on an end of the bag

4.3.3 Removable head packagings for liquids must not be dropped until at least 24 hours after filling and closing to allow for any possible gasket relaxation.

4.3.4 Target

The target must be a non-resilient horizontal surface and must be:

- a) integral and massive enough to be immovable;
- b) flat with a surface kept free from local defects capable of influencing the test results;
- c) rigid enough to be non-deformable under test conditions and not liable to become damaged by the tests; and
- d) sufficiently large to ensure that the test package falls entirely upon the surface.

4.3.5 Drop height

For solids and liquids, if the test is performed with the solid or liquid to be transported or with another substance having essentially the same physical characteristics:

Packing Group I	Packing Group II	Packing Group III
1.8 m	1.2 m	0.8 m

For liquids in single packagings and for inner packagings of combination packagings, if the test is performed with water:

- a) where the substances to be transported have a relative density not exceeding 1.2:

Packing Group I	Packing Group II	Packing Group III
1.8 m	1.2 m	0.8 m

- b) where the substances to be transported have a relative density exceeding 1.2, the drop height must be calculated on the basis of the relative density (d) of the substance to be carried, rounded up to the first decimal, as follows:

Packing Group I	Packing Group II	Packing Group III
$d \times 1.5$ m	$d \times 1.0$ m	$d \times 0.67$ m

Note.— The term water includes water/antifreeze solutions with a minimum specific gravity of 0.95 for testing at -18°C .

4.3.6 Criteria for passing the test

4.3.6.1 Each packaging containing liquid must be leakproof when equilibrium has been reached between the internal and external pressures, except for inner packagings of combination packagings when it is not necessary that the pressures be equalized.

4.3.6.2 Where a packaging for solids undergoes a drop test and its upper face strikes the target, the test sample passes the test if the entire contents are retained by an inner packaging or inner receptacle (e.g. a plastic bag) even if the closure, while retaining its containment function, is no longer siftproof.

4.3.6.3 The packaging or outer packaging of a composite or combination packaging must not exhibit any damage liable to affect safety during transport. Inner receptacles, inner packagings, or articles must remain completely within the outer packaging and there must be no leakage of the filling substance from the inner receptacle or inner packaging(s).

4.3.6.4 Neither the outermost ply of a bag nor an outer packaging may exhibit any damage liable to affect safety during transport.

4.3.6.5 A slight discharge from the closure(s) upon impact is not considered to be a failure of the packaging provided that no further leakage occurs.

4.3.6.6 No rupture is permitted in packagings for goods of Class 1 which would permit the spillage of loose explosive substances or articles from the outer packaging.

4.4 LEAKPROOFNESS TEST

Note.— The leakproofness test must be performed on all design types of packagings intended to contain liquids; however, this test is not required for the inner packagings of combination packagings.

4.4.1 Number of test samples: three test samples per design type and manufacturer.

4.4.2 Test method and pressure to be applied: the packagings including their closures must be restrained under water for 5 minutes while an internal air pressure is applied; the method of restraint must not affect the results of the test. The air pressure (gauge) to be applied must be:

Packing Group I	Packing Group II	Packing Group III
Not less than 30 kPa (0.3 bar)	Not less than 20 kPa (0.2 bar)	Not less than 20 kPa (0.2 bar)

Other methods at least equally effective may be used.

4.4.3 Criterion for passing the test: there must be no leakage.

4.5 INTERNAL PRESSURE (HYDRAULIC) TEST

4.5.1 Packagings to be tested: the internal pressure (hydraulic) test must be carried out on all design types of metal, plastic and composite packagings intended to contain liquids. This test is not required for the inner packagings of combination packagings. For the internal pressure requirements for inner packagings see 4;1.1.6.

4.5.2 Number of test samples: three test samples per design type and manufacturer.

4.5.3 Test method and pressure to be applied: metal packagings including their closures must be subjected to the test pressure for 5 minutes. Plastic packagings and composite packagings (plastic material) including their closures must be subjected to the test pressure for 30 minutes. This pressure is the one to be included in the marking required by 2.1.1 d). The manner in which the packagings are supported must not invalidate the test. The test pressure must be applied continuously and evenly: it must be kept constant throughout the test period. The hydraulic pressure (gauge) applied, as determined by any one of the following methods, must be:

- a) not less than the total gauge pressure measured in the packaging (i.e. the vapour pressure of the filling liquid and the partial pressure of the air or other inert gases minus 100 kPa) at 55°C, multiplied by a safety factor of 1.5. This total gauge pressure must be determined on the basis of a maximum degree of filling in accordance with Part 4;1.1.5 and a filling temperature of 15°C. The test pressure must be not less than 95 kPa (not less than 75 kPa for liquids in Packing Group III of Class 3 or Division 6.1); or
- b) not less than 1.75 times the vapour pressure at 50°C of the liquid to be transported, minus 100 kPa but with a minimum test pressure of 100 kPa; or
- c) not less than 1.5 times the vapour pressure at 55°C of the liquid to be transported, minus 100 kPa but with a minimum test pressure of 100 kPa.

These are expressed as:

- a) $P_T = (P_{M55} \times 1.5)$ kPa with minima of 95 or 75 kPa;
- b) $P_T = (Vp_{50} \times 1.75) - 100$ kPa with a minimum of 100 kPa;
- c) $P_T = (Vp_{55} \times 1.5) - 100$ kPa with a minimum of 100 kPa;

where:

- P_T = Test pressure in kPa (gauge)
- P_{M55} = Pressure measured in the filled packaging at a temperature of 55°C
- Vp_{50} = Vapour pressure at 50°C
- Vp_{55} = Vapour pressure at 55°C.

4.5.4 In addition, packagings intended to contain liquids of Packing Group I must be tested to a minimum test pressure of 250 kPa (gauge) for a test period of 5 or 30 minutes depending upon the material of construction of the packaging.

4.5.5 Criteria for passing the test: no packaging may leak.

4.6 STACKING TEST

4.6.1 All design types of packagings other than bags must be subjected to a stacking test.

4.6.2 Number of test samples: three test samples per design type and manufacturer.

4.6.3 Test method: the test sample must be subjected to a force applied to the top surface of the test sample equivalent to the total weight of identical packages which might be stacked on it during transport: where the contents of the test samples are liquids with a relative density different from that of the liquid to be transported, the force must be calculated in relation to the latter. The minimum height of the stack including the test sample must be 3 m. The duration of the test must be 24 hours except that plastic drums, jerricans and composite packagings (6HH1 and 6HH2) intended for liquids must be subjected to the stacking test for a period of 28 days at a temperature of not less than 40°C.

4.6.4 Criteria for passing the test: no test sample may leak. In composite packagings or combination packagings, there must be no leakage of the filling substance from the inner receptacle or inner packaging. No test sample must show any deterioration which could adversely affect transport safety or any distortion liable to reduce its strength or cause instability in stacks of packages. Plastic packagings must be cooled to ambient temperature before the assessment.

4.7 TEST REPORT

4.7.1 A test report containing at least the following particulars must be drawn up and must be available to the users of the packaging:

- a) name and address of the test facility;
- b) name and address of the applicant (where appropriate);
- c) a unique test report identification;
- d) date of the test report;
- e) manufacturer of the packaging;
- f) description of the packaging type (e.g. dimensions, materials, closures, thickness, etc.), including method of manufacture (e.g. blow moulding); drawings and/or photographs may be included;
- g) maximum capacity;
- h) characteristics of the test contents (e.g. the viscosity and relative density for liquids and the particle size for solids);
- i) test descriptions and results;
- j) a signature and name and status of the signatory.

4.7.2 The test report must contain statements that:

- a) the packaging prepared as for transport was tested in accordance with the appropriate provisions of these Instructions or the equivalent provisions of Chapter 6 of the United Nations *Recommendations on the Transport of Dangerous Goods*; and
- b) the use of other packaging methods or components may render it invalid.

4.7.3 A copy of the test report must be made available to the appropriate national authority.

4.8 TEST REQUIREMENTS FOR SALVAGE PACKAGING

Salvage packagings (see 1;3.1) must be tested and marked in accordance with the requirements applicable to Packing Group II packagings intended for the transport of solids or inner packagings, except as follows:

- a) the test substance used in performing the tests must be water, and the packagings must be filled to not less than 98 per cent of their maximum capacity. It is permissible to use additives, such as bags of lead shot, to achieve the requisite total package mass so long as they are placed so that the test results are not affected. In performing the drop test, the drop height must meet the requirements of 4.3;
- b) packagings must have been successfully leakproofness tested at 30 kPa with the test results reflected in the test report required by 4.7.1;
- c) packagings for which retention of liquids is a basic function must, in addition, have been successfully tested in accordance with the internal pressure test specified in 4.5; and
- d) the marking required by 2.1.1 b) must be followed by the letter "T".

Chapter 5

REQUIREMENTS FOR THE CONSTRUCTION AND TESTING OF CYLINDERS AND CLOSED CRYOGENIC RECEPTACLES, AEROSOL DISPENSERS AND SMALL RECEPTACLES CONTAINING GAS (GAS CARTRIDGES) AND FUEL CELL CARTRIDGES CONTAINING LIQUEFIED FLAMMABLE GAS

Note 1.— Aerosol dispensers, small receptacles containing gas (gas cartridges) and fuel cell cartridges containing liquefied flammable gas are not subject to the requirements of 6;5.1 to 6;5.3.

Note 2.— For open cryogenic receptacles the requirements of Packing Instruction 202 must be met.

5.1 GENERAL REQUIREMENTS

5.1.1 Design and construction

5.1.1.1 Cylinders and closed cryogenic receptacles and their closures must be designed, manufactured, tested and equipped in such a way as to withstand all conditions, including fatigue, to which they will be subjected during normal conditions of transport.

5.1.1.2 In recognition of scientific and technological advances, and recognizing that cylinders and closed cryogenic receptacles other than those that are marked with a UN certification marking may be used on a national or regional basis, cylinders and closed cryogenic receptacles conforming to requirements other than those specified in these Instructions may be used if approved by the appropriate national authorities in the countries of transport and use.

5.1.1.3 In no case must the minimum wall thickness be less than that specified in the design and construction technical standards.

5.1.1.4 For welded cylinders and closed cryogenic receptacles, only metals of weldable quality must be used.

≠ 5.1.1.5 The test pressure of cylinders must be in accordance with Packing Instruction 200 or, for a chemical under pressure, with Packing Instruction 218. The test pressure for closed cryogenic receptacles must be in accordance with Packing Instruction 202. The test pressure of a metal hydride storage system must be in accordance with Packing Instruction 214. The test pressure of a cylinder for an adsorbed gas must be in accordance with Packing Instruction 219.

5.1.1.6 Not used.

5.1.1.7 Contact between dissimilar metals which could result in damage by galvanic action must be avoided.

5.1.1.8 The following additional requirements apply to the construction of closed cryogenic receptacles for refrigerated liquefied gases.

5.1.1.8.1 The mechanical properties of the metal used must be established for each closed cryogenic receptacle, including the impact strength and the bending coefficient.

5.1.1.8.2 The closed cryogenic receptacles must be thermally insulated. The thermal insulation must be protected against impact by means of a jacket. If the space between the closed cryogenic receptacle and the jacket is evacuated of air (vacuum-insulation), the jacket must be designed to withstand without permanent deformation an external pressure of at least 100 kPa (1 bar) calculated in accordance with a recognized technical code or a calculated critical collapsing pressure of not less than 200 kPa (2 bar) gauge pressure. If the jacket is so closed as to be gas-tight (e.g. in the case of vacuum-insulation), a device must be provided to prevent any dangerous pressure from developing in the insulating layer in the event of inadequate gas-tightness of the closed cryogenic receptacle or its fittings. The device must prevent moisture from penetrating into the insulation.

5.1.1.8.3 Closed cryogenic receptacles intended for the transport of refrigerated liquefied gases having a boiling point below -182°C at atmospheric pressure must not include materials that may react with oxygen or oxygen-enriched atmospheres in a dangerous manner when located in parts of the thermal insulation where there is a risk of contact with oxygen or oxygen-enriched liquid.

5.1.1.8.4 Closed cryogenic receptacles must be designed and constructed with suitable lifting and securing arrangements.

5.1.1.9 Additional requirements for the construction of pressure receptacles for acetylene

Cylinders for UN 1001— **Acetylene, dissolved** and UN 3374 — **Acetylene, solvent free** must be filled with a porous mass, uniformly distributed, of a type that conforms to the requirements and testing specified by the appropriate national authority and which:

- a) is compatible with the cylinder and does not form harmful or dangerous compounds either with the acetylene or with the solvent in the case of UN 1001; and
- b) is capable of preventing the spread of decomposition of the acetylene in the porous mass.

In the case of UN 1001, the solvent must be compatible with the cylinders.

5.1.2 Materials

5.1.2.1 Construction materials of cylinders and closed cryogenic receptacles and their closures which are in direct contact with dangerous goods must not be affected or weakened by the dangerous goods intended and must not cause a dangerous effect (e.g. catalysing a reaction or reacting with the dangerous goods).

5.1.2.2 Cylinders and closed cryogenic receptacles and their closures must be made of the materials specified in the design and construction technical standards and the applicable packing instruction for the substances intended for transport in the cylinder and closed cryogenic receptacle. The materials must be resistant to brittle fracture and to stress corrosion cracking as indicated in the design and construction technical standards.

5.1.3 Service equipment

5.1.3.1 Valves, piping and other fittings subjected to pressure, excluding pressure relief devices, must be designed and constructed so that the burst pressure is at least 1.5 times the test pressure of the cylinders and closed cryogenic receptacles.

5.1.3.2 Service equipment must be configured or designed to prevent damage that could result in the release of the cylinder and closed cryogenic receptacle contents during normal conditions of handling and transport. The filling and discharge valves and any protective caps must be capable of being secured against unintended opening. Valves must be protected as specified in 4;4.1.1.8.

5.1.3.3 Cylinders and closed cryogenic receptacles that are not capable of being handled manually or rolled must be fitted with devices (skids, rings, straps) ensuring that they can be safely handled by mechanical means and arranged so as not to impair the strength of, nor cause undue stresses in, the cylinder and closed cryogenic receptacle.

5.1.3.4 Individual cylinders and closed cryogenic receptacles must be equipped with pressure relief devices as specified in Packing Instruction 200(1), 202 or 214, or 5.1.3.6.4 and 5.1.3.6.5. Pressure-relief devices must be designed to prevent the entry of foreign matter, the leakage of gas and the development of any dangerous excess pressure.

5.1.3.5 Cylinders and closed cryogenic receptacles whose filling is measured by volume must be provided with a level indicator.

5.1.3.6 *Additional requirements for closed cryogenic receptacles*

5.1.3.6.1 Not used.

5.1.3.6.2 For sections of piping which can be closed at both ends and where liquid product can be trapped, a method of automatic pressure-relief must be provided to prevent excess pressure build-up within the piping.

5.1.3.6.3 Each connection to a closed cryogenic receptacle must be clearly marked to indicate its function (e.g. vapour or liquid phase).

5.1.3.6.4 *Pressure-relief devices*

5.1.3.6.4.1 Every closed cryogenic receptacle, having a nominal capacity in excess of 550 L, must be provided with at least two pressure-relief devices. The pressure-relief device must be of the type that will resist dynamic forces including surge.

5.1.3.6.4.2 Closed cryogenic receptacles, having a nominal capacity of 550 L or less, must be provided with at least one pressure-relief device and may, in addition have a frangible disc in parallel with the spring-loaded device in order to meet the requirements of 5.1.3.6.5. The pressure-relief device must be of the type that will resist dynamic forces including surge.

5.1.3.6.4.3 Connections to pressure-relief devices must be of sufficient size to enable the required discharge to pass unrestricted to the pressure-relief device.

5.1.3.6.4.4 All pressure-relief device inlets must, under maximum filling conditions, be situated in the vapour space of the closed cryogenic receptacle and the devices must be so arranged as to ensure that the escaping vapour is discharged unrestrictedly.

5.1.3.6.5 *Capacity and setting of pressure-relief devices*

Note.— In relation to pressure-relief devices, MAWP means the maximum effective gauge pressure permissible at the top of a loaded closed cryogenic receptacle in its operating position including the highest effective pressure during filling and discharge.

5.1.3.6.5.1 The pressure-relief device must open automatically at a pressure not less than the MAWP and be fully open at a pressure equal to 110 per cent of the MAWP. It must, after discharge, close at a pressure not lower than 10 per cent below the pressure at which discharge starts and must remain closed at all lower pressures.

5.1.3.6.5.2 Not used.

5.1.3.6.5.3 In the case of the loss of vacuum in a vacuum-insulated closed cryogenic receptacle, the combined capacity of all pressure-relief devices installed must be sufficient so that the pressure (including accumulation) inside the closed cryogenic receptacle does not exceed 120 per cent of the MAWP.

5.1.3.6.5.4 The required capacity of the pressure-relief devices must be calculated in accordance with an established technical code recognized by the appropriate national authority. (See, for example, the Compressed Gas Association (CGA) Publications S-1.2-2003 and S-1.1-2003.)

5.1.4 Approval of cylinders and closed cryogenic receptacles

5.1.4.1 The conformity of cylinders and closed cryogenic receptacles must be assessed at the time of manufacture as required by the appropriate national authority. Cylinders and closed cryogenic receptacles must be inspected, tested and approved by an inspection body. The technical documentation must include full specifications on design and construction, and full documentation on the manufacturing and testing.

5.1.4.2 Quality assurance systems must conform to the requirements of the appropriate national authority.

5.1.5 Initial inspection and testing

5.1.5.1 New cylinders, other than closed cryogenic receptacles and metal hydride storage systems, must be subjected to inspection and testing during and after manufacture in accordance with the applicable design standards including the following:

On an adequate sample of cylinders:

- a) testing of the mechanical characteristics of the material of construction;
- b) verification of the minimum wall thickness;
- c) verification of the homogeneity of the material for each manufacturing batch;
- d) inspection of the external and internal conditions of the cylinders;
- e) inspection of the neck threads;
- f) verification of the conformance with the design standard;

For all cylinders:

- g) a hydraulic pressure test. Cylinders must withstand the test pressure without expansion greater than that allowed in the design specifications;

Note.— With the agreement of the appropriate national authority, the hydraulic pressure test may be replaced by a test using a gas, where such an operation does not entail any danger.

- h) inspection and assessment of manufacturing defects and either repairing them or rendering the cylinders unserviceable. In the case of welded cylinders, particular attention must be paid to the quality of the welds;
- i) an inspection of the markings on the cylinders;
- j) in addition, cylinders intended for the transport of UN 1001 — **Acetylene, dissolved**, and UN 3374 — **Acetylene, solvent free**, must be inspected to ensure proper installation and condition of the porous mass and, if applicable, the quantity of solvent.

5.1.5.2 On an adequate sample of closed cryogenic receptacles, the inspections and tests specified in 5.1.5.1 a), b), d) and f) must be performed. In addition, welds must be inspected by radiographic, ultrasonic or another suitable non-destructive test method on a sample of closed cryogenic receptacles according to the applicable design and construction standard. This weld inspection does not apply to the jacket. Additionally, all closed cryogenic receptacles must undergo the inspections and tests specified in 5.1.5.1 g), h) and i), as well as a leakproofness test and a test of the satisfactory operation of the service equipment after assembly.

5.1.5.3 For metal hydride storage systems, it must be verified that the inspections and tests specified in 5.1.5.1 a), b), c), d), e) if applicable, f), g), h) and i) have been performed on an adequate sample of the receptacles used in the metal hydride storage system. In addition, on an adequate sample of metal hydride storage systems, the inspections and tests specified in 5.1.5.1 c) and f) must be performed, as well as 5.1.5.1 e) if applicable, and inspection of the external conditions of the metal hydride storage system. Additionally, all metal hydride storage systems must undergo the initial inspections and tests specified in 5.1.5.1 h) and i), as well as a leakproofness test and a test of the satisfactory operation of the service equipment.

5.1.6 Periodic inspection and testing

5.1.6.1 Refillable cylinders must be subjected to periodic inspections and tests by a body authorized by the appropriate national authority, in accordance with the following:

- a) check of the external conditions of the cylinder and verification of the equipment and the external markings;
- b) check of the internal conditions of the cylinder (e.g. internal inspection, verification of minimum wall thickness);
- c) check of the threads if there is evidence of corrosion or if the fittings are removed;
- d) a hydraulic pressure test and, if necessary, verification of the characteristics of the material by suitable tests;

Note 1.— With the agreement of the appropriate national authority, the hydraulic pressure test may be replaced by a test using a gas, where such an operation does not entail any danger.

Note 2.— With the agreement of the appropriate national authority, the hydraulic pressure test of cylinders may be replaced by an equivalent method based on acoustic emission testing or a combination of acoustic emission testing and ultrasound examination. ISO 16148:2006 may be used as a guide for acoustic emission testing procedures.

Note 3.— The hydraulic pressure test may be replaced by ultrasonic examination carried out in accordance with ISO 10461:2005 + A1:2006 for seamless aluminium alloy gas cylinders and in accordance with ISO 6406:2005 for seamless steel gas cylinders.

- e) check of service equipment, other accessories and pressure-relief devices, if to be reintroduced into service.

Note.— For the periodic inspection and test frequencies, see Packing Instruction 200 or, for a chemical under pressure, Packing Instruction 218.

5.1.6.2 Cylinders intended for the transport of UN 1001 — **Acetylene, dissolved**, and UN 3374 — **Acetylene, solvent free**, must be examined only as specified in 5.1.6.1 a), c) and e). In addition, the condition of the porous material (e.g. cracks, top clearance, loosening, settlement) must be examined.

5.1.6.3 Pressure relief valves for closed cryogenic receptacles must be subject to periodic inspections and tests.

5.1.7 Requirements for manufacturers

5.1.7.1 The manufacturer must be technically able and must possess all resources required for the satisfactory manufacture of cylinders and closed cryogenic receptacles; this relates in particular to qualified personnel:

- a) to supervise the entire manufacturing process;
- b) to carry out joining of materials; and
- c) to carry out the relevant tests.

5.1.7.2 The proficiency test of a manufacturer must in all instances be carried out by an inspection body approved by the appropriate national authority of the country of approval.

5.1.8 Requirements for inspection bodies

Inspection bodies must be independent from manufacturing enterprises and competent to perform the tests, inspections and approvals required.

5.2 REQUIREMENTS FOR UN CYLINDERS AND CLOSED CRYOGENIC RECEPTACLES

- ≠ In addition to the general requirements of 5.1, UN cylinders and closed cryogenic receptacles must comply with the requirements of this section, including the standards, as applicable. Manufacture of new UN cylinders and closed cryogenic receptacles or service equipment according to any particular standard in 5.2.1 and 5.2.3 is not permitted after the date shown in the right hand column of the tables.
- ≠ *Note 1.— With the agreement of the appropriate national authority, more recently published versions of the standards, if available, may be used.*
- + *Note 2.— UN cylinders and closed cryogenic receptacles and service equipment constructed according to standards applicable at the date of manufacture may continue in use subject to the periodic inspection provisions of these Instructions.*

5.2.1 Design, construction and initial inspection and testing

5.2.1.1 The following standards apply for the design, construction and initial inspection and test of UN cylinders, except that inspection requirements related to the conformity assessment system and approval must be in accordance with 5.2.5:

	Reference	Title	Applicable for manufacture
≠	ISO 9809-1:1999	Gas cylinders — Refillable seamless steel gas cylinders — Design, construction and testing — Part 1: Quenched and tempered steel cylinders with tensile strength less than 1 100 MPa. <i>Note.— The note concerning the F factor in section 7.3 of this standard must not be applied for UN cylinders.</i>	Until 31 December 2018
+	ISO 9809-1:2010	Gas cylinders — Refillable seamless steel gas cylinders — Design, construction and testing — Part 1: Quenched and tempered steel cylinders with tensile strength less than 1 100 MPa.	Until further notice
≠	ISO 9809-2:2000	Gas cylinders — Refillable seamless steel gas cylinders — Design, construction and testing — Part 2: Quenched and tempered steel cylinders with tensile strength greater than or equal to 1 100 MPa.	Until 31 December 2018
+	ISO 9809-2:2010	Gas cylinders — Refillable seamless steel gas cylinders — Design, construction and testing — Part 2: Quenched and tempered steel cylinders with tensile strength greater than or equal to 1 100 MPa.	Until further notice
≠	ISO 9809-3:2000	Gas cylinders — Refillable seamless steel gas cylinders — Design, construction and testing — Part 3: Normalized steel cylinders.	Until 31 December 2018
+	ISO 9809-3:2010	Gas cylinders — Refillable seamless steel gas cylinders — Design, construction and testing — Part 3: Normalized steel cylinders.	Until further notice
≠	ISO 7866:1999	Gas cylinders — Refillable seamless aluminium alloy gas cylinders — Design, construction and testing. <i>Note.— The note concerning the F factor in section 7.2 of this standard must not be applied for UN cylinders. Aluminium alloy 6351A — T6 or equivalent must not be authorized.</i>	Until further notice
≠	ISO 4706:2008	Gas cylinders — Refillable welded steel cylinders — Test pressure 60 bar and below.	Until further notice
≠	ISO 18172-1:2007	Gas cylinders — Refillable welded stainless steel cylinders — Part 1: Test pressure 6 MPa and below.	Until further notice
≠	ISO 20703:2006	Gas cylinders — Refillable welded aluminium-alloy cylinders — Design, construction and testing.	Until further notice
≠	ISO 11118:1999	Gas cylinders — Non-refillable metallic gas cylinders — Specification and test methods.	Until further notice
≠	ISO 11119-1:2002	Gas cylinders of composite construction — Specification and test methods — Part 1: Hoop wrapped composite gas cylinders.	Until further notice
≠	ISO 11119-2:2002	Gas cylinders of composite construction — Specification and test methods — Part 2: Fully wrapped fibre reinforced composite gas cylinders with load-sharing metal liners.	Until further notice
≠	ISO 11119-3:2002	Gas cylinders of composite construction — Specification and test methods — Part 3: Fully wrapped fibre reinforced composite gas cylinders with non-load-sharing metallic or non-metallic liners.	Until further notice

Note 1.— In the above-referenced standards, composite cylinders must be designed for unlimited service life.

Note 2.— After the first 15 years of service, composite cylinders manufactured according to these standards, may be approved for extended service by the appropriate national authority which was responsible for the original approval of the cylinders and which will base its decision on the test information supplied by the manufacturer or owner or user.

5.2.1.2 Not used.

5.2.1.3 The following standards apply for the design, construction and initial inspection and test of UN acetylene cylinders except that inspection requirements related to the conformity assessment system and approval must be in accordance with 5.2.5.

Note.— The maximum of 1 000 L volume as mentioned in the ISO standard ISO 21029-1:2004 Cryogenic vessels, does not apply for refrigerated liquefied gases in closed cryogenic receptacles installed in apparatus (e.g. MRI or cooling machines).

For the cylinder shell:

	Reference	Title	Applicable for manufacture
+	ISO 9809-1:1999	Gas cylinders — Refillable seamless steel gas cylinders — Design, construction and testing — Part 1: Quenched and tempered steel cylinders with tensile strength less than 1 100 MPa. <i>Note.— The note concerning the F factor in section 7.3 of this standard must not be applied for UN cylinders.</i>	Until 31 December 2018
+	ISO 9809-1:2010	Gas cylinders — Refillable seamless steel gas cylinders — Design, construction and testing — Part 1: Quenched and tempered steel cylinders with tensile strength less than 1 100 MPa.	Until further notice
≠	ISO 9809-3:2000	Gas cylinders — Refillable seamless steel gas cylinders — Design, construction and testing — Part 3: Normalized steel cylinders.	Until 31 December 2018
+	ISO 9809-3:2010	Gas cylinders — Refillable seamless steel gas cylinders — Design, construction and testing — Part 3: Normalized steel cylinders.	Until further notice

For the porous mass in the cylinder:

	Reference	Title	Applicable for manufacture
+	ISO 3807-1:2000	Cylinders for acetylene — Basic requirements — Part 1: Cylinders without fusible plugs.	Until further notice
≠	ISO 3807-2:2000	Cylinders for acetylene — Basic requirements — Part 2: Cylinders with fusible plugs.	Until further notice

5.2.1.4 The following standard applies for the design, construction and initial inspection and test of UN closed cryogenic receptacles, except that inspection requirements related to the conformity assessment system and approval must be in accordance with 5.2.5:

	Reference	Title	Applicable for manufacture
+	ISO 21029-1:2004	Cryogenic vessels — Transportable vacuum insulated vessels of not more than 1 000 L volume — Part 1: Design, fabrication, inspection and tests.	Until further notice

5.2.1.5 The following standards apply for the design, construction, and initial inspection and test of UN metal hydride storage systems, except that inspection requirements related to the conformity assessment system and approval must be in accordance with 5.2.5:

	Reference	Title	Applicable for manufacture
+	ISO 16111:2008	Transportable gas storage devices — Hydrogen absorbed in reversible metal hydride.	Until further notice

5.2.1.6 Not used.

5.2.1.7 The following standards apply for the design, construction and initial inspection and test of UN cylinders for adsorbed gases except that the inspection requirements related to the conformity assessment system and approval must be in accordance with 5.2.5.

	Reference	Title	Applicable for manufacture
+	ISO 11513:2011	Gas cylinders — Refillable welded steel cylinders containing materials for sub-atmospheric gas packaging (excluding acetylene) — Design, construction, testing, use and periodic inspection.	Until further notice
+	ISO 9809-1:2010	Gas cylinders — Refillable seamless steel gas cylinders — Design, construction and testing — Part 1: Quenched and tempered steel cylinders with tensile strength less than 1 100 MPa.	Until further notice

5.2.2 Materials

In addition to the material requirements specified in the cylinder and closed cryogenic receptacle design and construction standards, and any restrictions specified in the applicable Packing Instruction for the gas(es) to be transported (e.g. Packing Instruction 200, Packing Instruction 202 or Packing Instruction 214), the following standards apply to material compatibility:

+	Reference	Title	Applicable for manufacture
≠	ISO 11114-1:2012	Gas cylinders — Compatibility of cylinder and valve materials with gas contents — Part 1: Metallic materials.	Until further notice
≠	ISO 11114-2:2000	Transportable gas cylinders — Compatibility of cylinder and valve materials with gas contents — Part 2: Non-metallic materials.	Until further notice

>

5.2.3 Service equipment

The following standards apply to closures and their protection:

+	Reference	Title	Applicable for manufacture
+	ISO 11117:1998	Gas cylinders — Valve protection caps and valve guards for industrial and medical gas cylinders — Design, construction and tests.	Until 31 December 2014
≠	ISO 11117:2008+ Cor 1:2009	Gas cylinders — Valve protection caps and valve guards — Design, construction and tests.	Until further notice
+	ISO 10297:1999	Gas cylinders — Refillable gas cylinder valves — Specification and type testing.	Until 31 December 2008
≠	ISO 10297:2006	Gas cylinders — Refillable gas cylinder valves — Specification and type testing.	Until further notice
≠	ISO 13340:2001	Transportable gas cylinders — Cylinder valves for non-refillable cylinders — Specification and prototype testing.	Until further notice

For UN metal hydride storage systems, the requirements specified in the following standard apply to closures and their protection:

+	Reference	Title	Applicable for manufacture
≠	ISO 16111:2008	Transportable gas storage devices — Hydrogen absorbed in reversible metal hydride.	Until further notice

5.2.4 Periodic inspection and test

The following standards apply to the periodic inspection and testing of UN cylinders and UN metal hydride storage systems:

+	Reference	Title	Applicable for manufacture
≠	ISO 6406:2005	Seamless steel gas cylinders — Periodic inspection and testing.	Until further notice
≠	ISO 10460:2005	Gas cylinders — Welded carbon-steel gas cylinders — Periodic inspection and testing. <i>Note.— The repair of welds described in clause 12.1 of this standard must not be permitted. Repairs described in clause 12.2 require the approval of the appropriate national authority which approved the periodic inspection and test body in accordance with 5.2.6.</i>	Until further notice
≠	ISO 10461:2005/A1:2006	Seamless aluminium-alloy gas cylinders — Periodic inspection and testing.	Until further notice
≠	ISO 10462:2005	Transportable cylinders for dissolved acetylene — Periodic inspection and maintenance.	Until further notice
+	ISO 11513:2011	Gas cylinders — Refillable welded steel cylinders containing materials for sub-atmospheric gas packaging (excluding acetylene) — Design, construction, testing, use and periodic inspection.	Until further notice
≠	ISO 11623:2002	Transportable gas cylinders — Periodic inspection and testing of composite gas cylinders.	Until further notice
≠	ISO 16111:2008	Transportable gas storage devices — Hydrogen absorbed in reversible metal hydride.	Until further notice

Note.— The repair of welds described in clause 12.1 of this standard must not be permitted. Repairs described in clause 12.2 require the approval of the appropriate national authority which approved the periodic inspection and test body in accordance with 5.2.6.

5.2.5 Conformity assessment system and approval for manufacture of cylinders and closed cryogenic receptacles

5.2.5.1 Definitions

For the purposes of this section:

Conformity assessment system: a system for appropriate national authority approval of a manufacturer, by cylinder and closed cryogenic receptacle design type approval, approval of manufacturer's quality system and approval of inspection bodies.

Design type: a cylinder and closed cryogenic receptacle design as specified by a particular cylinder and closed cryogenic receptacle standard.

Verify: confirm by examination or provision of objective evidence that specified requirements have been fulfilled.

5.2.5.2 General requirements

5.2.5.2.1 Appropriate national authority

5.2.5.2.1.1 The appropriate national authority that approves the cylinder and closed cryogenic receptacle must approve the conformity assessment system for the purpose of ensuring that cylinders and closed cryogenic receptacles conform to the requirements of these Instructions. In instances where the appropriate national authority that approves a cylinder and closed cryogenic receptacle is not the appropriate national authority in the country of manufacture, the marks of the approval country and the country of manufacture must be indicated in the cylinder and closed cryogenic receptacle marking (see 5.2.7 and 5.2.8). The appropriate national authority of the country of approval must supply to its counterpart in a country of use, upon request, evidence demonstrating compliance to this conformity assessment system.

5.2.5.2.2 The appropriate national authority may delegate its conformity assessment system functions in whole or in part.

5.2.5.2.3 The appropriate national authority must ensure that a current list of approved inspection bodies and their identity marks and approved manufacturers and their identity marks is available.

5.2.5.2.4 Inspection body

5.2.5.2.4.1 The inspection body must be approved by the appropriate national authority for the inspection of cylinders and closed cryogenic receptacles and must:

- a) have a staff with an organizational structure, capable, trained, competent and skilled, to satisfactorily perform its technical functions;
- b) have access to suitable and adequate facilities and equipment;
- c) operate in an impartial manner and be free from any influence which could prevent it from doing so;
- d) ensure commercial confidentiality of the commercial and proprietary activities of the manufacturer and other bodies;
- e) maintain clear demarcation between actual inspection body functions and unrelated functions;
- f) operate a documented quality system;
- g) ensure that the tests and inspections specified in the relevant cylinder and closed cryogenic receptacle standard and these instructions are performed; and
- h) maintain an effective and appropriate report and record system in accordance with 5.2.5.6.

5.2.5.2.5 The inspection body must perform design type approval, and cylinder and closed cryogenic receptacle production testing, inspection and certification to verify conformity with the relevant cylinder and closed cryogenic receptacle standard (see 5.2.5.4 and 5.2.5.5).

5.2.5.2.6 Manufacturer

The manufacturer must:

- a) operate a documented quality system in accordance with 5.2.5.3;
- b) apply for design type approvals in accordance with 5.2.5.4;
- c) select an inspection body from the list of approved inspection bodies maintained by the appropriate national authority in the country of approval; and
- d) maintain records in accordance with 5.2.5.6.

5.2.5.2.7 *Testing laboratory*

The testing laboratory must have:

- a) staff with an organizational structure, sufficient in number, competence and skill; and
- b) suitable and adequate facilities and equipment to perform, to the satisfaction of the inspection body, the tests required by the manufacturing standard.

5.2.5.3 *Manufacturer's quality system*

5.2.5.3.1 The quality system must contain all the elements, requirements and provisions adopted by the manufacturer. It must be documented in a systematic and orderly manner in the form of written policies, procedures and instructions.

The contents must in particular include adequate descriptions of:

- a) the organizational structure and responsibilities of personnel with regard to design and product quality;
- b) the design control and design verification techniques, processes and procedures that will be used when designing the cylinders and closed cryogenic receptacles;
- c) the relevant cylinder and closed cryogenic receptacle manufacturing, quality control, quality assurance, and process operation instructions that will be used;
- d) quality records, such as inspection reports, test data and calibration data;
- e) management reviews to ensure the effective operation of the quality system arising from the audits in accordance with 5.2.5.3.2;
- f) the process describing how customer requirements are met;
- g) the process for control of documents and their revision;
- h) the means for control of non-conforming cylinders and closed cryogenic receptacles, purchased components, in-process and final materials; and
- i) training programmes and qualification procedures for relevant personnel.

5.2.5.3.2 *Audit of the quality system*

5.2.5.3.2.1 The quality system must be initially assessed to determine whether it meets the requirements in 5.2.5.3.1 to the satisfaction of the appropriate national authority.

5.2.5.3.2.2 The manufacturer must be notified of the results of the audit. The notification must contain the conclusions of the audit and any corrective actions required.

5.2.5.3.2.3 Periodic audits must be carried out, to the satisfaction of the appropriate national authority, to ensure that the manufacturer maintains and applies the quality system. Reports of the periodic audits must be provided to the manufacturer.

5.2.5.3.3 *Maintenance of the quality system*

5.2.5.3.3.1 The manufacturer must maintain the quality system as approved in order that it remains adequate and efficient.

5.2.5.3.3.2 The manufacturer must notify the appropriate national authority that approved the quality system, of any intended changes. The proposed changes must be evaluated in order to determine whether the amended quality system will still satisfy the requirements in 5.2.5.3.1.

5.2.5.4 *Approval process*

5.2.5.4.1 *Initial design type approval*

The initial design type approval must consist of the approval of the manufacturer's quality system and the approval of the cylinder and closed cryogenic receptacle design to be produced. An application for an initial design type approval must meet the requirements of 5.2.5.4.2 to 5.2.5.4.6 and 5.2.5.4.9.

5.2.5.4.2 A manufacturer desiring to produce cylinders and closed cryogenic receptacles in accordance with a cylinder and closed cryogenic receptacle standard and these Instructions must apply for, obtain and retain a Design Type Approval Certificate issued by the appropriate national authority in the country of approval for at least one cylinder and closed cryogenic receptacle design type in accordance with the procedure given in 5.2.5.4.9. This certificate must, on request, be submitted to the appropriate national authority of the country of use.

5.2.5.4.3 An application must be made for each manufacturing facility and must include:

- a) the name and registered address of the manufacturer and, in addition, if the application is submitted by an authorized representative, its name and address;
- b) the address of the manufacturing facility (if different from the above);
- c) the name and title of the person(s) responsible for the quality system;
- d) the designation of the cylinder and closed cryogenic receptacle and the relevant cylinder and closed cryogenic receptacle standard;
- e) details of any refusal of approval of a similar application by any other appropriate national authority;
- f) the identity of the inspection body for design type approval;
- g) documentation on the manufacturing facility as specified under 5.2.5.3.1;
- h) the technical documentation required for design type approval, which must enable verification of the conformity of the cylinders and closed cryogenic receptacles with the requirements of the relevant cylinder and closed cryogenic receptacle design standard. The technical documentation must cover the design and method of manufacture and must contain, as far as is relevant for assessment, at least the following:
 - i) cylinder and closed cryogenic receptacle design standard, design and manufacturing drawings, showing components and sub-assemblies, if any;
 - ii) descriptions and explanations necessary for the understanding of the drawings and intended use of the cylinders and closed cryogenic receptacles;
 - iii) a list of the standards necessary to fully define the manufacturing process;
 - iv) design calculations and material specifications; and
 - v) design type approval test reports, describing the results of examinations and tests carried out in accordance with 5.2.5.4.9.

5.2.5.4.4 An initial audit in accordance with 5.2.5.3.2 must be performed to the satisfaction of the appropriate national authority.

5.2.5.4.5 If the manufacturer is denied approval, the appropriate national authority must provide written detailed reasons for such denial.

5.2.5.4.6 Following approval, changes to the information submitted under 5.2.5.4.3 relating to the initial approval must be provided to the appropriate national authority.

5.2.5.4.7 *Subsequent design type approvals*

An application for a subsequent design type approval must encompass the requirements of 5.2.5.4.8 and 5.2.5.4.9, provided a manufacturer is in possession of an initial design type approval. In such a case, the manufacturer's quality system according to 5.2.5.3 must have been approved during the initial design type approval and must be applicable for the new design.

5.2.5.4.8 The application must include:

- a) the name and address of the manufacturer and, in addition, if the application is submitted by an authorized representative, its name and address;
- b) details of any refusal of approval of a similar application by any other appropriate national authority;
- c) evidence that initial design type approval has been granted; and
- d) the technical documentation, as described in 5.2.5.4.3 h).

5.2.5.4.9 *Procedure for design type approval*

5.2.5.4.9.1 The inspection body must:

- a) examine the technical documentation to verify that:
 - i) the design is in accordance with the relevant provisions of the standard; and
 - ii) the prototype lot has been manufactured in conformity with the technical documentation and is representative of the design;

- b) verify that the production inspections have been carried out as required in accordance with 5.2.5.5;
- c) select cylinders and closed cryogenic receptacles from a prototype production lot and supervise the tests of these cylinders and closed cryogenic receptacles as required for design type approval;
- d) perform or have performed the examinations and tests specified in the cylinder and closed cryogenic receptacle standard to determine that:
 - i) the standard has been applied and fulfilled; and
 - ii) the procedures adopted by the manufacturer meet the requirements of the standard; and
- e) ensure that the various type approval examinations and tests are correctly and competently carried out.

5.2.5.4.9.2 After prototype testing has been carried out with satisfactory results and all applicable requirements of 5.2.5.4 have been satisfied, a Design Type Approval Certificate must be issued which must include the name and address of the manufacturer, results and conclusions of the examination, and the necessary data for identification of the design type.

5.2.5.4.9.3 If the manufacturer is denied a design type approval, the appropriate national authority must provide written detailed reasons for such denial.

5.2.5.4.10 *Modifications to approved design types*

The manufacturer must either:

- a) inform the issuing appropriate national authority of modifications to the approved design type, where such modifications do not constitute a new design, as specified in the cylinder and closed cryogenic receptacle standard; or
- b) request a subsequent design type approval where such modifications constitute a new design according to the relevant cylinder and closed cryogenic receptacle standard. This additional approval must be given in the form of an amendment to the original Design Type Approval Certificate.

5.2.5.4.11 Upon request, the appropriate national authority must communicate to any other appropriate national authority, information concerning design type approval, modifications of approvals, and withdrawn approvals.

5.2.5.5 *Production inspection and certification*

5.2.5.5.1 An inspection body, or its delegate, must carry out the inspection and certification of each cylinder. The inspection body selected by the manufacturer for inspection and testing during production may be different from the inspection body used for the design type approval testing.

5.2.5.5.2 Where it can be demonstrated to the satisfaction of the inspection body that the manufacturer has trained and competent inspectors, independent of the manufacturing operations, inspection may be performed by those inspectors. In such a case, the manufacturer must maintain training records of the inspectors.

5.2.5.5.3 The inspection body must verify that the inspections by the manufacturer and tests performed on those cylinders and closed cryogenic receptacles, fully conform to the standards and requirements of these Instructions. Should non-conformance in conjunction with this inspection and testing be determined, the permission to have inspection performed by the manufacturer's inspectors may be withdrawn.

5.2.5.5.4 The manufacturer must, after approval by the inspection body, make a declaration of conformity with the certified design type. The application of the cylinder and closed cryogenic receptacle certification marking must be considered a declaration that the cylinder and closed cryogenic receptacle comply with the applicable cylinder and closed cryogenic receptacle standards, the requirements of this conformity assessment system and these Instructions. The inspection body must affix or delegate the manufacturer to affix the cylinder and closed cryogenic receptacle certification marking and the registered mark of the inspection body to each approved cylinder or closed cryogenic receptacle.

5.2.5.5.5 A certificate of compliance, signed by the inspection body and the manufacturer, must be issued before the cylinders and closed cryogenic receptacles are filled.

5.2.5.6 *Records*

Design type approval and certificate of compliance records must be retained by the manufacturer and the inspection body for not less than 20 years.

5.2.6 Approval system for periodic inspection and test of cylinders and closed cryogenic receptacles

5.2.6.1 Definitions

For the purposes of this section:

Approval system: means a system for the appropriate national authority approval of a body performing the periodic inspection and test of cylinders and closed cryogenic receptacles (hereinafter referred to as “periodic inspection and test body”), including approval of that body’s quality system.

5.2.6.2 General requirements

5.2.6.2.1 Appropriate national authority

5.2.6.2.1.1 The appropriate national authority must establish an approval system for the purpose of ensuring that the periodic inspection and test of cylinders and closed cryogenic receptacles conform to the requirements of these Instructions. In instances where the appropriate national authority that approves the body performing periodic inspection and test of a cylinder and closed cryogenic receptacle is not the appropriate national authority of the country approving the manufacture of the cylinder, the marks of the approval country of periodic inspection and test must be indicated in the cylinder and closed cryogenic receptacle marking (see 5.2.7).

5.2.6.2.1.2 The appropriate national authority of the country of approval for the periodic inspection and test must supply, upon request, evidence demonstrating compliance with this approval system, including the records of the periodic inspection and test, to its counterpart in a country of use.

5.2.6.2.1.3 The appropriate national authority of the country of approval may terminate the approval certificate referred to in 5.2.6.4.1 upon evidence demonstrating non-compliance with the approval system.

5.2.6.2.2 The appropriate national authority may delegate its functions in this approval system, in whole or in part.

5.2.6.2.3 The appropriate national authority must ensure that a current list of approved periodic inspection and test bodies and their identity marks is available.

5.2.6.2.4 Periodic inspection and test body

The periodic inspection and test body must be approved by the appropriate national authority and must:

- a) have a staff with an organizational structure, capable, trained, competent and skilled to satisfactorily perform its technical functions;
- b) have access to suitable and adequate facilities and equipment;
- c) operate in an impartial manner and be free from any influence that could prevent it from doing so;
- d) ensure commercial confidentiality;
- e) maintain clear demarcation between actual periodic inspection and test body functions and unrelated functions;
- f) operate a documented quality system in accordance with 5.2.6.3;
- g) apply for approval in accordance with 5.2.6.4;
- h) ensure that the periodic inspections and tests are performed in accordance with 5.2.6.5; and
- i) maintain an effective and appropriate report and record system in accordance with 5.2.6.6.

5.2.6.3 Quality system and audit of the periodic inspection and test body

5.2.6.3.1 Quality system

5.2.6.3.1.1 The quality system must contain all the elements, requirements and provisions adopted by the periodic inspection and test body. It must be documented in a systematic and orderly manner in the form of written policies, procedures and instructions.

5.2.6.3.1.2 The quality system must include:

- a) a description of the organizational structure and responsibilities;
- b) the relevant inspection and test, quality control, quality assurance and process operation instructions that will be used;

- c) quality records, such as inspection reports, test data, calibration data and certificates;
- d) management reviews to ensure the effective operation of the quality system arising from the audits performed in accordance with 5.2.6.3.2;
- e) a process for control of documents and their revision;
- f) a means for control of non-conforming cylinders and closed cryogenic receptacles; and training programmes and qualification procedures for relevant personnel.

5.2.6.3.2 *Audit*

5.2.6.3.2.1 The periodic inspection and test body and its quality system must be audited in order to determine whether it meets the requirements of these Instructions to the satisfaction of the appropriate national authority.

5.2.6.3.2.2 An audit must be conducted as part of the initial approval process (see 5.2.6.4.3). An audit may be required as part of the process to modify an approval (see 5.2.6.4.6).

5.2.6.3.2.3 Periodic audits must be conducted, to the satisfaction of the appropriate national authority, to ensure that the periodic inspection and test body continues to meet the requirements of these Instructions.

5.2.6.3.2.4 The periodic inspection and test body must be notified of the results of any audit. The notification must contain the conclusions of the audit and any corrective actions required.

5.2.6.3.3 *Maintenance of the quality system*

5.2.6.3.3.1 The periodic inspection and test body must maintain the quality system as approved in order that it remains adequate and efficient.

5.2.6.3.3.2 The periodic inspection and test body must notify the appropriate national authority that approved the quality system, of any intended changes, in accordance with the process for modification of an approval in 5.2.6.4.6.

5.2.6.4 *Approval process for periodic inspection and test bodies*

5.2.6.4.1 *Initial approval*

5.2.6.4.1.1 A body desiring to perform periodic inspection and test of cylinders and closed cryogenic receptacles in accordance with a cylinder and closed cryogenic receptacle standard and these Instructions must apply for, obtain and retain an Approval Certificate issued by the appropriate national authority.

5.2.6.4.1.2 This written approval must, on request, be submitted to the appropriate national authority of a country of use.

5.2.6.4.2 An application must be made for each periodic inspection and test body and must include:

- a) the name and address of the periodic inspection and test body and, if the application is submitted by an authorized representative, its name and address;
- b) the address of each facility performing the periodic inspection and test;
- c) the name and title of the person(s) responsible for the quality system;
- d) the designation of the cylinders and closed cryogenic receptacles, the periodic inspection and test methods and the relevant cylinder and closed cryogenic receptacle standards encompassed by the quality system;
- e) documentation on each facility, the equipment and the quality system as specified under 5.2.6.3.1;
- f) the qualifications and training records of the periodic inspection and test personnel; and
- g) details of any refusal of approval of a similar application by any other appropriate national authority.

5.2.6.4.3 The appropriate national authority must:

- a) examine the documentation to verify that the procedures are in accordance with the requirements of the relevant cylinder and closed cryogenic receptacle standards and these Instructions; and
- b) conduct an audit in accordance with 5.2.6.3.2 to verify that the inspections and tests are carried out as required by the relevant cylinder and closed cryogenic receptacle standards and these Instructions, to the satisfaction of the appropriate national authority.

5.2.6.4.4 After the audit has been carried out with satisfactory results and all applicable requirements of 5.2.6.4 have been satisfied, an Approval Certificate must be issued. It must include the name of the periodic inspection and test body, the registered mark, the address of each facility and the necessary data for identification of its approved activities (e.g. designation of cylinders and closed cryogenic receptacles, periodic inspection and test method and cylinder and closed cryogenic receptacle standards).

5.2.6.4.5 If the periodic inspection and test body is denied approval, the appropriate national authority must provide written detailed reasons for such denial.

5.2.6.4.6 *Modifications to periodic inspection and test body approvals*

5.2.6.4.6.1 Following approval, the periodic inspection and test body must notify the issuing appropriate national authority of any modifications to the information submitted under 5.2.6.4.2 relating to the initial approval.

5.2.6.4.6.2 The modifications must be evaluated in order to determine whether the requirements of the relevant cylinder and closed cryogenic receptacle standards and these Instructions will be satisfied.

5.2.6.4.6.3 An audit in accordance with 5.2.6.3.2 may be required.

5.2.6.4.6.4 The appropriate national authority must accept or reject these modifications in writing, and an amended Approval Certificate must be issued as necessary.

5.2.6.4.7 Upon request, the appropriate national authority must communicate to any other appropriate national authority, information concerning initial approvals, modifications of approvals and withdrawn approvals.

5.2.6.5 *Periodic inspection and test and certification*

5.2.6.5.1 The application of the periodic inspection and test marking to a cylinder and closed cryogenic receptacle must be considered a declaration that the cylinder and closed cryogenic receptacle complies with the applicable cylinder and closed cryogenic receptacle standards and the requirements of these Instructions. The periodic inspection and test body must affix the periodic inspection and test marking, including its registered mark, to each approved cylinder and closed cryogenic receptacle (see 5.2.7.8).

5.2.6.5.2 A record certifying that a cylinder and closed cryogenic receptacle have passed the periodic inspection and test must be issued by the periodic inspection and test body before the cylinder and closed cryogenic receptacle are filled.

5.2.6.6 *Records*

5.2.6.6.1 The periodic inspection and test body must retain records of the periodic inspection and test of cylinders and closed cryogenic receptacles (both passed and failed), including the location of the test facility, for not less than 15 years.

5.2.6.6.2 The owner of the cylinder and closed cryogenic receptacle must retain an identical record until the next periodic inspection and test unless the cylinder and closed cryogenic receptacle are permanently removed from service.

5.2.7 Marking of UN refillable cylinders and closed cryogenic receptacles

Note.— Marking requirements for UN metal hydride storage systems are given in 5.2.9.

5.2.7.1 Refillable UN cylinders and closed cryogenic receptacles must be marked clearly and legibly with certification, operational and manufacturing marks. These marks must be permanently affixed (e.g. stamped, engraved or etched) on the cylinder. The marks must be on the shoulder, top end or neck of the cylinder and closed cryogenic receptacle or on a permanently affixed component of the cylinder and closed cryogenic receptacle (e.g. welded collar or corrosion-resistant plate welded to the outer jacket of a closed cryogenic receptacle). Except for the UN packaging symbol, the minimum size of the marks must be 5 mm for cylinders and closed cryogenic receptacles with a diameter greater than or equal to 140 mm and 2.5 mm for cylinders and closed cryogenic receptacles with a diameter less than 140 mm. The minimum size of the UN packaging symbol must be 10 mm for cylinders and closed cryogenic receptacles with a diameter greater than or equal to 140 mm and 5 mm for cylinders and closed cryogenic receptacles with a diameter less than 140 mm.

5.2.7.2 The following certification marks must be applied:

- a) The UN packaging symbol 

This symbol must not be used for any purpose other than certifying that a packaging complies with the relevant requirements in Chapters 1 to 6;

- b) The technical standard (e.g. ISO 9809-1) used for the design, construction and testing;

- c) The character(s) identifying the country of approval, as indicated by the distinguishing signs of motor vehicles in international traffic;
- d) The identity mark or stamp of the inspection body that is registered with the appropriate national authority of the country authorizing the marking;
- e) The date of the initial inspection, the year (four digits) followed by the month (two digits) separated by a slash (i.e. “/”).

5.2.7.3 The following operational marks must be applied:

- f) The test pressure in bar, preceded by the letters “PH” and followed by the letters “BAR”;
- g) The mass of the empty cylinder and closed cryogenic receptacle including all permanently attached integral parts (e.g. neck ring, foot ring, etc.) in kilograms, followed by the letters “KG”. This mass must not include the mass of valve, valve cap or valve guard, any coating, or porous mass for acetylene. The mass must be expressed to three significant figures rounded up to the last digit. For cylinders and closed cryogenic receptacles of less than 1 kg, the mass must be expressed to two significant figures rounded up to the last digit. In the case of cylinders for UN 1001 **Acetylene, dissolved** and UN 3374 **Acetylene, solvent free**, at least one decimal must be shown after the decimal point and two digits for cylinders of less than 1 kg;
- h) The minimum guaranteed wall thickness of the cylinder in millimetres followed by the letters “MM”. This mark is not required for cylinders with a water capacity less than or equal to 1 litre or for composite cylinders or for closed cryogenic receptacles;
- i) In the case of cylinders for compressed gases, UN 1001 **Acetylene, dissolved**, and UN 3374 **Acetylene, solvent free**, the working pressure in bar, preceded by the letters “PW”. In the case of closed cryogenic receptacles, the maximum allowable working pressure preceded by the letters “MAWP”;
- j) In the case of cylinders for liquefied gases and closed cryogenic receptacles, the water capacity in litres expressed to three significant figures rounded down to the last digit, followed by the letter “L”. If the value of the minimum or nominal water capacity is an integer, the digits after the decimal point may be neglected;
- k) In the case of cylinders for UN 1001 **Acetylene, dissolved**, the total of the mass of the empty receptacle, the fittings and accessories not removed during filling, any coating, the porous mass, the solvent and the saturation gas expressed to three significant figures rounded down to the last digit followed by the letters “KG”. At least one decimal must be shown after the decimal point. For cylinders of less than 1 kg, the mass must be expressed to two significant figures rounded down to the last digit;
- l) In the case of cylinders for UN 3374 **Acetylene, solvent free**, the total of the mass of the empty receptacle, the fittings and accessories not removed during filling, any coating, and the porous mass expressed to three significant figures rounded down to the last digit followed by the letters “KG”. At least one decimal must be shown after the decimal point. For cylinders of less than 1 kg, the mass must be expressed to two significant figures rounded down to the last digit.

5.2.7.4 The following manufacturing marks must be applied:

- m) Identification of the cylinder thread (e.g. 25E). (This mark is not required for closed cryogenic receptacles);
- n) The manufacturer’s mark registered by the appropriate national authority. When the country of manufacture is not the same as the country of approval, then the manufacturer’s mark must be preceded by the character(s) identifying the country of manufacture, as indicated by the distinguishing signs of motor vehicles in international traffic. The country mark and the manufacturer’s mark must be separated by a space or slash;
- o) The serial number assigned by the manufacturer;
- ≠ p) In the case of steel cylinders and closed cryogenic receptacles and composite cylinders and closed cryogenic receptacles with steel liner intended for the transport of gases with a risk of hydrogen embrittlement, the letter “H” showing compatibility of the steel (see ISO 11114-1:2012).

5.2.7.5 The above marks must be placed in three groups:

- a) Manufacturing marks must be the top grouping and must appear consecutively in the sequence given in 5.2.7.4;
- b) The operational marks in 5.2.7.3 must be the middle grouping and the test pressure f) which must be immediately preceded by the working pressure (i) when the latter is required;
- c) Certification marks must be the bottom grouping and must appear in the sequence given in 5.2.7.2.

The following is an example of the markings applied to a cylinder:

m) 25E	n) D MF	o) 765432	p) H	
i) PW200PH	f) 300BAR	g) 62.1KG	j) 50L	h) 5.8MM
 a)	b) ISO 9809-1	c) F	d) IB	e) 2000/12

5.2.7.6 Other marks are allowed in areas other than the side wall, provided they are made in low stress areas and are not of a size and depth that will create harmful stress concentrations. In the case of closed cryogenic receptacles, such marks may be on a separate plate attached to the outer jacket. Such marks must not conflict with required marks.

5.2.7.7 Cylinders of composite construction with limited life must be marked with the letters "FINAL" followed by the expiry date, the year (four digits) and the month (two digits).

5.2.7.8 In addition to the preceding marks, each refillable cylinder and closed cryogenic receptacle that meets the periodic inspection and test requirements of 5.2.4 must be marked indicating:

- the character(s) identifying the country authorizing the body performing the periodic inspection and test. This marking is not required if this body is approved by the appropriate national authority of the country approving manufacture;
- the registered mark of the body authorized by the appropriate national authority for performing the periodic inspection and test;
- the date of the periodic inspection and test, the year (two digits) followed by the month (two digits) separated by a slash (i.e. "/"). Four digits may be used to indicate the year.

The above marks must appear consecutively in the sequence given.

5.2.7.9 For acetylene cylinders, with the agreement of the national authority, the date of the most recent periodic inspection and the stamp of the body performing the periodic inspection and test may be engraved on a ring held on the cylinder by the valve. The ring must be configured so that it can be removed only by disconnecting the valve from the cylinder.

5.2.8 Marking of non-refillable UN cylinders and closed cryogenic receptacles

5.2.8.1 Non-refillable UN cylinders and closed cryogenic receptacles must be marked clearly and legibly with certification and gas or cylinder and closed cryogenic receptacle specific marks. These marks must be permanently affixed (e.g. stencilled, stamped, engraved or etched) on the cylinder. Except when stencilled, the marks must be on the shoulder, top end or neck of the cylinder and closed cryogenic receptacle or on a permanently affixed component of the cylinder and closed cryogenic receptacle (e.g. welded collar). Except for the "UN" mark and the "DO NOT REFILL" mark, the minimum size of the marks must be 5 mm for cylinders and closed cryogenic receptacles with a diameter greater than or equal to 140 mm and 2.5 mm and closed cryogenic receptacles for cylinders with a diameter less than 140 mm. The minimum size of the "UN" mark must be 10 mm for cylinders and closed cryogenic receptacles with a diameter greater than or equal to 140 mm and 5 mm for cylinders and closed cryogenic receptacles with a diameter less than 140 mm. The minimum size of the "DO NOT REFILL" mark must be 5 mm.

5.2.8.2 The marks listed in 5.2.7.2 to 5.2.7.4 must be applied with the exception of g), h) and m). The serial number o) may be replaced by the batch number. In addition, the words "DO NOT REFILL" in letters of at least 5 mm in height are required.

5.2.8.3 The requirements of 5.2.7.5 must apply.

Note.— Non-refillable cylinders and closed cryogenic receptacles may, on account of their size, substitute this marking by a label.

5.2.8.4 Other marks are allowed provided they are made in low stress areas other than the side wall and are not of a size and depth that will create harmful stress concentrations. Such marks must not conflict with required marks.

5.2.9 Marking of UN metal hydride storage systems

5.2.9.1 UN metal hydride storage systems must be marked clearly and legibly with the marks listed in 5.2.9.2. These marks must be permanently affixed (e.g. stamped, engraved, or etched) on the metal hydride storage system. The marks must be on the shoulder, top end or neck of the metal hydride storage system or on a permanently affixed component of the metal hydride storage system. Except for the United Nations packaging symbol, the minimum size of the marks must be:

- 5 mm for metal hydride storage systems with a smallest overall dimension greater than or equal to 140 mm; and
- 2.5 mm for metal hydride storage systems with a smallest overall dimension less than 140 mm.

The minimum size of the United Nations packaging symbol must be:

- 10 mm for metal hydride storage systems with a smallest overall dimension greater than or equal to 140 mm; and
- 5 mm for metal hydride storage systems with a smallest overall dimension less than 140 mm.

5.2.9.2 The following marks must be applied:

- a) The UN packaging symbol 

This symbol must not be used for any purpose other than for certifying that a packaging complies with the relevant requirements in Chapters 1 to 6;

- b) "ISO 16111" (the technical standard used for design, manufacture and testing);
- c) The character(s) identifying the country of approval, as indicated by the distinguishing signs of motor vehicles in international traffic;
- d) The identity mark or stamp of the inspection body that is registered with the appropriate national authority of the country authorizing the marking;
- e) The date of the initial inspection, the year (four digits), followed by the month (two digits) and separated by a slash (i.e. "/");
- f) The test pressure of the cylinder in bar, preceded by the letters "PH" and followed by the letters "BAR";
- g) The rated charging pressure of the metal hydride storage system in bar, preceded by the letters "RCP" and followed by the letters "BAR";
- h) The manufacturer's mark registered by the appropriate national authority. When the country of manufacture is not the same as the country of approval, then the manufacturer's mark must be preceded by the character(s) identifying the country of manufacture, as indicated by the distinguishing signs of motor vehicles in international traffic. The country mark and the manufacturer's mark must be separated by a space or slash;
- i) The serial number assigned by the manufacturer;
- ≠ j) In the case of steel cylinders and composite cylinders with steel liner, the letter "H" showing compatibility of the steel (see ISO 11114-1:2012); and
- k) In the case of metal hydride storage systems having limited life, the date of expiry, denoted by the letters "FINAL" followed by the year (four digits), followed by the month (two digits) and separated by a slash (i.e. "/").

The certification marks specified in a) to e) above must appear consecutively in the sequence given. The test pressure (f) must be immediately preceded by the rated charging pressure (g)). The manufacturing marks specified in h) to k) must appear consecutively in the sequence given.

5.2.9.3 Other marks are allowed in areas other than the side wall, provided they are made in low stress areas and are not of a size and depth that will create harmful stress concentrations. Such marks must not conflict with required marks.

5.2.9.4 In addition to the preceding marks, each metal hydride storage system that meets the periodic inspection and test requirements of 5.2.4 must be marked indicating:

- a) the character(s) identifying the country authorizing the body performing the periodic inspection and test, as indicated by the distinguishing sign of motor vehicles in international traffic. This marking is not required if this body is approved by the appropriate national authority of the country approving manufacture;
- b) the registered mark of the body authorized by the appropriate national authority for performing periodic inspection and test;
- c) the date of the periodic inspection and test, the year (two digits), followed by the month (two digits) and separated by a slash (i.e. "/"). Four digits may be used to indicate the year.

The above marks must appear consecutively in the sequence given.

5.3 REQUIREMENTS FOR NON-UN CYLINDERS AND NON-UN CLOSED CRYOGENIC RECEPTACLES

5.3.1 Cylinders and closed cryogenic receptacles not designed, constructed, inspected, tested and approved according to the requirements of 5.2 must be designed, constructed, inspected, tested and approved in accordance with the provisions of a technical code recognized by the appropriate national authority and the general requirements of 5.1.

5.3.2 Cylinders and closed cryogenic receptacles designed, constructed, inspected, tested and approved under the provisions of this section must not be marked with the UN packaging symbol.

5.3.3 For metallic cylinders, the construction must be such that the minimum burst ratio (burst pressure divided by test pressure) is:

- 1.50 for refillable cylinders,
- 2.00 for non-refillable cylinders.

5.3.4 Marking must be in accordance with the requirements of the appropriate national authority of the country of use.

5.4 REQUIREMENTS FOR AEROSOL DISPENSERS, SMALL RECEPTACLES CONTAINING GAS (GAS CARTRIDGES) AND FUEL CELL CARTRIDGES CONTAINING LIQUEFIED FLAMMABLE GAS

>
+ Each filled aerosol dispenser or gas cartridge or fuel cell cartridge must be subjected to a test in a hot water bath in accordance with 5.4.1 or an approved water bath alternative in accordance with 5.4.2.

≠ 5.4.1 Hot water bath test

≠ 5.4.1.1 The temperature of the water bath and the duration of the test must be such that the internal pressure reaches that which would be reached at 55°C (50°C if the liquid phase does not exceed 95 per cent of the capacity of the aerosol dispenser, gas cartridge or fuel cell cartridge at 50°C). If the contents are sensitive to heat or if the aerosol dispensers, gas cartridges or fuel cell cartridges are made of plastics material which softens at this test temperature, the temperature of the bath must be set at between 20°C and 30°C but, in addition, one aerosol dispenser, gas cartridge or fuel cell cartridge in 2 000 must be tested at the higher temperature.

≠ 5.4.1.2. No leakage or permanent deformation of an aerosol dispenser, gas cartridge or fuel cell cartridge may occur, except that a plastic aerosol dispenser, gas cartridge or fuel cell cartridge may be deformed through softening provided that it does not leak.

≠ 5.4.2 Alternative methods

≠ With the approval of the appropriate national authority, alternative methods which provide an equivalent level of safety may be used provided that the requirements of 5.4.2.1 and, as appropriate, 5.4.2.2 or 5.4.2.3 are met.

≠ 5.4.2.1 Quality system

≠ 5.4.2.1.1 Aerosol dispenser, gas cartridge or fuel cell cartridge fillers and component manufacturers must have a quality system. The quality system must implement procedures to ensure that all aerosol dispensers, gas cartridges or fuel cell cartridges that leak or that are deformed are rejected and not offered for transport.

≠ 5.4.2.1.1.1 The quality system must include:

- a) a description of the organizational structure and responsibilities;
- b) the relevant inspection and test, quality control, quality assurance, and process operation instructions that will be used;
- c) quality records, such as inspection reports, test data, calibration data and certificates;
- d) management reviews to ensure the effective operation of the quality system;
- e) a process for control of documents and their revision;
- ≠ f) a means for control of non-conforming aerosol dispensers, gas cartridges or fuel cell cartridges;
- g) training programmes and qualification procedures for relevant personnel; and
- h) procedures to ensure that there is no damage to the final product.

≠ 5.4.2.1.2 An initial audit and periodic audits must be conducted to the satisfaction of the appropriate national authority. These audits must ensure the approved system is and remains adequate and efficient. Any proposed changes to the approved system must be notified to the appropriate national authority in advance.

+ 5.4.2.2 *Aerosol dispensers*

≠ 5.4.2.2.1 *Pressure and leak testing of aerosol dispensers before filling*

≠ Each empty aerosol dispenser must be subjected to a pressure equal to or in excess of the maximum expected in the filled aerosol dispensers at 55°C (50°C if the liquid phase does not exceed 95 percent of the capacity of the receptacle at 50°C). This must be at least two-thirds of the design pressure of the aerosol dispenser. If any aerosol dispenser shows evidence of leakage at a rate equal to or greater than 3.3×10^{-2} mbar.l.s⁻¹ at the test pressure, distortion or other defect, it must be rejected.

≠ 5.4.2.2.2 *Testing of the aerosol dispensers after filling*

≠ 5.4.2.2.2.1 Prior to filling, the filler must ensure that the crimping equipment is set appropriately and the specified propellant is used.

≠ 5.4.2.2.2.2 Each filled aerosol dispenser must be weighed and leak tested. The leak detection equipment must be sufficiently sensitive to detect at least a leak rate of 2.0×10^{-3} mbar.l.s⁻¹ at 20°C.

≠ 5.4.2.2.3 Any filled aerosol dispenser which shows evidence of leakage, deformation or excessive mass must be rejected.

+ 5.4.2.3 *Gas cartridges and fuel cell cartridges*

+ 5.4.2.3.1 *Pressure testing of gas cartridges and fuel cell cartridges*

+ 5.4.2.3.1.1 Each gas cartridge or fuel cell cartridge must be subjected to a test pressure equal to or in excess of the maximum expected in the filled receptacle at 55°C (50°C if the liquid phase does not exceed 95 per cent of the capacity of the receptacle at 50°C). This test pressure must be that specified for the gas cartridge or fuel cell cartridge and must not be less than two thirds the design pressure of the gas cartridge or fuel cell cartridge. If any gas cartridge or fuel cell cartridge shows evidence of leakage at a rate equal to or greater than 3.3×10^{-2} mbar.l.s⁻¹ at the test pressure, distortion or any other defect, it must be rejected.

+ 5.4.2.3.2 *Leak testing gas cartridges and fuel cell cartridges*

+ 5.4.2.3.2.1 Prior to filling and sealing, the filler must ensure that the closures (if any) and the associated sealing equipment are closed appropriately and the specified gas is used.

+ 5.4.2.3.2.2 Each filled gas cartridge or fuel cell cartridge must be checked for the correct mass of gas and must be leak tested. The leak detection equipment must be sufficiently sensitive to detect at least a leak rate of 2.0×10^{-3} mbar.l.s⁻¹ at 20°C.

+ 5.4.2.3.2.3 Any gas cartridge or fuel cell cartridge that has a gas mass not in conformity with the declared mass limits or shows evidence of leakage or deformation, must be rejected.

5.4.3 With the approval of the appropriate national authority, aerosols and receptacles, small, are not subject to 5.4.1 and 5.4.2 if they are required to be sterile, but may be adversely affected by water bath testing, provided:

a) they contain a non-flammable gas and either:

- i) contain other substances that are constituent parts of pharmaceutical products for medical, veterinary or similar purposes; or
- ii) contain other substances used in the production process for pharmaceutical products; or
- iii) are used in medical, veterinary or similar applications;

b) an equivalent level of safety is achieved by the manufacturer's use of alternative methods for leak detection and pressure resistance, such as helium detection and water bathing using a statistical sample of at least 1 in 2 000 from each production batch; and

c) for pharmaceutical products according to a) i) and iii) above, they are manufactured under the authority of a national health administration. If required by the appropriate national authority, the principles of Good Manufacturing Practice (GMP) established by the World Health Organization (WHO)¹ must be followed.

1. WHO Publication: Quality assurance of pharmaceuticals. A compendium of guidelines and related materials. Volume 2: Good manufacturing practices and inspection.

Chapter 6

PACKAGINGS FOR INFECTIOUS SUBSTANCES OF CATEGORY A

6.1 GENERAL

The requirements of this chapter apply to packagings intended for the transport of infectious substances of Category A.

6.2 REQUIREMENTS FOR PACKAGINGS

6.2.1 The requirements for packagings in this section are based on packagings, as specified in Chapter 2, currently used. In order to take into account progress in science and technology, there is no objection to the use of packagings having specifications different from those in this chapter provided that they are equally effective, acceptable to the competent authority and able successfully to withstand the tests described in 6.5. Methods of testing other than those described in these Instructions are acceptable provided they are equivalent.

6.2.2 Packagings must be manufactured and tested under a quality assurance programme which satisfies the competent authority in order to ensure that each packaging meets the requirements of this chapter.

6.2.3 Manufacturers and subsequent distributors of packagings must provide information regarding procedures to be followed (including closure instructions for inner packagings and receptacles), a description of the types and dimensions of the closures (including required gaskets) and any other components needed to ensure that packages, as presented for transport, are capable of passing the applicable performance tests of this chapter.

6.3 CODE FOR DESIGNATING TYPES OF PACKAGINGS

6.3.1 The codes for designating types of packagings are set out in 6;1.2.

6.3.2 The letters "U" or "W" may follow the packaging code. The letter "U" signifies a special packaging conforming to the requirements of 6.5.1.6. The letter "W" signifies that the packaging, although of the same type indicated by the code, is manufactured to a specification different from that in Chapter 3 and is considered equivalent under the requirements of 6.2.1.

6.4 MARKING

Note 1.— The marking indicates that the packaging which bears it corresponds to a successfully tested design type and that it complies with the provisions of this chapter which are related to the manufacture, but not to the use, of the packaging.

Note 2.— The marking is intended to be of assistance to packaging manufacturers, reconditioners, packaging users, operators and appropriate authorities.

Note 3.— The marking does not always provide full details of the test levels, etc., and these may need to be taken further into account, e.g. by reference to a test certificate, test reports or register of successfully tested packagings.

6.4.1 Each packaging intended for use according to these Instructions must bear markings which are durable, legible and placed in a location and of such a size relative to the packaging as to be readily visible. For packages with a gross mass of more than 30 kg the markings, or a duplicate thereof, must appear on the top or on a side of the packaging. Letters, numerals and symbols must be at least 12 mm high, except for packagings of 30 L or 30 kg capacity or less, when they must be at least 6 mm in height and for packagings of 5 L or 5 kg or less, when they must be of an appropriate size.

6.4.2 A packaging that meets the requirements of this section and of 6.5 shall be marked with:

- a) the United Nations packaging symbol; 

This symbol must not be used for any purpose other than certifying that a packaging complies with the relevant requirements in Chapters 1 to 6;

- b) the code designating the type of packaging according to the requirements of 6;1.2;
c) the text "CLASS 6.2";

- d) the last two digits of the year of manufacture of the packaging;
- e) the State authorizing the allocation of the mark, indicated by the distinguishing sign for motor vehicles in international traffic;
- f) the name of the manufacturer or other identification of the packaging specified by the competent authority; and
- g) for packagings meeting the requirements of 6.5.1.6, the letter “U”, inserted immediately following the marking required in b) above.

6.4.3 Markings must be applied in the sequence of the sub-paragraphs in 6.4.2; each element of the marking required in these sub-paragraphs must be clearly separated, e.g. by a slash or space, so as to be easily identified. For an example see 6.4.4. Any additional markings authorized by a competent authority must still enable the parts of the marking to be correctly identified with reference to 6.4.1.

6.4.4 Example of a marking:

	4G/CLASS 6.2/06 S/SP-9989-ERIKSSON	as in 6.4.2 a), b), c) and d) as in 6.4.2 e) and f)
---	---------------------------------------	--

6.5 TEST REQUIREMENTS FOR PACKAGINGS

6.5.1 Performance and frequency of tests

6.5.1.1 The design type of each packaging must be tested as provided for in this chapter in accordance with procedures established by the competent authority.

6.5.1.2 Each packaging design type must successfully pass the tests prescribed in this chapter before being used. A packaging design type is defined by the design, size, material and thickness, manner of construction and packing, but may include various surface treatments. It also includes packagings which differ from the design type only in their lesser design height.

6.5.1.3 Tests must be repeated on production samples at intervals established by the competent authority.

6.5.1.4 Tests must also be repeated after each modification which alters the design, material or manner of construction of a packaging.

6.5.1.5 The competent authority may permit the selective testing of packagings that differ only in minor respects from a tested type, e.g. smaller sizes or lower net mass of primary receptacles; and packagings such as drums and boxes which are produced with small reductions in external dimension(s).

6.5.1.6 Primary receptacles of any type may be assembled within a secondary packaging and transported without testing in the rigid outer packaging under the following conditions:

- a) The rigid outer packaging combination must have been successfully tested in accordance with 6.5.2.2 with fragile (e.g. glass) primary receptacles.
- b) The total combined gross mass of primary receptacles must not exceed one-half the gross mass of primary receptacles used for the drop test in a) above.
- c) The thickness of cushioning between primary receptacles and between primary receptacles and the outside of the secondary packaging must not be reduced below the corresponding thicknesses in the originally tested packaging; and if a single primary receptacle was used in the original test, the thickness of cushioning between primary receptacles must not be less than the thickness of cushioning between the outside of the secondary packaging and the primary receptacle in the original test. When either fewer or smaller primary receptacles are used (as compared to the primary receptacles used in the drop test), sufficient additional cushioning material must be used to take up the void spaces.
- d) The rigid outer packaging must have successfully passed the stacking test in 4.6 while empty. The total mass of identical packages must be based on the combined mass of packagings used in the drop test in a) above.
- e) For primary receptacles containing liquids, an adequate quantity of absorbent material to absorb the entire liquid content of the primary receptacles must be present.
- f) If the rigid outer packaging is intended to contain primary receptacles for liquids and is not leakproof, or is intended to contain primary receptacles for solids and is not siftproof, a means of containing any liquid or solid contents in the event of leakage must be provided in the form of a leakproof liner, plastic bag or other equally effective means of containment.
- g) In addition to the markings prescribed in 6.4.2 a) to f), packagings must be marked in accordance with 6.4.2 g).

6.5.1.7 The competent authority may at any time require proof, by tests in accordance with this chapter, that serially produced packagings meet the requirements of the design type tests.

6.5.1.8 Provided the validity of the test results is not affected, and with the approval of the competent authority, several tests may be made on one sample.

6.5.2 Preparation of packagings for testing

6.5.2.1 Samples of each packaging must be prepared as for transport except that the liquid or solid infectious substance must be replaced by water or, where conditioning at -18°C is specified, by a water/antifreeze mixture. Each primary receptacle must be filled to not less than 98 per cent of its capacity.

Note.— The term water includes water/antifreeze solution with a minimum specific gravity of 0.95 for testing at -18°C .

6.5.2.2 Tests and number of samples required

Table 6-4. Tests required for packaging types

Type of packaging ^a	Tests required							
	Primary receptacle		Water spray 6.5.3.6.1	Cold conditioning 6.5.3.6.2	Drop 6.5.3	Additional drop 6.5.3.6.3	Puncture 6.5.4	Stacking 6;4.6
	Rigid outer packaging	Plastics	Other	No. of samples	No. of samples	No. of samples	No. of samples	No. of samples
Fibreboard box	X		5	5	10		2	
			X	5	0	5	2	
Fibreboard drum	X		3	3	6		2	
			X	3	0	3	2	
Plastics box	X		0	5	5	Required on one sample when the packaging is intended to contain dry ice.	2	Required on three samples when testing a "U"-marked packaging, as defined in 6.5.1.6 for specific provisions.
			X	0	5		2	
Plastics drum/jerrican	X		0	3	3		2	
			X	0	3		2	
Boxes of other material	X		0	5	5		2	
			X	0	0		5	
Drums/jerricans of other material	X		0	3	3		2	
			X	0	0	3	2	

a. *Type of packaging* categorizes packagings for test purposes according to the kind of packaging and its material characteristics.

Note 1.— In instances where a primary receptacle is made of two or more materials, the material most liable to damage determines the appropriate test.

Note 2.— The material of the secondary packagings are not taken into consideration when selecting the test or conditioning for the test.

6.5.2.2.1 Explanation for use of Table 6-4

6.5.2.2.1.1 If the packaging to be tested consists of a fibreboard outer box with a plastics primary receptacle, five samples must undergo the water spray test (see 6.5.3.6.1) prior to dropping and another five must be conditioned to -18°C (see 6.5.3.6.2) prior to dropping. If the packaging is to contain dry ice, then one further single sample must be dropped five times after conditioning in accordance with 6.5.3.6.3.

6.5.2.2.1.2 Packagings prepared as for transport must be subjected to the tests in 6.5.3 and 6.5.4. For outer packagings, the headings in Table 6-4 relate to fibreboard or similar materials whose performance may be rapidly affected by moisture, plastics which may embrittle at low temperature, and other materials such as metal whose performance is not affected by moisture or temperature.

6.5.3 Drop test

6.5.3.1 Samples must be subjected to free-fall drops from a height of 9 metres onto a non-resilient, horizontal, flat, massive and rigid surface in conformity with 6.4.3.4.

6.5.3.2 Where the samples are in the shape of a box, five must be dropped, one in each of the following orientations:

- a) flat on the base;
- b) flat on the top;
- c) flat on the longest side;
- d) flat on the shortest side;
- e) on a corner.

6.5.3.3 Where the samples are in the shape of a drum, three must be dropped, one in each of the following orientations:

- a) diagonally on the top chime, with the centre of gravity directly above the point of impact;
- b) diagonally on the base chime;
- c) flat on the side.

6.5.3.4 While the sample must be released in the required orientation, it is accepted that for aerodynamic reasons the impact may not take place in that orientation.

6.5.3.5 Following the appropriate drop sequence, there must be no leakage from the primary receptacle(s), which must remain protected by cushioning/absorbent material in the secondary packaging.

6.5.3.6 *Special preparation of test sample for the drop test*

6.5.3.6.1 *Fibreboard — water spray test*

Fibreboard outer packagings: The sample must be subjected to a water spray that simulates exposure to rainfall of approximately 5 cm per hour for at least one hour. It must then be subjected to the test described in 6.5.3.1.

6.5.3.6.2 *Plastics material — cold conditioning*

Plastics primary receptacles or outer packagings: The temperature of the test sample and its contents must be reduced to -18°C or lower for a period of at least 24 hours and within 15 minutes of removal from that atmosphere the test sample must be subjected to the test described in 6.5.3.1. Where the sample contains dry ice, the conditioning period may be reduced to four hours.

6.5.3.6.3 *Packagings intended to contain dry ice — additional drop test*

Where the packaging is intended to contain dry ice, a test additional to that specified in 6.5.3.1 and, when appropriate, in 6.5.3.6.1 or 6.5.3.6.2 must be carried out. One sample must be stored so that all the dry ice dissipates and then that sample must be dropped in one of the orientations described in 6.5.3.2 which must be that most likely to result in failure of the packaging.

6.5.4 Puncture test

6.5.4.1 *Packagings with a gross mass of 7 kg or less*

Samples must be placed on a level, hard surface. A cylindrical steel rod with a mass of at least 7 kg, a diameter of 38 mm and the impact end edges of a radius not exceeding 6 mm (see Figure 6-3) must be dropped in a vertical free fall from a height of one metre measured from the impact end to the impact surface of the sample. One sample must be placed on its base. A second sample must be placed in an orientation perpendicular to that used for the first sample. In each instance, the steel rod must be aimed to impact the primary receptacle. Following each impact, penetration of the secondary packaging is acceptable, provided that there is no leakage from the primary receptacle(s).

6.5.4.2 *Packagings with a gross mass exceeding 7 kg*

Samples are dropped onto the end of a cylindrical steel rod. The rod must be set vertically on a level, hard surface. It must have a diameter of 38 mm with the upper end edges of a radius not exceeding 6 mm (see Figure 6-3). The rod must protrude from the surface a distance at least equal to the distance between the centre of the primary receptacle(s) and the outer surface of the outer packaging, with a minimum protrusion of 200 mm. One sample is dropped with its top face lowermost in a vertical free fall from a height of 1 m, measured from the top of the steel rod. A second sample is dropped from the same height in an

orientation perpendicular to that used for the first sample. In each instance, the packaging must be so orientated that the steel rod would be capable of penetrating the primary receptacle(s). Following each impact, penetration of the secondary packaging is acceptable provided that there is no leakage from the primary receptacle(s).

6.5.5 Test report

6.5.5.1 A written test report containing at least the following particulars must be prepared and must be available to the users of the packaging:

- a) name and address of the test facility;
- b) name and address of the applicant (where appropriate);
- c) a unique test report identification;
- d) date of the test and of the report;
- e) manufacturer of the packaging;
- f) description of the packaging design type (e.g. dimensions, materials, closures, thickness, etc.), including method of manufacture (e.g. blow moulding) and which may include drawing(s) and/or photograph(s);
- g) maximum capacity;
- h) test contents;
- i) test descriptions and results;
- j) a signature and the name and status of the signatory.

6.5.5.2 The test report must contain statements that the packaging prepared for transport was tested in accordance with the appropriate requirements of this chapter and that the use of other packaging methods or components may render it invalid. A copy of the test report must be available to the appropriate national authority.

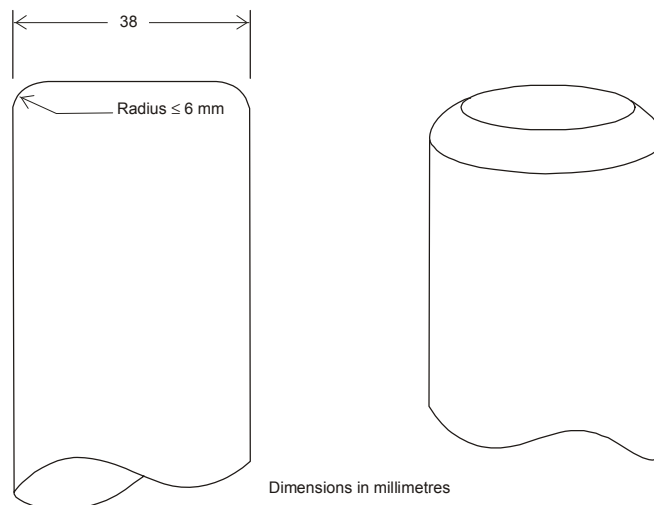

Figure 6-3. Cylindrical steel rod used for puncture test

Chapter 7

≠

REQUIREMENTS FOR THE CONSTRUCTION, TESTING AND APPROVAL OF PACKAGES FOR RADIOACTIVE MATERIAL AND FOR THE APPROVAL OF SUCH MATERIAL

Parts of this Chapter are affected by State Variations CA 1, CA 3, CA 4, DE 2, IR 4, JP 8, US 10; see Table A-1

7.1 GENERAL REQUIREMENTS

≠ 7.1.1 The package must be so designed in relation to its mass, volume and shape that it can be easily and safely transported. In addition, the package must be so designed that it can be properly secured in the aircraft during transport.

7.1.2 The design must be such that any lifting attachments on the package will not fail when used in the intended manner and that, if failure of the attachments should occur, the ability of the package to meet other requirements of these Instructions would not be impaired. The design must take account of appropriate safety factors to cover snatch lifting.

7.1.3 Attachments and any other features on the outer surface of the package which could be used to lift it must be designed either to support its mass in accordance with the requirements of 7.1.2 or must be removable or otherwise rendered incapable of being used during transport.

7.1.4 As far as practicable, the packaging must be designed and finished so that the external surfaces are free from protruding features and can be easily decontaminated.

7.1.5 As far as practicable, the outer layer of the package must be designed so as to prevent the collection and the retention of water.

7.1.6 Any features added to the package at the time of transport which are not part of the package must not reduce its safety.

7.1.7 The package must be capable of withstanding the effects of any acceleration, vibration or vibration resonance, which may arise under routine conditions of transport without any deterioration in the effectiveness of the closing devices on the various receptacles or in the integrity of the package as a whole. In particular, nuts, bolts and other securing devices must be designed so as to prevent them from becoming loose or being released unintentionally, even after repeated use.

7.1.8 The materials of the packaging and any components or structures must be physically and chemically compatible with each other and with the radioactive contents. Account must be taken of their behaviour under irradiation.

7.1.9 All valves through which the radioactive contents could escape must be protected against unauthorized operation.

7.1.10 The design of the package must take into account ambient temperatures and pressures that are likely to be encountered in routine conditions of transport.

+ 7.1.11 A package must be so designed that it provides sufficient shielding to ensure that, under routine conditions of transport and with the maximum radioactive contents that the package is designed to contain, the radiation level at any point on the external surface of the package would not exceed the values specified in 2;7.2.4.1.1.2, 4;9.1.10 and 4;9.1.11, as applicable, with account taken of 7;2.10.3.3 c).

≠ 7.1.12 For radioactive material having other dangerous properties, the package design must take into account those properties (see Part 2, Introductory Chapter, 3.1, 3.2 and 4;9.1.5).

7.2 ADDITIONAL REQUIREMENTS FOR PACKAGES TRANSPORTED BY AIR

7.2.1 The temperature of the accessible surfaces must not exceed 50°C at an ambient temperature of 38°C with no account taken of insolation.

7.2.2 Packages must be designed so that, if they were exposed to ambient temperatures ranging from -40°C to +55°C, the integrity of the containment would not be impaired.

- ≠ 7.2.3 Packages containing radioactive material must be capable of withstanding, without loss or dispersal of radioactive contents from the containment system, an internal pressure that produces a pressure differential of not less than maximum normal operating pressure plus 95 kPa.

7.3 REQUIREMENTS FOR EXCEPTED PACKAGES

An excepted package must be designed to meet the requirements specified in 7.1 and 7.2.

7.4 REQUIREMENTS FOR INDUSTRIAL PACKAGES

7.4.1 Industrial packages Types 1, 2 and 3 (Types IP-1, IP-2 and IP-3) must meet the requirements specified in 7.1, 7.2 and 7.6.2.

7.4.2 A Type IP-2 package must, if it were subjected to the tests specified in 7.14.4 and 7.14.5, prevent:

- a) loss or dispersal of the radioactive contents; and
- b) more than a 20 per cent increase in the maximum radiation level at any external surface of the package.

7.4.3 A Type IP-3 package must meet all the requirements specified in 7.6.2 to 7.6.15.

7.4.4 Alternative requirements for industrial packages Types 2 and 3 (Types IP-2 and IP-3)

7.4.4.1 Packages may be used as a Type IP-2 package, provided that:

- a) they satisfy the requirements of 7.4.1;
- b) they are designed to satisfy the requirements prescribed for Packing Group I or II in Part 6, Chapters 1 to 4, of these Instructions; and
- c) when subjected to the tests required for Packing Group I or II in Part 6, Chapter 4, they would prevent:
 - i) loss or dispersal of the radioactive contents; and
 - ii) more than a 20 per cent increase in the maximum radiation level at any external surface of the package.

7.4.4.2 Freight containers with the characteristics of a permanent enclosure may also be used as Industrial package Type 2 or 3 (Type IP-2 or IP-3), provided that:

- a) the radioactive contents are restricted to solid materials;
- b) they satisfy the requirements of 7.4.1; and
- c) they are designed to conform to ISO 1496-1:1990: "Series 1 freight containers — Specification and testing — Part 1: General cargo containers" and subsequent amendments 1:1993, 2:1998, 3:2005, 4:2006 and 5:2006, excluding dimensions and ratings. They must be designed so that, if subjected to the tests prescribed in that document and to the accelerations occurring during routine conditions of transport, they would prevent:
 - i) loss or dispersal of the radioactive contents; and
 - ii) more than a 20 per cent increase in the maximum radiation level at any external surface of the freight containers.

7.5 REQUIREMENTS FOR PACKAGES CONTAINING URANIUM HEXAFLUORIDE

- ≠ 7.5.1 Packages designed to contain uranium hexafluoride must meet the requirements which pertain to the radioactive and fissile properties of the material prescribed elsewhere in these Instructions. Except as allowed in 7.5.4, uranium hexafluoride in quantities of 0.1 kg or more must also be packaged and transported in accordance with the provisions of ISO 7195:2005: "Nuclear Energy — Packaging of uranium hexafluoride (UF₆) for transport", and the requirements of 7.5.2 and 7.5.3. The package must also meet the requirements prescribed elsewhere in these Instructions, which pertain to the radioactive and fissile properties of the material.

7.5.2 Each package designed to contain 0.1 kg or more of uranium hexafluoride must be designed so that it would meet the following requirements:

- ≠ a) withstand, without leakage and without unacceptable stress, as specified in ISO 7195:2005, the structural test as specified in 7.20 except as allowed in 7.5.4;
- b) withstand, without loss or dispersal of the uranium hexafluoride, the free drop test specified in 7.14.4; and
- ≠ c) withstand, without rupture of the containment system, the thermal test specified in 7.16.3 except as allowed in 7.5.4.

7.5.3 Packages designed to contain 0.1 kg or more of uranium hexafluoride must not be provided with pressure relief devices.

- ≠ 7.5.4 Subject to the multilateral approval, packages designed to contain 0.1 kg or more of uranium hexafluoride may be transported if the packages are designed:

- ≠ a) to international or national standards other than ISO 7195:2005 provided an equivalent level of safety is maintained; and/or
- ≠ b) to withstand, without leakage and without unacceptable stress, a test pressure of less than 2.76 MPa, as specified in 7.20; and/or
- ≠ c) to contain 9 000 kg or more of uranium hexafluoride and the packages do not meet the requirement of 7.5.2 c).

In all other respects, the requirements specified in 7.5.1 to 7.5.3 must be satisfied.

7.6 REQUIREMENTS FOR TYPE A PACKAGES

7.6.1 Type A packages must be designed to meet the requirements of 7.1, 7.2 and 7.6.2 to 7.6.17.

7.6.2 The smallest overall external dimension of the package must not be less than 10 cm.

7.6.3 The outside of the package must incorporate a feature such as a seal, which is not readily breakable and which, while intact, will be evidence that it has not been opened.

7.6.4 Any tie-down attachments on the package must be designed so that, under normal and accident conditions of transport, the forces in those attachments must not impair the ability of the package to meet the requirements of these Instructions.

7.6.5 The design of the package must take into account temperatures ranging from -40°C to $+70^{\circ}\text{C}$ for the components of the packaging. Attention must be given to freezing temperatures for liquids and to the potential degradation of packaging materials within the given temperature range.

7.6.6 The design and manufacturing techniques must be in accordance with national or international standards, or other requirements, acceptable to the competent authority.

7.6.7 The design must include a containment system securely closed by a positive fastening device which cannot be opened unintentionally or by a pressure which may arise within the package.

7.6.8 Special form radioactive material may be considered as a component of the containment system.

7.6.9 If the containment system forms a separate unit of the package, it must be capable of being securely closed by a positive fastening device which is independent of any other part of the packaging.

7.6.10 The design of any component of the containment system must take into account, where applicable, the radiolytic decomposition of liquids and other vulnerable materials and the generation of gas by chemical reaction and radiolysis.

7.6.11 The containment system must retain its radioactive contents under a reduction of ambient pressure to 60 kPa.

7.6.12 All valves, other than pressure relief valves, must be provided with an enclosure to retain any leakage from the valve.

7.6.13 A radiation shield, which encloses a component of the package specified as a part of the containment system, must be designed so as to prevent the unintentional release of that component from the shield. Where the radiation shield and such component within it form a separate unit, the radiation shield must be capable of being securely closed by a positive fastening device, which is independent of any other packaging structure.

7.6.14 A package must be designed so that if it were subjected to the tests specified in 7.14, it would prevent:

- a) loss or dispersal of the radioactive contents; and
- b) more than a 20 per cent increase in the maximum radiation level at any external surface of the package.

7.6.15 The design of a package intended for liquid radioactive material must make provision for ullage to accommodate variations in the temperature of the contents, dynamic effects and filling dynamics.

7.6.16 Type A packages to contain liquids

A Type A package designed to contain liquid radioactive material must, in addition:

- a) be adequate to meet the conditions specified in 7.6.14 a) if the package is subjected to the tests specified in 7.15; and
- b) either:
 - i) be provided with sufficient absorbent material to absorb twice the volume of the liquid contents. Such absorbent material must be suitably positioned so as to contact the liquid in the event of leakage; or
 - ii) be provided with a containment system composed of primary inner and secondary outer containment components, designed to enclose the liquid contents completely and ensure their retention within the secondary outer containment components, even if the primary inner components leak.

7.6.17 Type A packages to contain gas

A package designed for gases must prevent loss or dispersal of the radioactive contents if the package were subjected to the tests specified in 7.15. A Type A package designed for tritium gas or for noble gases must be excepted from this requirement.

7.7 REQUIREMENTS FOR TYPE B(U) PACKAGES

7.7.1 Type B(U) packages must be designed to meet the requirements specified in 7.1, 7.2 and 7.6.2 to 7.6.15, except 7.6.14 a), and, in addition, to the requirements specified in 7.7.2 to 7.7.15.

- ≠ 7.7.2 A package must be designed so that, under the ambient conditions specified in 7.7.5 and 7.7.6, heat generated within the package by the radioactive contents does not, under normal conditions of transport, as demonstrated by the tests in 7.14, adversely affect the package in such a way that it would fail to meet the applicable requirements for containment and shielding if left unattended for a period of one week. Particular attention must be paid to the effects of heat, which may cause one or more of the following:
 - ≠ a) alter the arrangement, the geometrical form or the physical state of the radioactive contents or, if the radioactive material is enclosed in a can or receptacle (for example, clad fuel elements), cause the can, receptacle or radioactive material to deform or melt;
 - ≠ b) lessen the efficiency of the packaging through differential thermal expansion or cracking or melting of the radiation shielding material;
 - c) in combination with moisture, accelerate corrosion.

7.7.3 A package must be so designed that, under the ambient condition specified in 7.7.5 and in the absence of isolation, the temperature of the accessible surfaces of a package must not exceed 50°C, unless the package is transported under exclusive use.

7.7.4 In order to meet the requirements of 7.2.1, account may be taken of barriers or screens intended to give protection to persons without the need for the barriers or screens being subject to any test.

7.7.5 The ambient temperature must be assumed to be 38°C.

7.7.6 The solar insolation conditions must be assumed to be as specified in Table 6-5.

7.7.7 A package which includes thermal protection for the purpose of satisfying the requirements of the thermal test specified in 7.16.3 must be so designed that such protection will remain effective if the package is subjected to the tests specified in 7.14 and 7.16.2 a) and b) or 7.16.2 b) and c), as appropriate. Any such protection on the exterior of the package must not be rendered ineffective by ripping, cutting, skidding, abrasion or rough handling.

7.7.8 A package must be so designed that, if it were subjected to:

- a) the tests specified in 7.14, it would restrict the loss of radioactive contents to not more than $10^{-6} A_2$ per hour; and
- ≠ b) the tests specified in 7.16.1, 7.16.2 b), 7.16.3 and 7.16.4 and either the tests in:
- i) 7.16.2 c), when the package has a mass not greater than 500 kg, an overall density not greater than 1 000 kg/m³ based on the external dimensions, and radioactive contents greater than 1 000 A₂ not as special form radioactive material; or
 - ii) 7.16.2 a), for all other packages,

it would meet the following requirements:

- retain sufficient shielding to ensure that the radiation level at 1 m from the surface of the package would not exceed 10 mSv/h with the maximum radioactive contents which the package is designed to contain; and
- restrict the accumulated loss of radioactive contents in a period of one week to not more than 10 A₂ for krypton-85 and not more than A₂ for all other radionuclides.

Where mixtures of different radionuclides are present, the provisions of 2;7.2.2.4 to 2;7.2.2.6 must apply except that for krypton-85, an effective A₂(i) value equal to 10 A₂ may be used. For case a) above, the assessment must take into account the external contamination limits of 4;9.1.2.

Table 6-5. Insolation data

Case	Form and location of surface	Insolation for 12 hours per day (W/m ²)
1	Flat surfaces transported horizontally — downward facing	0
2	Flat surfaces transported horizontally — upward facing	800
3	Surfaces transported vertically	200*
4	Other downward facing (not horizontal) surfaces	200*
5	All other surfaces	400*

* Alternatively, a sine function may be used, with an absorption coefficient adopted and the effects of possible reflection from neighbouring objects neglected.

7.7.9 A package for radioactive contents with activity greater than $10^5 A_2$ must be designed so that if it were subjected to the enhanced water immersion test specified in 7.17, there would be no rupture of the containment system.

7.7.10 Compliance with the permitted activity release limits must depend neither upon filters nor upon a mechanical cooling system.

7.7.11 A package must not include a pressure relief system from the containment system, which would allow the release of radioactive material to the environment under the conditions of the tests specified in 7.14 and 7.16.

7.7.12 A package must be designed so that if it were at the maximum normal operating pressure and it were subjected to the tests specified in 7.14 and 7.16, the level of strains in the containment system would not attain values which would adversely affect the package in such a way that it would fail to meet the applicable requirements.

7.7.13 A package must not have a maximum normal operating pressure in excess of a gauge pressure of 700 kPa.

7.7.14 A package containing low dispersible radioactive material must be so designed so that any features added to the low dispersible radioactive material that are not part of it, or any internal components of the packaging must not adversely affect the performance of the low dispersible radioactive material.

7.7.15 A package must be designed for an ambient temperature range from -40°C to $+38^{\circ}\text{C}$.

7.8 REQUIREMENTS FOR TYPE B(M) PACKAGES

≠ Type B(M) packages must meet the requirements for Type B(U) packages specified in 7.7.1, except that for packages to be transported solely within a specified country or solely between specified countries, conditions other than those given in 7.6.5, 7.7.4 to 7.7.6 and 7.7.9 to 7.7.15 may be assumed with the approval of the competent authorities of these countries. Notwithstanding, the requirements for Type B(U) packages specified in 7.7.4 and 7.7.9 to 7.7.15 must be met as far as practicable.

7.9 REQUIREMENTS FOR TYPE C PACKAGES

7.9.1 Type C packages must be designed to meet the requirements specified in 7.1, 7.2 and 7.6.2 to 7.6.15, except as specified in 7.6.14 a), and the requirements specified in 7.7.2 to 7.7.6, 7.7.10 to 7.7.15 and 7.9.2 to 7.9.4.

7.9.2 A package must be capable of meeting the assessment criteria prescribed for tests in 7.7.8 b) and 7.7.12 after burial in an environment defined by a thermal conductivity of 0.33 W/(m.K) and a temperature of 38°C in the steady state. Initial conditions for the assessment must assume that any thermal insulation of the package remains intact, the package is at the maximum normal operating pressure and the ambient temperature is 38°C.

7.9.3 A package must be designed so that, if it were at the maximum normal operating pressure and subjected to:

- a) the tests specified in 7.14, it would restrict the loss of radioactive contents to not more than $10^{-6} A_2$ per hour; and
- ≠ b) the test sequences in 7.19.1, it would:
 - i) retain sufficient shielding to ensure that the radiation level at 1 m from the surface of the package would not exceed 10 mSv/h with the maximum radioactive contents which the package is designed to contain; and
 - ii) restrict the accumulated loss of radioactive contents in a period of one week to not more than 10 A_2 for krypton-85 and not more than A_2 for all other radionuclides.

Where mixtures of different radionuclides are present, the provisions of 2;7.2.2.4 to 2;7.2.2.6 must apply, except that for krypton-85 an effective $A_2(i)$ value equal to 10 A_2 may be used. For case a) above, the assessment must take into account the external contamination limits of 4;9.1.2.

7.9.4 A package must be so designed that there will be no rupture of the containment system following performance of the enhanced water immersion test specified in 7.17.

7.10 REQUIREMENTS FOR PACKAGES CONTAINING FISSILE MATERIAL

7.10.1 Fissile material must be transported so as to:

- ≠ a) maintain subcriticality during routine, normal and accident conditions of transport; in particular, the following contingencies must be considered:
 - i) water leaking into or out of packages;
 - ii) the loss of efficiency of built-in neutron absorbers or moderators;
 - iii) rearrangement of the contents either within the package or as a result of loss from the package;
 - iv) reduction of spaces within or between packages;
 - v) packages becoming immersed in water or buried in snow; and
 - vi) temperature changes; and
- b) meet the requirements:
 - ≠ i) of 7.6.2;
 - ≠ ii) prescribed elsewhere in these Instructions and which pertain to the radioactive properties of the material;
 - ≠ iii) of 7.6.3, unless the material is excepted by 2;7.2.3.5; and
 - + iv) of 7.10.4 to 7.10.14, unless the material is excepted by 2;7.2.3.5, 7.10.2 or 7.10.3.

≠ 7.10.2 Packages containing fissile material that meet the provisions of subparagraph d) and one of the provisions of a) to c) below are excepted from the requirements of 7.10.4 to 7.10.14.

+ a) Packages containing fissile material in any form provided that:

- i) the smallest external dimension of the package is not less than 10 cm;
- ii) the criticality safety index of the package is calculated using the following formula:

$$CSI=50 \times 5 \times \left(\frac{\text{Mass of U-235 in package(g)}}{Z} \right) + \left(\frac{\text{Mass of other fissile nuclides* in package (g)}}{280} \right)$$

where the values of Z are taken from Table 6-6.

* Plutonium may be of any isotopic composition provided that the amount of Pu-241 is less than that of Pu-240 in the package

- iii) the CSI of any package does not exceed 10;

+ b) packages containing fissile material in any form provided that:

- i) the smallest external dimension of the package is not less than 30 cm;
- ii) the package, after being subjected to the tests specified in 7.14.1 to 7.14.6:
 - retains its fissile material contents;
 - preserves the minimum overall outside dimensions of the package to at least 30 cm;
 - prevents the entry of a 10 cm cube;
- iii) the criticality safety index of the package is calculated using the following formula:

$$CSI=50 \times 2 \times \left(\frac{\text{Mass of U-235 in package(g)}}{Z} \right) + \left(\frac{\text{Mass of other fissile nuclides* in package (g)}}{280} \right)$$

where the values of Z are taken from Table 6-6.

* Plutonium may be of any isotopic composition provided that the amount of Pu-241 is less than that of Pu-240 in the package

- (iv) the criticality safety index of any package does not exceed 10;

+ c) packages containing fissile material in any form provided that:

- i) the smallest external dimension of the package is not less than 10 cm;
- ii) the package, after being subjected to the tests specified in 7.14.1 to 7.14.6:
 - retains its fissile material contents;
 - preserves the minimum overall outside dimensions of the package to at least 10 cm;
 - prevents the entry of a 10 cm cube;
- iii) the criticality safety index of the package is calculated using the following formula:

$$CSI=50 \times 2 \times \left(\frac{\text{Mass of U-235 in package(g)}}{450} \right) + \left(\frac{\text{Mass of other fissile nuclides* in package (g)}}{280} \right)$$

* Plutonium may be of any isotopic composition provided that the amount of Pu-241 is less than that of Pu-240 in the package

- iv) the maximum mass of fissile nuclides in any package does not exceed 15 g;

+ d) the total mass of beryllium, hydrogenous material enriched in deuterium, graphite and other allotropic forms of carbon in an individual package must not be greater than the mass of fissile nuclides in the package except where their total concentration does not exceed 1 g in any 1 000 g of material. Beryllium incorporated in copper alloys up to 4 per cent in weight of the alloy does not need to be considered.

+ **Table 6-6. Values of Z for calculation of criticality safety index in accordance with 7.10.2**

<i>Enrichment**a</i>	<i>Z</i>
Uranium enriched up to 1.5%	2 200
Uranium enriched up to 5%	850
Uranium enriched up to 10%	660
Uranium enriched up to 20%	580
Uranium enriched up to 100%	450

* If a package contains uranium with varying enrichments of U-235, then the value corresponding to the highest enrichment must be used for Z.

+ 7.10.3 Packages containing not more than 1 000 g of plutonium are excepted from the application of 7.10.4 to 7.4.14 provided that:

- a) not more than 20 per cent of the plutonium by mass is fissile nuclides;
- b) the criticality safety index of the package is calculated using the following formula:

$$CSI = 50 \times 2 \times \left(\frac{\text{Mass of plutonium (g)}}{1\,000} \right)$$

- c) if uranium is present with the plutonium, the mass of uranium must be no more than 1 per cent of the mass of the plutonium.

≠ 7.10.4 Where the chemical or physical form, isotopic composition, mass or concentration, moderation ratio or density, or geometric configuration is not known, the assessments of 7.10.8 to 7.10.13 must be performed assuming that each parameter that is not known has the value which gives the maximum neutron multiplication consistent with the known conditions and parameters in these assessments.

≠ 7.10.5 For irradiated nuclear fuel the assessments of 7.10.8 to 7.10.13 must be based on an isotopic composition demonstrated to provide:

- a) the maximum neutron multiplication during the irradiation history; or
- b) a conservative estimate of the neutron multiplication for the package assessments. After irradiation but prior to shipment, a measurement must be performed to confirm the conservatism of the isotopic composition.

≠ 7.10.6 The package, after being subjected to the tests specified in 7.14, must:

- a) preserve the minimum overall outside dimensions of the package to at least 10 cm; and
- b) prevent the entry of a 10-cm cube.

≠ 7.10.7 The package must be designed for an ambient temperature range of -40°C to $+38^{\circ}\text{C}$ unless the competent authority specifies otherwise in the certificate of approval for the package design.

≠ 7.10.8 For a package in isolation, it must be assumed that water can leak into or out of all void spaces of the package, including those within the containment system. However, if the design incorporates special features to prevent such leakage of water into or out of certain void spaces, even as a result of error, absence of leakage may be assumed in respect of those void spaces. Special features must include either of the following:

- ≠ a) multiple high standard water barriers not less than two of which would remain watertight if the package were subject to the tests prescribed in 7.10.13 b), a high degree of quality control in the manufacture, maintenance and repair of packagings and tests to demonstrate the closure of each package before each shipment; or
- b) for packages containing uranium hexafluoride only, with maximum enrichment of 5 mass per cent uranium-235:
 - ≠ i) packages where, following the tests prescribed in 7.10.13 b), there is no physical contact between the valve and any other component of the packaging other than at its original point of attachment and where, in addition, following the test prescribed in 7.16.3, the valves remain leaktight; and
 - ii) a high degree of quality control in the manufacture, maintenance and repair of packagings coupled with tests to demonstrate closure of each package before each shipment.

- ≠ 7.10.9 It must be assumed that the confinement system is closely reflected by at least 20 cm of water or such greater reflection as may additionally be provided by the surrounding material of the packaging. However, when it can be demonstrated that the confinement system remains within the packaging following the tests prescribed in 7.10.13 b), close reflection of the package by at least 20 cm of water may be assumed in 7.10.10 c).
- ≠ 7.10.10 The package must be subcritical under the conditions of 7.10.8 and 7.10.9, with the package conditions that result in the maximum neutron multiplication consistent with:
- a) routine conditions of transport (incident free);
- ≠ b) the tests specified in 7.10.12 b);
- ≠ c) the tests specified in 7.10.13 b).
- ≠ 7.10.11:
- a) The package must be subcritical under conditions consistent with the Type C package tests specified in 7.19.1 assuming reflection by at least 20 cm of water but no water-in leakage.
- ≠ b) In the assessment of 7.10.10, allowance must not be made for special features of 7.10.8 unless, following the Type C package tests specified in 7.19.1 and, subsequently, the water-in leakage test of 7.18.3, leakage of water into or out of the void spaces is prevented.
- ≠ 7.10.12 A number "N" must be derived, such that five times "N" must be subcritical for the arrangement and package conditions that provide the maximum neutron multiplication consistent with the following:
- a) There must not be anything between the packages, and the package arrangement must be reflected on all sides by at least 20 cm of water; and
 - b) The state of the packages must be their assessed or demonstrated condition if they had been subjected to the tests specified in 7.14.
- ≠ 7.10.13 A number "N" must be derived, such that two times "N" must be subcritical for the arrangement and package conditions that provide the maximum neutron multiplication consistent with the following:
- a) hydrogenous moderation between packages, and the package arrangement reflected on all sides by at least 20 cm of water; and
 - b) the tests specified in 7.14 followed by whichever of the following is the more limiting:
 - i) the tests specified in 7.16.2 b) and, either 7.16.2 c) for packages having a mass not greater than 500 kg and an overall density not greater than 1 000 kg/m³ based on the external dimensions, or 7.16.2 a) for all other packages; followed by the test specified in 7.16.3 and completed by the tests specified in 7.18.1 to 7.18.3; or
 - ii) the test specified in 7.16.4; and
 - c) where any part of the fissile material escapes from the containment system following the tests specified in 7.10.13 b), it must be assumed that fissile material escapes from each package in the array and all of the fissile material must be arranged in the configuration and moderation that results in the maximum neutron multiplication with close reflection by at least 20 cm of water.
- ≠ 7.10.14 The criticality safety index (CSI) for packages containing fissile material must be obtained by dividing the number 50 by the smaller of the two values of N derived in 7.10.12 and 7.10.13 (i.e. CSI = 50/N). The value of the CSI may be zero, provided that an unlimited number of packages is subcritical (i.e. N is effectively equal to infinity in both cases).

7.11 TEST PROCEDURES AND DEMONSTRATION OF COMPLIANCE

7.11.1 Demonstration of compliance with the performance standards required in 2;7.2.3.1.3, 2;7.2.3.1.4, 2;7.2.3.3.1, 2;7.2.3.3.2, 2;7.2.3.4.1, 2;7.2.3.4.2 and 6;7.1 to 6;7.10 must be accomplished by any of the methods listed below or by a combination thereof:

- a) Performance of tests with specimens representing LSA-III material, or special form radioactive material, or low dispersible radioactive material or with prototypes or samples of the packaging, where the contents of the specimen or the packaging for the tests must simulate, as closely as practicable, the expected range of radioactive contents and the specimen or packaging to be tested must be prepared as presented for transport;
- b) Reference to previous satisfactory demonstrations of a sufficiently similar nature;

- c) Performance of tests with models of appropriate scale incorporating those features which are significant with respect to the item under investigation when engineering experience has shown results of such tests to be suitable for design purposes. When a scale model is used, the need for adjusting certain test parameters, such as penetrator diameter or compressive load, must be taken into account;
- d) Calculation, or reasoned argument, when the calculation procedures and parameters are generally agreed to be reliable or conservative.

7.11.2 After the specimen, prototype or sample has been subjected to the tests, appropriate methods of assessment must be used to assure that the requirements for the test procedures have been fulfilled in compliance with the performance and acceptance standards prescribed in 2;7.2.3.1.3, 2;7.2.3.1.4, 2;7.2.3.3.1, 2;7.2.3.3.2, 2;7.2.3.4.1, 2;7.2.3.4.2 and 6;7.1 to 6;7.10.

7.11.3 All specimens must be inspected before testing in order to identify and record faults or damage including the following:

- a) divergence from the design;
- b) defects in manufacture;
- c) corrosion or other deterioration; and
- d) distortion of features.

The containment system of the package must be clearly specified. The external features of the specimen must be clearly identified so that reference may be made simply and clearly to any part of such a specimen.

7.12 TESTING THE INTEGRITY OF THE CONTAINMENT SYSTEM AND SHIELDING AND EVALUATING CRITICALITY SAFETY

After each of the applicable tests specified in 7.14 to 7.20:

- a) faults and damages must be identified and recorded;
- b) it must be determined whether the integrity of the containment system and shielding has been retained to the extent required in 7.1 to 7.10 for the package under test; and
- ≠ c) it must be determined, for packages containing fissile material, whether the assumptions and conditions used in the assessments required by 7.10.1 to 7.10.14 for one or more packages are valid.

7.13 TARGET FOR DROP TESTS

The target for the drop tests specified in 2;7.2.3.3.5 a), 7.14.4, 7.15 a), 7.16.2 and 7.19.2 must be a flat, horizontal surface of such a character that any increase in its resistance to displacement or deformation upon impact by the specimen would not significantly increase the damage to the specimen.

7.14 TESTS FOR DEMONSTRATING ABILITY TO WITHSTAND NORMAL CONDITIONS OF TRANSPORT

7.14.1 The tests are: the water spray test, the free drop test, the stacking test and the penetration test. Specimens of the package must be subjected to the free drop test, the stacking test and the penetration test, preceded in each case by the water spray test. One specimen may be used for all the tests, provided that the requirements of 7.14.2 are fulfilled.

7.14.2 The time interval between the conclusion of the water spray test and the succeeding test must be such that the water has soaked in to the maximum extent, without appreciable drying of the exterior of the specimen. In the absence of any evidence to the contrary, this interval must be taken to be two hours if the water spray is applied from four directions simultaneously. No time interval must elapse, however, if the water spray is applied from each of the four directions consecutively.

7.14.3 Water spray test: the specimen must be subjected to a water spray test that simulates exposure to rainfall of approximately 5 cm per hour for at least one hour.

7.14.4 Free drop test: the specimen must drop onto the target so as to suffer maximum damage in respect of the safety features to be tested.

- a) The height of the drop measured from the lowest point of the specimen to the upper surface of the target must be not less than the distance specified in Table 6-6 for the applicable mass. The target must be as defined in 7.13;

- b) For rectangular fibreboard or wood packages not exceeding a mass of 50 kg, a separate specimen must be subjected to a free drop onto each corner from a height of 0.3 m;
- c) For cylindrical fibreboard packages not exceeding a mass of 100 kg, a separate specimen must be subjected to a free drop onto each of the quarters of each rim from a height of 0.3 m.

#

Table 6-7. Free drop distance for testing packages to normal conditions of transport

<i>Package mass (kg)</i>	<i>Free drop distance (m)</i>
Package mass < 5 000	1.2
5 000 ≤ Package mass < 10 000	0.9
10 000 ≤ Package mass < 15 000	0.6
15 000 ≤ Package mass	0.3

7.14.5 Stacking test: unless the shape of the packaging effectively prevents stacking, the specimen must be subjected, for a period of 24 hours, to a compressive load equal to the greater of the following:

#

- a) the equivalent of five times the maximum weight of the package; and
- b) the equivalent of 13 kPa multiplied by the vertically projected area of the package.

The load must be applied uniformly to two opposite sides of the specimen, one of which must be the base on which the package would typically rest.

7.14.6 Penetration test: the specimen must be placed on a rigid, flat, horizontal surface which will not move significantly while the test is being carried out.

- a) A bar of 3.2 cm in diameter with a hemispherical end and a mass of 6 kg must be dropped and directed to fall, with its longitudinal axis vertical, onto the centre of the weakest part of the specimen so that, if it penetrates sufficiently far, it will hit the containment system. The bar must not be significantly deformed by the test performance;
- b) The height of the drop of the bar measured from its lower end to the intended point of impact on the upper surface of the specimen must be 1 m.

7.15 ADDITIONAL TESTS FOR TYPE A PACKAGES DESIGNED FOR LIQUIDS AND GASES

A specimen or separate specimens must be subjected to each of the following tests, unless it can be demonstrated that one test is more severe for the specimen in question than the other, in which case one specimen must be subjected to the more severe test.

- a) Free drop test: the specimen must drop onto the target so as to suffer the maximum damage in respect of containment. The height of the drop measured from the lowest part of the specimen to the upper surface of the target must be 9 m. The target must be as defined in 7.13;
- b) Penetration test: the specimen must be subjected to the test specified in 7.14.6 except that the height of the drop must be increased to 1.7 m from the 1 m specified in 7.14.6 b).

7.16 TESTS FOR DEMONSTRATING THE ABILITY TO WITHSTAND ACCIDENT CONDITIONS IN TRANSPORT

7.16.1 The specimen must be subjected to the cumulative effects of the tests specified in 7.16.2 and 7.16.3, in that order. Following these tests, either this specimen or a separate specimen must be subjected to the effect(s) of the water immersion test(s) as specified in 7.16.4 and, if applicable, 7.17.

#

7.16.2 Mechanical test: the mechanical test consists of three different drop tests. Each specimen must be subjected to the applicable drops as specified in 7.7.8 or 7.10.13. The order in which the specimen is subjected to the drops must be such that, on completion of the mechanical test, the specimen must have suffered such damage as will lead to the maximum damage in the thermal test which follows:

- a) For drop I, the specimen must drop onto the target so as to suffer the maximum damage, and the height of the drop measured from the lowest point of the specimen to the upper surface of the target must be 9 m. The target must be as defined in 7.13;
- ≠ b) For drop II, the specimen must drop onto a bar rigidly mounted perpendicularly on the target so as to suffer the maximum damage. The height of the drop measured from the intended point of impact of the specimen to the upper surface of the bar must be 1 m. The bar must be of solid mild steel of circular section, $(15.0 \pm 0.5 \text{ cm})$ in diameter and 20 cm long unless a longer bar would cause greater damage, in which case a bar of sufficient length to cause maximum damage must be used. The upper end of the bar must be flat and horizontal with its edge rounded off to a radius of not more than 6 mm. The target on which the bar is mounted must be as described in 7.13;
- ≠ c) For drop III, the specimen must be subjected to a dynamic crush test by positioning the specimen on the target so as to suffer maximum damage by the drop of a 500 kg mass from 9 m onto the specimen. The mass must consist of a solid mild steel plate 1 m by 1 m and must fall in a horizontal attitude. The lower face of the steel plate must have its edges and corners rounded off to a radius of not more than 6 mm. The height of the drop must be measured from the underside of the plate to the highest point of the specimen. The target on which the specimen rests must be as defined in 7.13.

7.16.3 Thermal test: the specimen must be in thermal equilibrium under conditions of an ambient temperature of 38°C, subject to the solar insolation conditions specified in Table 6-5 and subject to the design maximum rate of internal heat generation within the package from the radioactive contents. Alternatively, any of these parameters are allowed to have different values prior to and during the test, provided due account is taken of them in the subsequent assessment of package response. The thermal test must then consist of:

- a) exposure of a specimen for a period of 30 minutes to a thermal environment which provides a heat flux at least equivalent to that of a hydrocarbon fuel/air fire in sufficiently quiescent ambient conditions to give a minimum average flame emissivity coefficient of 0.9 and an average temperature of at least 800°C, fully engulfing the specimen, with a surface absorptivity coefficient of 0.8 or that value which the package may be demonstrated to possess if exposed to the fire specified, followed by;
- b) exposure of the specimen to an ambient temperature of 38°C, subject to the solar insolation conditions specified in Table 6-5 and subject to the design maximum rate of internal heat generation within the package by the radioactive contents for a sufficient period to ensure that temperatures in the specimen are everywhere decreasing and/or are approaching initial steady-state conditions. Alternatively, any of these parameters are allowed to have different values following cessation of heating, provided due account is taken of them in the subsequent assessment of package response.

During and following the test, the specimen must not be artificially cooled and any combustion of materials of the specimen must be permitted to proceed naturally.

7.16.4 Water immersion test: the specimen must be immersed under a head of water of at least 15 m for a period of not less than eight hours in the attitude which will lead to maximum damage. For demonstration purposes, an external gauge pressure of at least 150 kPa must be considered to meet these conditions.

7.17 ENHANCED WATER IMMERSION TEST FOR TYPE B(U) AND TYPE B(M) PACKAGES CONTAINING MORE THAN 10^5 A_2 , AND TYPE C PACKAGES

Enhanced water immersion test: the specimen must be immersed under a head of water of at least 200 m for a period of not less than one hour. For demonstration purposes, an external gauge pressure of at least 2 MPa must be considered to meet these conditions.

7.18 WATER LEAKAGE TEST FOR PACKAGES CONTAINING FISSILE MATERIAL

- ≠ 7.18.1 Packages for which water-in leakage or out-leakage to the extent which results in the greatest reactivity has been assumed, for purposes of assessment under 7.10.8 to 7.10.13, must be excepted from the test.
- ≠ 7.18.2 Before the specimen is subjected to the water leakage test specified below, it must be subjected to the tests in 7.16.2 b) and either 7.16.2 a) or c) as required by 7.10.13 and the test specified in 7.16.3.

7.18.3 The specimen must be immersed under a head of water of at least 0.9 m for a period of not less than eight hours and in the attitude for which maximum leakage is expected.

7.19 TESTS FOR TYPE C PACKAGES

7.19.1 Specimens must be subjected to the effects of each of the following test sequences in the orders specified:

- a) the tests specified in 7.16.2 a), 7.16.2 c), 7.19.2 and 7.19.3; and
- b) the test specified in 7.19.4.

Separate specimens are allowed to be used for each of the sequences in a) and b).

≠ 7.19.2 Puncture/tearing test: the specimen must be subjected to the damaging effects of a vertical solid probe made of mild steel. The orientation of the package specimen and the impact point on the package surface must be such as to cause maximum damage at the conclusion of the test sequence specified in 7.19.1 a).

- a) The specimen, representing a package having a mass less than 250 kg, must be placed on a target and subjected to a probe having a mass of 250 kg and falling from a height of 3 m above the intended impact point. For this test, the probe must be a 20 cm in diameter cylindrical bar with the striking end forming a frustum of a right circular cone with the following dimensions: 30 cm in height and 2.5 cm in diameter at the top with its edge rounded off to a radius of not more than 6 mm. The target on which the specimen is placed must be as specified in 7.13;
- b) For packages having a mass of 250 kg or more, the base of the probe must be placed on a target and the specimen dropped onto the probe. The height of the drop, measured from the point of impact with the specimen to the upper surface of the probe must be 3 m. For this test, the probe must have the same properties and dimensions as specified in a) above, except that the length and mass of the probe must be such as to incur maximum damage to the specimen. The target on which the base of the probe is placed must be as specified in 7.13.

7.19.3 Enhanced thermal test: the conditions for this test must be as specified in 7.16.3, except that the exposure to the thermal environment must be for a period of 60 minutes.

7.19.4 Impact test: the specimen must be subject to an impact on a target at a velocity of not less than 90 m/s, at such an orientation as to suffer maximum damage. The target must be as defined in 7.13, except that the target surface may be at any orientation as long as the surface is normal to the specimen path.

7.20 TESTS FOR PACKAGINGS DESIGNED TO CONTAIN URANIUM HEXAFLUORIDE

Specimens that comprise or simulate packagings designed to contain 0.1 kg or more of uranium hexafluoride must be tested hydraulically at an internal pressure of at least 1.38 MPa but, when the test pressure is less than 2.76 MPa, the design must require multilateral approval. For re-testing packagings, any other equivalent non-destructive testing may be applied subject to multilateral approval.

7.21 APPROVALS OF PACKAGE DESIGNS AND MATERIALS

7.21.1 The approval of designs for packages containing 0.1 kg or more of uranium hexafluoride requires that:

- a) each design that meets the requirements of 7.5.4 requires multilateral approval;
- b) each design that meets the requirements of 7.5.1 to 7.5.3 must require unilateral approval by the competent authority of the State of Origin of the design, unless multilateral approval is otherwise required by these Instructions.

7.21.2 Each Type B(U) and Type C package design requires unilateral approval, except that:

- a) a package design for fissile material, which is also subject to 5;1.2.2.1 and 7.21.4 must require multilateral approval; and
- b) a Type B(U) package design for low dispersible radioactive material must require multilateral approval.

7.21.3 Each Type B(M) package design, including those for fissile material which are also subject to 5;1.2.2.1 and 7.21.4 and those for low dispersible radioactive material, must require multilateral approval.

≠ 7.21.4 Each package design for fissile material which is not excepted by any of the paragraphs 2;7.2.3.5.1 a) to f), 7.10.2 and 7.10.3 must require multilateral approval.

7.21.5 The design for special form radioactive material must require unilateral approval. The design for low dispersible radioactive material must require multilateral approval (see also 6.4.23.8 of the UN Recommendations).

+ 7.21.6 The design for a fissile material excepted from fissile classification in accordance with 2;7.2.3.5.1 f) must require multilateral approval.

- + 7.21.7 Alternative activity limits for an exempt consignment of instruments or articles in accordance with 2;7.2.2.2 b) must require multilateral approval.

+ **7.22 APPLICATIONS AND APPROVALS FOR RADIOACTIVE MATERIAL TRANSPORT**

See 6.4.23 of the UN Model Regulations.

≠ **7.23 REGISTRATION OF SERIAL NUMBERS AND VALIDATION**

- ≠ 7.23.1 The competent authority must be informed of the serial number of each packaging manufactured to a design approved by them. The competent authority must maintain a register of such numbers.

- ≠ 7.23.2 Multilateral approval may be by validation of the original certificate issued by the competent authority of the State of Origin of the design or shipment.

≠ **7.24 TRANSITIONAL MEASURES FOR CLASS 7**

≠ **7.24.1 Packages not requiring competent authority approval of design under the 1985 and 1985 (As Amended 1990) editions of IAEA Safety Series No. 6**

- ≠ 7.24.1.1 Packages not requiring competent authority approval of design (excepted packages, Type IP-1, Type IP-2, Type IP-3 and Type A packages) must meet these Instructions in full, except that packages that meet the requirements of the 1985 or 1985 (As Amended 1990) Editions of IAEA Regulations for the Safe Transport of Radioactive Material (IAEA Safety Series No.6):

- + a) may continue in transport provided that they were prepared for transport prior to 31 December 2003, and subject to the requirements of 7.24.4, if applicable;
- + b) may continue to be used provided that:
- i) they were not designed to contain uranium hexafluoride;
 - ii) the applicable requirements of 1;6.3 of these Instructions are applied;
 - iii) the activity limits and classification in Part 2;7 of these Instructions are applied;
 - iv) the requirements and controls for transport in Parts 1, 3, 4, 5 and 7 of these Instructions are applied;
 - v) the packaging was not manufactured or modified after 31 December 2003.

- ≠ 7.24.1.2 Any packaging modified, unless to improve safety, or manufactured after 31 December 2003, must meet the requirements of these Instructions in full. Packages prepared for transport not later than 31 December 2003 under the 1985 or 1985 (As Amended 1990) editions of IAEA Safety Series No. 6 may continue in transport. Packages prepared for transport after this date must meet the requirements of these Instructions in full.

≠ **7.24.2 Packages approved under the 1973, 1973 (As Amended), 1985 and 1985 (As Amended 1990) editions of IAEA Safety Series No. 6**

- ≠ 7.24.2.1 Packages requiring competent authority approval of the design must meet these Instructions in full unless the following conditions are met:

- + a) the packagings were manufactured to a package design approved by the competent authority under the provisions of the 1973 or 1973 (As Amended) or the 1985 or 1985 (As Amended 1990) Editions of IAEA Safety Series No.6);
- + b) the package design is subject to multilateral approval;
- + c) the applicable requirements of 1;6.3 of these Instructions are applied;
- + d) the activity limits and classification in Part 2;7 of these Instructions are applied;
- + e) the requirements and controls for transport in in Parts 1, 3, 4, 5 and 7 of these Instructions are applied;

- + f) for a package containing fissile material and transported by air, the requirement of 7.10.11 is met;
- + g) for packages that meet the requirements of the 1973 or 1973 (As Amended) Editions of IAEA Safety Series No. 6:
 - i) the packages retain sufficient shielding to ensure that the radiation level at 1 m from the surface of the package would not exceed 10 mSv/h in the accident conditions of transport defined in the 1973 Revised or 1973 Revised (As Amended) Editions of IAEA Safety Series No. 6 with the maximum radioactive contents which the package is authorized to contain;
 - ii) the packages do not utilize continuous venting;
 - iii) a serial number in accordance with the provision of 5;2.4.5.1 c) is assigned to and marked on the outside of each packaging.
- ≠ 7.24.2.2 No new manufacture of packagings to a package design meeting the provisions of the 1973, 1973 (As Amended), 1985, and 1985 (As Amended 1990) Editions of IAEA Safety Series No. 6 must be permitted to commence.

≠ **7.24.3 Special form radioactive material
approved under the 1973, 1973 (As Amended),
1985 and 1985 (As Amended 1990) editions
of IAEA Safety Series No. 6**

- ≠ Special form radioactive material manufactured to a design which had received unilateral approval by the competent authority under the 1973, 1973 (As Amended), 1985 or 1985 (As Amended 1990) editions of IAEA Safety Series No. 6 may continue to be used when in compliance with the mandatory management system in accordance with the applicable requirements of 1;6.3. No new manufacture of such special form radioactive material must be permitted to commence.

Part 7
OPERATOR'S RESPONSIBILITIES

INTRODUCTORY NOTE

This Part details the responsibilities of operators with regard to the acceptance, handling and loading of dangerous goods. However, nothing contained herein should be interpreted as requiring an operator to transport a particular article or substance or as preventing an operator from imposing special requirements on the transport of a particular article or substance. Also, nothing in this Part is intended to preclude a ground handling agent from carrying out some or all of the functions of an operator. However, such ground handling agents are subject to the operator's responsibilities of Part 7.

Chapter 1

ACCEPTANCE PROCEDURES

Parts of this Chapter are affected by State Variations AE 6, AU 5, CA 1, CA 4, CA 9, CH 3, CN 1, DK 2, FR 3, HK 1, HR 4, HR 5, IN 1, IN 2, IN 3, IR 1, IR 2, IR 4, IT 1, IT 5, MO 1, MY 2, NL 3, PL 1, RU 2, SG 1, SG 2, UA 1, US 10, US 13; see Table A-1

1.1 CARGO ACCEPTANCE PROCEDURES

1.1.1 Operators' acceptance staff must be adequately trained to assist them in identifying and detecting dangerous goods presented as general cargo.

1.1.2 Cargo acceptance staff should seek confirmation from shippers about the contents of any item of cargo where there are suspicions that it may contain dangerous goods, with the aim of preventing undeclared dangerous goods from being loaded on an aircraft as general cargo. Many innocuous-looking items may contain dangerous goods, and a list of general descriptions which, experience has shown, are often applied to such items is shown in Chapter 6.

- + *Note 1.— Diamond-shaped GHS pictograms on packages may indicate the presence of dangerous goods. While some pictograms identify substances that only pose a hazard for supply and use, other GHS pictograms contain symbols that are largely equivalent to the symbols contained in the hazard labels used in transport, and which may therefore be classified as dangerous goods. For more information, see [www. http://www.unece.org/trans/danger/publi/ghs/ghs_welcome_e.html](http://www.unece.org/trans/danger/publi/ghs/ghs_welcome_e.html).*
- ≠ *Note 2.— Often general names are used in the description of the content of a cargo shipment. To assist in the detection of undeclared dangerous goods, acceptance staff should check shipping documents with the general description stated on the air waybill and, if necessary, request documentary evidence from shippers that the shipment does not contain dangerous goods.*

1.2 ACCEPTANCE OF DANGEROUS GOODS BY OPERATORS

1.2.1 An operator must not accept for transport aboard an aircraft a package or overpack containing dangerous goods or a freight container containing radioactive material or a unit load device or other type of pallet containing the dangerous goods as described in 1.4.1 b) and c) unless:

- a) it is accompanied by two copies of the dangerous goods transport document; or
- b) the information applicable to the consignment is provided in electronic form; or
- c) it is accompanied, where permitted, by alternative documentation.

1.2.2 Where a dangerous goods transport document is provided in accordance with 1.2.1 a), one copy must accompany the consignment to final destination and one copy must be retained by the operator at a location on the ground where it will be possible to obtain access to it within a reasonable period; the document must be retained at this point until the goods have arrived at final destination, after which time it may be stored elsewhere.

1.2.3 When the information applicable to the consignment is provided in electronic form, the information must be available to the operator at all times during transport to final destination. The data must be able to be produced as a paper document without delay. When a paper document is produced, the data must be presented as required by 5;4.

1.3 THE ACCEPTANCE CHECK

- ≠ 1.3.1 Before a consignment consisting of a package or overpack containing dangerous goods, a freight container containing radioactive material or a unit load device or other type of pallet containing dangerous goods as described in 1.4 is first accepted for carriage by air, the operator must, by use of a checklist, verify the following:
 - a) the documentation or, when provided, the electronic data, complies with the detailed requirements specified in 5;4;
 - b) the quantity of dangerous goods stated on the dangerous goods transport document is within the limits per package on a passenger or cargo aircraft as appropriate;

- c) the marking of the package, overpack or freight container accords with the details stated on the accompanying dangerous goods transport document and are clearly visible;
- d) where required, the letter in the packaging specification marking designating the packing group for which the design type has been successfully tested is appropriate for the dangerous goods contained within. This does not apply to overpacks where the specification marking is not visible;
- e) proper shipping names, UN numbers, labels, and special handling instructions appearing on the interior package(s) are clearly visible or reproduced on the outside of an overpack;
- f) the labelling of the package, overpack or freight container is as required by 5.3;
- g) the outer packaging of a combination packaging or the single packaging is permitted by the applicable packing instruction, and, when visible, is of the type stated on the accompanying dangerous goods transport document;
- h) the package or overpack does not contain different dangerous goods which require segregation from each other according to Table 7-1; and
- i) the package, overpack, freight container or unit load device is not leaking and there is no indication that its integrity has been compromised.

> *Note 1.— Minor discrepancies, such as the omission of dots and commas in the proper shipping name appearing on the transport document or on package markings, or minor variations in hazard labels which do not affect the obvious meaning of the label, are not considered as errors if they do not compromise safety and should not be considered as reason for rejecting a consignment.*

Note 2.— Where packages are contained in an overpack or freight container, as permitted by 1.4, the checklist should establish the correct marking and labelling of such an overpack or other type of pallet or freight container and not the individual packages contained in them. Where packages are contained in a unit load device, as permitted by 1.4.1, the checklist should not require the checking of packages individually for the correct marking and labelling.

Note 3.— An acceptance check is not required for dangerous goods in excepted quantities and radioactive material in excepted packages.

+ *Note 4.— Although the acceptance check required in 1.3.1 is only required to be conducted when a consignment of dangerous goods is first accepted for carriage by air, the operator of any subsequent aircraft used as part of the same journey should verify that packages, overpacks, freight containers or unit load devices continue to meet the requirements of these Instructions in respect of marking, labelling and inspection for damage.*

1.4 ACCEPTANCE OF FREIGHT CONTAINERS AND UNIT LOAD DEVICES

1.4.1 An operator must not accept from a shipper a freight container or a unit load device containing dangerous goods other than:

- a) a freight container for radioactive material (see 6.7.1);
- b) a unit load device or other type of pallet containing consumer commodities prepared according to Packing Instruction Y963;
- c) a unit load device or other type of pallet containing dry ice used as a refrigerant for other than dangerous goods prepared according to Packing Instruction 954; or
- d) a unit load device or other type of pallet containing magnetized material.

≠ 1.4.2 When an operator accepts a unit load device or other type of pallet containing consumer commodities or dry ice as permitted by 1.4.1, the operator must attach an identification tag as required by 2.8.1 to the unit load device.

1.5 SPECIAL RESPONSIBILITIES IN ACCEPTING INFECTIOUS SUBSTANCES

1.5.1 Routing

Whatever the mode used, transport must be made by the quickest possible routing. If trans-shipment is necessary, precautions must be taken to ensure special care, expeditious handling and monitoring of the substances in transit.

6. UNDELIVERABLE CONSIGNMENTS OF RADIOACTIVE MATERIAL

Where a consignment is undeliverable, the consignment must be placed in a safe location and the appropriate competent authority must be informed as soon as possible and a request made for instructions on further action.

Chapter 2

STORAGE AND LOADING

Parts of this Chapter are affected by State Variations CA 1, CA 4, IR 2, IR 4, JP 9, JP 10, JP 11, JP 12, US 15; see Table A-1

2.1 LOADING RESTRICTIONS ON THE FLIGHT DECK AND FOR PASSENGER AIRCRAFT

2.1.1 Dangerous goods must not be carried in an aircraft cabin occupied by passengers or on the flight deck of an aircraft, except as permitted by 1;2.2.1 and 8;1 and for radioactive material, excepted packages under 2;7.2.4.1.1. Dangerous goods may be carried in a main deck cargo compartment of a passenger aircraft provided that compartment meets all the certification requirements for a Class B or a Class C aircraft cargo compartment. Dangerous goods bearing the "Cargo aircraft only" label must not be carried on a passenger aircraft.

2.1.2 Under the conditions specified in S-7;2.2 of the Supplement, the State of Origin and the State of the Operator may approve the transport of dangerous goods in main deck cargo compartments of passenger aircraft that do not meet the requirements in 2.1.1.

Note.— Cargo compartment classification is described in the ICAO document Emergency Response Guidance for Aircraft Incidents Involving Dangerous Goods (Doc 9481).

2.1.3 For additional requirements concerning the loading of dangerous goods for carriage by helicopters, see Part 7;7.

2.2 INCOMPATIBLE DANGEROUS GOODS

2.2.1 Segregation

Packages containing dangerous goods which might react dangerously one with another must not be stowed on an aircraft next to each other or in a position that would allow interaction between them in the event of leakage. As a minimum, the segregation scheme shown in Table 7-1 must be followed in order to maintain acceptable segregation between packages containing dangerous goods having different hazards. The scheme applies irrespective of whether the hazard is the primary or subsidiary risk.

2.2.2 Separation of explosive substances and articles

2.2.2.1 Only explosives in Division 1.4, Compatibility Group S, are permitted to be transported on passenger aircraft. Only the following explosives may be transported on a cargo aircraft:

Division 1.3: Compatibility Groups C, G

Division 1.4: Compatibility Groups B, C, D, E, G, S.

2.2.2.2 The extent to which explosives may be stowed together in an aircraft is determined by their "compatibility". Explosives are considered to be compatible if they can be stowed together without significantly increasing either the probability of an accident or, for a given quantity, the magnitude of the effects of such an accident.

2.2.2.3 Explosives in Compatibility Group S may be stowed with explosives in all compatibility groups.

2.2.2.4 Except as provided for in 2.2.2.5, explosives of different compatibility groups may be stowed together whether or not they belong to the same division.

2.2.2.5 For explosives of different division numbers and compatibility groups, the segregation scheme shown in Table 7-2 must be followed in order to maintain acceptable distances between such packages.

Table 7-1. Segregation between packages

Hazard label	Class or division							
	1	2	3	4.2	4.3	5.1	5.2	8
1	Note 1	Note 2	Note 2	Note 2	Note 2	Note 2	Note 2	Note 2
2	Note 2	—	—	—	—	—	—	—
3	Note 2	—	—	—	—	x	—	—
4.2	Note 2	—	—	—	—	x	—	—
4.3	Note 2	—	—	—	—	—	—	x
5.1	Note 2	—	x	x	—	—	—	—
5.2	Note 2	—	—	—	—	—	—	—
8	Note 2	—	—	—	x	—	—	—

An “x” at the intersection of a row and column indicates that packages containing these classes of dangerous goods may not be stowed next to or in contact with each other, or in a position which would allow interaction in the event of leakage of the contents. Thus, a package containing Class 3 dangerous goods may not be stowed next to or in contact with a package containing Division 5.1 dangerous goods.

Note 1.— See 2.2.2.2 through 2.2.2.5.

Note 2.— This class or division must not be stowed together with explosives other than those in Division 1.4, Compatibility Group S.

Note 3. — Packages containing dangerous goods with multiple hazards in the class or divisions which require segregation in accordance with Table 7-1 need not be segregated from other packages bearing the same UN number.

Table 7-2. Separation of explosive substances and articles

Division and compatibility group	1.3C	1.3G	1.4B	1.4C	1.4D	1.4E	1.4G	1.4S
1.3C			x					
1.3G			x					
1.4B	x	x		x	x	x	x	
1.4C			x					
1.4D			x					
1.4E			x					
1.4G			x					
1.4S								

An “x” at the intersection of a row and column indicates that explosives of these divisions and compatibility groups must be loaded into separate unit load devices and, when stowed aboard the aircraft, the unit load devices must be separated by other cargo with a minimum separation distance of 2 m. When not loaded in a unit load device, these explosives must be loaded into different, non-adjacent loading positions and separated by other cargo with a minimum separation distance of 2 m.

2.3 HANDLING AND LOADING OF PACKAGES CONTAINING LIQUID DANGEROUS GOODS

During the course of air transport, a package of dangerous goods bearing the package orientation label prescribed in 5;3 must be loaded and stowed aboard an aircraft and handled at all times in accordance with such a label. Single packagings with end closures containing liquid dangerous goods must be loaded and stowed aboard an aircraft with those closures upwards, notwithstanding that such single packages may also have side closures.

2.4 LOADING AND SECURING OF DANGEROUS GOODS

2.4.1 Loading of cargo aircraft

2.4.1.1 Packages or overpacks of dangerous goods bearing the “Cargo aircraft only” label must be loaded for carriage by a cargo aircraft in accordance with one of the following provisions:

- a) in a Class C aircraft cargo compartment; or
- b) in a unit load device equipped with a fire detection/suppression system equivalent to that required by the certification requirements of a Class C aircraft cargo compartment as determined by the appropriate national authority (a ULD that is determined by the appropriate national authority to meet the Class C aircraft cargo compartment standards must include “Class C compartment” on the ULD tag); or
- c) in such a manner that in the event of an emergency involving such packages or overpacks, a crew member or other authorized person can access those packages or overpacks, and can handle and, where size and mass permit, separate such packages or overpacks from other cargo; or
- d) external carriage by a helicopter; or
- e) with the approval of the State of the Operator, for helicopter operations, in the cabin (see Part S-7;2.4 of the Supplement).

Note.— Cargo compartment classification is described in the ICAO document Emergency Response Guidance for Aircraft Incidents Involving Dangerous Goods (Doc 9481).

2.4.1.2 The requirements of 2.4.1.1 do not apply to:

- a) flammable liquids (Class 3), Packing Group III, other than those with a subsidiary risk of Class 8;
- b) toxic substances (Division 6.1) with no subsidiary risk other than Class 3;
- c) infectious substances (Division 6.2);
- d) radioactive material (Class 7);
- e) miscellaneous dangerous goods (Class 9).

Note — When transporting goods in a non-pressurized cargo hold, there will be a large pressure differential up to 75 kPa at cruise altitudes. Packages that are filled at a normal atmospheric pressure may not be capable of withstanding this pressure differential. Confirmation of the suitability of the packagings from the shipper should be obtained.

2.4.2 Securing of dangerous goods

The operator must secure dangerous goods in the aircraft in a manner that will prevent any movement. For packages or overpacks containing radioactive material, the securing must be adequate to ensure that the separation requirements in 2.9 are met at all times.

2.4.3 General loading requirements

When dangerous goods subject to the provisions herein are loaded in an aircraft, the operator must protect the packages of dangerous goods from being damaged, including by the movement of baggage, mail, stores or other cargo. Particular attention must be paid to the handling of packages during their preparation for transport, the type of aircraft on which they are to be carried and the method required to load that aircraft, so that accidental damage is not caused through dragging or mishandling of the packages.

2.5 DAMAGED PACKAGES OF DANGEROUS GOODS

Where any package of dangerous goods loaded on an aircraft appears to be damaged or leaking, the operator must remove such package from the aircraft, or arrange for its removal by an appropriate authority or organization, and thereafter arrange for its safe disposal. In the case of a package which appears to be leaking, the operator must ensure the remainder of the consignment is in a proper condition for transport by air and that no other package, baggage or cargo has been contaminated. See 3.1 and 3.2 of this Part concerning action to be taken in the event of damage to packages containing infectious substances in Class 6 and radioactive materials in Class 7.

2.6 VISIBILITY OF MARKINGS AND LABELS

During the course of air transport, including storage, markings and labels required by these Instructions must not be covered or obscured by any part of or attachment to the packaging or any other label or marking.

2.7 REPLACEMENT OF LABELS

When an operator discovers that labels for packages of dangerous goods have become lost, detached or illegible the operator must replace them with appropriate labels in accordance with the information provided on the dangerous goods transport document.

2.8 IDENTIFICATION OF UNIT LOAD DEVICES CONTAINING DANGEROUS GOODS

≠ 2.8.1 Each unit load device containing dangerous goods which require a class hazard label must display an identification tag on its exterior indicating that dangerous goods are contained within the unit load device, unless those hazard class labels are themselves visible.

≠ 2.8.2 The identification tag must:

- ≠ a) have a border of prominent red hatchings on both sides and be visible at all times;
- ≠ b) have minimum dimensions of 148 mm × 210 mm; and
- ≠ c) be legibly marked with the primary and subsidiary hazard class(es) or division(s) numbers of such dangerous goods.

+ 2.8.3 When placed inside a protective tag holder, the information on the identification tag must be legible and visible.

≠ 2.8.4 If the unit load device contains packages bearing the "Cargo aircraft only" label, either that label must be visible or the identification tag must indicate that the unit load device can be loaded only on a cargo aircraft.

≠ 2.8.5 The identification tag must be removed from the unit load device immediately after the dangerous goods have been unloaded.

>

≠ 2.9 SPECIAL PROVISIONS APPLICABLE TO THE CARRIAGE OF RADIOACTIVE MATERIAL

≠ 2.9.1 Limitation of exposure of persons to radiation

≠ 2.9.1.1 The radiation exposure of transport and storage personnel must be so controlled that none of them are likely to receive a radiation dose in excess of that permitted for members of the public. In special cases, arrangements may be made with the competent authority for radiological control to have such personnel classified as radiation workers and to comply with the necessary provisions.

≠ 2.9.1.2 All relevant transport and storage personnel must receive such instructions as are necessary concerning the hazards involved and the precautions to be observed.

≠ 2.9.1.3 The practice should be followed of keeping exposure to radiation as low as reasonably achievable. The separation distances shown in Tables 7-3 and 7-4 are minimum values, and greater distances should be used where feasible. As far as possible, packages of radioactive materials stowed in underfloor cargo compartments of passenger aircraft should be placed on the compartment floor.

Note.— The separation distances from packages of radioactive material to passengers specified in Table 7-3 are based on a 0.02 mSv/h reference dose rate at a seat height of 0.4 m.

≠ **2.9.2 Activity limits**

The total activity in all aircraft, for carriage of LSA material or SCO in Type IP-1, Type IP-2, Type IP-3, must not exceed the limits shown in Table 7-5.

≠ **2.9.3 Stowage during transport and storage in transit**

≠ 2.9.3.1 Consignments must be securely stowed.

≠ 2.9.3.2 Provided that its average surface heat flux does not exceed 15 W/m^2 and that the immediately surrounding cargo is not in sacks or bags, a package or overpack may be carried or stored among packaged general cargo without any special stowage provisions except as may be specifically required by the competent authority in an applicable certificate of approval.

≠ 2.9.3.3 Loading of freight containers and accumulation of packages, overpacks and freight containers must be controlled as follows:

- a) Except under the condition of exclusive use, the total number of packages, overpacks and freight containers aboard a single aircraft must be so limited that the total sum of the transport indexes aboard the aircraft does not exceed the values shown in Table 7-6. For consignments of LSA-I material, there is no limit on the sum of the transport indexes;
- b) Where a consignment is transported under exclusive use, there is no limit on the sum of the transport indexes aboard a single aircraft, but the requirement on minimum segregation distances established in 2.9.6 applies;
- c) The radiation level under routine conditions of transport must not exceed 2 mSv/h at any point on, and 0.1 mSv/h at 2 m from, the external surface of the aircraft;
- d) The total sum of the criticality safety indexes in a freight container and aboard an aircraft must not exceed the values shown in Table 7-7.

≠ 2.9.3.4 Any package or overpack having either a transport index greater than 10, or any consignment having a criticality safety index greater than 50, must be transported only under exclusive use.

≠ **2.9.4 Additional requirements relating to transport and storage during transit of fissile material**

≠ 2.9.4.1 Any group of packages, overpacks and freight containers containing fissile material stored in transit in any one storage area must be so limited that the total sum of the criticality safety indexes in the group does not exceed 50. Each group must be stored so as to maintain a spacing of at least 6 m from other such groups.

Table 7-3. Minimum distance from surface of packages, overpacks and freight containers of radioactive material to the nearest inside surface of passenger cabin or flight deck partitions or floors, irrespective of carriage duration

<i>Total sum of transport indexes</i>	<i>Minimum distance (metres)</i>
0.1 – 1.0	0.30
1.1 – 2.0	0.50
2.1 – 3.0	0.70
3.1 – 4.0	0.85
4.1 – 5.0	1.00
5.1 – 6.0	1.15
6.1 – 7.0	1.30
7.1 – 8.0	1.45
8.1 – 9.0	1.55
9.1 – 10.0	1.65
10.1 – 11.0	1.75
11.1 – 12.0	1.85
12.1 – 13.0	1.95
13.1 – 14.0	2.05
14.1 – 15.0	2.15
15.1 – 16.0	2.25
16.1 – 17.0	2.35
17.1 – 18.0	2.45
18.1 – 20.0	2.60
20.1 – 25.0	2.90
25.1 – 30.0	3.20
30.1 – 35.0	3.50

<i>Total sum of transport indexes</i>	<i>Minimum distance (metres)</i>
35.1 – 40.0	3.75
40.1 – 45.0	4.00
45.1 – 50.0	4.25

If more than one package, overpack or freight container is placed in the aircraft, the minimum separation distance for each individual package, overpack or freight container must be determined in accordance with the above table, on the basis of the sum of the transport index numbers of the individual packages, overpacks or freight containers. Alternatively, if the packages, overpacks or freight containers are separated into groups, the minimum distance from the nearest inside surface of the passenger cabin or flight deck partitions or floors to each group is the distance applicable to the sum of the transport indexes within the individual groups, provided that each group is separated from each other group by at least three times the distance applicable to the one that has the larger sum of transport indexes.

Note.— For total sum of transport indexes over 50 to be carried by cargo aircraft only, see Table 7-4.

Table 7-4. Minimum distance from surface of packages, overpacks and freight containers of radioactive material, carried by cargo aircraft only, to the nearest inside surface of the flight deck partitions or floor, or other areas occupied by personnel, irrespective of carriage duration

<i>Total sum of transport indexes</i>	<i>Minimum distance (metres)</i>	<i>Total sum of transport indexes</i>	<i>Minimum distance (metres)</i>
50.1 – 60.0	4.65	180.1 – 190.0	8.55
60.1 – 70.0	5.05	190.1 – 200.0	8.75
70.1 – 80.0	5.45	200.1 – 210.0	9.00
80.1 – 90.0	5.80	210.1 – 220.0	9.20
90.1 – 100.0	6.10	220.1 – 230.0	9.40
100.1 – 110.0	6.45	230.1 – 240.0	9.65
110.1 – 120.0	6.70	240.1 – 250.0	9.85
120.1 – 130.0	7.00	250.1 – 260.0	10.05
130.1 – 140.0	7.30	260.1 – 270.0	10.25
140.1 – 150.0	7.55	270.1 – 280.0	10.40
150.1 – 160.0	7.80	280.1 – 290.0	10.60
160.1 – 170.0	8.05	290.1 – 300.0	10.80
170.1 – 180.0	8.30		

If more than one package, overpack or freight container is placed in the aircraft, the minimum separation distance for each individual package, overpack or freight container must be determined in accordance with the above table, on the basis of the sum of the transport index numbers of the individual packages, overpacks or freight containers. Alternatively, if the packages, overpacks or freight containers are separated into groups, the minimum distance from the nearest inside surface of the flight deck partition or floor to each group is the distance applicable to the sum of transport indexes within the individual groups, provided that each group is separated from each other group by at least three times the distance applicable to the one that has the larger sum of transport indexes.

Note.— For smaller sums of transport indexes, see Table 7-3. Distances for total sum of transport indexes over 200 apply to exclusive use only.

Table 7-5. Aircraft activity limits for LSA material and SCO in industrial packages

<i>Nature of material</i>	<i>Activity limit for aircraft</i>
LSA-I	No limit
LSA-II and LSA-III non-combustible solids	No limit
LSA-II and LSA-III combustible solids, and all liquids and gases	100 A ₂
SCO	100 A ₂

Table 7-6. Transport index limits for freight containers and aircraft not under exclusive use

<i>Type of freight container or aircraft</i>	<i>Limit on total sum of transport indexes in a freight container or aboard an aircraft</i>
≠ Freight container	
Small freight container	50
Large freight container	50
Aircraft	
Passenger	50
Cargo	200

Table 7-7. Critical safety indexes limits for freight containers and aircraft containing fissile material

<i>Type of freight container or aircraft</i>	<i>Limit on total sum of criticality safety indexes in a freight container or aboard an aircraft</i>	
	<i>Not under exclusive use</i>	<i>Under exclusive use</i>
≠ Freight container		
Small freight container	50	n.a.
Large freight container	50	100
Aircraft		
Passenger	50	n.a.
Cargo	50	100

≠ 2.9.4.2 Where the total sum of the criticality safety indexes on board an aircraft or in a freight container exceeds 50, as permitted in Table 7-7, storage must be such as to maintain a spacing of at least 6 m from other groups of packages, overpacks or freight containers containing fissile material or other conveyances carrying radioactive material.

+ 2.9.4.3 Fissile material meeting one of the provisions in a) to f) of 2;7.2.3.5.1 must meet the following requirements:

- only one of the provisions in a) to f) of 2;7.2.3.5.1 is allowed per consignment;
- only one approved fissile material in packages classified in accordance with 2;7.2.3.5.1 f) is allowed per consignment unless multiple materials are authorized in the certificate of approval;
- fissile material in packages classified in accordance with 2;7.2.3.5.1 c) must be transported in a consignment with no more than 45 g of fissile nuclides;

- d) fissile material in packages classified in accordance with 2;7.2.3.5.1 d) must be transported in a consignment with no more than 15 g of fissile nuclides;
- e) fissile material classified in accordance with 2;7.2.3.5.1 e) must be transported under exclusive use on an aircraft with no more than 45 g of fissile nuclides.

2.9.5 Transport by air

2.9.5.1 Type B(M) packages and consignments under exclusive use must not be transported on passenger aircraft.

2.9.5.2 Vented Type B(M) packages, packages which require external cooling by an ancillary cooling system, packages subject to operational controls during transport, and packages containing liquid pyrophoric materials must not be transported by air.

2.9.5.3 Packages or overpacks having a surface radiation level greater than 2 mSv/h must not be transported by air except by special arrangement.

2.9.5.4 Except in the case of shipment under special arrangement, mixing of packages of different kinds of radioactive material, including fissile material, and mixing of different kinds of packages with different transport indexes is permitted without specific competent authority approval. In the case of shipments under special arrangement, mixing is not permitted except as specifically authorized under the special arrangement.

2.9.6 Separation

2.9.6.1 Separation from persons

Categories II — Yellow and III — Yellow packages, overpacks or freight containers must be separated from persons. The minimum separation distances to be applied are shown in Tables 7-3 and 7-4 and these distances are from the surface of the packages, overpacks or freight containers to the nearest inside surface of the passenger cabin or flight deck partitions or floors, irrespective of the duration of the carriage of the radioactive material. Table 7-4 applies only when radioactive material is being carried by a cargo aircraft, and in those circumstances the minimum distances must be applied as above and also to any other areas occupied by persons.

2.9.6.2 Separation from undeveloped photographic film

Categories II — Yellow and III — Yellow packages, overpacks or freight containers must be separated from undeveloped photographic films or plates. The minimum separation distances to be applied are shown in Table 7-8 and these distances are from the surface of the packages, overpacks or freight containers to the surface of the packages of undeveloped photographic films or plates.

2.9.6.3 Separation from live animals

Categories II — Yellow and III — Yellow packages, overpacks or freight containers must be separated from live animals by a distance of at least 0.5 metres for journeys not exceeding 24 hours, and by a distance of at least 1.0 metres for journeys longer than 24 hours.

2.10 LOADING OF MAGNETIZED MATERIAL

Magnetized material must be loaded so that headings of aircraft compasses are maintained within the tolerances prescribed by the applicable aircraft airworthiness requirements and, where practical, in locations minimizing possible effects on compasses. Multiple packages may produce a cumulative effect. For magnetized material transported under the conditions of an approval described in Packing Instruction 953, loading must be in accordance with conditions specified in the authorizing approval.

Note.— Masses of ferro-magnetic metals such as automobiles, automobile parts, metal fencing, piping and metal construction material, even if not meeting the definition of magnetized materials may affect aircraft compasses, as may packages or items which individually do not meet the definition of magnetized material but cumulatively may have a magnetic field strength of a magnetized material.

Table 7-8. Minimum distance in metres from surface of each package, overpack or freight container of radioactive material to undeveloped photographic films or plates, for carriage lasting up to 48 hours

Total sum of transport indexes	Duration of carriage					
	2 hours or less	2-4 hours	4-8 hours	8-12 hours	12-24 hours	24-48 hours
1	0.4	0.6	0.9	1.1	1.5	2.2
2	0.6	0.8	1.2	1.5	2.2	3.1
3	0.7	1.0	1.5	1.8	2.6	3.8
4	0.8	1.2	1.7	2.2	3.1	4.4
5	0.8	1.3	1.9	2.4	3.4	4.8
10	1.4	2.0	2.8	3.5	4.9	6.9
20	2.0	2.8	4.0	4.9	6.9	10.0
30	2.4	3.5	4.9	6.0	8.6	12.0
40	2.9	4.0	5.7	6.9	10.0	14.0
50	3.2	4.5	6.3	7.9	11.0	16.0

Note.— The above is calculated so that the radiation dose received by the films does not exceed 0.1 mSv (10 mrem).

2.11 LOADING OF DRY ICE

2.11.1 Dry ice (carbon dioxide, solid), when shipped by itself or when used as a refrigerant for other commodities, may be carried provided the operator has made suitable arrangements dependent on the aircraft type, the aircraft ventilation rates, the method of packing and stowing, whether animals will be carried on the same flight, and other factors. The operator must ensure that ground staff are informed that the dry ice is being loaded or is on board the aircraft.

2.11.2 Where dry ice is contained in a unit load device or other type of pallet prepared by a single shipper in accordance with Packing Instruction 954 and the operator, after acceptance, adds additional dry ice, then the operator must ensure that the information provided to the pilot-in-command reflects that revised quantity of dry ice.

Note.— For arrangements between the shipper and operator see Packing Instruction 954.

2.12 LOADING OF UN 2211, POLYMERIC BEADS, EXPANDABLE OR UN 3314, PLASTICS MOULDING COMPOUND

A total of not more than 100 kg net mass of expandable polymeric beads (or granules), or plastic moulding materials, referenced to Packing Instruction 957, may be carried in any inaccessible hold on any aircraft.

2.13 HANDLING OF SELF-REACTIVE SUBSTANCES AND ORGANIC PEROXIDES

During the course of transport, packages or unit load devices containing self-reactive substances of Division 4.1 or organic peroxides of Division 5.2 must be shaded from direct sunlight, stored away from all sources of heat in a well-ventilated area.

2.14 HANDLING AND LOADING OF INTERMEDIATE BULK CONTAINERS (IBCs)

During handling and loading of intermediate bulk containers (IBCs), account must be taken of the IBC markings specified in 6;2.4.3, if present.

Chapter 3

INSPECTION AND DECONTAMINATION

*Parts of this Chapter are affected by State Variations AE 4, CA 4, FR 4, IT 4;
see Table A-1*

3.1 INSPECTION FOR DAMAGE OR LEAKAGE

3.1.1 It is the operator's responsibility to ensure that a package or overpack containing dangerous goods is not loaded onto an aircraft or into a unit load device unless it has been inspected immediately prior to loading and found free from evidence of leakage or damage.

3.1.2 A unit load device must not be loaded aboard an aircraft unless the device has been inspected and found free from any evidence of leakage from or damage to any dangerous goods contained therein.

3.1.3 Packages or overpacks containing dangerous goods must be inspected for signs of damage or leakage upon unloading from the aircraft or unit load device. If evidence of damage or leakage is found, the position where the dangerous goods or unit load device was stowed on the aircraft must be inspected for damage or contamination and any hazardous contamination removed. The special responsibilities of operators regarding infectious substances are detailed in 3.1.4.

3.1.4 If any person responsible for the carriage of packages containing infectious substances becomes aware of damage to or leakage from such a package, that person must:

- a) avoid handling the package or keep handling to a minimum;
- b) inspect adjacent packages for contamination and put aside any that may have been contaminated;
- c) inform the appropriate public health authority or veterinary authority and provide information on any other countries of transit where persons may have been exposed to danger;
- d) notify the shipper and/or the consignee.

3.2 DAMAGED OR LEAKING PACKAGES OF RADIOACTIVE MATERIAL, CONTAMINATED PACKAGINGS

3.2.1 If it is evident that a package is damaged or leaking, or if it is suspected that the package may have leaked or been damaged, access to the package must be restricted and a qualified person must, as soon as possible, assess the extent of contamination and the resultant radiation level of the package. The scope of the assessment must include the package, the aircraft, the adjacent loading and unloading areas and, if necessary, all other material which has been carried in the aircraft. When necessary, additional steps for the protection of persons' property and the environment, in accordance with provisions established by the relevant competent authority, must be taken to overcome and minimize the consequences of such leakage or damage.

3.2.2 Packages damaged or leaking radioactive contents in excess of allowable limits for normal conditions of transport may be removed to an acceptable interim location under supervision, but must not be forwarded until repaired or reconditioned and decontaminated.

3.2.3 An aircraft and equipment used regularly for the transport of radioactive material must be periodically checked to determine the level of contamination. The frequency of such checks must be related to the likelihood of contamination and the extent to which radioactive material is transported.

≠ 3.2.4 Except as provided in 3.2.5, any aircraft or equipment or part thereof which has become contaminated above the limits specified in 4;9.1.2 in the course of the transport of radioactive material, or which shows a radiation level in excess of 5 µSv/h at the surface, must be decontaminated as soon as possible by a qualified person and must not be re-used unless the following conditions are met:

- ≠ a) the non-fixed contamination must not exceed the limits specified in 4;9.1.2; and
- ≠ b) the radiation level resulting from the fixed contamination must not exceed 5 µSv/h at the surface.

3.2.5 An overpack, freight container, or aircraft dedicated to the transport of radioactive material under exclusive use must be excepted from the requirements of 4:9.1.4 and 3.2.4 solely with regard to its internal surfaces and only for as long as it remains under that specific exclusive use.

3.3 DEALING WITH SUSPECTED CONTAMINATED BAGGAGE OR CARGO

If an operator becomes aware that baggage or cargo not identified as containing dangerous goods has been contaminated and it is suspected that dangerous goods may be the cause of the contamination, the operator must take reasonable steps to identify the nature and source of the contamination before proceeding with the loading of the contaminated baggage or cargo. If the contaminating substance is found or suspected to be a substance classified as dangerous goods by these Instructions, the operator must isolate the baggage or cargo and take appropriate steps to nullify any identified hazard before the baggage or cargo is transported further by air.

Chapter 4

PROVISION OF INFORMATION

Parts of this Chapter are affected by State Variations AU 4, CA 4, CA 12, FR 5, GB 4, KP 3, MY 4, MY 5, US 12, US 13, US 15, VU 3, VU 4; see Table A-1

INTRODUCTORY NOTE

Operators' responsibilities for the provision of information to passengers are shown in Part 8.

4.1 INFORMATION TO THE PILOT-IN-COMMAND

4.1.1 As early as practicable before departure of the aircraft, but in no case later than when the aircraft moves under its own power, the operator of an aircraft in which dangerous goods are to be carried must:

- a) provide the pilot-in-command with accurate and legible written or printed information concerning dangerous goods that are to be carried as cargo; and
- ≠ b) provide personnel with responsibilities for operational control of the aircraft (e.g. the flight operations officer, flight dispatcher, or designated ground personnel responsible for flight operations) with the same information that is required to be provided to the pilot-in-command (e.g. a copy of the written information provided to the pilot-in-command). Each operator must specify the personnel (job title or function) to be provided this information in their operations manual and/or other appropriate manuals.

For helicopter operations, with the approval of the State of the Operator, the information provided to the pilot-in-command may be abbreviated or be by other means (e.g. radio communication, as part of the working flight documentation such as a journey log or operational flight plan) where circumstances make it impractical to produce written or printed information or on a dedicated form (see Part S-7;4.8 of the Supplement).

Note 1.— This includes information about dangerous goods loaded at a previous departure point and which are to be carried on the subsequent flight.

Note 2.— Information required under 4;1.1 b) should be readily available to the operator's personnel whose responsibilities most closely align with the duties of the flight operations officer/flight dispatcher described in Annex 6, Part I, Chapter 4, 4.6. These personnel are intended to provide the information required by 4.6 to facilitate emergency response.

Note 3.— The provision in 4.1.1 b) is recommended until 1 January 2014 when it will become mandatory.

- ≠ 4.1.1.1 Except as otherwise provided, the information required by 4.1.1 must include the following:
 - a) the air waybill number (when issued);
 - ≠ b) the proper shipping name (the technical name(s) shown on the dangerous goods transport document is not required) and UN Number or ID number as listed in these Instructions. When chemical oxygen generators contained in protective breathing equipment (PBE) are being transported under Special Provision A144, the proper shipping name of "oxygen generator, chemical" must be supplemented with the statement "Aircrew protective breathing equipment (smoke hood) in accordance with Special Provision A144".
 - c) the class or division, and subsidiary risk(s) corresponding to the subsidiary risk label(s) applied, by numerals, and in the case of Class 1, the compatibility group;
 - d) the packing group shown on the dangerous goods transport document;
 - e) the number of packages and their exact loading location. For radioactive material see g) below;
 - f) the net quantity, or gross mass if applicable, of each package, except that this does not apply to radioactive material or other dangerous goods where the net quantity or gross mass is not required on the dangerous goods transport document (see 5;4.1.4) or, when applicable, alternative written documentation. For a consignment consisting of multiple packages containing dangerous goods bearing the same proper shipping name and UN number or ID number, only the total quantity and an indication of the quantity of the largest and smallest package at each loading location need to be provided. For unit load devices or other types of pallets containing consumer commodities accepted from a single shipper, the number of packages and the average gross mass need to be provided;

- g) for radioactive material the number of packages, overpacks or freight containers, their category, their transport index (if applicable) and their exact loading location;
- h) whether the package must be carried on cargo aircraft only;
- i) the aerodrome at which the package(s) is to be unloaded;
- j) where applicable, an indication that the dangerous goods are being carried under a State exemption; and
- k) the telephone number where a copy of the information provided to the pilot-in-command can be obtained during the flight if the operator allows the pilot-in-command to provide a telephone number instead of the details about the dangerous goods on board the aircraft, as specified in 4.3.

≠ 4.1.2 For UN 1845 — **Carbon dioxide, solid** (dry ice), the information required by 4.1.1 may be replaced by the UN number, proper shipping name, class, total quantity in each hold on the aircraft and the aerodrome at which the package(s) is to be unloaded.

≠ 4.1.3 For UN 3480 (**Lithium ion batteries**) and UN 3090 (**Lithium metal batteries**), the information required by 4.1.1 may be replaced by the UN number, proper shipping name, class, total quantity at each specific loading location, and whether the package must be carried on cargo aircraft only. UN 3480 (**Lithium ion batteries**) and UN 3090 (**Lithium metal batteries**) carried under a State exemption must meet all of the requirements of 4.1.

4.1.4 The information provided to the pilot-in-command must also include a signed confirmation, or some other indication, from the person responsible for loading the aircraft that there was no evidence of any damage to or leakage from the packages or any leakage from the unit load devices loaded on the aircraft.

4.1.5 The information provided to the pilot-in-command must be readily available to the pilot-in-command during flight.

4.1.6 This information provided to the pilot-in-command should be presented on a dedicated form and should not be by means of air waybills, dangerous goods transport documents, invoices, etc.

4.1.7 The pilot-in-command must indicate on a copy of the information provided to the pilot-in-command, or in some other way, that the information has been received.

4.1.8 A legible copy of the information provided to the pilot-in-command must be retained on the ground. This copy must have an indication on it, or with it, that the pilot-in-command has received the information. A copy, or the information contained in it, must be readily accessible to the flight operations officer, flight dispatcher, or designated ground personnel responsible for flight operations until after the arrival of the flight.

4.1.9 In addition to the languages which may be required by the State of the Operator, English should be used for the information provided to the pilot-in-command.

4.1.10 In the event that the volume of information provided to the pilot-in-command is such that in-flight radiotelephony transmission would be impracticable in an emergency situation, a summary of the information should also be provided by the operator, containing at least the quantities and class or division of the dangerous goods in each cargo compartment.

4.1.11 The dangerous goods listed in Table 7-9 need not appear on the information provided to the pilot-in-command.

Table 7-9. Dangerous goods not required to appear in the information to the pilot-in-command

<i>UN Number</i>	<i>Item</i>	<i>Reference</i>
n/a	Dangerous goods packed in excepted quantities	3;5.1.1
UN 2807	Magnetized material	Packing Instruction 953
UN 2908	Radioactive material, excepted package — empty packaging	1;6.1.5.1 a)
UN 2909	Radioactive material, excepted package — articles manufactured from natural uranium or depleted uranium or natural thorium	1;6.1.5.1 a)
UN 2910	Radioactive material, excepted package — limited quantity of material	1;6.1.5.1 a)
UN 2911	Radioactive material, excepted package — instruments or articles	1;6.1.5.1 a)
UN 3090	Lithium metal batteries (including lithium alloy batteries) when meeting the requirements of Packing Instruction 968, Section II	Packing Instruction 968, Section II
UN 3091	Lithium metal batteries contained in equipment (including lithium alloy batteries) when meeting the requirements of Packing Instruction 970, Section II	Packing Instruction 970, Section II

<i>UN Number</i>	<i>Item</i>	<i>Reference</i>
UN 3091	Lithium metal batteries packed with equipment (including lithium alloy batteries) when meeting the requirements of Packing Instruction 969, Section II	Packing Instruction 969, Section II
UN 3245	Genetically modified micro-organisms	Packing Instruction 959
UN 3245	Genetically modified organisms	Packing Instruction 959
UN 3373	Biological substance, Category B	Packing Instruction 650, sub-paragraph 11
UN 3480	Lithium ion batteries (including lithium ion polymer batteries) when meeting the requirements of Packing Instruction 965, Section II	Packing Instruction 965, Section II
UN 3481	Lithium ion batteries contained in equipment (including lithium ion polymer batteries) when meeting the requirements of Packing Instruction 967, Section II	Packing Instruction 967, Section II
UN 3481	Lithium ion batteries packed with equipment (including lithium ion polymer batteries) when meeting the requirements of Packing Instruction 966, Section II	Packing Instruction 966, Section II

4.2 INFORMATION TO BE PROVIDED TO EMPLOYEES

An operator must provide such information in the operations manual and/or other appropriate manuals as will enable flight crews and other employees to carry out their responsibilities with regard to the transport of dangerous goods. This information must include instructions as to the action to be taken in the event of emergencies involving dangerous goods, and details of the location and numbering system of cargo compartments together with:

- a) the maximum quantity of dry ice permitted in each compartment; and
- b) if radioactive material is to be carried, instructions on the loading of such dangerous goods based on the requirements of 7;2.9.

Where applicable, this information must also be provided to ground handling agents.

4.3 INFORMATION TO BE PROVIDED BY THE PILOT-IN-COMMAND IN CASE OF IN-FLIGHT EMERGENCY

If an in-flight emergency occurs, the pilot-in-command must, as soon as the situation permits, inform the appropriate air traffic services unit, for the information of aerodrome authorities, of any dangerous goods carried as cargo on board an aircraft. Wherever possible this information should include the proper shipping name and/or UN number, the class/division and, for Class 1, the compatibility group, any identified subsidiary risk(s), the quantity and the location on board the aircraft, or a telephone number where a copy of the information provided to the pilot-in-command can be obtained. When it is not considered possible to include all the information, those parts thought most relevant in the circumstances or a summary of the quantities and class or division of dangerous goods in each cargo compartment should be given.

4.4 REPORTING OF DANGEROUS GOODS ACCIDENTS AND INCIDENTS

An operator must report dangerous goods accidents and incidents to the appropriate authorities of the State of the Operator and the State in which the accident or incident occurred in accordance with the reporting requirements of those appropriate authorities.

Note.— This includes incidents involving dangerous goods that are not subject to all or part of these Instructions through the application of an exception or of a special provision (e.g. an incident involving the short circuiting of a dry cell battery that is required to meet short-circuit prevention conditions in a special provision of 3;3).

4.5 REPORTING OF UNDECLARED OR MISDECLARED DANGEROUS GOODS

An operator must report any occasion when undeclared or misdeclared dangerous goods are discovered in cargo or mail. Such a report must be made to the appropriate authorities of the State of the Operator and the State in which this occurred. An operator must also report any occasion when dangerous goods not permitted under 8;1.1.1 are discovered, either in the baggage or on the person, of passengers or crew members. Such a report must be made to the appropriate authority of the State in which this occurred.

4.6 REPORTING OF DANGEROUS GOODS OCCURRENCES

An operator must report to the State of the Operator and the State of Origin any occasion when:

- a) dangerous goods are discovered to have been carried when not loaded, segregated, separated or secured in accordance with Part 7;2; or
- b) dangerous goods are discovered to have been carried without information having been provided to the pilot-in-command in accordance with Part 7;4.1.

4.7 INFORMATION BY THE OPERATOR IN CASE OF AN AIRCRAFT ACCIDENT OR INCIDENT

4.7.1 In the event of:

- a) an aircraft accident; or
- b) a serious incident where dangerous goods carried as cargo may be involved,

the operator of the aircraft carrying dangerous goods as cargo must, without delay, provide to emergency services responding to the accident or serious incident, information about the dangerous goods on board, as shown on the copy of the information provided to the pilot-in-command. As soon as possible, the operator must also provide this information to the appropriate authorities of the State of the Operator and the State in which the accident or serious incident occurred.

4.7.2 In the event of an aircraft incident, if requested to do so, the operator of an aircraft carrying dangerous goods as cargo must, without delay, provide to emergency services responding to the incident and to the appropriate authority of the State in which the incident occurred, information about the dangerous goods on board, as shown on the copy of the information provided to the pilot-in-command.

Note.— The terms “accident”, “serious incident” and “incident” are as defined in Annex 13.

4.7.3 Operators must address the provisions of 4.7.1 and 4.7.2 in appropriate manuals and accident contingency plans.

4.8 CARGO ACCEPTANCE AREAS — PROVISION OF INFORMATION

An operator or the operator's handling agent must ensure that notices giving information about the transport of dangerous goods are sufficient in number, prominently displayed and provided at a visible location(s) at the cargo acceptance points to alert shippers/agents about any dangerous goods that may be contained in their cargo consignment(s). These notices must include visual examples of dangerous goods, including batteries.

4.9 EMERGENCY RESPONSE INFORMATION

The operator must ensure that for consignments for which a dangerous goods transport document is required by these Instructions, appropriate information is immediately available at all times for use in emergency response to accidents and incidents involving dangerous goods in air transport. The information must be available to the pilot-in-command and can be provided by:

- a) the ICAO document *Emergency Response Guidance for Aircraft Incidents Involving Dangerous Goods* (Doc 9481); or
- b) any other document which provides appropriate information concerning the dangerous goods on board.

4.10 TRAINING

- ≠ An operator must ensure training is provided in accordance with the detailed requirements of 1;4 to all relevant employees, including those of agencies employed to act on the operator's behalf, to enable them to carry out their responsibilities with regard to the transport of dangerous goods, passengers and their baggage, cargo and mail.

4.11 RETENTION OF DOCUMENTS OR INFORMATION

≠ 4.11.1 The operator must ensure that at least one copy of the documents or information appropriate to the transport by air of a consignment of dangerous goods is retained for a minimum period of three months after the flight on which the dangerous goods were transported. As a minimum, the documents or information which must be retained are the dangerous goods transport documents, the acceptance checklist (when this is in a form which requires physical completion) and the written information to the pilot-in-command. These documents or the information must be made available to the appropriate national authority upon request.

4.11.2 For each package or overpack containing dangerous goods or freight container containing radioactive material or unit load device or other type of pallet containing dangerous goods as described in 1.4 that was not accepted by an operator due to an error or omission by the shipper in packaging, labelling, marking or documentation, a copy of the documentation as well as the acceptance checklist (when this is in a form which requires physical completion) should be retained for a minimum period of three months after the completion of the acceptance checklist.

Note.— Where the documents are kept electronically or in a computer system, they should be capable of being reproduced in a printed manner.

Chapter 5

PROVISIONS CONCERNING PASSENGERS AND CREW

5.1 INFORMATION TO PASSENGERS

≠ 5.1.1 An operator must ensure that information on the types of dangerous goods which a passenger is forbidden to transport aboard an aircraft is presented at the point of ticket purchase or, if this is not practical, made available in another manner to passengers prior to the check-in process. Information provided via the Internet may be in text or pictorial form but must be such that ticket purchase cannot be completed until the passenger, or a person acting on their behalf, has been presented with this information and indicated that they have understood the restrictions on dangerous goods in baggage.

5.1.2 An operator or the operator's handling agent and the airport operator must ensure that notices warning passengers of the types of dangerous goods which they are forbidden to transport aboard an aircraft are prominently displayed, in sufficient number, at each of the places at an airport where tickets are issued, passengers are checked in and aircraft boarding areas are maintained, and at any other location where passengers are checked in. These notices must include visual examples of dangerous goods forbidden from transport aboard an aircraft.

5.1.3 An operator, of passenger aircraft, should have information on those dangerous goods which may be carried by passengers in accordance with 8;1.1.2 made available prior to the check-in process on their websites or other sources of information.

≠ 5.1.4 When provision is made for the check-in process to be completed remotely (e.g. via the Internet), the operator must ensure that information on the types of dangerous goods which a passenger is forbidden to transport aboard an aircraft is presented to passengers. Information may be in text or pictorial form but must be such that the check-in process cannot be completed until the passenger, or a person acting on their behalf, has been presented with this information and indicated that they have understood the restrictions on dangerous goods in baggage.

≠ 5.1.5 When provision is made for the check-in process to be completed at an airport by a passenger without the involvement of any other person (e.g. automated check-in facility), the operator or the airport operator must ensure that information on the types of dangerous goods which a passenger is forbidden to transport aboard an aircraft is presented to passengers. Information should be in pictorial form and must be such that the check-in process cannot be completed until the passenger has been presented with this information and indicated that they have understood the restrictions on dangerous goods in baggage.

5.2 PASSENGER CHECK-IN PROCEDURES

5.2.1 Operators' check-in staff must be adequately trained to assist them in identifying and detecting dangerous goods carried by passengers other than as permitted in 8;1.1.2.

5.2.2 With the aim of preventing dangerous goods, which passengers are not permitted to have, from being taken aboard an aircraft in passengers' baggage or on their person, check-in staff should seek confirmation from a passenger that they are not carrying dangerous goods that are not permitted, and seek further confirmation about the contents of any item where there are suspicions that it may contain dangerous goods that are not permitted. Many innocuous-looking items may contain dangerous goods, and a list of general descriptions which, experience has shown, often apply to such items is shown in 7;6.

5.2.3 With the aim of preventing dangerous goods, which a passenger is not permitted to have, from being taken aboard an aircraft in excess baggage consigned as cargo, any organization or enterprise accepting excess baggage consigned as cargo should seek confirmation from the passenger, or a person acting on behalf of the passenger, that the excess baggage does not contain dangerous goods that are not permitted and seek further confirmation about the contents of any item where there are suspicions that it may contain dangerous goods that are not permitted.

Chapter 6

PROVISIONS TO AID RECOGNITION OF UNDECLARED DANGEROUS GOODS

≠ 6.1 With the aim of preventing undeclared dangerous goods from being loaded on an aircraft and of preventing passengers from taking on board those dangerous goods which they are not permitted to have in their baggage (see Table 8-1), information about:

- a) general descriptions that are often used for items in cargo or in passengers' baggage which may contain dangerous goods;
- b) other indications that dangerous goods may be present (e.g. labels, markings); and

≠ c) those dangerous goods which may be carried by passengers in accordance with Table 8-1,

must be provided to cargo reservations and sales staff, cargo acceptance staff, passenger reservations and sales staff and passenger check-in staff as appropriate and must be readily available to such staff. The following is a list of general descriptions and the types of dangerous goods that may be included in any item bearing that description.

aircraft on ground (AOG) spares — may contain explosives (flares or other pyrotechnics), chemical oxygen generators, unserviceable tire assemblies, cylinders of compressed gas (oxygen, carbon dioxide or fire extinguishers), fuel in equipment, wet or lithium batteries, matches

≠ *automobile parts/supplies (car, motor, motorcycle)* — may include engines, including fuel cell engines, carburetors or fuel tanks that contain or have contained fuel, wet or lithium batteries, compressed gases in tire inflation devices and fire extinguishers, air bags, flammable adhesives, paints, sealants and solvents, etc.

+ *battery-powered devices/equipment* — may contain wet or lithium batteries.

breathing apparatus — may indicate cylinders of compressed air or oxygen, chemical oxygen generators or refrigerated liquefied oxygen

camping equipment — may contain flammable gases (butane, propane, etc.), flammable liquids (kerosene, gasoline, etc.) or flammable solids (hexamine, matches, etc.)

cars, car parts — see automobile parts, etc.

chemicals — may contain items meeting any of the criteria for dangerous goods, particularly flammable liquids, flammable solids, oxidizers, organic peroxides, toxic or corrosive substances

consolidated consignments (groupages) — may contain any of the defined classes of dangerous goods

cryogenic (liquid) — indicates refrigerated liquefied gases such as argon, helium, neon, nitrogen, etc.

cylinders — may contain compressed or liquefied gas

dental apparatus — may contain flammable resins or solvents, compressed or liquefied gas, mercury and radioactive material

diagnostic specimens — may contain infectious substances

diving equipment — may contain cylinders of compressed gas (e.g. air or oxygen). May also contain high intensity diving lamps that can generate extreme heat when operated in air. In order to be carried safely, the bulb or battery should be disconnected

drilling and mining equipment — may contain explosive(s) and/or other dangerous goods

dry shipper (vapour shipper) — may contain free liquid nitrogen. Dry shippers are not subject to these Instructions only when they do not permit the release of any free liquid nitrogen irrespective of the orientation of the packaging

≠ *electrical/electronic equipment* — may contain magnetized material, mercury in switch gear, electron tubes, wet or lithium batteries or fuel cells or fuel cell cartridges that contain or have contained fuel

≠ *electrically powered apparatus (wheelchairs, lawnmowers, golf carts, etc.)* — may contain wet or lithium batteries or fuel cells or fuel cell cartridges that contain or have contained fuel

- expeditionary equipment* — may contain explosives (flares), flammable liquids (gasoline), flammable gas (gas for camping equipment) or other dangerous goods
- ≠ *film crew and media equipment* — may contain explosive pyrotechnic devices, generators incorporating internal combustion engines, wet or lithium batteries, fuel, heat-producing items, etc.
- frozen embryos* — may be packed in refrigerated liquefied gas or dry ice
- frozen fruit, vegetables, etc.* — may be packed in dry ice (solid carbon dioxide)
- fuel control units* — may contain flammable liquids
- hot-air balloon* — may contain cylinders with flammable gas, fire extinguishers, engines internal combustion, batteries, etc.
- ≠ *household goods* — may contain items meeting any of the criteria for dangerous goods. Examples include flammable liquids such as solvent-based paint, adhesives, polishes, aerosols (for passengers, those not permitted under Table 8-1), bleach, corrosive oven or drain cleaners, ammunition, matches, etc.
- instruments* — may conceal barometers, manometers, mercury switches, rectifier tubes, thermometers, etc., containing mercury
- ≠ *laboratory/testing equipment* — may contain items meeting any of the criteria for dangerous goods, particularly flammable liquids, flammable solids, oxidizers, organic peroxides, toxic or corrosive substances, lithium batteries, cylinders of compressed gas, etc.
- machinery parts* — may contain flammable adhesives, paints, sealants and solvents, wet and lithium batteries, mercury, cylinders of compressed or liquefied gas, etc.
- ≠ *magnets and other items of similar material* — may individually or cumulatively meet the definition of magnetized material (see 2;9.2.1 d))
- ≠ *medical supplies/equipment* — may contain items meeting any of the criteria for dangerous goods, particularly flammable liquids, flammable solids, oxidizers, organic peroxides, toxic or corrosive substances, lithium batteries
- ≠ *metal construction material* — may contain ferromagnetic material which may be subject to special stowage requirements due to the possibility of affecting aircraft instruments (see 2;9.2.1 d))
- ≠ *metal fencing* — may contain ferromagnetic material which may be subject to special stowage requirements due to the possibility of affecting aircraft instruments (see 2;9.2.1 d))
- ≠ *metal piping* — may contain ferromagnetic material which may be subject to special stowage requirements due to the possibility of affecting aircraft instruments (see 2;9.2.1 d))
- ≠ *passengers' baggage* — may contain items meeting any of the criteria for dangerous goods not permitted under Table 8-1
- pharmaceuticals* — may contain items meeting any of the criteria for dangerous goods, particularly radioactive material, flammable liquids, flammable solids, oxidizers, organic peroxides, toxic or corrosive substances
- ≠ *photographic supplies/equipment* — may contain items meeting any of the criteria for dangerous goods, particularly heat-producing devices, flammable liquids, flammable solids, oxidizers, organic peroxides, toxic or corrosive substances, lithium batteries
- ≠ *racing car or motorcycle team equipment* — may contain engines, including fuel cell engines, carburetors or fuel tanks that contain fuel or residual fuel, wet and lithium batteries, flammable aerosols, nitromethane or other gasoline additives, cylinders of compressed gases, etc.
- refrigerators* — may contain liquefied gases or an ammonia solution
- repair kits* — may contain organic peroxides and flammable adhesives, solvent-based paints, resins, etc.
- samples for testing* — may contain items meeting any of the criteria for dangerous goods, particularly infectious substances, flammable liquids, flammable solids, oxidizers, organic peroxides, toxic or corrosive substances
- semen* — may be packed with dry ice or refrigerated liquefied gas (see also dry shipper)
- ships' spares* — may contain explosives (flares), cylinders of compressed gas (life rafts), paint, lithium batteries (emergency locator transmitters), etc.
- + *sporting goods/sports team equipment* — may contain cylinders of compressed or liquefied gas (air, carbon dioxide, etc.), lithium batteries, propane torches, first aid kits, flammable adhesives, aerosols, etc.

swimming pool chemicals — may contain oxidizing or corrosive substances

switches in electrical equipment or instruments — may contain mercury

- ≠ *tool boxes* — may contain explosives (power rivets), compressed gases or aerosols, flammable gases (Butane cylinders or torches), flammable adhesives or paints, corrosive liquids, lithium batteries, etc.

torches — micro torches and utility lighters may contain flammable gas and be equipped with an electronic starter. Larger torches may consist of a torch head (often with a self-igniting switch) attached to a container or cylinder of flammable gas

- ≠ *unaccompanied passengers' baggage/personal effects* — may contain items meeting any of the criteria for dangerous goods not permitted under Table 8-1

Note. — *Excess baggage carried as cargo may contain certain dangerous goods, as provided for by 1;1.1.5.1 g).*

vaccines — may be packed in dry ice (solid carbon dioxide)

Chapter 7

HELICOPTER OPERATIONS

Note.— The requirements in this chapter are in addition to the other provisions of these Instructions that apply to all operators (e.g. Part 7 and Part 1;4).

7.1.1 Due to the differences in the type of operations carried out by helicopters compared with aeroplanes, there may be circumstances when the full provisions of these Instructions are not appropriate or necessary, due to the operations involving unmanned sites, remote locations, mountainous areas or construction sites, etc. In such circumstances and when appropriate, the State of the Operator may grant an approval in order to permit the carriage of dangerous goods without all of the normal requirements of these Instructions being fulfilled. When States other than the State of the Operator have notified ICAO that they require prior approval of such operations, approval must also be obtained from the States of Origin and destination, as appropriate.

7.1.2 When loading dangerous goods for open external carriage by a helicopter, consideration should also be given to the type of packaging used and to the protection of those packagings, where necessary, from the effects of airflow and weather (e.g. by damage from rain or snow), in addition to the general loading provisions of 7;2.

7.1.3 When dangerous goods are carried suspended from a helicopter, the operator must ensure that consideration is given to the dangers of static discharge upon landing or release of the load.

7.1.4 When helicopters are carrying passengers, in accordance with Part S-7;2.2.4 of the Supplement, the State of the Operator may grant an approval to permit the carriage of dangerous goods either:

- a) in the cabin, when those dangerous goods are associated with and accompanied by the passengers; or
- b) in cargo compartments that do not meet the requirements of Part 7;2.1.1.

Part 8

**PROVISIONS CONCERNING
PASSENGERS AND CREW**

Chapter 1

PROVISIONS FOR DANGEROUS GOODS CARRIED BY PASSENGERS OR CREW

Parts of this Chapter are affected by State Variations US 15; see Table A-1

1.1 DANGEROUS GOODS CARRIED BY PASSENGERS OR CREW

1.1.1 Except as otherwise provided in 1.1.2, dangerous goods, including excepted packages of radioactive material, must not be carried by passengers or crew members, either as or in carry-on baggage or checked baggage or on their person. Except as provided for in Table 8-1, 30), security type equipment such as attaché cases, cash boxes, cash bags, etc., incorporating dangerous goods, for example lithium batteries or pyrotechnic material, are totally forbidden; see entry in Table 3-1. Personal medical oxygen devices that utilize liquid oxygen are forbidden either as or in carry-on baggage or checked baggage or on the person. Electroshock weapons (e.g. tasers) containing dangerous goods such as explosives, compressed gases, lithium batteries, etc., are forbidden in carry-on baggage or checked baggage or on the person.

≠ 1.1.2 Notwithstanding any additional restrictions which may be implemented by States in the interests of aviation security, except for the incident reporting provisions of 7;4.4 or 7;4.5, as applicable, the provisions of these Instructions do not apply to the dangerous goods listed in Table 8-1 when carried by passengers or crew members or in baggage that has been separated from its owner during transit (e.g. lost baggage or improperly routed baggage) or in excess baggage carried as cargo as permitted by 1;1.1.5.1 g):

1.1.3 Any organization or enterprise other than an operator (such as a travel agent), involved in the air transport of passengers, should provide passengers with information about the types of dangerous goods which they are forbidden to transport aboard an aircraft. This information should consist of, as a minimum, notices at those locations where there is an interface with the passengers.

1.1.4 Where provision is made for the purchase of tickets via the Internet, information on the types of dangerous goods which a passenger is forbidden to transport aboard an aircraft should be provided in either text or pictorial form and should be such that ticket purchase cannot be completed until the passenger, or a person acting on their behalf, has indicated that they have understood the restrictions on dangerous goods in baggage.

Table 8-1. Provisions for dangerous goods carried by passengers or crew

<i>Items or articles</i>	<i>Location</i>			<i>Approval of the operator(s) is required</i>	<i>The pilot-in-command must be informed</i>	<i>Restrictions</i>
	<i>Checked baggage</i>	<i>Carry-on baggage</i>	<i>On the person</i>			
Medical necessities						
1) Small gaseous oxygen or air cylinders required for medical use	Yes	Yes	Yes	Yes	Yes	a) no more than 5 kg gross mass per cylinder; b) cylinders, valves and regulators, where fitted, must be protected from damage which could cause inadvertent release of the contents; and c) the pilot-in-command must be informed of the number of oxygen or air cylinders loaded on board the aircraft and their loading location(s).
----- Devices containing liquid oxygen	No	No	No	n/a	n/a	Devices containing liquid oxygen are forbidden in carry-on baggage, checked baggage or on the person.
2) Cylinders of a gas of Division 2.2 worn for the operation of mechanical limbs	Yes	Yes	Yes	No	No	Spare cylinders of a similar size are also allowed, if required, to ensure an adequate supply for the duration of the journey.

<i>Items or articles</i>	<i>Location</i>			<i>Approval of the operator(s) is required</i>	<i>The pilot-in-command must be informed</i>	<i>Restrictions</i>
	<i>Checked baggage</i>	<i>Carry-on baggage</i>	<i>On the person</i>			
3) Non-radioactive medicinal articles (including aerosols)	Yes	Yes	Yes	No	No	<ul style="list-style-type: none"> a) no more than 0.5 kg or 0.5 L total net quantity per single article; b) release valves on aerosols must be protected by a cap or other suitable means to prevent inadvertent release of the contents; and c) no more than 2 kg or 2 L total net quantity of all articles mentioned in 3), 10) and 13) (e.g. four aerosol cans of 500 mL each) per person.
≠ 4) Radioisotopic cardiac pacemakers or other medical devices, including those powered by lithium batteries	n/a	n/a	Yes	No	No	Must be implanted into a person or fitted externally as the result of medical treatment.
Radio-pharmaceuticals contained within the body of a person	n/a	n/a	Yes	No	No	Must be as the result of medical treatment.
≠ 5) Mobility aids (e.g. wheelchairs) powered by non-spillable wet batteries or batteries which comply with Special Provision A123 or A199, for use by passengers whose mobility is restricted by either a disability, their health or age, or a temporary mobility problem (e.g. broken leg)	Yes	No	No	Yes	(see 5 d iv))	<ul style="list-style-type: none"> a) non-spillable wet batteries must comply with Special Provision A67 or the vibration and pressure differential tests of Packing Instruction 872; b) the operator must verify that: <ul style="list-style-type: none"> i) the battery is securely attached to the mobility aid; ii) the battery terminals are protected from short circuits (e.g. by being enclosed within a battery container); and iii) electrical circuits have been isolated; c) mobility aids must be carried in a manner such that they are protected from being damaged by the movement of baggage, mail, stores or other cargo; d) where the mobility aid is specifically designed to allow its battery(ies) to be removed by the user (e.g. collapsible): <ul style="list-style-type: none"> i) the battery(ies) must be removed; the mobility aid may then be carried as checked baggage without restriction; ii) the removed battery(ies) must be carried in strong, rigid packagings which must be stowed in the cargo compartment; iii) the battery(ies) must be protected from short circuit; and iv) the pilot-in-command must be informed of the location of the packed battery; e) it is recommended that passengers make advance arrangements with each operator.

<i>Items or articles</i>	<i>Location</i>			<i>Approval of the operator(s) is required</i>	<i>The pilot-in-command must be informed</i>	<i>Restrictions</i>
	<i>Checked baggage</i>	<i>Carry-on baggage</i>	<i>On the person</i>			
6) Mobility aids (e.g. wheelchairs) powered by spillable batteries, for use by passengers whose mobility is restricted by either a disability, their health or age, or a temporary mobility problem (e.g. broken leg)	Yes	No	No	Yes	Yes	<p>a) where possible, the mobility aid must be loaded, stowed, secured and unloaded always in an upright position. The operator must verify that:</p> <ul style="list-style-type: none"> i) the battery is securely attached to the mobility aid; ii) battery terminals are protected from short circuits (e.g. by being enclosed within a battery container); and iii) electrical circuits have been isolated; <p>b) if the mobility aid cannot be loaded, stowed, secured and unloaded always in an upright position, the battery(ies) must be removed and carried in strong, rigid packagings, as follows:</p> <ul style="list-style-type: none"> i) packagings must be leak-tight, impervious to battery fluid and be protected against upset by securing them to pallets or by securing them in cargo compartments using appropriate means of securement (other than by bracing with freight or baggage) such as by the use of restraining straps, brackets or holders; ii) batteries must be protected against short circuits, secured upright in these packagings and surrounded by compatible absorbent material sufficient to absorb their total liquid contents; and iii) these packagings must be marked "Battery, wet, with wheelchair" or "Battery, wet, with mobility aid" and be labelled with a "Corrosive" label (Figure 5-22) and with package orientation labels (Figure 5-26) as required by 5.3; <p>The mobility aid may then be carried as checked baggage without restriction;</p> <p>c) mobility aids must be carried in a manner such that they are protected from being damaged by the movement of baggage, mail, stores or other cargo;</p> <p>d) the pilot-in-command must be informed of the location of the mobility aid with an installed battery or the location of a packed battery;</p> <p>e) it is recommended that passengers make advance arrangements with each operator; also, unless batteries are non-spillable they should be fitted, where feasible, with spill-resistant vent caps.</p>

<i>Items or articles</i>	<i>Location</i>			<i>Approval of the operator(s) is required</i>	<i>The pilot-in-command must be informed</i>	<i>Restrictions</i>
	<i>Checked baggage</i>	<i>Carry-on baggage</i>	<i>On the person</i>			
7) Mobility aids (e.g. wheelchairs) powered by lithium ion batteries, for use by passengers whose mobility is restricted by either a disability, their health or age, or a temporary mobility problem (e.g. broken leg)	Yes	(see 7 d))	No	Yes	Yes	<p>a) the batteries must be of a type which meets the requirements of each test in the UN <i>Manual of Tests and Criteria</i>, Part III, subsection 38.3;</p> <p>b) the operator must verify that:</p> <ul style="list-style-type: none"> i) the battery is securely attached to the mobility aid; ii) the battery terminals are protected from short circuits (e.g. by being enclosed within a battery container); and iii) electrical circuits have been isolated; <p>c) mobility aids must be carried in a manner such that they are protected from being damaged by the movement of baggage, mail, stores or other cargo;</p> <p>d) where the mobility aid is specifically designed to allow its battery(ies) to be removed by the user (e.g. collapsible):</p> <ul style="list-style-type: none"> i) the battery(ies) must be removed and carried in the passenger cabin; ii) the battery terminals must be protected from short circuit (by insulating the terminals, e.g. by taping over exposed terminals); iii) the battery must be protected from damage (e.g. by placing each battery in a protective pouch); iv) removal of the battery from the mobility aid must be performed by following the instructions of the manufacturer or device owner; v) the battery must not exceed 300 Wh; and vi) a maximum of one spare battery not exceeding 300 Wh or two spares not exceeding 160 Wh each may be carried; <p>e) the pilot-in-command must be informed of the location of the lithium ion battery(ies);</p> <p>f) it is recommended that passengers make advance arrangements with each operator.</p>
8) Portable medical electronic devices (automated external defibrillators (AED), nebulizer, continuous positive airway pressure (CPAP), etc.) containing lithium metal or lithium ion cells or batteries						

<i>Items or articles</i>	<i>Location</i>			<i>Approval of the operator(s) is required</i>	<i>The pilot-in-command must be informed</i>	<i>Restrictions</i>
	<i>Checked baggage</i>	<i>Carry-on baggage</i>	<i>On the person</i>			
≠ Portable medical electronic devices containing lithium metal cells or batteries not exceeding 2 grams or lithium ion cells or batteries not exceeding 100 Wh	Yes	Yes	Yes	No	No	<ul style="list-style-type: none"> a) carried by passengers for medical use; b) each installed or spare battery must be of a type which meets the requirements of each test in the UN <i>Manual of Tests and Criteria</i>, Part III, subsection 38.3; c) spare batteries must be individually protected so as to prevent short circuits (by placement in original retail packaging or by otherwise insulating terminals, e.g. by taping over exposed terminals or placing each battery in a separate plastic bag or protective pouch); and d) no more than two spare batteries exceeding 2 grams lithium content for lithium metal or a watt-hour rating exceeding 100 Wh for lithium ion may be carried by a passenger.
≠ Spare batteries for portable medical electronic devices containing lithium metal cells or batteries not exceeding 2 grams or lithium ion cells or batteries not exceeding 100 Wh	No	Yes	Yes	No	No	
≠ Portable medical electronic devices containing lithium metal batteries exceeding 2 grams but not exceeding 8 grams or lithium ion batteries exceeding 100 Wh but not exceeding 160 Wh	Yes	Yes	Yes	Yes	No	
≠ Spare batteries for portable medical electronic devices containing lithium metal batteries exceeding 2 grams but not exceeding 8 grams or lithium ion batteries exceeding 100 Wh but not exceeding 160 Wh	No	Yes	Yes	Yes	No	
9) Small medical or clinical thermometer which contains mercury	Yes	Yes	Yes	No	No	<ul style="list-style-type: none"> a) no more than one per person; b) must be for personal use; and c) must be in its protective case.

Items or articles	Location			Approval of the operator(s) is required	The pilot-in-command must be informed	Restrictions
	Checked baggage	Carry-on baggage	On the person			
Articles used in dressing or grooming						
10) Toiletry articles (including aerosols)	Yes	Yes	Yes	No	No	<p>a) the term "toiletry articles (including aerosols)" is intended to include such items as hair sprays, perfumes and colognes;</p> <p>b) no more than 0.5 kg or 0.5 L total net quantity per single article;</p> <p>c) release valves on aerosols must be protected by a cap or other suitable means to prevent inadvertent release of the contents; and</p> <p>d) no more than 2 kg or 2 L total net quantity of all articles mentioned in 3), 10) and 13) (e.g. four aerosol cans of 500 mL each) per person.</p>
11) Hair curlers containing hydrocarbon gas	Yes	Yes	Yes	No	No	<p>a) no more than one per person;</p> <p>b) the safety cover must be securely fitted over the heating element; and</p> <p>c) gas refills for such curlers must not be carried.</p>
Consumer articles						
12) Alcoholic beverages containing more than 24 per cent but not more than 70 per cent alcohol by volume	Yes	Yes	Yes	No	No	<p>a) must be in retail packagings;</p> <p>b) no more than 5 L per individual receptacle; and</p> <p>c) no more than 5 L total net quantity per person for such beverages.</p> <p><i>Note. — Alcoholic beverages containing not more than 24 per cent alcohol by volume are not subject to any restrictions.</i></p>
13) Aerosols in Division 2.2, with no subsidiary risk, for sporting or home use	Yes	No	No	No	No	<p>a) no more than 0.5 kg or 0.5 L total net quantity per single article;</p> <p>b) release valves on aerosols must be protected by a cap or other suitable means to prevent inadvertent release of the contents; and</p> <p>c) no more than 2 kg or 2 L total net quantity of all articles mentioned in 3), 10) and 13) (e.g. four aerosol cans of 500 mL each) per person.</p>
14) Securely packaged cartridges in Division 1.4S (UN 0012 or UN 0014 only);	Yes	No	No	Yes	No	<p>a) no more than 5 kg gross mass per person for that person's own use;</p> <p>b) must not include ammunition with explosive or incendiary projectiles; and</p> <p>c) allowances for more than one person must not be combined into one or more packages.</p>
15) Small packet of safety matches	No	No	Yes	No	No	<p>a) no more than one per person; and</p> <p>b) intended for use by an individual.</p>
----- "Strike anywhere" matches -----	No	No	No	n/a	n/a	Forbidden.

<i>Items or articles</i>	<i>Location</i>			<i>Approval of the operator(s) is required</i>	<i>The pilot-in-command must be informed</i>	<i>Restrictions</i>
	<i>Checked baggage</i>	<i>Carry-on baggage</i>	<i>On the person</i>			
Small cigarette lighter	No	No	Yes	No	No	a) no more than one per person; b) intended for use by an individual; and c) does not contain unabsorbed liquid fuel (other than liquefied gas).
Lighter fuel and lighter refills	No	No	No	n/a	n/a	Forbidden.
Premixing burner lighter (see the Glossary of Terms in Attachment 2) with a means of protection against unintentional activation	No	No	Yes	No	No	a) no more than one per person; b) intended for use by an individual; and c) does not contain unabsorbed liquid fuel (other than liquefied gas).
Premixing burner lighter (see the Glossary of Terms in Attachment 2) without a means of protection against unintentional activation	No	No	No	n/a	n/a	Forbidden.
16) Battery-powered equipment capable of generating extreme heat, which could cause a fire if activated (e.g. underwater high intensity lamps)	Yes	Yes	No	Yes	No	a) the heat-producing component and the battery are isolated from each other by the removal of the heat-producing component, the battery or another component (e.g. fuse); and b) any battery which has been removed must be protected against short circuit (by placement in original retail packaging or by otherwise insulating terminals, e.g. by taping over exposed terminals or placing each battery in a separate plastic bag or protective pouch).
≠ 17) Avalanche rescue backpack containing a cylinder of compressed gas of Division 2.2 without subsidiary risk	Yes	Yes	No	Yes	No	a) no more than one per person; b) may contain a pyrotechnic trigger mechanism which must not contain more than 200 mg net of Division 1.4S; c) the backpack must be packed in such a manner that it cannot be accidentally activated; and d) the airbags within the backpack must be fitted with pressure relief valves.
≠ 18) Small cartridges fitted into a self-inflating personal safety device such as a life-jacket or vest	Yes	Yes	Yes	Yes	No	a) no more than one personal safety device per person; b) the personal safety device must be packed in such a manner that it cannot be accidentally activated; c) limited to carbon dioxide or another suitable gas in Division 2.2 without subsidiary risk; d) must be for inflation purposes; e) the device must be fitted with no more than two small cartridges; and f) no more than two spare cartridges.

Items or articles	Location			Approval of the operator(s) is required	The pilot-in-command must be informed	Restrictions
	Checked baggage	Carry-on baggage	On the person			
≠ Small cartridges for other devices	Yes	Yes	Yes	Yes	No	a) no more than four small cartridges of carbon dioxide or other suitable gas in Division 2.2, without subsidiary risk, per person; and b) the water capacity of each cartridge must not exceed 50 mL. <i>Note.— For carbon dioxide, a gas cartridge with a water capacity of 50 mL is equivalent to a 28 g cartridge.</i>
19) Portable electronic devices (such as watches, calculating machines, cameras, cellular phones, laptop computers, camcorders)						
≠ Portable electronic devices (including medical devices) containing lithium metal or lithium ion cells or batteries (articles containing lithium metal or lithium ion cells or batteries the primary purpose of which is to provide power to another device must be carried as spare batteries in accordance with the item below)	Yes	Yes	Yes	No	No	a) carried by passengers or crew for personal use; b) should be carried as carry-on baggage; c) each battery must not exceed the following: — for lithium metal batteries, a lithium content of not more than 2 grams; or — for lithium ion batteries, a Watt-hour rating of not more than 100 Wh; d) if devices are carried in checked baggage, measures must be taken to prevent unintentional activation; and e) batteries and cells must be of a type which meets the requirements of each test in the UN <i>Manual of Tests and Criteria</i> , Part III, subsection 38.3.
Spare batteries for portable electronic devices (including medical devices) containing lithium metal or lithium ion cells or batteries	No	Yes	Yes	No	No	a) carried by passengers or crew for personal use; b) must be individually protected so as to prevent short circuits (by placement in original retail packaging or by otherwise insulating terminals, e.g. by taping over exposed terminals or placing each battery in a separate plastic bag or protective pouch); c) each battery must not exceed the following: — for lithium metal batteries, a lithium content of not more than 2 grams; or — for lithium ion batteries, a Watt-hour rating of not more than 100 Wh; and d) batteries and cells must be of a type which meets the requirements of each test in the UN <i>Manual of Tests and Criteria</i> , Part III, subsection 38.3.

<i>Items or articles</i>	<i>Location</i>			<i>Approval of the operator(s) is required</i>	<i>The pilot-in-command must be informed</i>	<i>Restrictions</i>
	<i>Checked baggage</i>	<i>Carry-on baggage</i>	<i>On the person</i>			
Portable electronic devices containing lithium ion batteries exceeding a Watt-hour rating of 100 Wh but not exceeding 160 Wh	Yes	Yes	Yes	Yes	No	<ul style="list-style-type: none"> a) carried by passengers or crew for personal use; b) should be carried as carry-on baggage; and c) batteries and cells must be of a type which meets the requirements of each test in the UN <i>Manual of Tests and Criteria</i>, Part III, subsection 38.3.
Spare batteries for portable electronic devices containing lithium ion batteries exceeding a Watt-hour rating of 100 Wh but not exceeding 160 Wh	No	Yes	Yes	Yes	No	<ul style="list-style-type: none"> a) carried by passengers or crew for personal use; b) no more than two individually protected spare batteries per person; c) must be individually protected so as to prevent short circuits (by placement in original retail packaging or by otherwise insulating terminals, e.g. by taping over exposed terminals or placing each battery in a separate plastic bag or protective pouch); and d) batteries and cells must be of a type which meets the requirements of each test in the UN <i>Manual of Tests and Criteria</i>, Part III, subsection 38.3.
20) Fuel cells used to power portable electronic devices (for example, cameras, cellular phones, laptop computers and camcorders)	No	Yes	Yes	No	No	<ul style="list-style-type: none"> a) fuel cell cartridges may only contain flammable liquids, corrosive substances, liquefied flammable gas, water reactive substances or hydrogen in metal hydride;
Spare fuel cell cartridges	Yes	Yes	Yes	No	No	<ul style="list-style-type: none"> b) refuelling of fuel cells on board an aircraft is not permitted except that the installation of a spare cartridge is allowed; c) the maximum quantity of fuel in any fuel cell or fuel cell cartridge must not exceed: <ul style="list-style-type: none"> — for liquids 200 mL; — for solids 200 grams; — for liquefied gases, 120 mL for non-metallic fuel cell cartridges or 200 mL for metal fuel cell or fuel cell cartridges; and — for hydrogen in metal hydride, the fuel cell or fuel cell cartridges must have a water capacity of 120 mL or less;

Items or articles	Location			Approval of the operator(s) is required	The pilot-in-command must be informed	Restrictions
	Checked baggage	Carry-on baggage	On the person			
						<p>d) each fuel cell and each fuel cell cartridge must conform to IEC 62282-6-100 Ed. 1, including Amendment 1, and must be marked with a manufacturer's certification that it conforms to the specification. In addition, each fuel cell cartridge must be marked with the maximum quantity and type of fuel in the cartridge;</p> <p>e) fuel cell cartridges containing hydrogen in metal hydride must comply with the requirements in Special Provision A162;</p> <p>f) no more than two spare fuel cell cartridges may be carried by a passenger;</p> <p>g) fuel cells containing fuel are permitted in carry-on baggage only;</p> <p>h) interaction between fuel cells and integrated batteries in a device must conform to IEC 62282-6-100 Ed. 1, including Amendment 1. Fuel cells whose sole function is to charge a battery in the device are not permitted;</p> <p>i) fuel cells must be of a type that will not charge batteries when the portable electronic device is not in use and must be durably marked by the manufacturer: "APPROVED FOR CARRIAGE IN AIRCRAFT CABIN ONLY" to so indicate; and</p> <p>j) in addition to the languages which may be required by the State of Origin for the markings specified above, English should be used.</p>
21) Dry ice	Yes	Yes	No	Yes	No	<p>a) no more than 2.5 kg per person;</p> <p>b) used to pack perishables that are not subject to these Instructions;</p> <p>c) the package must permit the release of carbon dioxide gas; and</p> <p>d) when carried in checked baggage, each package must be marked:</p> <ul style="list-style-type: none"> — "DRY ICE" or "CARBON DIOXIDE, SOLID"; and — the net weight of dry ice or an indication that the net weight is 2.5 kg or less.
22) A mercurial barometer or mercurial thermometer	No	Yes	No	Yes	Yes	<p>a) must be carried by a representative of a government weather bureau or similar official agency; and</p> <p>b) must be packed in a strong outer packaging, having a sealed inner liner or a bag of strong leakproof and puncture-resistant material impervious to mercury, which will prevent the escape of mercury from the package irrespective of its position.</p>

<i>Items or articles</i>	<i>Location</i>			<i>Approval of the operator(s) is required</i>	<i>The pilot-in-command must be informed</i>	<i>Restrictions</i>
	<i>Checked baggage</i>	<i>Carry-on baggage</i>	<i>On the person</i>			
23) Instruments containing radioactive material (i.e. chemical agent monitor (CAM) and/or rapid alarm and identification device monitor (RAID-M))	Yes	Yes	No	Yes	No	a) the instruments must not exceed the activity limits specified in Table 2-14 of these Instructions; b) must be securely packed and without lithium batteries; and c) must be carried by staff members of the Organization for the Prohibition of Chemical Weapons (OPCW) on official travel.
≠ 24) Energy efficient lamps	Yes	Yes	Yes	No	No	a) when in retail packaging; and b) intended for personal or home use.
25) Permeation devices for calibrating air quality monitoring equipment	Yes	No	No	No	No	Must comply with Special Provision A41.
26) Portable electronic equipment containing a non-spillable battery meeting the requirements of Special Provision A67	Yes	Yes	No	No	No	a) the battery must not have a voltage greater than 12 volts and a Watt-hour rating of not greater than 100 Wh; and b) the equipment must be either protected from inadvertent activation, or the battery disconnected and exposed terminals insulated.
Spare non-spillable batteries meeting the requirements of Special Provision A67	Yes	Yes	No	No	No	a) the battery must not have a voltage greater than 12 volts and a Watt-hour rating of not greater than 100 Wh; b) the battery must be protected from short circuit by the effective insulation of exposed terminals; and c) no more than two individually protected batteries per person.
27) Internal combustion engines or fuel cell engines	Yes	No	No	No	No	Must comply with Special Provision A70.
28) Non-infectious specimens	Yes	Yes	No	No	No	Must comply with Special Provision A180.
29) Insulated packagings containing refrigerated liquid nitrogen	Yes	Yes	No	No	No	Must comply with Special Provision A152.

Security-type equipment	Yes	No	No	Yes	No	
30) Security-type equipment, such as attaché cases, cash boxes, cash bags, etc., incorporating dangerous goods as part of this equipment, for example, lithium batteries or pyrotechnic material	Yes	No	No	Yes	No	<p>a) the equipment must be equipped with an effective means of preventing accidental activation;</p> <p>b) if the equipment contains an explosive or pyrotechnic substance or an explosive article, this article or substance must be excluded from Class 1 by the appropriate national authority of the State of Manufacture in compliance with Part 2:1.5.2.1;</p> <p>c) if the equipment contains lithium cells or batteries, these cells or batteries must comply with the following restrictions:</p> <ul style="list-style-type: none"> — for a lithium metal cell, the lithium content is not more than 1 g; — for a lithium metal battery, the aggregate lithium content is not more than 2 g; — for lithium ion cells, the Watt-hour rating (see the Glossary of Terms in Attachment 2) is not more than 20 Wh; — for lithium ion batteries, the Watt-hour rating is not more than 100 Wh; — each cell or battery is of the type proven to meet the requirements of each test in the <i>UN Manual of Tests and Criteria</i>, Part III, subsection 38.3; <p>d) if the equipment contains gases to expel dye or ink:</p> <ul style="list-style-type: none"> — only gas cartridges and receptacles, small, containing gas with a capacity not exceeding 50 mL, containing no constituents subject to these Instructions other than a Division 2.2 gas, are allowed; — the release of gas must not cause extreme annoyance or discomfort to crew members so as to prevent the correct performance of assigned duties; and — in case of accidental activation, all hazardous effects must be confined within the equipment and must not produce extreme noise; and <p>e) security type equipment that is defective or that has been damaged is forbidden for transport.</p>

Attachment 1

LISTS OF PROPER SHIPPING NAMES

Chapter 1

**LIST OF UN NUMBERS
WITH ASSOCIATED PROPER SHIPPING NAMES**

0004	Ammonium picrate dry or wetted with less than 10% water, by mass	0034	Bombs with bursting charge
0005	Cartridges for weapons with bursting charge	0035	Bombs with bursting charge
0006	Cartridges for weapons with bursting charge	0037	Bombs, photo-flash
0007	Cartridges for weapons with bursting charge	0038	Bombs, photo-flash
0009	Ammunition, incendiary with or without burster, expelling charge or propelling charge	0039	Bombs, photo-flash
0010	Ammunition, incendiary with or without burster, expelling charge or propelling charge	0042	Boosters without detonator
0012	Cartridges for weapons, inert projectile <i>or Cartridges, small arms</i>	0043	Bursters , explosive
0014	Cartridges for tools, blank <i>or Cartridges for weapons, blank</i> <i>or Cartridges, small arms, blank</i>	0044	Primers, cap type
0015	Ammunition, smoke with or without burster, expelling charge or propelling charge	0048	Charges, demolition
0016	Ammunition, smoke with or without burster, expelling charge or propelling charge	0049	Cartridges, flash
0018	Ammunition, tear-producing with burster, expelling charge or propelling charge	0050	Cartridges, flash
0019	Ammunition, tear-producing with burster, expelling charge or propelling charge	0054	Cartridges, signal
0020	Ammunition, toxic with burster, expelling charge or propelling charge	0055	Cases, cartridge, empty, with primer
0021	Ammunition, toxic with burster, expelling charge or propelling charge	0056	Charges, depth
0027	Black powder , granular or as a meal <i>or Gunpowder</i> , granular or as a meal	0059	Charges, shaped without detonator
0028	Black powder, compressed <i>or Black powder in pellets</i> <i>or Gunpowder, compressed</i> <i>or Gunpowder in pellets</i>	0060	Charges, supplementary, explosive
0029	Detonators, non-electric for blasting	0065	Cord, detonating , flexible
0030	Detonators, electric for blasting	0066	Cord, igniter
0033	Bombs with bursting charge	0070	Cutters, cable, explosive
		0072	Cyclonite, wetted with not less than 15% water, by mass <i>or Cyclotrimethylenetrinitramine, wetted</i> with not less than 15% water, by mass <i>or Hexogen, wetted</i> with not less than 15% water, by mass <i>or RDX, wetted</i> with not less than 15% water, by mass
		0073	Detonators for ammunition
		0074	Diazodinitrophenol, wetted with not less than 40% water, or mixture of alcohol and water, by mass
		0075	Diethyleneglycol dinitrate, desensitized with not less than 25% non-volatile, water-insoluble phlegmatizer, by mass
		0076	Dinitrophenol , dry or wetted with less than 15% water, by mass
		0077	Dinitrophenolates , alkali metals, dry or wetted with less than 15% water, by mass

0078	Dinitroresorcinol , dry or wetted with less than 15% water, by mass	<i>or Nitromannite, wetted</i> with not less than 40% water, or mixture of alcohol and water, by mass
0079	Dipicrylamine <i>or Hexanitrodiphenylamine</i> <i>or Hexyl</i>	0135 Mercury fulminate, wetted with not less than 20% water, or mixture of alcohol and water, by mass
0081	Explosive, blasting, type A	0136 Mines with bursting charge
0082	Explosive, blasting, type B	0137 Mines with bursting charge
0083	Explosive, blasting, type C	0138 Mines with bursting charge
0084	Explosive, blasting, type D	0143 Nitroglycerin, desensitized with not less than 40% non-volatile water-insoluble phlegmatizer, by mass
0092	Flares, surface	0144 Nitroglycerin solution in alcohol with more than 1% but not more than 10% nitroglycerin
0093	Flares, aerial	0146 Nitrostarch , dry or wetted with less than 20% water, by mass
0094	Flash powder	0147 Nitro urea
0099	Fracturing devices, explosive , without detonator for oil wells	0150 Pentaerythrite tetranitrate, desensitized with not less than 15% phlegmatizer by mass <i>or Pentaerythrite tetranitrate, wetted</i> with not less than 25% water, by mass <i>or Pentaerythritol tetranitrate, desensitized</i> with not less than 15% phlegmatizer, by mass <i>or Pentaerythritol tetranitrate, wetted</i> with not less than 25% water, by mass <i>or PETN, desensitized</i> with not less than 15% phlegmatizer, by mass <i>or PETN, wetted</i> with not less than 25% water, by mass
0101	Fuse, non-detonating	0151 Pentolite , dry or wetted with less than 15% water, by mass
0102	Cord, detonating , metal clad <i>or Fuse, detonating</i> , metal clad	0153 Picramide <i>or Trinitroaniline</i>
0103	Fuse, igniter , tubular, metal clad	0154 Picric acid , dry or wetted with less than 30% water, by mass <i>or Trinitrophenol</i> , dry or wetted with less than 30% water, by mass
0104	Cord, detonating, mild effect , metal clad <i>or Fuse, detonating, mild effect</i> , metal clad	0155 Picryl chloride <i>or Trinitrochlorobenzene</i>
0105	Fuse, safety	0159 Powder cake, wetted with not less than 25% water, by mass <i>or Powder paste, wetted</i> with not less than 25% water, by mass
0106	Fuzes, detonating	0160 Powder, smokeless
0107	Fuzes, detonating	0161 Powder, smokeless
0110	Grenades, practice , hand or rifle	0167 Projectiles with bursting charge
0113	Guanyl nitrosaminoguanylidene hydrazine, wetted with not less than 30% water, by mass	0168 Projectiles with bursting charge
0114	Guanyl nitrosaminoguanyltetrazene, wetted with not less than 30% water, or mixture of alcohol and water, by mass <i>or Tetrazene, wetted</i> with not less than 30% water, or mixture of alcohol and water, by mass	0169 Projectiles with bursting charge
0118	Hexolite , dry or wetted with less than 15% water, by mass <i>or Hexotol</i> , dry or wetted with less than 15% water, by mass	0171 Ammunition, illuminating with or without burster, expelling charge or propelling charge
0121	Igniters	0173 Release devices, explosive
0124	Jet perforating guns, charged , oil well, without detonator	0174 Rivets, explosive
0129	Lead azide, wetted with not less than 20% water, or mixture of alcohol and water, by mass	
0130	Lead styphnate, wetted with not less than 20% water, or mixture of alcohol and water, by mass <i>or Lead trinitroresorcinate, wetted</i> with not less than 20% water, or mixture of alcohol and water, by mass	
0131	Lighters, fuse	
0132	Deflagrating metal salts of aromatic nitro-derivatives, n.o.s.	
0133	Mannitol hexanitrate, wetted with not less than 40% water, or mixture of alcohol and water, by mass	

0180	Rockets with bursting charge	0234	Sodium dinitro-o-cresolate , dry or wetted with less than 15% water, by mass
0181	Rockets with bursting charge	0235	Sodium picramate , dry or wetted with less than 20% water, by mass
0182	Rockets with bursting charge	0236	Zirconium picramate , dry or wetted with less than 20% water, by mass
0183	Rockets with inert head	0237	Charges, shaped, flexible, linear
0186	Rocket motors	0238	Rockets, line-throwing
0190	Samples, explosive , other than initiating explosives	0240	Rockets, line-throwing
0191	Signal devices, hand	0241	Explosive, blasting, type E
0192	Signals, railway track, explosive	0242	Charges, propelling, for cannon
0193	Signals, railway track, explosive	0243	Ammunition, incendiary, white phosphorus with burster, expelling charge or propelling charge
0194	Signals, distress, ship	0244	Ammunition, incendiary, white phosphorus with burster, expelling charge or propelling charge
0195	Signals, distress, ship	0245	Ammunition, smoke, white phosphorus with burster, expelling charge or propelling charge
0196	Signals, smoke	0246	Ammunition, smoke, white phosphorus with burster, expelling charge or propelling charge
0197	Signals, smoke	0247	Ammunition, incendiary , liquid or gel, with burster, expelling charge or propelling charge
0204	Sounding devices, explosive	0248	Contrivances, water-activated with burster, expelling charge or propelling charge
0207	Tetranitroaniline	0249	Contrivances, water-activated with burster, expelling charge or propelling charge
0208	Tetryl <i>or</i> Trinitrophenylmethylnitramine	0250	Rocket motors with hypergolic liquids with or without expelling charge
0209	TNT , dry or wetted with less than 30% water, by mass <i>or</i> Trinitrotoluene , dry or wetted with less than 30% water, by mass	0254	Ammunition, illuminating with or without burster, expelling charge or propelling charge
0212	Tracers for ammunition	0255	Detonators, electric for blasting
0213	Trinitroanisole	0257	Fuzes, detonating
0214	Trinitrobenzene , dry or wetted with less than 30% water, by mass	0266	Octol , dry or wetted with less than 15% water, by mass <i>or</i> Octolite , dry or wetted with less than 15% water, by mass
0215	Trinitrobenzoic acid , dry or wetted with less than 30% water, by mass	0267	Detonators, non-electric for blasting
0216	Trinitro-m-cresol	0268	Boosters with detonator
0217	Trinitronaphthalene	0271	Charges, propelling
0218	Trinitrophenetole	0272	Charges, propelling
0219	Styphnic acid , dry or wetted with less than 20% water, or mixture of alcohol and water, by mass <i>or</i> Trinitroresorcinol , dry or wetted with less than 20% water, or mixture of alcohol and water, by mass	0275	Cartridges, power device
0220	Urea nitrate , dry or wetted with less than 20% water, by mass	0276	Cartridges, power device
0221	Warheads, torpedo with bursting charge	0277	Cartridges, oil well
0222	Ammonium nitrate	0278	Cartridges, oil well
0224	Barium azide , dry or wetted with less than 50% water, by mass	0279	Charges, propelling, for cannon
0225	Boosters with detonator	0280	Rocket motors
0226	Cyclotetramethylenetetranitramine, wetted with not less than 15% water, by mass <i>or</i> HMX, wetted with not less than 15% water, by mass <i>or</i> Octogen, wetted with not less than 15% water, by mass	0281	Rocket motors
		0282	Nitroguanidine , dry or wetted with less than 20% water,

	<i>or Picrite, dry or wetted with less than 20% water, by mass</i>		<i>or Cartridges, small arms, blank</i>
0283	Boosters without detonator	0328	Cartridges for weapons, inert projectile
0284	Grenades, hand or rifle, with bursting charge	0329	Torpedoes with bursting charge
0285	Grenades, hand or rifle, with bursting charge	0330	Torpedoes with bursting charge
0286	Warheads, rocket with bursting charge	0331	Agent, blasting, type B
0287	Warheads, rocket with bursting charge		<i>or Explosive, blasting, type B</i>
0288	Charges, shaped, flexible, linear	0332	Agent, blasting, type E
0289	Cord, detonating, flexible		<i>or Explosive, blasting, type E</i>
0290	Cord, detonating, metal clad	0333	Fireworks
	<i>or Fuse, detonating, metal clad</i>	0334	Fireworks
0291	Bombs with bursting charge	0335	Fireworks
0292	Grenades, hand or rifle, with bursting charge	0336	Fireworks
0293	Grenades, hand or rifle, with bursting charge	0337	Fireworks
0294	Mines with bursting charge	0338	Cartridges for weapons, blank
0295	Rockets with bursting charge		<i>or Cartridges, small arms, blank</i>
0296	Sounding devices, explosive	0339	Cartridges for weapons, inert projectile
0297	Ammunition, illuminating with or without burster, expelling charge or propelling charge		<i>or Cartridges, small arms</i>
0299	Bombs, photo-flash	0340	Nitrocellulose, dry or wetted with less than 25% water (or alcohol), by mass
0300	Ammunition, incendiary with or without burster, expelling charge or propelling charge	0341	Nitrocellulose, unmodified or plasticized with less than 18% plasticizing substance, by mass
0301	Ammunition, tear-producing with burster, expelling charge or propelling charge	0342	Nitrocellulose, wetted with not less than 25% alcohol, by mass
0303	Ammunition, smoke with or without burster, expelling charge or propelling charge	0343	Nitrocellulose, plasticized with not less than 18% plasticizing substance, by mass
0305	Flash powder	0344	Projectiles with bursting charge
0306	Tracers for ammunition	0345	Projectiles, inert with tracer
0312	Cartridges, signal	0346	Projectiles with burster or expelling charge
0313	Signals, smoke	0347	Projectiles with burster or expelling charge
0314	Igniters	0348	Cartridges for weapons with bursting charge
0315	Igniters	0349	Articles, explosive, n.o.s.
0316	Fuzes, igniting	0350	Articles, explosive, n.o.s.
0317	Fuzes, igniting	0351	Articles, explosive, n.o.s.
0318	Grenades, practice, hand or rifle	0352	Articles, explosive, n.o.s.
0319	Primers, tubular	0353	Articles, explosive, n.o.s.
0320	Primers, tubular	0354	Articles, explosive, n.o.s.
0321	Cartridges for weapons with bursting charge	0355	Articles, explosive, n.o.s.
0322	Rocket motors with hypergolic liquids with or without expelling charge	0356	Articles, explosive, n.o.s.
0323	Cartridges, power device	0357	Substances, explosive, n.o.s.
0324	Projectiles with bursting charge	0358	Substances, explosive, n.o.s.
0325	Igniters	0359	Substances, explosive, n.o.s.
0326	Cartridges for weapons, blank	0360	Detonator assemblies, non-electric for blasting
0327	Cartridges for weapons, blank	0361	Detonator assemblies, non-electric for blasting
		0362	Ammunition, practice

0363	Ammunition, proof	<i>or</i> Hexogen and cyclotetramethylenetetranitramine mixture, desensitized with not less than 10% phlegmatizer, by mass
0364	Detonators for ammunition	
0365	Detonators for ammunition	<i>or</i> Hexogen and cyclotetramethylenetetranitramine mixture, wetted with not less than 15% water, by mass
0366	Detonators for ammunition	
0367	Fuzes, detonating	<i>or</i> RDX and cyclotetramethylenetetranitramine mixture, desensitized with not less than 10% phlegmatizer, by mass
0368	Fuzes, igniting	
0369	Warheads, rocket with bursting charge	<i>or</i> RDX and cyclotetramethylenetetranitramine mixture, wetted with not less than 15% water, by mass
0370	Warheads, rocket with burster or expelling charge	
0371	Warheads, rocket with burster or expelling charge	0392 Hexanitrostilbene
0372	Grenades, practice, hand or rifle	0393 Hexotonal
0373	Signal devices, hand	0394 Styphnic acid, wetted with not less than 20% water, or mixture of alcohol and water, by mass
0374	Sounding devices, explosive	<i>or</i> Trinitroresorcinol, wetted with not less than 20% water, or mixture of alcohol and water, by mass
0375	Sounding devices, explosive	
0376	Primers, tubular	0395 Rocket motors, liquid fuelled
0377	Primers, cap type	0396 Rocket motors, liquid fuelled
0378	Primers, cap type	0397 Rockets, liquid fuelled with bursting charge
0379	Cases, cartridge, empty, with primer	0398 Rockets, liquid fuelled with bursting charge
0380	Articles, pyrophoric	0399 Bombs with flammable liquid with bursting charge
0381	Cartridges, power device	0400 Bombs with flammable liquid with bursting charge
0382	Components, explosive train, n.o.s.	0401 Dipicryl sulphide, dry or wetted with less than 10% water, by mass
0383	Components, explosive train, n.o.s.	0402 Ammonium perchlorate
0384	Components, explosive train, n.o.s.	0403 Flares, aerial
0385	5-Nitrobenzotriazol	0404 Flares, aerial
0386	Trinitrobenzenesulphonic acid	0405 Cartridges, signal
0387	Trinitrofluorenone	0406 Dinitrosobenzene
0388	TNT and hexanitrostilbene mixture <i>or</i> TNT and trinitrobenzene mixture <i>or</i> Trinitrotoluene and hexanitrostilbene mixture <i>or</i> Trinitrotoluene and trinitrobenzene mixture	0407 Tetrazol-1-acetic acid
0389	TNT mixture containing trinitrobenzene and hexanitrostilbene <i>or</i> Trinitrotoluene mixture containing trinitrobenzene and hexanitrostilbene	0408 Fuzes, detonating with protective features
0390	Tritonal	0409 Fuzes, detonating with protective features
0391	Cyclonite and cyclotetramethylenetetranitramine mixture, desensitized with not less than 10% phlegmatizer, by mass <i>or</i> Cyclonite and cyclotetramethylenetetranitramine mixture, wetted with not less than 15% water, by mass <i>or</i> Cyclotrimethylenetrinitramine and cyclotetramethylenetetranitramine mixture, desensitized with not less than 10% phlegmatizer, by mass <i>or</i> Cyclotrimethylenetrinitramine and cyclotetramethylenetetranitramine mixture, wetted with not less than 15% water, by mass	0410 Fuzes, detonating with protective features
		0411 Pentaerythrite tetranitrate with not less than 7% wax, by mass <i>or</i> Pentaerythritol tetranitrate with not less than 7% wax, by mass <i>or</i> PETN with not less than 7% wax, by mass
		0412 Cartridges for weapons with bursting charge
		0413 Cartridges for weapons, blank
		0414 Charges, propelling, for cannon
		0415 Charges, propelling
		0417 Cartridges for weapons, inert projectile <i>or</i> Cartridges, small arms
		0418 Flares, surface
		0419 Flares, surface

0420	Flares, aerial	0462	Articles, explosive, n.o.s.
0421	Flares, aerial	0463	Articles, explosive, n.o.s.
0424	Projectiles, inert with tracer	0464	Articles, explosive, n.o.s.
0425	Projectiles, inert with tracer	0465	Articles, explosive, n.o.s.
0426	Projectiles with burster or expelling charge	0466	Articles, explosive, n.o.s.
0427	Projectiles with burster or expelling charge	0467	Articles, explosive, n.o.s.
0428	Articles, pyrotechnic for technical purposes	0468	Articles, explosive, n.o.s.
0429	Articles, pyrotechnic for technical purposes	0469	Articles, explosive, n.o.s.
0430	Articles, pyrotechnic for technical purposes	0470	Articles, explosive, n.o.s.
0431	Articles, pyrotechnic for technical purposes	0471	Articles, explosive, n.o.s.
0432	Articles, pyrotechnic for technical purposes	0472	Articles, explosive, n.o.s.
0433	Powder cake, wetted with not less than 17% alcohol, by mass <i>or Powder paste, wetted</i> with not less than 17% alcohol, by mass	0473	Substances, explosive, n.o.s.
0434	Projectiles with burster or expelling charge	0474	Substances, explosive, n.o.s.
0435	Projectiles with burster or expelling charge	0475	Substances, explosive, n.o.s.
0436	Rockets with expelling charge	0476	Substances, explosive, n.o.s.
0437	Rockets with expelling charge	0477	Substances, explosive, n.o.s.
0438	Rockets with expelling charge	0478	Substances, explosive, n.o.s.
0439	Charges, shaped without detonator	0479	Substances, explosive, n.o.s.
0440	Charges, shaped without detonator	0480	Substances, explosive, n.o.s.
0441	Charges, shaped without detonator	0481	Substances, explosive, n.o.s.
0442	Charges, explosive, commercial without detonator	0482	Substances, EVI, n.o.s. <i>or Substances, explosive, very insensitive, n.o.s.</i>
0443	Charges, explosive, commercial without detonator	0483	Cyclonite, desensitized <i>or Cyclotrimethylenetrinitramine, desensitized</i> <i>or Hexogen, desensitized</i> <i>or RDX, desensitized</i>
0444	Charges, explosive, commercial without detonator	0484	Cyclotetramethylene-tetranitramine, desensitized <i>or HMX, desensitized</i> <i>or Octogen, desensitized</i>
0445	Charges, explosive, commercial without detonator	0485	Substances, explosive, n.o.s.
0446	Cases, combustible, empty, without primer	0486	Articles, EEI <i>or Articles, explosive, extremely insensitive</i>
0447	Cases, combustible, empty, without primer	0487	Signals, smoke
0448	5-Mercaptotetrazol-1-acetic acid	0488	Ammunition, practice
0449	Torpedoes, liquid fuelled with or without bursting charge	0489	DINGU <i>or Dinitroglycoluril</i>
0450	Torpedoes, liquid fuelled with inert head	0490	Nitrotriazolone <i>or NTO</i>
0451	Torpedoes with bursting charge	0491	Charges, propelling
0452	Grenades, practice, hand or rifle	0492	Signals, railway track, explosive
0453	Rockets, line-throwing	0493	Signals, railway track, explosive
0454	Igniters	0494	Jet perforating guns, charged, oil well, without detonator
0455	Detonators, non-electric for blasting	0495	Propellant, liquid
0456	Detonators, electric for blasting		
0457	Charges, bursting, plastics bonded		
0458	Charges, bursting, plastics bonded		
0459	Charges, bursting, plastics bonded		
0460	Charges, bursting, plastics bonded		
0461	Components, explosive train, n.o.s.		

0496	Octonal		<i>or</i> Refrigerant gas R 12
0497	Propellant, liquid	1029	Dichlorofluoromethane
0498	Propellant, solid		<i>or</i> Refrigerant gas R 21
0499	Propellant, solid	1030	1,1-Difluoroethane
0500	Detonator assemblies, non-electric for blasting		<i>or</i> Refrigerant gas R 152a
0501	Propellant, solid	1032	Dimethylamine, anhydrous
0502	Rockets with inert head	1033	Dimethyl ether
0503	Safety devices, pyrotechnic	1035	Ethane
0504	1H-Tetrazole	1036	Ethylamine
0505	Signals, distress, ship	1037	Ethyl chloride
0506	Signals, distress, ship	1038	Ethylene, refrigerated liquid
0507	Signals, smoke	1039	Ethyl methyl ether
0508	1-Hydroxybenzotriazole, anhydrous, dry or wetted with less than 20% water, by mass	1040	Ethylene oxide
0509	Powder, smokeless		<i>or</i> Ethylene oxide with nitrogen up to a total pressure of 1 MPa at 50°C
1001	Acetylene, dissolved	1041	Ethylene oxide and carbon dioxide mixture with more than 9% but not more than 87% ethylene oxide
1002	Air, compressed	1043	Fertilizer ammoniating solution with free ammonia
1003	Air, refrigerated liquid	1044	Fire extinguishers with compressed or liquefied gas
1005	Ammonia, anhydrous	1045	Fluorine, compressed
1006	Argon, compressed	1046	Helium, compressed
1008	Boron trifluoride	1048	Hydrogen bromide, anhydrous
1009	Bromotrifluoromethane <i>or</i> Refrigerant gas R 13B1	1049	Hydrogen, compressed
1010	Butadienes and hydrocarbon mixture, stabilized, containing more than 40% butadienes <i>or</i> Butadienes, stabilized	1050	Hydrogen chloride, anhydrous
1011	Butane	1051	Hydrogen cyanide, stabilized containing less than 3% water
1012	Butylene	1052	Hydrogen fluoride, anhydrous
1013	Carbon dioxide	1053	Hydrogen sulphide
1016	Carbon monoxide, compressed	1055	Isobutylene
1017	Chlorine	1056	Krypton, compressed
1018	Chlorodifluoromethane <i>or</i> Refrigerant gas R 22	1057	Lighter refills containing flammable gas <i>or</i> Lighters containing flammable gas
1020	Chloropentafluoroethane <i>or</i> Refrigerant gas R 115	1058	Liquefied gases, non-flammable, charged with nitrogen, carbon dioxide or air
1021	1-Chloro-1,2,2,2-tetrafluoroethane <i>or</i> Refrigerant gas R 124	1060	Methylacetylene and propadiene mixture, stabilized
1022	Chlorotrifluoromethane <i>or</i> Refrigerant gas R 13	1061	Methylamine, anhydrous
1023	Coal gas, compressed	1062	Methyl bromide with not more than 2% chloropicrin
1026	Cyanogen	1063	Methyl chloride <i>or</i> Refrigerant gas R 40
1027	Cyclopropane	1064	Methyl mercaptan
1028	Dichlorodifluoromethane	1065	Neon, compressed
		1066	Nitrogen, compressed
		1067	Dinitrogen tetroxide <i>or</i> Nitrogen dioxide

1069	Nitrosyl chloride	1127	Chlorobutanes
1070	Nitrous oxide	1128	n-Butyl formate
1071	Oil gas, compressed	1129	Butyraldehyde
1072	Oxygen, compressed	1130	Camphor oil
1073	Oxygen, refrigerated liquid	1131	Carbon disulphide
1075	Petroleum gases, liquefied	1133	Adhesives containing flammable liquid
1076	Phosgene	1134	Chlorobenzene
1077	Propylene	1135	Ethylene chlorohydrin
1078	Refrigerant gas, n.o.s.	1136	Coal tar distillates, flammable
1079	Sulphur dioxide	1139	Coating solution (includes surface treatments or coatings used for industrial or other purposes such as vehicle undercoating, drum or barrel lining)
1080	Sulphur hexafluoride		
1081	Tetrafluoroethylene, stabilized	1143	Crotonaldehyde
1082	Refrigerant gas R 1113 <i>or</i> Trifluorochloroethylene, stabilized		<i>or</i> Crotonaldehyde, stabilized
1083	Trimethylamine, anhydrous	1144	Crotonylene
1085	Vinyl bromide, stabilized	1145	Cyclohexane
1086	Vinyl chloride, stabilized	1146	Cyclopentane
1087	Vinyl methyl ether, stabilized	1147	Decahydronaphthalene
1088	Acetal	1148	Diacetone alcohol
1089	Acetaldehyde	1149	Dibutyl ethers
1090	Acetone	1150	1,2-Dichloroethylene
1091	Acetone oils	1152	Dichloropentanes
1092	Acrolein, stabilized	1153	Ethylene glycol diethyl ether
1093	Acrylonitrile, stabilized	1154	Diethylamine
1098	Allyl alcohol	1155	Diethyl ether
1099	Allyl bromide		<i>or</i> Ethyl ether
1100	Allyl chloride	1156	Diethyl ketone
1104	Amyl acetates	1157	Diisobutyl ketone
1105	Pentanols	1158	Diisopropylamine
1106	Amylamine	1159	Diisopropyl ether
1107	Amyl chloride	1160	Dimethylamine, aqueous solution
1108	n-Amylene <i>or</i> 1-Pentene	1161	Dimethyl carbonate
1109	Amyl formates	1162	Dimethyldichlorosilane
1110	n-Amyl methyl ketone	1163	Dimethylhydrazine, unsymmetrical
1111	Amyl mercaptan	1164	Dimethyl sulphide
1112	Amyl nitrate	1165	Dioxane
1113	Amyl nitrite	1166	Dioxolane
1114	Benzene	1167	Divinyl ether, stabilized
1120	Butanols	1169	Extracts, aromatic, liquid
1123	Butyl acetates	1170	Ethanol
1125	n-Butylamine		<i>or</i> Ethanol solution
1126	1-Bromobutane		<i>or</i> Ethyl alcohol
			<i>or</i> Ethyl alcohol solution

1171	Ethylene glycol monoethyl ether		<i>or</i> Isobutyl alcohol
1172	Ethylene glycol monoethyl ether acetate	1213	Isobutyl acetate
1173	Ethyl acetate	1214	Isobutylamine
1175	Ethylbenzene	1216	Isooctene
1176	Ethyl borate	1218	Isoprene, stabilized
1177	2-Ethylbutyl acetate	1219	Isopropanol
1178	2-Ethylbutyraldehyde		<i>or</i> Isopropyl alcohol
1179	Ethyl butyl ether	1220	Isopropyl acetate
1180	Ethyl butyrate	1221	Isopropylamine
1181	Ethyl chloroacetate	1222	Isopropyl nitrate
1182	Ethyl chloroformate	1223	Kerosene
1183	Ethyldichlorosilane	1224	Ketones, liquid, n.o.s.
1184	Ethylene dichloride	1228	Mercaptan mixture, liquid, flammable, toxic, n.o.s.
1185	Ethyleneimine, stabilized		<i>or</i> Mercaptans, liquid, flammable, toxic, n.o.s.
1188	Ethylene glycol monomethyl ether	1229	Mesityl oxide
1189	Ethylene glycol monomethyl ether acetate	1230	Methanol
1190	Ethyl formate	1231	Methyl acetate
1191	Octyl aldehydes	1233	Methylamyl acetate
1192	Ethyl lactate	1234	Methylal
1193	Ethyl methyl ketone	1235	Methylamine, aqueous solution
	<i>or</i> Methyl ethyl ketone	1237	Methyl butyrate
1194	Ethyl nitrite solution	1238	Methyl chloroformate
1195	Ethyl propionate	1239	Methyl chloromethyl ether
1196	Ethyltrichlorosilane	1242	Methyldichlorosilane
1197	Extracts, flavouring, liquid	1243	Methyl formate
1198	Formaldehyde solution, flammable	1244	Methylhydrazine
1199	Furaldehydes	1245	Methyl isobutyl ketone
1201	Fusel oil	1246	Methyl isopropenyl ketone, stabilized
1202	Diesel fuel	1247	Methyl methacrylate monomer, stabilized
	<i>or</i> Gas oil	1248	Methyl propionate
	<i>or</i> Heating oil, light	1249	Methyl propyl ketone
1203	Gasoline	1250	Methyltrichlorosilane
	<i>or</i> Motor spirit	1251	Methyl vinyl ketone, stabilized
	<i>or</i> Petrol	1259	Nickel carbonyl
1204	Nitroglycerin solution in alcohol with not more than 1% nitroglycerin	1261	Nitromethane
1206	Heptanes	1262	Octanes
1207	Hexaldehyde	1263	Paint (including paint, lacquer, enamel, stain, shellac, varnish, polish, liquid filler and liquid lacquer base)
1208	Hexanes		<i>or</i> Paint related material (including paint thinning or reducing compound)
1210	Printing ink, flammable	1264	Paraldehyde
	<i>or</i> Printing ink related material (including printing ink thinning or reducing compound), flammable	1265	Pentanes, liquid
1212	Isobutanol	1266	Perfumery products with flammable solvents

1267	Petroleum crude oil	1318	Cobalt resinate, precipitated
1268	Petroleum distillates, n.o.s. <i>or Petroleum products, n.o.s.</i>	1320	Dinitrophenol, wetted with not less than 15% water, by mass
1272	Pine oil	1321	Dinitrophenolates, wetted with not less than 15% water, by mass
1274	n-Propanol <i>or Propyl alcohol, normal</i>	1322	Dinitroresorcinol, wetted with not less than 15% water, by mass
1275	Propionaldehyde	1323	Ferrocium
1276	n-Propyl acetate	1324	Films, nitrocellulose base , gelatin coated, except scrap
1277	Propylamine	1325	Flammable solid, organic, n.o.s.
1278	1-Chloropropane	1326	Hafnium powder, wetted with not less than 25% water (a visible excess of water must be present) (a) mechanically produced, particle size less than 53 microns; (b) chemically produced, particle size less than 840 microns
1279	1,2-Dichloropropane	1327	Bhusa <i>or Hay</i> <i>or Straw</i>
1280	Propylene oxide	1328	Hexamethylenetetramine
1281	Propyl formates	1330	Manganese resinate
1282	Pyridine	1331	Matches, 'strike anywhere'
1286	Rosin oil	1332	Metaldehyde
1287	Rubber solution	1333	Cerium, slabs, ingots or rods
1288	Shale oil	1334	Naphthalene, crude <i>or Naphthalene, refined</i>
1289	Sodium methylate solution in alcohol	1336	Nitroguanidine, wetted with not less than 20% water, by mass <i>or Picrite, wetted</i> with not less than 20% water by mass
1292	Tetraethyl silicate	1337	Nitrostarch, wetted with not less than 20% water, by mass
1293	Tinctures, medicinal	1338	Phosphorus, amorphous
1294	Toluene	1339	Phosphorus heptasulphide , free from yellow and white phosphorus
1295	Trichlorosilane	1340	Phosphorus pentasulphide , free from yellow and white phosphorus
1296	Triethylamine	1341	Phosphorus sesquisulphide , free from yellow and white phosphorus
1297	Trimethylamine, aqueous solution , not more than 50% trimethylamine, by mass	1343	Phosphorus trisulphide , free from yellow and white phosphorus
1298	Trimethylchlorosilane	1344	Picric acid, wetted with not less than 30% water, by mass <i>or Trinitrophenol, wetted</i> with not less than 30% water, by mass
1299	Turpentine	1345	Rubber scrap , powdered or granulated, not exceeding 840 microns and rubber content exceeding 45% <i>or Rubber shoddy</i> , powdered or granulated, not exceeding 840 microns and rubber content exceeding 45%
1300	Turpentine substitute	1346	Silicon powder, amorphous
1301	Vinyl acetate, stabilized	1347	Silver picrate, wetted with not less than 30% water, by mass
1302	Vinyl ethyl ether, stabilized		
1303	Vinylidene chloride, stabilized		
1304	Vinyl isobutyl ether, stabilized		
1305	Vinyltrichlorosilane		
1306	Wood preservatives, liquid		
1307	Xylenes		
1308	Zirconium suspended in a flammable liquid		
1309	Aluminium powder, coated		
1310	Ammonium picrate, wetted with not less than 10% water, by mass		
1312	Borneol		
1313	Calcium resinate		
1314	Calcium resinate, fused		

- 1348 **Sodium dinitro-o-cresolate, wetted** with not less than 15% water, by mass
- 1349 **Sodium picramate, wetted** with not less than 20% water, by mass
- 1350 **Sulphur**
- 1352 **Titanium powder, wetted** with not less than 25% water (a visible excess of water must be present) (a) mechanically produced, particle size less than 53 microns; (b) chemically produced, particle size less than 840 microns
- 1353 **Fabrics impregnated with weakly nitrated nitrocellulose, n.o.s.**
or **Fibres impregnated with weakly nitrated nitrocellulose, n.o.s.**
- 1354 **Trinitrobenzene, wetted** with not less than 30% water, by mass
- 1355 **Trinitrobenzoic acid, wetted** with not less than 30% water, by mass
- 1356 **TNT, wetted** with not less than 30% water, by mass
or **Trinitrotoluene, wetted** with not less than 30% water, by mass
- 1357 **Urea nitrate, wetted** with not less than 20% water, by mass
- 1358 **Zirconium powder, wetted** with not less than 25% water (a visible excess of water must be present) (a) mechanically produced, particle size less than 53 microns; (b) chemically produced, particle size less than 840 microns
- 1360 **Calcium phosphide**
- 1361 **Carbon, animal or vegetable origin**
- 1362 **Carbon, activated**
- 1363 **Copra**
- 1364 **Cotton waste, oily**
- 1365 **Cotton, wet**
- 1369 **p-Nitrosodimethylaniline**
- 1372 **Fibres, animal burnt, wet or damp**
or **Fibres, vegetable burnt, wet or damp**
- 1373 **Fabrics, animal, n.o.s., with oil**
or **Fabrics, synthetic, n.o.s., with oil**
or **Fabrics, vegetable, n.o.s., with oil**
or **Fibres, animal, n.o.s., with oil**
or **Fibres, synthetic, n.o.s., with oil**
or **Fibres, vegetable, n.o.s., with oil**
- 1374 **Fish meal, unstabilized**
or **Fish scrap, unstabilized**
- 1376 **Iron oxide, spent** (obtained from coal gas purification)
or **Iron sponge, spent** (obtained from coal gas)
- 1378 **Metal catalyst, wetted** with a visible excess of liquid
- 1379 **Paper, unsaturated oil treated, incompletely dried** (including carbon paper)
- 1380 **Pentaborane**
- 1381 **Phosphorus, white, dry**
or **Phosphorus, white, in solution**
or **Phosphorus, white, under water**
or **Phosphorus, yellow, dry**
or **Phosphorus, yellow, in solution**
or **Phosphorus, yellow, under water**
- 1382 **Potassium sulphide** with less than 30% water of crystallization
or **Potassium sulphide, anhydrous**
- 1383 **Pyrophoric alloy, n.o.s.**
or **Pyrophoric metal, n.o.s.**
- 1384 **Sodium dithionite**
or **Sodium hydrosulphite**
- 1385 **Sodium sulphide** with less than 30% water of crystallization
or **Sodium sulphide, anhydrous**
- 1386 **Seed cake** with more than 1.5% oil and not more than 11% moisture
- 1387 **Wool waste, wet**
- 1389 **Alkali metal amalgam, liquid**
- 1390 **Alkali metal amides**
- 1391 **Alkali metal dispersion**
or **Alkaline earth metal dispersion**
- 1392 **Alkaline earth metal amalgam, liquid**
- 1393 **Alkaline earth metal alloy, n.o.s.**
- 1394 **Aluminium carbide**
- 1395 **Aluminium ferrosilicon powder**
- 1396 **Aluminium powder, uncoated**
- 1397 **Aluminium phosphide**
- 1398 **Aluminium silicon powder, uncoated**
- 1400 **Barium**
- 1401 **Calcium**
- 1402 **Calcium carbide**
- 1403 **Calcium cyanamide** with more than 0.1% of calcium carbide
- 1404 **Calcium hydride**
- 1405 **Calcium silicide**
- 1407 **Caesium**
- 1408 **Ferrosilicon** with 30% or more but less than 90% silicon
- 1409 **Metal hydrides, water-reactive, n.o.s.**
- 1410 **Lithium aluminium hydride**

1411	Lithium aluminium hydride, ethereal	1463	Chromium trioxide, anhydrous
1413	Lithium borohydride	1465	Didymium nitrate
1414	Lithium hydride	1466	Ferric nitrate
1415	Lithium	1467	Guanidine nitrate
1417	Lithium silicon	1469	Lead nitrate
1418	Magnesium alloys powder <i>or Magnesium powder</i>	1470	Lead perchlorate, solid
1419	Magnesium aluminium phosphide	1471	Lithium hypochlorite, dry <i>or Lithium hypochlorite mixture</i>
1420	Potassium metal alloys, liquid	1472	Lithium peroxide
1421	Alkali metal alloy, liquid, n.o.s.	1473	Magnesium bromate
1422	Potassium sodium alloys, liquid	1474	Magnesium nitrate
1423	Rubidium	1475	Magnesium perchlorate
1426	Sodium borohydride	1476	Magnesium peroxide
1427	Sodium hydride	1477	Nitrates, inorganic, n.o.s.
1428	Sodium	1479	Oxidizing solid, n.o.s.
1431	Sodium methylate	1481	Perchlorates, inorganic, n.o.s.
1432	Sodium phosphide	1482	Permanganates, inorganic, n.o.s.
1433	Stannic phosphides	1483	Peroxides, inorganic, n.o.s.
1435	Zinc ashes	1484	Potassium bromate
1436	Zinc dust <i>or Zinc powder</i>	1485	Potassium chlorate
1437	Zirconium hydride	1486	Potassium nitrate
1438	Aluminium nitrate	1487	Potassium nitrate and sodium nitrite mixture
1439	Ammonium dichromate	1488	Potassium nitrite
1442	Ammonium perchlorate	1489	Potassium perchlorate
1444	Ammonium persulphate	1490	Potassium permanganate
1445	Barium chlorate, solid	1491	Potassium peroxide
1446	Barium nitrate	1492	Potassium persulphate
1447	Barium perchlorate, solid	1493	Silver nitrate
1448	Barium permanganate	1494	Sodium bromate
1449	Barium peroxide	1495	Sodium chlorate
1450	Bromates, inorganic, n.o.s.	1496	Sodium chlorite
1451	Caesium nitrate	1498	Sodium nitrate
1452	Calcium chlorate	1499	Sodium nitrate and potassium nitrate mixture
1453	Calcium chlorite	1500	Sodium nitrite
1454	Calcium nitrate	1502	Sodium perchlorate
1455	Calcium perchlorate	1503	Sodium permanganate
1456	Calcium permanganate	1504	Sodium peroxide
1457	Calcium peroxide	1505	Sodium persulphate
1458	Chlorate and borate mixture	1506	Strontium chlorate
1459	Chlorate and magnesium chloride mixture, solid	1507	Strontium nitrate
1461	Chlorates, inorganic, n.o.s.	1508	Strontium perchlorate
1462	Chlorites, inorganic, n.o.s.	1509	Strontium peroxide
		1510	Tetranitromethane

1511	Urea hydrogen peroxide	1578	Chloronitrobenzenes, solid
1512	Zinc ammonium nitrite	1579	4-Chloro-o-toluidine hydrochloride, solid
1513	Zinc chlorate	1580	Chloropicrin
1514	Zinc nitrate	1581	Chloropicrin and methyl bromide mixture with more than 2% chloropicrin
1515	Zinc permanganate	1582	Chloropicrin and methyl chloride mixture
1516	Zinc peroxide	1583	Chloropicrin mixture, n.o.s.
1517	Zirconium picramate, wetted with not less than 20% water, by mass	1585	Copper acetoarsenite
1541	Acetone cyanohydrin, stabilized	1586	Copper arsenite
1544	Alkaloid salts, solid, n.o.s. <i>or Alkaloids, solid, n.o.s.</i>	1587	Copper cyanide
1545	Allyl isothiocyanate, stabilized	1588	Cyanides, inorganic, solid, n.o.s.
1546	Ammonium arsenate	1589	Cyanogen chloride, stabilized
1547	Aniline	1590	Dichloroanilines, liquid
1548	Aniline hydrochloride	1591	o-Dichlorobenzene
1549	Antimony compound, inorganic, solid, n.o.s.	1593	Dichloromethane
1550	Antimony lactate	1594	Diethyl sulphate
1551	Antimony potassium tartrate	1595	Dimethyl sulphate
1553	Arsenic acid, liquid	1596	Dinitroanilines
1554	Arsenic acid, solid	1597	Dinitrobenzenes, liquid
1555	Arsenic bromide	1598	Dinitro-o-cresol
1556	Arsenic compound, liquid, n.o.s. , inorganic, including: Arsenates, n.o.s.; Arsenites, n.o.s.; and Arsenic sulphides	1599	Dinitrophenol solution
1557	Arsenic compound, solid, n.o.s. , inorganic, including: Arsenates, n.o.s.; Arsenites, n.o.s.; and Arsenic sulphides	1600	Dinitrotoluenes, molten
1558	Arsenic	1601	Disinfectant, solid, toxic, n.o.s.
1559	Arsenic pentoxide	1602	Dye intermediate, liquid, toxic, n.o.s. <i>or Dye, liquid, toxic, n.o.s.</i>
1560	Arsenic trichloride	1603	Ethyl bromoacetate
1561	Arsenic trioxide	1604	Ethylenediamine
1562	Arsenical dust	1605	Ethylene dibromide
1564	Barium compound, n.o.s.	1606	Ferric arsenate
1565	Barium cyanide	1607	Ferric arsenite
1566	Beryllium compound, n.o.s.	1608	Ferrous arsenate
1567	Beryllium powder	1611	Hexaethyl tetraphosphate
1569	Bromoacetone	1612	Hexaethyl tetraphosphate and compressed gas mixture
1570	Brucine	1613	Hydrocyanic acid, aqueous solution with not more than 20% hydrogen cyanide <i>or Hydrogen cyanide, aqueous solution</i> with not more than 20% hydrogen cyanide
1571	Barium azide, wetted with not less than 50% water, by mass	1614	Hydrogen cyanide, stabilized containing less than 3% water and absorbed in a porous inert material
1572	Cacodylic acid	1616	Lead acetate
1573	Calcium arsenate	1617	Lead arsenates
1574	Calcium arsenate and calcium arsenite mixture, solid	1618	Lead arsenites
1575	Calcium cyanide	1620	Lead cyanide
1577	Chlorodinitrobenzenes, liquid	1621	London Purple

1622	Magnesium arsenate	1670	Perchloromethyl mercaptan
1623	Mercuric arsenate	1671	Phenol, solid
1624	Mercuric chloride	1672	Phenylcarbylamine chloride
1625	Mercuric nitrate	1673	Phenylenediamines (o-,m-,p-)
1626	Mercuric potassium cyanide	1674	Phenylmercuric acetate
1627	Mercurous nitrate	1677	Potassium arsenate
1629	Mercury acetate	1678	Potassium arsenite
1630	Mercury ammonium chloride	1679	Potassium cuprocyanide
1631	Mercury benzoate	1680	Potassium cyanide, solid
1634	Mercury bromides	1683	Silver arsenite
1636	Mercury cyanide	1684	Silver cyanide
1637	Mercury gluconate	1685	Sodium arsenate
1638	Mercury iodide	1686	Sodium arsenite, aqueous solution
1639	Mercury nucleate	1687	Sodium azide
1640	Mercury oleate	1688	Sodium cacodylate
1641	Mercury oxide	1689	Sodium cyanide, solid
1642	Mercury oxycyanide, desensitized	1690	Sodium fluoride, solid
1643	Mercury potassium iodide	1691	Strontium arsenite
1644	Mercury salicylate	1692	Strychnine <i>or</i> Strychnine salts
1645	Mercury sulphate	1693	Tear gas substance, liquid, n.o.s.
1646	Mercury thiocyanate	1694	Bromobenzyl cyanides, liquid
1647	Methyl bromide and ethylene dibromide mixture, liquid	1695	Chloroacetone, stabilized
1648	Acetonitrile	1697	Chloroacetophenone, solid
1649	Motor fuel anti-knock mixture	1698	Diphenylamine chloroarsine
1650	beta-Naphthylamine, solid	1699	Diphenylchloroarsine, liquid
1651	Naphthylthiourea	1700	Tear gas candles
1652	Naphthylurea	1701	Xylyl bromide, liquid
1653	Nickel cyanide	1702	1,1,2,2-Tetrachloroethane
1654	Nicotine	1704	Tetraethyl dithiopyrophosphate
1655	Nicotine compound, solid, n.o.s. <i>or</i> Nicotine preparation, solid, n.o.s.	1707	Thallium compound, n.o.s.
1656	Nicotine hydrochloride, liquid <i>or</i> Nicotine hydrochloride solution	1708	Toluidines, liquid
1657	Nicotine salicylate	1709	2,4-Toluylenediamine, solid
1658	Nicotine sulphate solution	1710	Trichloroethylene
1659	Nicotine tartrate	1711	Xylidines, liquid
1660	Nitric oxide, compressed	1712	Zinc arsenate <i>or</i> Zinc arsenate and zinc arsenite mixture <i>or</i> Zinc arsenite
1661	Nitroanilines (o-,m-,p-)	1713	Zinc cyanide
1662	Nitrobenzene	1714	Zinc phosphide
1663	Nitrophenols (o-,m-,p-)	1715	Acetic anhydride
1664	Nitrotoluenes, liquid	1716	Acetyl bromide
1665	Nitroxylens, liquid	1717	Acetyl chloride
1669	Pentachloroethane		

1718	Butyl acid phosphate	1762	Cyclohexenyltrichlorosilane
1719	Caustic alkali liquid, n.o.s.	1763	Cyclohexyltrichlorosilane
1722	Allyl chloroformate	1764	Dichloroacetic acid
1723	Allyl iodide	1765	Dichloroacetyl chloride
1724	Allyltrichlorosilane, stabilized	1766	Dichlorophenyltrichlorosilane
1725	Aluminium bromide, anhydrous	1767	Diethyldichlorosilane
1726	Aluminium chloride, anhydrous	1768	Difluorophosphoric acid, anhydrous
1727	Ammonium hydrogendifluoride, solid	1769	Diphenyldichlorosilane
1728	Amyltrichlorosilane	1770	Diphenylmethyl bromide
1729	Anisoyl chloride	1771	Dodecyltrichlorosilane
1730	Antimony pentachloride, liquid	1773	Ferric chloride, anhydrous
1731	Antimony pentachloride solution	1774	Fire extinguisher charges, corrosive liquid
1732	Antimony pentafluoride	1775	Fluoroboric acid
1733	Antimony trichloride	1776	Fluorophosphoric acid, anhydrous
1736	Benzoyl chloride	1777	Fluorosulphonic acid
1737	Benzyl bromide	1778	Fluorosilicic acid
1738	Benzyl chloride	1779	Formic acid with more than 85% acid by mass
1739	Benzyl chloroformate	1780	Fumaryl chloride
1740	Hydrogendifluorides, solid, n.o.s.	1781	Hexadecyltrichlorosilane
1741	Boron trichloride	1782	Hexafluorophosphoric acid
1742	Boron trifluoride acetic acid complex, liquid	1783	Hexamethylenediamine solution
1743	Boron trifluoride propionic acid complex, liquid	1784	Hexyltrichlorosilane
1744	Bromine <i>or Bromine solution</i>	1786	Hydrofluoric acid and sulphuric acid mixture
1745	Bromine pentafluoride	1787	Hydriodic acid
1746	Bromine trifluoride	1788	Hydrobromic acid, more than 49% strength <i>or Hydrobromic acid, not more than 49% strength</i>
1747	Butyltrichlorosilane	1789	Hydrochloric acid
1748	Calcium hypochlorite, dry <i>or Calcium hypochlorite mixture, dry with more than 39% available chlorine (8.8% available oxygen)</i>	1790	Hydrofluoric acid, with more than 60% strength <i>or Hydrofluoric acid, with not more than 60% strength</i>
1749	Chlorine trifluoride	1791	Hypochlorite solution
1750	Chloroacetic acid solution	1792	Iodine monochloride, solid
1751	Chloroacetic acid, solid	1793	Isopropyl acid phosphate
1752	Chloroacetyl chloride	1794	Lead sulphate with more than 3% free acid
1753	Chlorophenyltrichlorosilane	1796	Nitrating acid mixture with more than 50% nitric acid <i>or Nitrating acid mixture with not more than 50% nitric acid</i>
1754	Chlorosulphonic acid (with or without sulphur trioxide)	1798	Nitrohydrochloric acid
1755	Chromic acid solution	1799	Nonyltrichlorosilane
1756	Chromic fluoride, solid	1800	Octadecyltrichlorosilane
1757	Chromic fluoride solution	1801	Octyltrichlorosilane
1758	Chromium oxychloride	1802	Perchloric acid with not more than 50% acid, by mass
1759	Corrosive solid, n.o.s.	1803	Phenolsulphonic acid, liquid
1760	Corrosive liquid, n.o.s.	1804	Phenyltrichlorosilane
1761	Cupriethylenediamine solution		

1805	Phosphoric acid, solution	1848	Propionic acid with not less than 10% and less than 90% acid by mass
1806	Phosphorus pentachloride	1849	Sodium sulphide, hydrated with not less than 30% water
1807	Phosphorus pentoxide	1851	Medicine, liquid, toxic, n.o.s.
1808	Phosphorus tribromide	1854	Barium alloys, pyrophoric
1809	Phosphorus trichloride	1855	Calcium alloys, pyrophoric <i>or Calcium, pyrophoric</i>
1810	Phosphorus oxychloride	1856	Rags, oily
1811	Potassium hydrogendifluoride, solid	1857	Textile waste, wet
1812	Potassium fluoride, solid	1858	Hexafluoropropylene <i>or Refrigerant gas R 1216</i>
1813	Potassium hydroxide, solid	1859	Silicon tetrafluoride
1814	Potassium hydroxide solution	1860	Vinyl fluoride, stabilized
1815	Propionyl chloride	1862	Ethyl crotonate
1816	Propyltrichlorosilane	1863	Fuel, aviation, turbine engine
1817	Pyrosulphuryl chloride	1865	n-Propyl nitrate
1818	Silicon tetrachloride	1866	Resin solution, flammable
1819	Sodium aluminate solution	1868	Decaborane
1823	Sodium hydroxide, solid	1869	Magnesium in pellets, turnings or ribbons <i>or Magnesium alloys</i> with more than 50% magnesium in pellets, turnings or ribbons
1824	Sodium hydroxide solution	1870	Potassium borohydride
1825	Sodium monoxide	1871	Titanium hydride
1826	Nitrating acid mixture, spent with more than 50% nitric acid <i>or Nitrating acid mixture, spent</i> with not more than 50% nitric acid	1872	Lead dioxide
1827	Stannic chloride, anhydrous	1873	Perchloric acid with more than 50% but not more than 72% acid, by mass
1828	Sulphur chlorides	1884	Barium oxide
1829	Sulphur trioxide, stabilized	1885	Benzidine
1830	Sulphuric acid with more than 51% acid	1886	Benzylidene chloride
1831	Sulphuric acid, fuming	1887	Bromochloromethane
1832	Sulphuric acid, spent	1888	Chloroform
1833	Sulphurous acid	1889	Cyanogen bromide
1834	Sulphuryl chloride	1891	Ethyl bromide
1835	Tetramethylammonium hydroxide solution	1892	Ethyldichloroarsine
1836	Thionyl chloride	1894	Phenylmercuric hydroxide
1837	Thiophosphoryl chloride	1895	Phenylmercuric nitrate
1838	Titanium tetrachloride	1897	Tetrachloroethylene
1839	Trichloroacetic acid	1898	Acetyl iodide
1840	Zinc chloride solution	1902	Diisooctyl acid phosphate
1841	Acetaldehyde ammonia	1903	Disinfectant, liquid, corrosive, n.o.s.
1843	Ammonium dinitro-o-cresolate, solid	1905	Selenic acid
1845	Carbon dioxide, solid <i>or Dry ice</i>	1906	Sludge acid
1846	Carbon tetrachloride	1907	Soda lime with more than 4% sodium hydroxide
1847	Potassium sulphide, hydrated with not less than 30% water of crystallization	1908	Chlorite solution

1910	Calcium oxide	<i>or</i> Aerosols , non-flammable
1911	Diborane	<i>or</i> Aerosols , non-flammable, containing substances in Class 8, Packing Group II
1912	Methyl chloride and methylene chloride mixture	<i>or</i> Aerosols , non-flammable, containing substances in Division 6.1, Packing Group III and substances in Class 8, Packing Group III
1913	Neon, refrigerated liquid	<i>or</i> Aerosols , non-flammable, containing substances in Division 6.1, Packing Group II (other than tear gas devices)
1914	Butyl propionates	<i>or</i> Aerosols , non-flammable, containing toxic gas
1915	Cyclohexanone	<i>or</i> Aerosols , non-flammable, corrosive, containing substances in Class 8, Packing Group III
1916	2,2'-Dichlorodiethyl ether	<i>or</i> Aerosols , non-flammable (tear gas devices)
1917	Ethyl acrylate, stabilized	<i>or</i> Aerosols , non-flammable, toxic, containing substances in Division 6.1, Packing Group III
1918	Isopropylbenzene	<i>or</i> Aerosols , oxidizing
1919	Methyl acrylate, stabilized	
1920	Nonanes	
1921	Propyleneimine, stabilized	
1922	Pyrrolidine	
1923	Calcium dithionite	
	<i>or</i> Calcium hydrosulphite	
1928	Methyl magnesium bromide in ethyl ether	1951 Argon, refrigerated liquid
1929	Potassium dithionite	1952 Ethylene oxide and carbon dioxide mixture , with not more than 9% ethylene oxide
	<i>or</i> Potassium hydrosulphite	
1931	Zinc dithionite	1953 Compressed gas, toxic, flammable, n.o.s.
	<i>or</i> Zinc hydrosulphite	1954 Compressed gas, flammable, n.o.s.
1932	Zirconium scrap	1955 Compressed gas, toxic, n.o.s.
1935	Cyanide solution, n.o.s.	1956 Compressed gas, n.o.s.
1938	Bromoacetic acid solution	1957 Deuterium, compressed
1939	Phosphorus oxybromide	1958 1,2-Dichloro-1,1,2,2-tetrafluoroethane
1940	Thioglycolic acid	<i>or</i> Refrigerant gas R 114
1941	Dibromodifluoromethane	1959 1,1-Difluoroethylene
1942	Ammonium nitrate with not more than 0.2% combustible substances, including any organic substance calculated as carbon, to the exclusion of any other added substance	<i>or</i> Refrigerant gas R 1132a
1944	Matches, safety (book, card or strike on box)	1961 Ethane, refrigerated liquid
1945	Matches, wax 'vesta'	1962 Ethylene
1950	Aerosols, flammable	1963 Helium, refrigerated liquid
	<i>or</i> Aerosols , flammable, containing substances in Division 6.1, Packing Group II	1964 Hydrocarbon gas mixture, compressed, n.o.s.
	<i>or</i> Aerosols , flammable, containing substances in Division 6.1, Packing Group III and substances in Class 8, Packing Group III	1965 Hydrocarbon gas mixture, liquefied, n.o.s.
	<i>or</i> Aerosols , flammable, containing toxic gas	1966 Hydrogen, refrigerated liquid
	<i>or</i> Aerosols , flammable, corrosive, containing substances in Class 8, Packing Group II	1967 Insecticide gas, toxic, n.o.s.
	<i>or</i> Aerosols , flammable, corrosive, containing substances in Class 8, Packing Group III	1968 Insecticide gas, n.o.s.
	<i>or</i> Aerosols , flammable (engine starting fluid)	1969 Isobutane
	<i>or</i> Aerosols , flammable, toxic, containing substances in Division 6.1, Packing Group III	1970 Krypton, refrigerated liquid
		1971 Methane, compressed
		<i>or</i> Natural gas, compressed with high methane content
		1972 Methane, refrigerated liquid with high methane content
		<i>or</i> Natural gas, refrigerated liquid with high methane content

1973	Chlorodifluoromethane and chloropentafluoroethane mixture with fixed boiling point, with approximately 49% chlorodifluoromethane <i>or</i> Refrigerant gas R 502	<i>or</i> Hydrogen peroxide, aqueous solution with not less than 20% but not more than 40% hydrogen peroxide (stabilized as necessary)
1974	Chlorodifluorobromomethane <i>or</i> Refrigerant gas R 12B1	2015 Hydrogen peroxide, aqueous solution, stabilized with more than 60% hydrogen peroxide <i>or</i> Hydrogen peroxide, stabilized
1975	Nitric oxide and dinitrogen tetroxide mixture <i>or</i> Nitric oxide and nitrogen dioxide mixture	2016 Ammunition, toxic, non-explosive without burster or expelling charge, non-fuzed
1976	Octafluorocyclobutane <i>or</i> Refrigerant gas R C318	2017 Ammunition, tear-producing, non-explosive without burster or expelling charge, non-fuzed
1977	Nitrogen, refrigerated liquid	2018 Chloroanilines, solid
1978	Propane	2019 Chloroanilines, liquid
1982	Refrigerant gas R 14 <i>or</i> Tetrafluoromethane	2020 Chlorophenols, solid
1983	1-Chloro-2,2,2-trifluoroethane <i>or</i> Refrigerant gas R 133a	2021 Chlorophenols, liquid
1984	Refrigerant gas R 23 <i>or</i> Trifluoromethane	2022 Cresylic acid
1986	Alcohols, flammable, toxic, n.o.s.	2023 Epichlorohydrin
1987	Alcohols, n.o.s.	2024 Mercury compound, liquid, n.o.s.
1988	Aldehydes, flammable, toxic, n.o.s.	2025 Mercury compound, solid, n.o.s.
1989	Aldehydes, n.o.s.	2026 Phenylmercuric compound, n.o.s.
1990	Benzaldehyde	2027 Sodium arsenite, solid
1991	Chloroprene, stabilized	2028 Bombs, smoke, non-explosive with corrosive liquid, without initiating device
1992	Flammable liquid, toxic, n.o.s.	2029 Hydrazine, anhydrous
1993	Flammable liquid, n.o.s.	2030 Hydrazine, aqueous solution with more than 37% hydrazine by mass
1994	Iron pentacarbonyl	2031 Nitric acid , other than red fuming, with at least 65% but not more than 70% nitric acid <i>or</i> Nitric acid , other than red fuming, with more than 20% and less than 65% nitric acid
1999	Tars, liquid , including road oils, and cutback bitumens	<i>or</i> Nitric acid , other than red fuming, with more than 70% nitric acid
2000	Celluloid , in blocks, rods, rolls, sheets, tubes, etc. (except scrap)	<i>or</i> Nitric acid , other than red fuming, with not more than 20% nitric acid
2001	Cobalt naphthenates, powder	2032 Nitric acid, red fuming
2002	Celluloid, scrap	2033 Potassium monoxide
2004	Magnesium diamide	2034 Hydrogen and methane mixture, compressed
2006	Plastics, nitrocellulose-based, self-heating, n.o.s.	2035 Refrigerant gas R 143a <i>or</i> 1,1,1-Trifluoroethane
2008	Zirconium powder, dry	2036 Xenon
2009	Zirconium, dry , finished sheets, strip or coiled wire (thinner than 18 microns)	2037 Gas cartridges , (flammable) without a release device, non-refillable <i>or</i> Gas cartridges (non-flammable) without a release device, non-refillable <i>or</i> Gas cartridges (oxidizing) without a release device, non-refillable <i>or</i> Gas cartridges (toxic & corrosive) without a release device, non-refillable
2010	Magnesium hydride	
2011	Magnesium phosphide	
2012	Potassium phosphide	
2013	Strontium phosphide	
2014	Hydrogen peroxide, aqueous solution with more than 40% but not more than 60% hydrogen peroxide (stabilized as necessary)	

<i>or Gas cartridges</i> (toxic, flammable & corrosive) without a release device, non-refillable	2059	Nitrocellulose solution, flammable with not more than 12.6% nitrogen, by dry mass, and not more than 55% nitrocellulose
<i>or Gas cartridges</i> (toxic & flammable) without a release device, non-refillable	2067	Ammonium nitrate based fertilizer
<i>or Gas cartridges</i> (toxic, oxidizing & corrosive) without a release device, non-refillable	2071	Ammonium nitrate based fertilizer
<i>or Gas cartridges</i> (toxic & oxidizing) without a release device, non-refillable	2073	Ammonia solution , relative density less than 0.880 at 15°C in water, with more than 35% but not more than 50% ammonia
<i>or Gas cartridges</i> (toxic) without a release device, non-refillable	2074	Acrylamide, solid
<i>or Receptacles, small, containing gas</i> (flammable) without a release device, non-refillable	2075	Chloral, anhydrous, stabilized
<i>or Receptacles, small, containing gas</i> (non-flammable) without a release device, non-refillable	2076	Cresols, liquid
<i>or Receptacles, small, containing gas</i> (oxidizing) without a release device, non-refillable	2077	alpha-Naphthylamine
<i>or Receptacles, small, containing gas</i> (toxic & corrosive) without a release device, non-refillable	2078	Toluene diisocyanate
<i>or Receptacles, small, containing gas</i> (toxic, flammable & corrosive) without a release device, non-refillable	2079	Diethylenetriamine
<i>or Receptacles, small, containing gas</i> (toxic & oxidizing) without a release device, non-refillable	2186	Hydrogen chloride, refrigerated liquid
<i>or Receptacles, small, containing gas</i> (toxic & oxidizing) without a release device, non-refillable	2187	Carbon dioxide, refrigerated liquid
<i>or Receptacles, small, containing gas</i> (toxic & oxidizing) without a release device, non-refillable	2188	Arsine
<i>or Receptacles, small, containing gas</i> (toxic & oxidizing) without a release device, non-refillable	2189	Dichlorosilane
<i>or Receptacles, small, containing gas</i> (toxic & oxidizing) without a release device, non-refillable	2190	Oxygen difluoride, compressed
<i>or Receptacles, small, containing gas</i> (toxic & oxidizing) without a release device, non-refillable	2191	Sulphuryl fluoride
<i>or Receptacles, small, containing gas</i> (toxic & oxidizing) without a release device, non-refillable	2192	Germane
<i>or Receptacles, small, containing gas</i> (toxic & oxidizing) without a release device, non-refillable	2193	Hexafluoroethane <i>or Refrigerant gas R 116</i>
2038 Dinitrotoluenes, liquid	2194	Selenium hexafluoride
2044 2,2-Dimethylpropane	2195	Tellurium hexafluoride
2045 Isobutyl aldehyde <i>or Isobutyraldehyde</i>	2196	Tungsten hexafluoride
2046 Cymenes	2197	Hydrogen iodide, anhydrous
2047 Dichloropropenes	2198	Phosphorus pentafluoride
2048 Dicyclopentadiene	2199	Phosphine
2049 Diethylbenzene	2200	Propadiene, stabilized
2050 Diisobutylene, isomeric compounds	2201	Nitrous oxide, refrigerated liquid
2051 2-Dimethylaminoethanol	2202	Hydrogen selenide, anhydrous
2052 Dipentene	2203	Silane
2053 Methyl isobutyl carbinol	2204	Carbonyl sulphide
2054 Morpholine	2205	Adiponitrile
2055 Styrene monomer, stabilized	2206	Isocyanate solution, toxic, n.o.s. <i>or Isocyanates, toxic, n.o.s.</i>
2056 Tetrahydrofuran	2208	Calcium hypochlorite mixture, dry with more than 10% but not more than 39% available chlorine
2057 Tripropylene	2209	Formaldehyde solution with not less than 25% formaldehyde
2058 Valeraldehyde	2210	Maneb <i>or Maneb preparation</i> with not less than 60% maneb
	2211	Polymeric beads, expandable, evolving flammable

2212	Asbestos, amphibole (amosite, tremolite, actinolite, anthophyllite, crocidolite)	2258	1,2-Propylenediamine
2213	Paraformaldehyde	2259	Triethylenetetramine
2214	Phthalic anhydride with more than 0.05% of maleic anhydride	2260	Tripropylamine
2215	Maleic anhydride <i>or</i> Maleic anhydride, molten	2261	Xylenols, solid
2216	Fish meal, stabilized <i>or</i> Fish scrap, stabilized	2262	Dimethylcarbamoyl chloride
2217	Seed cake with not more than 1.5% oil and not more than 11% moisture	2263	Dimethylcyclohexanes
2218	Acrylic acid, stabilized	2264	N,N-Dimethylcyclohexylamine
2219	Allyl glycidyl ether	2265	N,N-Dimethylformamide
2222	Anisole	2266	Dimethyl-N-propylamine
2224	Benzonitrile	2267	Dimethyl thiophosphoryl chloride
2225	Benzenesulphonyl chloride	2269	3,3'-Iminodipropylamine
2226	Benzotrichloride	2270	Ethylamine, aqueous solution with not less than 50% but not more than 70% ethylamine
2227	n-Butyl methacrylate, stabilized	2271	Ethyl amyl ketone
2232	2-Chloroethanal	2272	N-Ethylaniline
2233	Chloroanisidines	2273	2-Ethylaniline
2234	Chlorobenzotrifluorides	2274	N-Ethyl-N-benzylaniline
2235	Chlorobenzyl chlorides, liquid	2275	2-Ethylbutanol
2236	3-Chloro-4-methylphenyl isocyanate, liquid	2276	2-Ethylhexylamine
2237	Chloronitroanilines	2277	Ethyl methacrylate, stabilized
2238	Chlorotoluenes	2278	n-Heptene
2239	Chlorotoluidines, solid	2279	Hexachlorobutadiene
2240	Chromosulphuric acid	2280	Hexamethylenediamine, solid
2241	Cycloheptane	2281	Hexamethylene diisocyanate
2242	Cycloheptene	2282	Hexanols
2243	Cyclohexyl acetate	2283	Isobutyl methacrylate, stabilized
2244	Cyclopentanol	2284	Isobutyronitrile
2245	Cyclopentanone	2285	Isocyanatobenzotrifluorides
2246	Cyclopentene	2286	Pentamethylheptane
2247	n-Decane	2287	Isoheptene
2248	Di-n-butylamine	2288	Isohexene
2249	Dichlorodimethyl ether, symmetrical	2289	Isophoronediamine
2250	Dichlorophenyl isocyanates	2290	Isophorone diisocyanate
2251	Bicyclo [2.2.1] hepta-2-5-diene, stabilized <i>or</i> 2,5-Norbornadiene, stabilized	2291	Lead compound, soluble, n.o.s.
2252	1,2-Dimethoxyethane	2293	4-Methoxy-4-methylpentan-2-one
2253	N,N-Dimethylaniline	2294	N-Methylaniline
2254	Matches, fusee	2295	Methyl chloroacetate
2256	Cyclohexene	2296	Methylcyclohexane
2257	Potassium	2297	Methylcyclohexanone
		2298	Methylcyclopentane
		2299	Methyl dichloroacetate
		2300	2-Methyl-5-ethylpyridine
		2301	2-Methylfuran

2302	5-Methylhexan-2-one	2345	3-Bromopropyne
2303	Isopropenylbenzene	2346	Butanedione
2304	Naphthalene, molten	2347	Butyl mercaptan
2305	Nitrobenzenesulphonic acid	2348	Butyl acrylates, stabilized
2306	Nitrobenzotrifluorides, liquid	2350	Butyl methyl ether
2307	3-Nitro-4-chlorobenzotrifluoride	2351	Butyl nitrites
2308	Nitrosylsulphuric acid, liquid	2352	Butyl vinyl ether, stabilized
2309	Octadiene	2353	Butyryl chloride
2310	Pentane-2,4-dione	2354	Chloromethyl ethyl ether
2311	Phenetidines	2356	2-Chloropropane
2312	Phenol, molten	2357	Cyclohexylamine
2313	Picolines	2358	Cyclooctatetraene
2315	Polychlorinated biphenyls, liquid	2359	Diallylamine
2316	Sodium cuprocyanide, solid	2360	Diallyl ether
2317	Sodium cuprocyanide solution	2361	Diisobutylamine
2318	Sodium hydrosulphide with less than 25% water of crystallization	2362	1,1-Dichloroethane
2319	Terpene hydrocarbons, n.o.s.	2363	Ethyl mercaptan
2320	Tetraethylenepentamine	2364	n-Propylbenzene
2321	Trichlorobenzenes, liquid	2366	Diethyl carbonate
2322	Trichlorobutene	2367	alpha-Methylvaleraldehyde
2323	Triethyl phosphite	2368	alpha-Pinene
2324	Triisobutylene	2370	1-Hexene
2325	1,3,5-Trimethylbenzene	2371	Isopentenes
2326	Trimethylcyclohexylamine	2372	1,2-Di-(dimethylamino) ethane
2327	Trimethylhexamethylenediamines	2373	Diethoxymethane
2328	Trimethylhexamethylene diisocyanate	2374	3,3-Diethoxypropene
2329	Trimethyl phosphite	2375	Diethyl sulphide
2330	Undecane	2376	2,3-Dihydropyran
2331	Zinc chloride, anhydrous	2377	1,1-Dimethoxyethane
2332	Acetaldehyde oxime	2378	2-Dimethylaminoacetonitrile
2333	Allyl acetate	2379	1,3-Dimethylbutylamine
2334	Allylamine	2380	Dimethyldiethoxysilane
2335	Allyl ethyl ether	2381	Dimethyl disulphide
2336	Allyl formate	2382	Dimethylhydrazine, symmetrical
2337	Phenyl mercaptan	2383	Dipropylamine
2338	Benzotrifluoride	2384	Di-n-propyl ether
2339	2-Bromobutane	2385	Ethyl isobutyrate
2340	2-Bromoethyl ethyl ether	2386	1-Ethylpiperidine
2341	1-Bromo-3-methylbutane	2387	Fluorobenzene
2342	Bromomethylpropanes	2388	Fluorotoluenes
2343	2-Bromopentane	2389	Furan
2344	Bromopropanes	2390	2-Iodobutane
		2391	Iodomethylpropanes

2392	Iodopropanes	2437	Methylphenyldichlorosilane
2393	Isobutyl formate	2438	Trimethylacetyl chloride
2394	Isobutyl propionate	2439	Sodium hydrogendifluoride
2395	Isobutyryl chloride	2440	Stannic chloride pentahydrate
2396	Methacrylaldehyde, stabilized	2441	Titanium trichloride mixture, pyrophoric <i>or</i> Titanium trichloride, pyrophoric
2397	3-Methylbutan-2-one	2442	Trichloroacetyl chloride
2398	Methyl tert-butyl ether	2443	Vanadium oxytrichloride
2399	1-Methylpiperidine	2444	Vanadium tetrachloride
2400	Methyl isovalerate	2446	Nitrocresols, solid
2401	Piperidine	2447	Phosphorus, white, molten
2402	Propanethiols	2448	Sulphur, molten
2403	Isopropenyl acetate	2451	Nitrogen trifluoride
2404	Propionitrile	2452	Ethylacetylene, stabilized
2405	Isopropyl butyrate	2453	Ethyl fluoride <i>or</i> Refrigerant gas R 161
2406	Isopropyl isobutyrate		
2407	Isopropyl chloroformate		
2409	Isopropyl propionate		
2410	1,2,3,6-Tetrahydropyridine	2454	Methyl fluoride <i>or</i> Refrigerant gas R 41
2411	Butyronitrile		
2412	Tetrahydrothiophene	2456	2-Chloropropene
2413	Tetrapropyl orthotitanate	2457	2,3-Dimethylbutane
2414	Thiophene	2458	Hexadiene
2416	Trimethyl borate	2459	2-Methyl-1-butene
2417	Carbonyl fluoride	2460	2-Methyl-2-butene
2418	Sulphur tetrafluoride	2461	Methylpentadiene
2419	Bromotrifluoroethylene	2463	Aluminium hydride
2420	Hexafluoroacetone	2464	Beryllium nitrate
2421	Nitrogen trioxide	2465	Dichloroisocyanuric acid, dry <i>or</i> Dichloroisocyanuric acid salts
2422	Octafluorobut-2-ene <i>or</i> Refrigerant gas R 1318	2466	Potassium superoxide
2424	Octafluoropropane <i>or</i> Refrigerant gas R 218	2468	Trichloroisocyanuric acid, dry
2426	Ammonium nitrate, liquid (hot concentrated solution)	2469	Zinc bromate
2427	Potassium chlorate, aqueous solution	2470	Phenylacetonitrile, liquid
2428	Sodium chlorate, aqueous solution	2471	Osmium tetroxide
2429	Calcium chlorate, aqueous solution	2473	Sodium arsenilate
2430	Alkylphenols, solid, n.o.s. (including C₂-C₁₂ homologues)	2474	Thiophosgene
2431	Anisidines	2475	Vanadium trichloride
2432	N,N-Diethylaniline	2477	Methyl isothiocyanate
2433	Chloronitrotoluenes, liquid	2478	Isocyanates, flammable, toxic, n.o.s. <i>or</i> Isocyanate solution, flammable, toxic, n.o.s.
2434	Dibenzylchlorosilane	2480	Methyl isocyanate
2435	Ethylphenyldichlorosilane	2481	Ethyl isocyanate
2436	Thioacetic acid	2482	n-Propyl isocyanate

2483	Isopropyl isocyanate	2535	4-Methylmorpholine <i>or N-Methylmorpholine</i>
2484	tert-Butyl isocyanate		
2485	n-Butyl isocyanate	2536	Methyltetrahydrofuran
2486	Isobutyl isocyanate	2538	Nitronaphthalene
2487	Phenyl isocyanate	2541	Terpinolene
2488	Cyclohexyl isocyanate	2542	Tributylamine
2490	Dichloroisopropyl ether	2545	Hafnium powder, dry
2491	Ethanolamine <i>or Ethanolamine solution</i>	2546	Titanium powder, dry
2493	Hexamethyleneimine	2547	Sodium superoxide
2495	Iodine pentafluoride	2548	Chlorine pentafluoride
2496	Propionic anhydride	2552	Hexafluoroacetone hydrate, liquid
2498	1,2,3,6-Tetrahydrobenzaldehyde	2554	Methylallyl chloride
2501	Tris-(1-aziridinyl) phosphine oxide solution	2555	Nitrocellulose with water , not less than 25% water by mass
2502	Valeryl chloride	2556	Nitrocellulose with alcohol , not less than 25% alcohol, by mass, and not more than 12.6% nitrogen, by dry mass
2503	Zirconium tetrachloride		
2504	Tetrabromoethane	2557	Nitrocellulose , with not more than 12.6% nitrogen, by dry mass, mixture without plasticizer, without pigment <i>or Nitrocellulose</i> , with not more than 12.6% nitrogen, by dry mass, mixture without plasticizer, with pigment <i>or Nitrocellulose</i> , with not more than 12.6% nitrogen, by dry mass, mixture with plasticizer, without pigment <i>or Nitrocellulose</i> , with not more than 12.6% nitrogen, by dry mass, mixture with plasticizer, with pigment
2505	Ammonium fluoride		
2506	Ammonium hydrogen sulphate		
2507	Chloroplatinic acid, solid		
2508	Molybdenum pentachloride		
2509	Potassium hydrogen sulphate		
2511	2-Chloropropionic acid		
2512	Aminophenols (o-,m-,p-)	2558	Epibromohydrin
2513	Bromoacetyl bromide	2560	2-Methylpentan-2-ol
2514	Bromobenzene	2561	3-Methyl-1-butene
2515	Bromoform	2564	Trichloroacetic acid solution
2516	Carbon tetrabromide	2565	Dicyclohexylamine
2517	1-Chloro-1,1-difluoroethane <i>or Refrigerant gas R 142b</i>	2567	Sodium pentachlorophenate
2518	1,5,9-Cyclododecatriene	2570	Cadmium compound
2520	Cyclooctadienes	2571	Alkylsulphuric acids
2521	Diketene, stabilized	2572	Phenylhydrazine
2522	2-Dimethylaminoethyl methacrylate	2573	Thallium chlorate
2524	Ethyl orthoformate	2574	Tricresyl phosphate with more than 3% ortho isomer
2525	Ethyl oxalate	2576	Phosphorus oxybromide, molten
2526	Furfurylamine	2577	Phenylacetyl chloride
2527	Isobutyl acrylate, stabilized	2578	Phosphorus trioxide
2528	Isobutyl isobutyrate	2579	Piperazine
2529	Isobutyric acid	2580	Aluminium bromide solution
2531	Methacrylic acid, stabilized	2581	Aluminium chloride solution
2533	Methyl trichloroacetate	2582	Ferric chloride solution
2534	Methylchlorosilane	2583	Alkylsulphonic acids, solid with more than 5% free sulphuric acid

	<i>or Arylsulphonic acids, solid</i> with more than 5% free sulphuric acid	2623	Firelighters, solid with flammable liquid
2584	Alkylsulphonic acids, liquid with more than 5% free sulphuric acid	2624	Magnesium silicide
	<i>or Arylsulphonic acids, liquid</i> with more than 5% free sulphuric acid	2626	Chloric acid, aqueous solution with not more than 10% chloric acid
2585	Alkylsulphonic acids, solid with not more than 5% free sulphuric acid	2627	Nitrites, inorganic, n.o.s.
	<i>or Arylsulphonic acids, solid</i> with not more than 5% free sulphuric acid	2628	Potassium fluoroacetate
2586	Alkylsulphonic acids, liquid with not more than 5% free sulphuric acid	2629	Sodium fluoroacetate
	<i>or Arylsulphonic acids, liquid</i> with not more than 5% free sulphuric acid	2630	Selenates <i>or Selenites</i>
2587	Benzoquinone	2642	Fluoroacetic acid
2588	Pesticide, solid, toxic, n.o.s.	2643	Methyl bromoacetate
2589	Vinyl chloroacetate	2644	Methyl iodide
2590	Asbestos, chrysotile	2645	Phenacyl bromide
2591	Xenon, refrigerated liquid	2646	Hexachlorocyclopentadiene
2599	Chlorotrifluoromethane and trifluoromethane azeotropic mixture with approximately 60% chlorotrifluoromethane <i>or Refrigerant gas R 503</i>	2647	Malononitrile
2601	Cyclobutane	2648	1,2-Dibromobutan-3-one
2602	Dichlorodifluoromethane and difluoroethane azeotropic mixture with approximately 74% dichlorodifluoromethane <i>or Refrigerant gas R 500</i>	2649	1,3-Dichloroacetone
2603	Cycloheptatriene	2650	1,1-Dichloro-1-nitroethane
2604	Boron trifluoride diethyl etherate	2651	4,4'-Diaminodiphenylmethane
2605	Methoxymethyl isocyanate	2653	Benzyl iodide
2606	Methyl orthosilicate	2655	Potassium fluorosilicate
2607	Acrolein dimer, stabilized	2656	Quinoline
2608	Nitropropanes	2657	Selenium disulphide
2609	Triallyl borate	2659	Sodium chloroacetate
2610	Triallylamine	2660	Nitrotoluidines (mono)
2611	Propylene chlorohydrin	2661	Hexachloroacetone
2612	Methyl propyl ether	2664	Dibromomethane
2614	Methallyl alcohol	2667	Butyltoluenes
2615	Ethyl propyl ether	2668	Chloroacetonitrile
2616	Triisopropyl borate	2669	Chlorocresols solution
2617	Methylcyclohexanols, flammable	2670	Cyanuric chloride
2618	Vinyltoluenes, stabilized	2671	Aminopyridines (o-,m-,p-)
2619	Benzyl dimethylamine	2672	Ammonia solution , relative density between 0.880 and 0.957 at 15°C in water, with more than 10% but not more than 35% ammonia
2620	Amyl butyrates	2673	2-Amino-4-chlorophenol
2621	Acetyl methyl carbinol	2674	Sodium fluorosilicate
2622	Glycidaldehyde	2676	Stibine
		2677	Rubidium hydroxide solution
		2678	Rubidium hydroxide
		2679	Lithium hydroxide solution
		2680	Lithium hydroxide
		2681	Caesium hydroxide solution
		2682	Caesium hydroxide

2683	Ammonium sulphide solution	2739	Butyric anhydride
2684	3-Diethylaminopropylamine	2740	n-Propyl chloroformate
2685	N,N-Diethylethylenediamine	2741	Barium hypochlorite with more than 22% available chlorine
2686	2-Diethylaminoethanol	2742	Chloroformates, toxic, corrosive, flammable, n.o.s.
2687	Dicyclohexylammonium nitrite	2743	n-Butyl chloroformate
2688	1-Bromo-3-chloropropane	2744	Cyclobutyl chloroformate
2689	Glycerol alpha-monochlorohydrin	2745	Chloromethyl chloroformate
2690	N,n-Butylimidazole	2746	Phenyl chloroformate
2691	Phosphorus pentabromide	2747	tert-Butylcyclohexyl chloroformate
2692	Boron tribromide	2748	2-Ethylhexyl chloroformate
2693	Bisulphites, aqueous solution, n.o.s.	2749	Tetramethylsilane
2698	Tetrahydrophthalic anhydrides with more than 0.05% of maleic anhydride	2750	1,3-Dichloropropanol-2
2699	Trifluoroacetic acid	2751	Diethylthiophosphoryl chloride
2705	1-Pentol	2752	1,2-Epoxy-3-ethoxypropane
2707	Dimethyldioxanes	2753	N-Ethylbenzyltoluidines, liquid
2709	Butylbenzenes	2754	N-Ethyltoluidines
2710	Dipropyl ketone	2757	Carbamate pesticide, solid, toxic
2713	Acridine	2758	Carbamate pesticide, liquid, flammable, toxic, flash point less than 23°C
2714	Zinc resinate	2759	Arsenical pesticide, solid, toxic
2715	Aluminium resinate	2760	Arsenical pesticide, liquid, flammable, toxic, flash point less than 23°C
2716	1,4-Butynediol	2761	Organochlorine pesticide, solid, toxic
2717	Camphor, synthetic	2762	Organochlorine pesticide, liquid, flammable, toxic, flash point less than 23°C
2719	Barium bromate	2763	Triazine pesticide, solid, toxic
2720	Chromium nitrate	2764	Triazine pesticide, liquid, flammable, toxic, flash point less than 23°C
2721	Copper chlorate	2771	Thiocarbamate pesticide, solid, toxic
2722	Lithium nitrate	2772	Thiocarbamate pesticide, liquid, flammable, toxic, flash point less than 23°C
2723	Magnesium chlorate	2775	Copper based pesticide, solid, toxic
2724	Manganese nitrate	2776	Copper based pesticide, liquid, flammable, toxic, flash point less than 23°C
2725	Nickel nitrate	2777	Mercury based pesticide, solid, toxic
2726	Nickel nitrite	2778	Mercury based pesticide, liquid, flammable, toxic, flash point less than 23°C
2727	Thallium nitrate	2779	Substituted nitrophenol pesticide, solid, toxic
2728	Zirconium nitrate	2780	Substituted nitrophenol pesticide, liquid, flammable, toxic, flash point less than 23°C
2729	Hexachlorobenzene	2781	Bipyridilium pesticide, solid, toxic
2730	Nitroanisoles, liquid	2782	Bipyridilium pesticide, liquid, flammable, toxic, flash point less than 23°C
2732	Nitrobromobenzene, liquid	2783	Organophosphorus pesticide, solid, toxic
2733	Amines, flammable, corrosive, n.o.s. <i>or Polyamines, flammable, corrosive, n.o.s.</i>		
2734	Amines, liquid, corrosive, flammable, n.o.s. <i>or Polyamines, liquid, corrosive, flammable, n.o.s.</i>		
2735	Amines, liquid, corrosive, n.o.s. <i>or Polyamines, liquid, corrosive, n.o.s.</i>		
2738	N-Butylaniline		

2784	Organophosphorus pesticide, liquid, flammable, toxic, flash point less than 23°C	2819	Amyl acid phosphate
2785	4-Thiapentanal	2820	Butyric acid
2786	Organotin pesticide, solid, toxic	2821	Phenol solution
2787	Organotin pesticide, liquid, flammable, toxic, flash point less than 23°C	2822	2-Chloropyridine
2788	Organotin compound, liquid, n.o.s.	2823	Crotonic acid, solid
2789	Acetic acid, glacial <i>or Acetic acid solution</i> , more than 80% acid, by mass	2826	Ethyl chlorothioformate
2790	Acetic acid solution , more than 10% but less than 50% acid, by mass <i>or Acetic acid solution</i> , not less than 50% but not more than 80% acid, by mass	2829	Caproic acid
2793	Ferrous metal borings in a form liable to self-heating <i>or Ferrous metal cuttings</i> in a form liable to self-heating <i>or Ferrous metal shavings</i> in a form liable to self-heating <i>or Ferrous metal turnings</i> in a form liable to self-heating	2830	Lithium ferrosilicon
2794	Batteries, wet, filled with acid , electric storage	2831	1,1,1-Trichloroethane
2795	Batteries, wet, filled with alkali , electric storage	2834	Phosphorous acid
2796	Battery fluid, acid <i>or Sulphuric acid</i> with not more than 51% acid	2835	Sodium aluminium hydride
2797	Battery fluid, alkali	2837	Bisulphates, aqueous solution
2798	Phenylphosphorus dichloride	2838	Vinyl butyrate, stabilized
2799	Phenylphosphorus thiodichloride	2839	Aldol
2800	Batteries, wet, non-spillable , electric storage	2840	Butyraldoxime
2801	Dye intermediate, liquid, corrosive, n.o.s. <i>or Dye, liquid, corrosive, n.o.s.</i>	2841	Di-n-amylamine
2802	Copper chloride	2842	Nitroethane
2803	Gallium	2844	Calcium manganese silicon
2805	Lithium hydride, fused solid	2845	Pyrophoric liquid, organic, n.o.s.
2806	Lithium nitride	2846	Pyrophoric solid, organic, n.o.s.
2807	Magnetized material	2849	3-Chloropropanol-1
2809	Mercury	2850	Propylene tetramer
2810	Toxic liquid, organic, n.o.s.	2851	Boron trifluoride dihydrate
2811	Toxic solid, organic, n.o.s.	2852	Dipicryl sulphide, wetted with not less than 10% water, by mass
2812	Sodium aluminate, solid	2853	Magnesium fluorosilicate
2813	Water-reactive solid, n.o.s.	2854	Ammonium fluorosilicate
2814	Infectious substance, affecting humans	2855	Zinc fluorosilicate
2815	N-Aminoethylpiperazine	2856	Fluorosilicates, n.o.s.
2817	Ammonium hydrogendifluoride solution	2857	Refrigerating machines containing non-flammable, non- toxic gases or ammonia solutions (UN 2672)
2818	Ammonium polysulphide solution	2858	Zirconium, dry , coiled wire, finished metal sheets, strip (thinner than 254 microns but not thinner than 18 microns)
		2859	Ammonium metavanadate
		2861	Ammonium polyvanadate
		2862	Vanadium pentoxide , non-fused form
		2863	Sodium ammonium vanadate
		2864	Potassium metavanadate
		2865	Hydroxylamine sulphate
		2869	Titanium trichloride mixture
		2870	Aluminium borohydride <i>or Aluminium borohydride in devices</i>
		2871	Antimony powder
		2872	Dibromochloropropanes

2873	Dibutylaminoethanol	2922	Corrosive liquid, toxic, n.o.s.
2874	Furfuryl alcohol	2923	Corrosive solid, toxic, n.o.s.
2875	Hexachlorophene	2924	Flammable liquid, corrosive, n.o.s.
2876	Resorcinol	2925	Flammable solid, corrosive, organic, n.o.s.
2878	Titanium sponge granules <i>or</i> Titanium sponge powders	2926	Flammable solid, toxic, organic, n.o.s.
2879	Selenium oxychloride	2927	Toxic liquid, corrosive, organic, n.o.s.
2880	Calcium hypochlorite, hydrated with not less than 5.5% but not more than 16% water <i>or</i> Calcium hypochlorite, hydrated mixture with not less than 5.5% but not more than 16% water	2928	Toxic solid, corrosive, organic, n.o.s.
2881	Metal catalyst, dry	2929	Toxic liquid, flammable, organic, n.o.s.
2900	Infectious substance, affecting animals only	2930	Toxic solid, flammable, organic, n.o.s.
2901	Bromine chloride	2931	Vanadyl sulphate
2902	Pesticide, liquid, toxic, n.o.s.	2933	Methyl 2-chloropropionate
2903	Pesticide, liquid, toxic, flammable, n.o.s. , flash point not less than 23°C	2934	Isopropyl 2-chloropropionate
2904	Chlorophenolates, liquid <i>or</i> Phenolates, liquid	2935	Ethyl 2-chloropropionate
2905	Chlorophenolates, solid <i>or</i> Phenolates, solid	2936	Thiolactic acid
2907	Isosorbide dinitrate mixture with not less than 60% lactose, mannose, starch or calcium hydrogen phosphate	2937	alpha-Methylbenzyl alcohol, liquid
2908	Radioactive material, excepted package — empty packaging	2940	Cyclooctadiene phosphines <i>or</i> 9-Phosphabicyclononanes
2909	Radioactive material, excepted package — articles manufactured from natural uranium or depleted uranium or natural thorium	2941	Fluoroanilines
2910	Radioactive material, excepted package — limited quantity of material	2942	2-Trifluoromethylaniline
2911	Radioactive material, excepted package — instruments or articles	2943	Tetrahydrofurfurylamine
2912	Radioactive material, low specific activity (LSA-I), non-fissile or fissile excepted	2945	N-Methylbutylamine
2913	Radioactive material, surface contaminated objects (SCO-I or SCO-II), non-fissile or fissile excepted	2946	2-Amino-5-diethylaminopentane
2915	Radioactive material, Type A package, non-special form, non-fissile or fissile excepted	2947	Isopropyl chloroacetate
2916	Radioactive material, Type B(U) package, non-fissile or fissile excepted	2948	3-Trifluoromethylaniline
2917	Radioactive material, Type B(M) package, non-fissile or fissile excepted	2949	Sodium hydrosulphide, hydrated with not less than 25% water of crystallization
2919	Radioactive material, transported under special arrangement, non-fissile or fissile excepted	2950	Magnesium granules, coated , particle size not less than 149 microns
2920	Corrosive liquid, flammable, n.o.s.	2956	5-tert-Butyl-2,4,6-trinitro-m-xylene <i>or</i> Musk xylene
2921	Corrosive solid, flammable, n.o.s.	2965	Boron trifluoride dimethyl etherate
		2966	Thioglycol
		2967	Sulphamic acid
		2968	Maneb preparation, stabilized against self-heating <i>or</i> Maneb stabilized against self-heating
		2969	Castor beans <i>or</i> Castor flake <i>or</i> Castor meal <i>or</i> Castor pomace
		2977	Radioactive material, uranium hexafluoride, fissile
		2978	Radioactive material, uranium hexafluoride, non-fissile or fissile excepted
		2983	Ethylene oxide and propylene oxide mixture , not more than 30% ethylene oxide

2984	Hydrogen peroxide, aqueous solution with not less than 8% but less than 20% hydrogen peroxide (stabilized as necessary)	3024	Coumarin derivative pesticide, liquid, flammable, toxic, flash point less than 23°C
2985	Chlorosilanes, flammable, corrosive, n.o.s.	3025	Coumarin derivative pesticide, liquid, toxic, flammable, flash point not less than 23°C
2986	Chlorosilanes, corrosive, flammable, n.o.s.	3026	Coumarin derivative pesticide, liquid, toxic
2987	Chlorosilanes, corrosive, n.o.s.	3027	Coumarin derivative pesticide, solid, toxic
2988	Chlorosilanes, water-reactive, flammable, corrosive, n.o.s.	3028	Batteries, dry, containing potassium hydroxide solid, electric storage
2989	Lead phosphite, dibasic	3048	Aluminium phosphide pesticide
2990	Life-saving appliances, self-inflating	3054	Cyclohexyl mercaptan
2991	Carbamate pesticide, liquid, toxic, flammable, flash point not less than 23°C	3055	2-(2-Aminoethoxy)ethanol
2992	Carbamate pesticide, liquid, toxic	3056	n-Heptaldehyde
2993	Arsenical pesticide, liquid, toxic, flammable, flash point not less than 23°C	3057	Trifluoroacetyl chloride
2994	Arsenical pesticide, liquid, toxic	3064	Nitroglycerin solution in alcohol with more than 1% but not more than 5% nitroglycerin
2995	Organochlorine pesticide, liquid, toxic, flammable, flash point not less than 23°C	3065	Alcoholic beverages containing more than 70% alcohol by volume <i>or Alcoholic beverages</i> containing more than 24% but not more than 70% alcohol by volume
2996	Organochlorine pesticide, liquid, toxic	3066	Paint (including paint, lacquer, enamel, stain, shellac, varnish, polish, liquid filler and liquid lacquer base) <i>or Paint related material</i> (including paint thinning or reducing compound)
2997	Triazine pesticide, liquid, toxic, flammable, flash point not less than 23°C	3070	Ethylene oxide and dichlorodifluoromethane mixture, with not more than 12.5% ethylene oxide
2998	Triazine pesticide, liquid, toxic	3071	Mercaptan mixture, liquid, toxic, flammable, n.o.s. <i>or Mercaptans, liquid, toxic, flammable, n.o.s.</i>
3005	Thiocarbamate pesticide, liquid, toxic, flammable, flash point not less than 23°C	3072	Life-saving appliances, not self-inflating containing dangerous goods as equipment
3006	Thiocarbamate pesticide, liquid, toxic	3073	Vinylpyridines, stabilized
3009	Copper based pesticide, liquid, toxic, flammable, flash point not less than 23°C	3077	Environmentally hazardous substance, solid, n.o.s.
3010	Copper based pesticide, liquid, toxic	3078	Cerium, turnings or gritty powder
3011	Mercury based pesticide, liquid, toxic, flammable, flash point not less than 23°C	3079	Methacrylonitrile, stabilized
3012	Mercury based pesticide, liquid, toxic	3080	Isocyanate solution, toxic, flammable, n.o.s. <i>or Isocyanates, toxic, flammable, n.o.s.</i>
3013	Substituted nitrophenol pesticide, liquid, toxic, flammable, flash point not less than 23°C	3082	Environmentally hazardous substance, liquid, n.o.s.
3014	Substituted nitrophenol pesticide, liquid, toxic	3083	Perchloryl fluoride
3015	Bipyridilium pesticide, liquid, toxic, flammable, flash point not less than 23°C	3084	Corrosive solid, oxidizing, n.o.s.
3016	Bipyridilium pesticide, liquid, toxic	3085	Oxidizing solid, corrosive, n.o.s.
3017	Organophosphorus pesticide, liquid, toxic, flammable, flash point not less than 23°C	3086	Toxic solid, oxidizing, n.o.s.
3018	Organophosphorus pesticide, liquid, toxic	3087	Oxidizing solid, toxic, n.o.s.
3019	Organotin pesticide, liquid, toxic, flammable, flash point not less than 23°C	3088	Self-heating solid, organic, n.o.s.
3020	Organotin pesticide, liquid, toxic	3089	Metal powder, flammable, n.o.s.
3021	Pesticide, liquid, flammable, toxic, n.o.s., flash point less than 23°C	3090	Lithium metal batteries (including lithium alloy batteries)
3022	1,2-Butylene oxide, stabilized	3091	Lithium metal batteries contained in equipment (including lithium alloy batteries)
3023	2-Methyl-2-heptanethiol		

	<i>or</i> Lithium metal batteries packed with equipment (including lithium alloy batteries)	3137	Oxidizing solid, flammable, n.o.s.
3092	1-Methoxy-2-propanol	3138	Ethylene, acetylene and propylene mixture, refrigerated liquid containing at least 71.5% ethylene with not more than 22.5% acetylene and not more than 6% propylene
3093	Corrosive liquid, oxidizing, n.o.s.	3139	Oxidizing liquid, n.o.s.
3094	Corrosive liquid, water-reactive, n.o.s.	3140	Alkaloid salts, liquid, n.o.s. <i>or</i> Alkaloids, liquid, n.o.s.
3095	Corrosive solid, self-heating, n.o.s.	3141	Antimony compound, inorganic, liquid, n.o.s.
3096	Corrosive solid, water-reactive, n.o.s.	3142	Disinfectant, liquid, toxic, n.o.s.
3097	Flammable solid, oxidizing, n.o.s.	3143	Dye intermediate, solid, toxic, n.o.s. <i>or</i> Dye, solid, toxic, n.o.s.
3098	Oxidizing liquid, corrosive, n.o.s.	3144	Nicotine compound, liquid, n.o.s. <i>or</i> Nicotine preparation, liquid, n.o.s.
3099	Oxidizing liquid, toxic, n.o.s.	3145	Alkylphenols, liquid, n.o.s. (including C ₂ -C ₁₂ homologues)
3100	Oxidizing solid, self-heating, n.o.s.	3146	Organotin compound, solid, n.o.s.
3103	Organic peroxide type C, liquid	3147	Dye intermediate, solid, corrosive, n.o.s. <i>or</i> Dye, solid, corrosive, n.o.s.
3104	Organic peroxide type C, solid	3148	Water-reactive liquid, n.o.s.
3105	Organic peroxide type D, liquid	3149	Hydrogen peroxide and peroxyacetic acid mixture with acid(s), water and not more than 5% peroxyacetic acid, stabilized
3106	Organic peroxide type D, solid	3150	Devices, small, hydrocarbon gas powered with release device <i>or</i> Hydrocarbon gas refills for small devices with release device
3107	Organic peroxide type E, liquid	3151	Polyhalogenated biphenyls, liquid <i>or</i> Polyhalogenated terphenyls, liquid
3108	Organic peroxide type E, solid	3152	Polyhalogenated biphenyls, solid <i>or</i> Polyhalogenated terphenyls, solid
3109	Organic peroxide type F, liquid	3153	Perfluoro (methyl vinyl ether)
3110	Organic peroxide type F, solid	3154	Perfluoro (ethyl vinyl ether)
3113	Organic peroxide type C, liquid, temperature controlled	3155	Pentachlorophenol
3114	Organic peroxide type C, solid, temperature controlled	3156	Compressed gas, oxidizing, n.o.s.
3115	Organic peroxide type D, liquid, temperature controlled	3157	Liquefied gas, oxidizing, n.o.s.
3116	Organic peroxide type D, solid, temperature controlled	3158	Gas, refrigerated liquid, n.o.s.
3117	Organic peroxide type E, liquid, temperature controlled	3159	Refrigerant gas R 134a <i>or</i> 1,1,1,2-Tetrafluoroethane
3118	Organic peroxide type E, solid, temperature controlled	3160	Liquefied gas, toxic, flammable, n.o.s.
3119	Organic peroxide type F, liquid, temperature controlled	3161	Liquefied gas, flammable, n.o.s.
3120	Organic peroxide type F, solid, temperature controlled	3162	Liquefied gas, toxic, n.o.s.
3121	Oxidizing solid, water-reactive, n.o.s.	3163	Liquefied gas, n.o.s.
3122	Toxic liquid, oxidizing, n.o.s.	3164	Articles, pressurized, hydraulic containing non-flammable gas
3123	Toxic liquid, water-reactive, n.o.s.		
3124	Toxic solid, self-heating, n.o.s.		
3125	Toxic solid, water-reactive, n.o.s.		
3126	Self-heating solid, corrosive, organic, n.o.s.		
3127	Self-heating solid, oxidizing, n.o.s.		
3128	Self-heating solid, toxic, organic, n.o.s.		
3129	Water-reactive liquid, corrosive, n.o.s.		
3130	Water-reactive liquid, toxic, n.o.s.		
3131	Water-reactive solid, corrosive, n.o.s.		
3132	Water-reactive solid, flammable, n.o.s.		
3133	Water-reactive solid, oxidizing, n.o.s.		
3134	Water-reactive solid, toxic, n.o.s.		
3135	Water-reactive solid, self-heating, n.o.s.		
3136	Trifluoromethane, refrigerated liquid		

	<i>or</i> Articles, pressurized, pneumatic containing non-flammable gas	3200	Pyrophoric solid, inorganic, n.o.s.
		3205	Alkaline earth metal alcoholates, n.o.s.
3165	Aircraft hydraulic power unit fuel tank (containing a mixture of anhydrous hydrazine and methyl hydrazine) (M86 fuel)	3206	Alkali metal alcoholates, self-heating, corrosive, n.o.s.
		3208	Metallic substance, water-reactive, n.o.s.
3166	Engine, fuel cell, flammable gas powered	3209	Metallic substance, water-reactive, self-heating, n.o.s.
	<i>or</i> Engine, fuel cell, flammable liquid powered	3210	Chlorates, inorganic, aqueous solution, n.o.s.
	<i>or</i> Engine, internal combustion, flammable gas powered	3211	Perchlorates, inorganic, aqueous solution, n.o.s.
	<i>or</i> Engine, internal combustion, flammable liquid powered	3212	Hypochlorites, inorganic, n.o.s.
	<i>or</i> Vehicle, flammable gas powered	3213	Bromates, inorganic, aqueous solution, n.o.s.
	<i>or</i> Vehicle, flammable liquid powered	3214	Permanganates, inorganic, aqueous solution, n.o.s.
	<i>or</i> Vehicle, fuel cell, flammable gas powered	3215	Persulphates, inorganic, n.o.s.
	<i>or</i> Vehicle, fuel cell, flammable liquid powered	3216	Persulphates, inorganic, aqueous solution, n.o.s.
3167	Gas sample, non-pressurized, flammable, n.o.s., not refrigerated liquid	3218	Nitrates, inorganic, aqueous solution, n.o.s.
		3219	Nitrites, inorganic, aqueous solution, n.o.s.
3168	Gas sample, non-pressurized, toxic, flammable, n.o.s., not refrigerated liquid	3220	Pentafluoroethane
			<i>or</i> Refrigerant gas R 125
3169	Gas sample, non-pressurized, toxic, n.o.s., not refrigerated liquid	3221	Self-reactive liquid type B
		3223	Self-reactive liquid type C
3170	Aluminium remelting by-products	3224	Self-reactive solid type C
	<i>or</i> Aluminium smelting by-products	3225	Self-reactive liquid type D
3171	Battery-powered equipment	3226	Self-reactive solid type D
	<i>or</i> Battery-powered vehicle	3227	Self-reactive liquid type E
3172	Toxins, extracted from living sources, liquid, n.o.s.	3228	Self-reactive solid type E
3174	Titanium disulphide	3229	Self-reactive liquid type F
3175	Solids containing flammable liquid, n.o.s.	3230	Self-reactive solid type F
3176	Flammable solid, organic, molten, n.o.s.	3231	Self-reactive liquid type B, temperature controlled
3178	Flammable solid, inorganic, n.o.s.	3233	Self-reactive liquid type C, temperature controlled
3179	Flammable solid, toxic, inorganic, n.o.s.	3234	Self-reactive solid type C, temperature controlled
3180	Flammable solid, corrosive, inorganic, n.o.s.	3235	Self-reactive liquid type D, temperature controlled
3181	Metal salts of organic compounds, flammable, n.o.s.	3236	Self-reactive solid type D, temperature controlled
3182	Metal hydrides, flammable, n.o.s.	3237	Self-reactive liquid type E, temperature controlled
3183	Self-heating liquid, organic, n.o.s.	3238	Self-reactive solid type E, temperature controlled
3184	Self-heating liquid, toxic, organic, n.o.s.	3239	Self-reactive liquid type F, temperature controlled
3185	Self-heating liquid, corrosive, organic, n.o.s.	3240	Self-reactive solid type F, temperature controlled
3186	Self-heating liquid, inorganic, n.o.s.	3241	2-Bromo-2-nitropropane-1,3-diol
3187	Self-heating liquid, toxic, inorganic, n.o.s.	3242	Azodicarbonamide
3188	Self-heating liquid, corrosive, inorganic, n.o.s.	3243	Solids containing toxic liquid, n.o.s.
3189	Metal powder, self-heating, n.o.s.	3244	Solids containing corrosive liquid, n.o.s.
3190	Self-heating solid, inorganic, n.o.s.	3245	Genetically modified micro-organisms
3191	Self-heating solid, toxic, inorganic, n.o.s.		<i>or</i> Genetically modified organisms
3192	Self-heating solid, corrosive, inorganic, n.o.s.	3246	Methanesulphonyl chloride
3194	Pyrophoric liquid, inorganic, n.o.s.		

3247	Sodium peroxoborate, anhydrous	3284	Tellurium compound, n.o.s.
3248	Medicine, liquid, flammable, toxic, n.o.s.	3285	Vanadium compound, n.o.s.
3249	Medicine, solid, toxic, n.o.s.	3286	Flammable liquid, toxic, corrosive, n.o.s.
3250	Chloroacetic acid, molten	3287	Toxic liquid, inorganic, n.o.s.
3251	Isosorbide-5-mononitrate	3288	Toxic solid, inorganic, n.o.s.
3252	Difluoromethane <i>or Refrigerant gas R 32</i>	3289	Toxic liquid, corrosive, inorganic, n.o.s.
3253	Disodium trioxosilicate	3290	Toxic solid, corrosive, inorganic, n.o.s.
3254	Tributylphosphane	3291	Biomedical waste, n.o.s. <i>or Clinical waste, unspecified, n.o.s.</i> <i>or Medical waste, n.o.s.</i> <i>or Regulated medical waste, n.o.s.</i>
3255	tert-Butyl hypochlorite	3292	Batteries, containing sodium <i>or Cells, containing sodium</i>
3256	Elevated temperature liquid, flammable, n.o.s., with flash point above 60°C, at or above its flash point	3293	Hydrazine, aqueous solution with not more than 37% hydrazine, by mass
3257	Elevated temperature liquid, n.o.s., at or above 100°C and below its flash point (including molten metals, molten salts, etc.)	3294	Hydrogen cyanide, solution in alcohol with not more than 45% hydrogen cyanide
3258	Elevated temperature solid, n.o.s., at or above 240°C	3295	Hydrocarbons, liquid, n.o.s.
3259	Amines, solid, corrosive, n.o.s. <i>or Polyamines, solid, corrosive, n.o.s.</i>	3296	Heptafluoropropane <i>or Refrigerant gas R 227</i>
3260	Corrosive solid, acidic, inorganic, n.o.s.	3297	Ethylene oxide and chlorotetrafluoroethane mixture, with not more than 8.8% ethylene oxide
3261	Corrosive solid, acidic, organic, n.o.s.	3298	Ethylene oxide and pentafluoroethane mixture, with not more than 7.9% ethylene oxide
3262	Corrosive solid, basic, inorganic, n.o.s.	3299	Ethylene oxide and tetrafluoroethane mixture, with not more than 5.6% ethylene oxide
3263	Corrosive solid, basic, organic, n.o.s.	3300	Ethylene oxide and carbon dioxide mixture, with more than 87% ethylene oxide
3264	Corrosive liquid, acidic, inorganic, n.o.s.	3301	Corrosive liquid, self-heating, n.o.s.
3265	Corrosive liquid, acidic, organic, n.o.s.	3302	2-Dimethylaminoethyl acrylate
3266	Corrosive liquid, basic, inorganic, n.o.s.	3303	Compressed gas, toxic, oxidizing, n.o.s.
3267	Corrosive liquid, basic, organic, n.o.s.	3304	Compressed gas, toxic, corrosive, n.o.s.
3268	Safety devices, electrically initiated	3305	Compressed gas, toxic, flammable, corrosive, n.o.s.
3269	Polyester resin kit	3306	Compressed gas, toxic, oxidizing, corrosive, n.o.s.
3270	Nitrocellulose membrane filters with not more than 12.6% nitrogen, by dry mass	3307	Liquefied gas, toxic, oxidizing, n.o.s.
3271	Ethers, n.o.s.	3308	Liquefied gas, toxic, corrosive, n.o.s.
3272	Esters, n.o.s.	3309	Liquefied gas, toxic, flammable, corrosive, n.o.s.
3273	Nitriles, flammable, toxic, n.o.s.	3310	Liquefied gas, toxic, oxidizing, corrosive, n.o.s.
3274	Alcoholates solution, n.o.s., in alcohol	3311	Gas, refrigerated liquid, oxidizing, n.o.s.
3275	Nitriles, toxic, flammable, n.o.s.	3312	Gas, refrigerated liquid, flammable, n.o.s.
3276	Nitriles, liquid, toxic, n.o.s.	3313	Organic pigments, self-heating
3277	Chloroformates, toxic, corrosive, n.o.s.	3314	Plastics moulding compound in dough, sheet or extruded rope form evolving flammable vapour
3278	Organophosphorus compound, liquid, toxic, n.o.s.	3315	Chemical sample, toxic
3279	Organophosphorus compound, toxic, flammable, n.o.s.	3316	Chemical kit
3280	Organoarsenic compound, liquid, n.o.s.		
3281	Metal carbonyls, liquid, n.o.s.		
3282	Organometallic compound, liquid, toxic, n.o.s.		
3283	Selenium compound, solid, n.o.s.		

	<i>or</i> First aid kit	3344	Pentaerythrite tetranitrate mixture desensitized, solid, n.o.s. with more than 10% but not more than 20% PETN, by mass
3317	2-Amino-4,6-dinitrophenol, wetted with not less than 20% water by mass		<i>or</i> Pentaerythritol tetranitrate mixture desensitized, solid, n.o.s. with more than 10% but not more than 20% PETN, by mass
3318	Ammonia solution , relative density less than 0.880 at 15°C in water, with more than 50% ammonia		<i>or</i> PETN mixture desensitized, solid, n.o.s. with more than 10% but not more than 20% PETN, by mass
3319	Nitroglycerin mixture, desensitized, solid, n.o.s. with more than 2% but not more than 10% nitroglycerin, by mass		
3320	Sodium borohydride and sodium hydroxide solution , with not more than 12% sodium borohydride and not more than 40% sodium hydroxide, by mass	3345	Phenoxyacetic acid derivative pesticide, solid, toxic
3321	Radioactive material, low specific activity (LSA-II) , non-fissile or fissile excepted	3346	Phenoxyacetic acid derivative pesticide, liquid, flammable, toxic , flash point less than 23°C
3322	Radioactive material, low specific activity (LSA-III) , non-fissile or fissile excepted	3347	Phenoxyacetic acid derivative pesticide, liquid, toxic, flammable , flash point not less than 23°C
3323	Radioactive material, Type C package , non-fissile or fissile excepted	3348	Phenoxyacetic acid derivative pesticide, liquid, toxic
3324	Radioactive material, low specific activity (LSA-II), fissile	3349	Pyrethroid pesticide, solid, toxic
3325	Radioactive material, low specific activity (LSA-III), fissile	3350	Pyrethroid pesticide, liquid flammable, toxic , flash point less than 23°C
3326	Radioactive material, surface contaminated objects (SCO-I or SCO-II) , fissile	3351	Pyrethroid pesticide, liquid, toxic, flammable , flash point not less than 23°C
3327	Radioactive material, Type A package, fissile , non-special form	3352	Pyrethroid pesticide, liquid, toxic
3328	Radioactive material, Type B(U) package, fissile	3354	Insecticide gas, flammable, n.o.s.
3329	Radioactive material, Type B(M) package, fissile	3355	Insecticide gas, toxic, flammable, n.o.s.
3330	Radioactive material, Type C package, fissile	3356	Oxygen generator, chemical (including when contained in associated equipment, e.g. passenger service units (PSUs), protective breathing equipment (PBE), etc.)
3331	Radioactive material, transported under special arrangement, fissile	3357	Nitroglycerin mixture, desensitized, liquid, n.o.s. with not more than 30% nitroglycerin, by mass
3332	Radioactive material, Type A package, special form , non-fissile or fissile excepted	3358	Refrigerating machines containing flammable, non-toxic, liquefied gas
3333	Radioactive material, Type A package, special form, fissile	3359	Fumigated cargo transport unit
3334	Aviation regulated liquid, n.o.s.	3360	Fibres, vegetable, dry
3335	Aviation regulated solid, n.o.s.	3361	Chlorosilanes, toxic, corrosive, n.o.s.
3336	Mercaptan mixture, liquid, flammable, n.o.s. <i>or</i> Mercaptans, liquid, flammable, n.o.s.	3362	Chlorosilanes, toxic, corrosive, flammable, n.o.s.
3337	Refrigerant gas R 404A	3363	Dangerous goods in apparatus <i>or</i> Dangerous goods in machinery
3338	Refrigerant gas R 407A	3364	Picric acid, wetted with not less than 10% water, by mass <i>or</i> Trinitrophenol, wetted with not less than 10% water, by mass
3339	Refrigerant gas R 407B	3365	Picryl chloride, wetted with not less than 10% water, by mass <i>or</i> Trinitrochlorobenzene, wetted with not less than 10% water, by mass
3340	Refrigerant gas R 407C	3366	TNT, wetted with not less than 10% water, by mass <i>or</i> Trinitrotoluene, wetted with not less than 10% water, by mass
3341	Thiourea dioxide	3367	Trinitrobenzene, wetted with not less than 10% water, by mass
3342	Xanthates		
3343	Nitroglycerin mixture, desensitized, liquid flammable, n.o.s. with not more than 30% nitroglycerin, by mass		

- 3368 **Trinitrobenzoic acid, wetted** with not less than 10% water, by mass
- 3369 **Sodium dinitro-o-cresolate, wetted** with not less than 10% water, by mass
- 3370 **Urea nitrate, wetted** with not less than 10% water, by mass
- 3371 **2-Methylbutanal**
- 3373 **Biological substance, Category B**
- 3374 **Acetylene, solvent free**
- 3375 **Ammonium nitrate emulsion** intermediate for blasting explosives
or Ammonium nitrate gel intermediate for blasting explosives
or Ammonium nitrate suspension intermediate for blasting explosives
- 3376 **4-Nitrophenylhydrazine** with not less than 30% water, by mass
- 3377 **Sodium perborate monohydrate**
- 3378 **Sodium carbonate peroxyhydrate**
- 3379 **Desensitized explosive, liquid, n.o.s.**
- 3380 **Desensitized explosive, solid, n.o.s.**
- 3381 **Toxic by inhalation liquid, n.o.s.** with an LC₅₀ lower than or equal to 200 mL/m³ and saturated vapour concentration greater than or equal to 500 LC₅₀
- 3382 **Toxic by inhalation liquid, n.o.s.** with an LC₅₀ lower than or equal to 1 000 mL/m³ and saturated vapour concentration greater than or equal to 10 LC₅₀
- 3383 **Toxic by inhalation liquid, flammable, n.o.s.** with an LC₅₀ lower than or equal to 200 mL/m³ and saturated vapour concentration greater than or equal to 500 LC₅₀
- 3384 **Toxic by inhalation liquid, flammable, n.o.s.** with an LC₅₀ lower than or equal to 1 000 mL/m³ and saturated vapour concentration greater than or equal to 10 LC₅₀
- 3385 **Toxic by inhalation liquid, water-reactive, n.o.s.** with an LC₅₀ lower than or equal to 200 mL/m³ and saturated vapour concentration greater than or equal to 500 LC₅₀
- 3386 **Toxic by inhalation liquid, water-reactive, n.o.s.** with an LC₅₀ lower than or equal to 1 000 mL/m³ and saturated vapour concentration greater than or equal to 10 LC₅₀
- 3387 **Toxic by inhalation liquid, oxidizing, n.o.s.** with an LC₅₀ lower than or equal to 200 mL/m³ and saturated vapour concentration greater than or equal to 500 LC₅₀
- 3388 **Toxic by inhalation liquid, oxidizing, n.o.s.** with an LC₅₀ lower than or equal to 1 000 mL/m³ and saturated vapour concentration greater than or equal to 10 LC₅₀
- 3389 **Toxic by inhalation liquid, corrosive, n.o.s.** with an LC₅₀ lower than or equal to 200 mL/m³ and saturated vapour concentration greater than or equal to 500 LC₅₀
- 3390 **Toxic by inhalation liquid, corrosive, n.o.s.** with an LC₅₀ lower than or equal to 1 000 mL/m³ and saturated vapour concentration greater than or equal to 10 LC₅₀
- 3391 **Organometallic substance, solid, pyrophoric**
- 3392 **Organometallic substance, liquid, pyrophoric**
- 3393 **Organometallic substance, solid, pyrophoric, water reactive**
- 3394 **Organometallic substance, liquid, pyrophoric, water reactive**
- 3395 **Organometallic substance, solid, water reactive**
- 3396 **Organometallic substance, solid, water reactive, flammable**
- 3397 **Organometallic substance, solid, water reactive, self-heating**
- 3398 **Organometallic substance, liquid, water reactive**
- 3399 **Organometallic substance, liquid, water reactive, flammable**
- 3400 **Organometallic substance, solid, self-heating**
- 3401 **Alkali metal amalgam, solid**
- 3402 **Alkaline earth metal amalgam, solid**
- 3403 **Potassium metal alloys, solid**
- 3404 **Potassium sodium alloys, solid**
- 3405 **Barium chlorate solution**
- 3406 **Barium perchlorate solution**
- 3407 **Chlorate and magnesium chloride mixture solution**
- 3408 **Lead perchlorate solution**
- 3409 **Chloronitrobenzenes, liquid**
- 3410 **4-Chloro-o-toluidine hydrochloride solution**
- 3411 **beta-Naphthylamine solution**
- 3412 **Formic acid** with not less than 5% but less than 10% acid by mass
or Formic acid with not less than 10% but not more than 85% acid by mass
- 3413 **Potassium cyanide solution**
- 3414 **Sodium cyanide solution**
- 3415 **Sodium fluoride solution**
- 3416 **Chloroacetophenone, liquid**
- 3417 **Xylyl bromide, solid**
- 3418 **2,4-Toluylenediamine solution**
- 3419 **Boron trifluoride acetic acid complex, solid**
- 3420 **Boron trifluoride propionic acid complex, solid**
- 3421 **Potassium hydrogendifluoride solution**
- 3422 **Potassium fluoride solution**
- 3423 **Tetramethylammonium hydroxide, solid**
- 3424 **Ammonium dinitro-o-cresolate solution**

3425	Bromoacetic acid, solid		<i>or</i> Hydrogen in a metal hydride storage system packed with equipment
3426	Acrylamide solution		
3427	Chlorobenzyl chlorides, solid	3469	Paint, flammable, corrosive (including paint, lacquer, enamel, stain, shellac, varnish, polish, liquid filler and liquid lacquer base)
3428	3-Chloro-4-methylphenyl isocyanate, solid		
3429	Chlorotoluidines, liquid		<i>or</i> Paint related material, flammable, corrosive (including paint thinning or reducing compound)
3430	Xylenols, liquid		
3431	Nitrobenzotrifluorides, solid	3470	Paint, corrosive, flammable (including paint, lacquer, enamel, stain, shellac, varnish, polish, liquid filler and liquid lacquer base)
3432	Polychlorinated biphenyls, solid		
3434	Nitrocresols, liquid		<i>or</i> Paint related material corrosive, flammable (including paint thinning or reducing compound)
3436	Hexafluoroacetone hydrate, solid		
3437	Chlorocresols, solid	3471	Hydrogendifluorides, solution, n.o.s.
3438	alpha-Methylbenzyl alcohol, solid	3472	Crotonic acid, liquid
3439	Nitriles, solid, toxic, n.o.s.	3473	Fuel cell cartridges, containing flammable liquids <i>or</i> Fuel cell cartridges contained in equipment, containing flammable liquids
3440	Selenium compound, liquid, n.o.s.		
3441	Chlorodinitrobenzenes, solid		<i>or</i> Fuel cell cartridges packed with equipment, containing flammable liquids
3442	Dichloroanilines, solid	3474	1-Hydroxybenzotriazole monohydrate
3443	Dinitrobenzenes, solid	3475	Ethanol and gasoline mixture, with more than 10% ethanol <i>or</i> Ethanol and motor spirit mixture, with more than 10% ethanol
3444	Nicotine hydrochloride, solid		
3445	Nicotine sulphate, solid		<i>or</i> Ethanol and petrol mixture, with more than 10% ethanol
3446	Nitrotoluenes, solid		
3447	Nitroxylens, solid	3476	Fuel cell cartridges, containing water-reactive substances <i>or</i> Fuel cell cartridges contained in equipment, containing water-reactive substances
3448	Tear gas substance, solid, n.o.s.		
3449	Bromobenzyl cyanides, solid		<i>or</i> Fuel cell cartridges packed with equipment, containing water-reactive substances
3450	Diphenylchloroarsine, solid	3477	Fuel cell cartridges, containing corrosive substances <i>or</i> Fuel cell cartridges contained in equipment, containing corrosive substances
3451	Toluidines, solid		
3452	Xylidines, solid		<i>or</i> Fuel cell cartridges packed with equipment, containing corrosive substances
3453	Phosphoric acid, solid		
3454	Dinitrotoluenes, solid	3478	Fuel cell cartridges, containing liquefied flammable gas <i>or</i> Fuel cell cartridges contained in equipment, containing liquefied flammable gas
3455	Cresols, solid		
3456	Nitrosylsulphuric acid, solid		<i>or</i> Fuel cell cartridges packed with equipment, containing liquefied flammable gas
3457	Chloronitrotoluenes, solid	3479	Fuel cell cartridges, containing hydrogen in metal hydride <i>or</i> Fuel cell cartridges contained in equipment, containing hydrogen in metal hydride
3458	Nitroanisoles, solid		
3459	Nitrobromobenzene, solid		<i>or</i> Fuel cell cartridges packed with equipment, containing hydrogen in metal hydride
3460	N-Ethylbenzyltoluidines, solid		
3462	Toxins, extracted from living sources, solid, n.o.s.		
3463	Propionic acid with not less than 90% acid by mass		
3464	Organophosphorus compound, solid, toxic, n.o.s.		
3465	Organoarsenic compound, solid, n.o.s.		
3466	Metal carbonyls, solid, n.o.s.		
3467	Organometallic compound, solid, toxic, n.o.s.		
3468	Hydrogen in a metal hydride storage system <i>or</i> Hydrogen in a metal hydride storage system contained in equipment	3480	Lithium ion batteries (including lithium ion polymer batteries)

- 3481 **Lithium ion batteries contained in equipment** (including lithium ion polymer batteries)
or **Lithium ion batteries packed with equipment** (including lithium ion polymer batteries)
- 3482 **Alkali metal dispersion, flammable**
or **Alkaline earth metal dispersion, flammable**
- 3483 **Motor fuel anti-knock mixture, flammable**
- 3484 **Hydrazine aqueous solution, flammable** with more than 37% hydrazine, by mass
- 3485 **Calcium hypochlorite, dry, corrosive** with more than 39% available chlorine (8.8% available oxygen)
or **Calcium hypochlorite mixture, dry, corrosive** with more than 39% available chlorine (8.8% available oxygen)
- 3486 **Calcium hypochlorite mixture, dry, corrosive** with more than 10% but not more than 39% available chlorine
- 3487 **Calcium hypochlorite, hydrated, corrosive** with not less than 5.5% but not more than 16% water
or **Calcium hypochlorite, hydrated mixture, corrosive** with not less than 5.5% but not more than 16% water
- 3488 **Toxic by inhalation liquid, flammable, corrosive, n.o.s.** with an LC₅₀ lower than or equal to 200 mL/m³ and saturated vapour concentration greater than or equal to 500 LC₅₀
- 3489 **Toxic by inhalation liquid, flammable, corrosive, n.o.s.** with an LC₅₀ lower than or equal to 1 000 mL/m³ and saturated vapour concentration greater than or equal to 10 LC₅₀
- 3490 **Toxic by inhalation liquid, water-reactive, flammable, n.o.s.** with an LC₅₀ lower than or equal to 200 mL/m³ and saturated vapour concentration greater than or equal to 500 LC₅₀
- 3491 **Toxic by inhalation liquid, water-reactive, flammable, n.o.s.** with an LC₅₀ lower than or equal to 1 000 mL/m³ and saturated vapour concentration greater than or equal to 10 LC₅₀
- 3494 **Petroleum sour crude oil, flammable, toxic**
- 3495 **Iodine**
- 3496 **Batteries, nickel-metal hydride**
- 3497 **Krill meal**
- 3498 **Iodine monochloride, liquid**
- 3499 **Capacitor, electric double layer** (with an energy storage capacity greater than 0.3 Wh)
- 3500 **Chemical under pressure, n.o.s.**
- 3501 **Chemical under pressure, flammable, n.o.s.**
- 3502 **Chemical under pressure, toxic, n.o.s.**
- 3503 **Chemical under pressure, corrosive, n.o.s.**
- 3504 **Chemical under pressure, flammable, toxic, n.o.s.**
- 3505 **Chemical under pressure, flammable, corrosive, n.o.s.**
- 3506 **Mercury contained in manufactured articles**
- 3507 **Uranium hexafluoride, radioactive material, excepted package**, less than 0.1 kg per package, non-fissile or fissile-excepted
- 3508 **Capacitor, asymmetric** (with an energy storage capacity greater than 0.3Wh)
- 3509 **Packagings, discarded, empty, uncleaned**
- 3510 **Adsorbed gas, flammable, n.o.s.**
- 3511 **Adsorbed gas, n.o.s.**
- 3512 **Adsorbed gas, toxic, n.o.s.**
- 3513 **Adsorbed gas, oxidizing, n.o.s.**
- 3514 **Adsorbed gas, toxic, flammable, n.o.s.**
- 3515 **Adsorbed gas, toxic, oxidizing, n.o.s.**
- 3516 **Adsorbed gas, toxic, corrosive, n.o.s.**
- 3517 **Adsorbed gas, toxic, flammable, corrosive, n.o.s.**
- 3518 **Adsorbed gas, toxic, oxidizing, corrosive, n.o.s.**
- 3519 **Boron trifluoride, adsorbed**
- 3520 **Chlorine, adsorbed**
- 3521 **Silicon tetrafluoride, adsorbed**
- 3522 **Arsine, adsorbed**
- 3523 **Germane, adsorbed**
- 3524 **Phosphorus pentafluoride, adsorbed**
- 3525 **Phosphine, adsorbed**
- 3526 **Hydrogen selenide, adsorbed**
- 8000 **Consumer commodity**

Chapter 2

LIST OF N.O.S. AND GENERIC PROPER SHIPPING NAMES

Substances or articles not mentioned specifically by name in Table 3-1 must be classified in accordance with 3;1.2.7. Thus the name in Table 3-1 which most appropriately describes the substance or article should be used as the proper shipping name.

In the list that follows, all the n.o.s. entries and the main generic entries from Table 3-1 are shown, grouped by hazard class or division. Within each hazard class or division the names are placed into three groups, where appropriate, as follows:

- specific entries covering a group of substances or articles of a particular chemical or technical nature;
- pesticide entries, for Class 3 and Division 6.1;
- general entries covering a group of substances or articles having one or more general dangerous properties.

An asterisk following a name indicates that the technical name must be added, see 3;1.2.7.

THE MOST SPECIFIC APPLICABLE NAME MUST ALWAYS BE USED

<i>Class or Division</i>	<i>Subsidiary risk</i>	<i>UN No.</i>	<i>Proper shipping name</i>
CLASS 1			
1		0190	Samples, explosive* , other than initiating explosive
Division 1.1			
1.1C		0462	Articles, explosive, n.o.s.*
1.1D		0463	Articles, explosive, n.o.s.*
1.1E		0464	Articles, explosive, n.o.s.*
1.1F		0465	Articles, explosive, n.o.s.*
1.1L		0354	Articles, explosive, n.o.s.*
1.1B		0461	Components, explosive train, n.o.s.*
1.1C		0497	Propellant, liquid
1.1C		0498	Propellant, solid
1.1A		0473	Substances, explosive, n.o.s.*
1.1C		0474	Substances, explosive, n.o.s.*
1.1D		0475	Substances, explosive, n.o.s.*
1.1G		0476	Substances, explosive, n.o.s.*
1.1L		0357	Substances, explosive, n.o.s.*
Division 1.2			
1.2K	6.1	0020	Ammunition, toxic* with burster, expelling charge or propelling charge
1.2C		0466	Articles, explosive, n.o.s.*
1.2D		0467	Articles, explosive, n.o.s.*
1.2E		0468	Articles, explosive, n.o.s.*
1.2F		0469	Articles, explosive, n.o.s.*
1.2L		0355	Articles, explosive, n.o.s.*
1.2B		0382	Components, explosive train, n.o.s.*
1.2L		0248	Contrivances, water-activated* with burster, expelling charge or propelling charge
1.2L		0358	Substances, explosive, n.o.s.*
Division 1.3			
1.3K	6.1	0021	Ammunition, toxic* with burster, expelling charge or propelling charge
1.3C		0470	Articles, explosive, n.o.s.*
1.3L		0356	Articles, explosive, n.o.s.*
1.3L		0249	Contrivances, water-activated* with burster, expelling charge or propelling charge
1.3C		0132	Deflagrating metal salts of aromatic nitro-derivatives, n.o.s.
1.3C		0495	Propellant, liquid

<i>Class or Division</i>	<i>Subsidiary risk</i>	<i>UN No.</i>	<i>Proper shipping name</i>
1.3C		0499	Propellant, solid
1.3C		0477	Substances, explosive, n.o.s.*
1.3G		0478	Substances, explosive, n.o.s.*
1.3L		0359	Substances, explosive, n.o.s.*
Division 1.4			
1.4B		0350	Articles, explosive, n.o.s.*
1.4C		0351	Articles, explosive, n.o.s.*
1.4D		0352	Articles, explosive, n.o.s.*
1.4E		0471	Articles, explosive, n.o.s.*
1.4F		0472	Articles, explosive, n.o.s.*
1.4G		0353	Articles, explosive, n.o.s.*
1.4S		0349	Articles, explosive, n.o.s.*
1.4B		0383	Components, explosive train, n.o.s.*
1.4S		0384	Components, explosive train, n.o.s.*
1.4C		0501	Propellant, solid
1.4C		0479	Substances, explosive, n.o.s.*
1.4D		0480	Substances, explosive, n.o.s.*
1.4G		0485	Substances, explosive, n.o.s.*
1.4S		0481	Substances, explosive, n.o.s.*
Division 1.5			
1.5D		0482	Substances, E.V.I., n.o.s.*
1.5D		0482	Substances, explosive, very insensitive, n.o.s.*
Division 1.6			
1.6N		0486	Articles, E.E.I.
1.6N		0486	Articles, explosive, extremely insensitive
CLASS 2			
Division 2.1			
<i>Specific entries</i>			
2.1		1964	Hydrocarbon gas mixture, compressed, n.o.s.*
2.1		1965	Hydrocarbon gas mixture, liquefied, n.o.s.*
2.1		3354	Insecticide gas, flammable, n.o.s.*
<i>General entries</i>			
+ 2.1		3510	Adsorbed gas, flammable, n.o.s.*
2.1		1950	Aerosols, flammable
2.1		1954	Compressed gas, flammable, n.o.s.*
2.1		3312	Gas, refrigerated liquid, flammable, n.o.s.*
2.1		3167	Gas sample, non-pressurized, flammable, n.o.s., not refrigerated liquid
2.1		3161	Liquefied gas, flammable, n.o.s.*
2.1		3501	Chemical under pressure, flammable, n.o.s.*
2.1	8	3505	Chemical under pressure, flammable, corrosive, n.o.s.*
2.1	6.1	3504	Chemical under pressure, flammable, toxic, n.o.s.*
Division 2.2			
<i>Specific entries</i>			
2.2		1968	Insecticide gas, n.o.s.*
2.2		1078	Refrigerant gas, n.o.s.*
2.2		3500	Chemical under pressure, n.o.s.*
2.2	8	3503	Chemical under pressure, corrosive, n.o.s.*
2.2	6.1	3502	Chemical under pressure, toxic, n.o.s.*
<i>General entries</i>			
+ 2.2		3511	Adsorbed gas, n.o.s.*
+ 2.2	5.1	3513	Adsorbed gas, oxidizing, n.o.s.*
2.2		1950	Aerosols, non-flammable
2.2		1956	Compressed gas, n.o.s.*
2.2	5.1	3156	Compressed gas, oxidizing, n.o.s.*
2.2		3158	Gas, refrigerated liquid, n.o.s.*
2.2	5.1	3311	Gas, refrigerated liquid, oxidizing, n.o.s.*
2.2		3163	Liquefied gas, n.o.s.*
2.2	5.1	3157	Liquefied gas, oxidizing, n.o.s.*

Division 2.3*Specific entries*

2.3 1967
2.3 2.1 3355

General entries

		3512	Adsorbed gas, toxic, n.o.s.*
+	2.3	3514	Adsorbed gas, toxic, flammable, n.o.s.*
+	2.3	3515	Adsorbed gas, toxic, oxidizing, n.o.s.*
+	2.3	3516	Adsorbed gas, toxic, corrosive, n.o.s.*
+	2.3	3517	Adsorbed gas, toxic, flammable, corrosive, n.o.s.*
+	2.3	3518	Adsorbed gas, toxic, oxidizing, corrosive, n.o.s.*
	2.3	1950	Aerosols, flammable, containing toxic gas
	2.3	1950	Aerosols, non-flammable, containing toxic gas
	2.3	1955	Compressed gas, toxic, n.o.s.*
	2.3	3304	Compressed gas, toxic, corrosive, n.o.s.*
	2.3	1953	Compressed gas, toxic, flammable, n.o.s.*
	2.3	3305	Compressed gas, toxic, flammable, corrosive, n.o.s.*
	2.3	3303	Compressed gas, toxic, oxidizing, n.o.s.*
	2.3	3306	Compressed gas, toxic, oxidizing, corrosive, n.o.s.*
	2.3	3169	Gas sample, non-pressurized, toxic, n.o.s., not refrigerated liquid
	2.3	3168	Gas sample, non-pressurized, toxic, flammable, n.o.s., not refrigerated liquid
	2.3	3162	Liquefied gas, toxic, n.o.s.*
	2.3	3308	Liquefied gas, toxic, corrosive, n.o.s.*
	2.3	3160	Liquefied gas, toxic, flammable, n.o.s.*
	2.3	3309	Liquefied gas, toxic, flammable, corrosive, n.o.s.*
	2.3	3307	Liquefied gas, toxic, oxidizing, n.o.s.*
	2.3	3310	Liquefied gas, toxic, oxidizing, corrosive, n.o.s.*

CLASS 3*Specific entries*

	3	8	3274	Alcoholates solution, n.o.s.* , in alcohol
	3		1987	Alcohols, n.o.s.*
	3	6.1	1986	Alcohols, flammable, toxic, n.o.s.*
	3		1989	Aldehydes, n.o.s.*
	3	6.1	1988	Aldehydes, flammable, toxic, n.o.s.*
	3	8	2733	Amines, flammable, corrosive, n.o.s.*
	3	8	2985	Chlorosilanes, flammable, corrosive, n.o.s.
	3		3379	Desensitized explosive, liquid, n.o.s.*
	3		3272	Esters, n.o.s.*
	3		3271	Ethers, n.o.s.*
	3		3295	Hydrocarbons, liquid, n.o.s.
	3	6.1	2478	Isocyanate solution, flammable, toxic, n.o.s.*
	3	6.1	2478	Isocyanates, flammable, toxic, n.o.s.*
	3		1224	Ketones, liquid, n.o.s.*
	3	6.1	3248	Medicine, liquid, flammable, toxic, n.o.s.
	3		3336	Mercaptan mixture, liquid, flammable, n.o.s.*
	3		3336	Mercaptans, liquid, flammable, n.o.s.*
	3	6.1	1228	Mercaptan mixture, liquid, flammable, toxic, n.o.s.*
	3	6.1	1228	Mercaptans, liquid, flammable, toxic, n.o.s.*
	3	6.1	3273	Nitriles, flammable, toxic, n.o.s.*
	3		3357	Nitroglycerin mixture, desensitized, liquid, n.o.s. , with not more than 30% nitroglycerin, by mass
	3		3343	Nitroglycerin mixture, desensitized, liquid, flammable, n.o.s. with not more than 30% nitroglycerin, by mass
	3		1268	Petroleum distillates, n.o.s.
	3		1268	Petroleum products, n.o.s.
	3	8	2733	Polyamines, flammable, corrosive, n.o.s.*
	3		2319	Terpene hydrocarbons, n.o.s.

Pesticides

	3	6.1	2760	Arsenical pesticide, liquid, flammable, toxic* , flash point <23°C
	3	6.1	2782	Bipyridilium pesticide, liquid, flammable, toxic* , flash point <23°C
	3	6.1	2758	Carbamate pesticide, liquid, flammable, toxic* , flash point <23°C
	3	6.1	2776	Copper based pesticide, liquid, flammable, toxic* , flash point <23°C
	3	6.1	3024	Coumarin derivative pesticide, liquid, flammable, toxic* , flash point <23°C
	3	6.1	2772	Thiocarbamate pesticide, liquid, flammable, toxic* , flash point <23°C
	3	6.1	2778	Mercury based pesticide, liquid, flammable, toxic* , flash point <23°C
	3	6.1	2762	Organochlorine pesticide, liquid, flammable, toxic* , flash point <23°C
	3	6.1	2784	Organophosphorus pesticide, liquid, flammable, toxic* , flash point <23°C
	3	6.1	2787	Organotin pesticide, liquid, flammable, toxic* , flash point <23°C
	3	6.1	3021	Pesticide, liquid, flammable, toxic, n.o.s.* , flash point <23°C

3	6.1	3346	Phenoxyacetic acid derivative pesticide, liquid, flammable, toxic, flash point <23°C
3	6.1	3350	Pyrethroid pesticide, liquid flammable, toxic, flash point <23°C
3	6.1	2780	Substituted nitrophenol pesticide, liquid, flammable, toxic*, flash point <23°C
3	6.1	2764	Triazine pesticide, liquid, flammable, toxic*, flash point <23°C
<i>General entries</i>			
3		3256	Elevated temperature liquid, flammable, n.o.s.*, with flash point above 60°C, at or above its flash point
3		1993	Flammable liquid, n.o.s.*
3	8	2924	Flammable liquid, corrosive, n.o.s.*
3	6.1	1992	Flammable liquid, toxic, n.o.s.*
3	6.1 & 8	3286	Flammable liquid, toxic, corrosive, n.o.s.*

CLASS 4**Division 4.1***Specific entries*

4.1		3380	Desensitized explosive, solid, n.o.s.*
4.1		1353	Fabrics impregnated with weakly nitrated nitrocellulose, n.o.s.
4.1		1353	Fibres impregnated with weakly nitrated nitrocellulose, n.o.s.
4.1		3182	Metal hydrides, flammable, n.o.s.*
4.1		3089	Metal powder, flammable, n.o.s.
4.1		3319	Nitroglycerin mixture, desensitized, solid, n.o.s. with more than 2% but not more than 10% nitroglycerin, by mass
4.1		3344	Pentaerythrite tetranitrate mixture, desensitized, solid, n.o.s. with more than 10% but not more than 20% PETN, by mass
4.1		3344	Pentaerythritol tetranitrate mixture desensitized, solid, n.o.s.* with more than 10% but not more than 20% PETN, by mass
4.1		3344	PETN mixture desensitized, solid, n.o.s.* with more than 10% but not more than 20% PETN, by mass
4.1		3221	Self-reactive liquid type B*
4.1		3223	Self-reactive liquid type C*
4.1		3225	Self-reactive liquid type D*
4.1		3227	Self-reactive liquid type E*
4.1		3229	Self-reactive liquid type F*
4.1		3231	Self-reactive liquid type B, temperature controlled*
4.1		3233	Self-reactive liquid type C, temperature controlled*
4.1		3235	Self-reactive liquid type D, temperature controlled*
4.1		3237	Self-reactive liquid type E, temperature controlled*
4.1		3239	Self-reactive liquid type F, temperature controlled*
4.1		3222	Self-reactive solid type B*
4.1		3224	Self-reactive solid type C*
4.1		3226	Self-reactive solid type D*
4.1		3228	Self-reactive solid type E*
4.1		3230	Self-reactive solid type F*
4.1		3232	Self-reactive solid type B, temperature controlled*
4.1		3234	Self-reactive solid type C, temperature controlled*
4.1		3236	Self-reactive solid type D, temperature controlled*
4.1		3238	Self-reactive solid type E, temperature controlled*
4.1		3240	Self-reactive solid type F, temperature controlled*

General entries

4.1	8	3180	Flammable solid, corrosive, inorganic, n.o.s.*
4.1	8	2925	Flammable solid, corrosive, organic, n.o.s.*
4.1		3178	Flammable solid, inorganic, n.o.s.*
4.1		1325	Flammable solid, organic, n.o.s.*
4.1		3176	Flammable solid, organic, molten, n.o.s.*
4.1	5.1	3097	Flammable solid, oxidizing, n.o.s.*
4.1	6.1	3179	Flammable solid, toxic, inorganic, n.o.s.*
4.1	6.1	2926	Flammable solid, toxic, organic, n.o.s.*
4.1		3181	Metal salts of organic compounds, flammable, n.o.s.*
4.1		3175	Solids containing flammable liquid, n.o.s.*

Division 4.2*Specific entries*

4.2	8	3206	Alkali metal alcoholates, self-heating, corrosive, n.o.s.*
4.2		3205	Alkaline earth metal alcoholates, n.o.s.*
4.2		1373	Fabrics, animal, n.o.s., with oil
4.2		1373	Fabrics, vegetable, n.o.s., with oil
4.2		1373	Fabrics, synthetic, n.o.s., with oil
4.2		1373	Fibres, animal or vegetable or synthetic, n.o.s., with oil

4.2		2881	Metal catalyst, dry
4.2		1378	Metal catalyst, wetted with a visible excess of liquid
4.2		3189	Metal powder, self-heating, n.o.s.*
4.2		3313	Organic pigments, self-heating
4.2		3392	Organometallic substance, liquid, pyrophoric
4.2	4.3	3394	Organometallic substance, liquid, pyrophoric, water-reactive
4.2		3391	Organometallic substance, solid, pyrophoric
4.2	4.3	3393	Organometallic substance, solid, pyrophoric, water-reactive
4.2		3400	Organometallic substance, solid, self-heating
4.2		2006	Plastics, nitrocellulose-based, self-heating, n.o.s.* or Pyrophoric alloy, n.o.s.*
4.2		1383	Pyrophoric alloy, n.o.s.*
4.2		1383	Pyrophoric metal, n.o.s.*
4.2		3342	Xanthates
<i>General entries</i>			
4.2		3194	Pyrophoric liquid, inorganic, n.o.s.*
4.2		2845	Pyrophoric liquid, organic, n.o.s.*
4.2		3200	Pyrophoric solid, inorganic, n.o.s.*
4.2		2846	Pyrophoric solid, organic, n.o.s.*
4.2	8	3188	Self-heating liquid, corrosive, inorganic, n.o.s.*
4.2	8	3185	Self-heating liquid, corrosive, organic, n.o.s.*
4.2		3186	Self-heating liquid, inorganic, n.o.s.*
4.2		3183	Self-heating liquid, organic, n.o.s.*
4.2	6.1	3187	Self-heating liquid, toxic, inorganic, n.o.s.*
4.2	6.1	3184	Self-heating liquid, toxic, organic, n.o.s.*
4.2	8	3192	Self-heating solid, corrosive, inorganic, n.o.s.*
4.2	8	3126	Self-heating solid, corrosive, organic, n.o.s.*
4.2		3190	Self-heating solid, inorganic, n.o.s.*
4.2		3088	Self-heating solid, organic, n.o.s.*
4.2	5.1	3127	Self-heating solid, oxidizing, n.o.s.*
4.2	6.1	3191	Self-heating solid, toxic, inorganic, n.o.s.*
4.2	6.1	3128	Self-heating solid, toxic, organic, n.o.s.*
Division 4.3			
<i>Specific entries</i>			
4.3		1421	Alkali metal alloy, liquid, n.o.s.
4.3		1389	Alkali metal amalgam, liquid
4.3		3401	Alkali metal amalgam, solid
4.3		1390	Alkali metal amides
4.3		1391	Alkali metal dispersion
4.3		1393	Alkaline earth metal alloy, n.o.s.
4.3		1392	Alkaline earth metal amalgam, liquid
4.3		3402	Alkaline earth metal amalgam, solid
4.3		1391	Alkaline earth metal dispersion
4.3	3 & 8	2988	Chlorosilanes, water-reactive, flammable, corrosive, n.o.s.
4.3		1409	Metal hydrides, water-reactive, n.o.s.*
4.3		3208	Metallic substance, water-reactive, n.o.s.*
4.3	4.2	3209	Metallic substance, water-reactive, self-heating, n.o.s.*
4.3		3398	Organometallic substance, liquid, water-reactive
4.3		3399	Organometallic substance, liquid, water-reactive, flammable
4.3		3395	Organometallic substance, solid, water-reactive
4.3	4.1	3396	Organometallic substance, solid, water-reactive, flammable
4.3	4.2	3397	Organometallic substance, solid, water-reactive, self-heating
<i>General entries</i>			
4.3		3148	Water-reactive liquid, n.o.s.*
4.3	8	3129	Water-reactive liquid, corrosive, n.o.s.*
4.3	6.1	3130	Water-reactive liquid, toxic, n.o.s.*
4.3		2813	Water-reactive solid, n.o.s.*
4.3	8	3131	Water-reactive solid, corrosive, n.o.s.*
4.3	4.1	3132	Water-reactive solid, flammable, n.o.s.*
4.3	5.1	3133	Water-reactive solid, oxidizing, n.o.s.*
4.3	4.2	3135	Water-reactive solid, self-heating, n.o.s.*
4.3	6.1	3134	Water-reactive solid, toxic, n.o.s.*

CLASS 5**Division 5.1***Specific entries*

5.1		1450	Bromates, inorganic, n.o.s.*
5.1		3213	Bromates, inorganic, aqueous solution, n.o.s.*
5.1		1461	Chlorates, inorganic, n.o.s.*
5.1		3210	Chlorates, inorganic, aqueous solution, n.o.s.*
5.1		1462	Chlorites, inorganic, n.o.s.*
5.1		3212	Hypochlorites, inorganic, n.o.s.*
5.1		1477	Nitrates, inorganic, n.o.s.
5.1		3218	Nitrates, inorganic, aqueous solution, n.o.s.
5.1		2627	Nitrites, inorganic, n.o.s.*
5.1		3219	Nitrites, inorganic, aqueous solution, n.o.s.*
5.1		1481	Perchlorates, inorganic, n.o.s.
5.1		3211	Perchlorates, inorganic, aqueous solution, n.o.s.
5.1		1482	Permanganates, inorganic, n.o.s.*
5.1		3214	Permanganates, inorganic, aqueous solution, n.o.s.*
5.1		1483	Peroxides, inorganic, n.o.s.
5.1		3215	Persulphates, inorganic, n.o.s.
5.1		3216	Persulphates, inorganic, aqueous solution, n.o.s.

General entries

5.1		3139	Oxidizing liquid, n.o.s.*
5.1	8	3098	Oxidizing liquid, corrosive, n.o.s.*
5.1	6.1	3099	Oxidizing liquid, toxic, n.o.s.*
5.1		1479	Oxidizing solid, n.o.s.*
5.1	8	3085	Oxidizing solid, corrosive, n.o.s.*
5.1	4.1	3137	Oxidizing solid, flammable, n.o.s.*
5.1	4.2	3100	Oxidizing solid, self-heating, n.o.s.*
5.1	6.1	3087	Oxidizing solid, toxic, n.o.s.*
5.1	4.3	3121	Oxidizing solid, water-reactive, n.o.s.*

Division 5.2*Specific entries*

5.2		3101	Organic peroxide type B, liquid*
5.2		3111	Organic peroxide type B, liquid, temperature controlled*
5.2		3102	Organic peroxide type B, solid*
5.2		3112	Organic peroxide type B, solid, temperature controlled*
5.2		3103	Organic peroxide type C, liquid*
5.2		3113	Organic peroxide type C, liquid, temperature controlled*
5.2		3104	Organic peroxide type C, solid*
5.2		3114	Organic peroxide type C, solid, temperature controlled*
5.2		3105	Organic peroxide type D, liquid*
5.2		3115	Organic peroxide type D, liquid, temperature controlled*
5.2		3106	Organic peroxide type D, solid*
5.2		3116	Organic peroxide type D, solid, temperature controlled*
5.2		3107	Organic peroxide type E, liquid*
5.2		3117	Organic peroxide type E, liquid, temperature controlled*
5.2		3108	Organic peroxide type E, solid*
5.2		3118	Organic peroxide type E, solid, temperature controlled*
5.2		3109	Organic peroxide type F, liquid*
5.2		3119	Organic peroxide type F, liquid, temperature controlled*
5.2		3110	Organic peroxide type F, solid*
5.2		3120	Organic peroxide type F, solid, temperature controlled*

CLASS 6**Division 6.1***Specific entries*

6.1		3140	Alkaloid salts, liquid, n.o.s.*
6.1		3140	Alkaloids, liquid, n.o.s.*
6.1		1544	Alkaloid salts, solid, n.o.s.*
6.1		1544	Alkaloids, solid, n.o.s.*
6.1		3141	Antimony compound, inorganic, liquid, n.o.s.*
6.1		1549	Antimony compound, inorganic, solid, n.o.s.*
6.1		1556	Arsenic compound, liquid, n.o.s.*
6.1		1557	Arsenic compound, solid, n.o.s.*
6.1		1564	Barium compound, n.o.s.*
6.1		1566	Beryllium compound, n.o.s.*
6.1		2570	Cadmium compound

6.1	8	3277	Chloroformates, toxic, corrosive, n.o.s.*
6.1	3 & 8	2742	Chloroformates, toxic, corrosive, flammable, n.o.s.*
6.1	8	3361	Chlorosilanes, toxic, corrosive, n.o.s.*
6.1	3 & 8	3362	Chlorosilanes, toxic, corrosive, flammable, n.o.s.*
6.1		1583	Chloropicrin mixture, n.o.s.*
6.1		1588	Cyanides, inorganic, solid, n.o.s.*
6.1		1935	Cyanide solution, n.o.s.*
6.1		3142	Disinfectant, liquid, toxic, n.o.s.*
6.1		1601	Disinfectant, solid, toxic, n.o.s.*
6.1		1602	Dye intermediate, liquid, toxic, n.o.s.*
6.1		1602	Dye, liquid, toxic, n.o.s.*
6.1		3143	Dye intermediate, solid, toxic, n.o.s.*
6.1		3143	Dye, solid, toxic, n.o.s.*
6.1		2856	Fluorosilicates, n.o.s.*
6.1		2206	Isocyanate solution, toxic, n.o.s.*
6.1		2206	Isocyanates, toxic, n.o.s.*
6.1	3	3080	Isocyanate solution, toxic, flammable, n.o.s.*
6.1	3	3080	Isocyanates, toxic, flammable, n.o.s.*
6.1		2291	Lead compound, soluble, n.o.s.*
6.1		1851	Medicine, liquid, toxic, n.o.s.
6.1		3249	Medicine, solid, toxic, n.o.s.
6.1	3	3071	Mercaptan mixture, liquid, toxic, flammable, n.o.s.*
6.1	3	3071	Mercaptans, liquid, toxic, flammable, n.o.s.*
6.1		2024	Mercury compound, liquid, n.o.s.*
6.1		2025	Mercury compound, solid, n.o.s.*
6.1		3281	Metal carbonyls, liquid, n.o.s.*
6.1		3466	Metal carbonyls, solid, n.o.s.*
6.1		3144	Nicotine compound, liquid, n.o.s.*
6.1		1655	Nicotine compound, solid, n.o.s.*
6.1		3144	Nicotine preparation, liquid, n.o.s.*
6.1		1655	Nicotine preparation, solid, n.o.s.*
6.1		3276	Nitriles, liquid, toxic, n.o.s.*
6.1	3	3275	Nitriles, toxic, flammable, n.o.s.*
6.1		3439	Nitriles, solid, toxic, n.o.s.*
6.1		3280	Organoarsenic compound, liquid, n.o.s.*
6.1		3465	Organoarsenic compound, solid, n.o.s.*
6.1		3282	Organometallic compound, liquid, toxic, n.o.s.*
6.1		3467	Organometallic compound, solid, toxic, n.o.s.*
6.1		3278	Organophosphorus compound, liquid, toxic, n.o.s.*
6.1	3	3279	Organophosphorus compound, toxic, flammable, n.o.s.*
6.1		3464	Organophosphorus compound, solid, toxic, n.o.s.*
6.1		2788	Organotin compound, liquid, n.o.s.
6.1		3146	Organotin compound, solid, n.o.s.
6.1		2026	Phenylmercuric compound, n.o.s.*
6.1		3440	Selenium compound, liquid, n.o.s.*
6.1		3283	Selenium compound, solid, n.o.s.*
6.1		1693	Tear gas substance, liquid, n.o.s.*
6.1		3448	Tear gas substance, solid, n.o.s.*
6.1		3284	Tellurium compound, n.o.s.*
6.1		1707	Thallium compound, n.o.s.
6.1		3285	Vanadium compound, n.o.s.*
<i>Pesticides</i>			
<i>(a) Solid</i>			
6.1		2759	Arsenical pesticide, solid, toxic*
6.1		2781	Bipyridilium pesticide, solid, toxic*
6.1		2757	Carbamate pesticide, solid, toxic*
6.1		2775	Copper based pesticide, solid, toxic*
6.1		3027	Coumarin derivative pesticide, solid, toxic*
6.1		2771	Thiocarbamate pesticide, solid, toxic*
6.1		2777	Mercury based pesticide, solid, toxic*
6.1		2761	Organochlorine pesticide, solid, toxic*
6.1		2783	Organophosphorus pesticide, solid, toxic*
6.1		2786	Organotin pesticide, solid, toxic*
6.1		2588	Pesticide, solid, toxic, n.o.s.*
6.1		3345	Phenoxyacetic acid derivative pesticide, solid, toxic
6.1		3349	Pyrethroid pesticide, solid, toxic
6.1		2779	Substituted nitrophenol pesticide, solid, toxic*
6.1		2763	Triazine pesticide, solid, toxic*
<i>(b) Liquid</i>			
6.1		2994	Arsenical pesticide, liquid, toxic*
6.1	3	2993	Arsenical pesticide, liquid, toxic, flammable*, flash point $\geq 23^{\circ}\text{C}$
6.1		3016	Bipyridilium pesticide, liquid, toxic*

6.1	3	3015	Bipyridilium pesticide, liquid, toxic, flammable* , flash point $\geq 23^{\circ}\text{C}$
6.1		2992	Carbamate pesticide, liquid, toxic*
6.1	3	2991	Carbamate pesticide, liquid, toxic, flammable* , flash point $\geq 23^{\circ}\text{C}$
6.1		3010	Copper based pesticide, liquid, toxic*
6.1	3	3009	Copper based pesticide, liquid, toxic, flammable* , flash point $\geq 23^{\circ}\text{C}$
6.1		3026	Coumarin derivative pesticide, liquid, toxic*
6.1	3	3025	Coumarin derivative pesticide, liquid, toxic, flammable* , flash point $\geq 23^{\circ}\text{C}$
6.1		3012	Mercury based pesticide, liquid, toxic*
6.1	3	3011	Mercury based pesticide, liquid, toxic, flammable* , flash point $\geq 23^{\circ}\text{C}$
6.1		2996	Organochlorine pesticide, liquid, toxic*
6.1	3	2995	Organochlorine pesticide, liquid, toxic, flammable* , flash point $\geq 23^{\circ}\text{C}$
6.1		3018	Organophosphorus pesticide, liquid, toxic*
6.1	3	3017	Organophosphorus pesticide, liquid, toxic, flammable* , flash point $\geq 23^{\circ}\text{C}$
6.1		3020	Organotin pesticide, liquid, toxic*
6.1	3	3019	Organotin pesticide, liquid, toxic, flammable* , flash point $\geq 23^{\circ}\text{C}$
6.1		2902	Pesticide, liquid, toxic, n.o.s.*
6.1	3	2903	Pesticide, liquid, toxic, flammable, n.o.s.* , flash point $\geq 23^{\circ}\text{C}$
6.1		3348	Phenoxyacetic acid derivative pesticide, liquid, toxic*
6.1	3	3347	Phenoxyacetic acid derivative pesticide, liquid, toxic, flammable , flash point $\geq 23^{\circ}\text{C}$
6.1	3	3352	Pyrethroid pesticide, liquid, toxic
6.1	3	3351	Pyrethroid pesticide, liquid, toxic, flammable , flash point $\geq 23^{\circ}\text{C}$
6.1		3014	Substituted nitrophenol pesticide, liquid, toxic*
6.1	3	3013	Substituted nitrophenol pesticide, liquid, toxic, flammable* , flash point $\geq 23^{\circ}\text{C}$
6.1		3006	Thiocarbamate pesticide, liquid, toxic*
6.1	3	3005	Thiocarbamate pesticide, liquid, toxic, flammable* , flash point $\geq 23^{\circ}\text{C}$
6.1		2998	Triazine pesticide, liquid, toxic*
6.1	3	2997	Triazine pesticide, liquid, toxic, flammable* , flash point $\geq 23^{\circ}\text{C}$
<i>General entries</i>			
6.1		3315	Chemical sample, toxic
6.1		3243	Solids containing toxic liquid, n.o.s.*
6.1	8	3389	Toxic by inhalation liquid, corrosive, n.o.s.* with an LC_{50} lower than or equal to 200 ml/m^3 and saturated vapour concentration greater than or equal to 500 LC_{50}
6.1	8	3390	Toxic by inhalation liquid, corrosive, n.o.s.* with an LC_{50} lower than or equal to $1\ 000 \text{ ml/m}^3$ and saturated vapour concentration greater than or equal to 10 LC_{50}
6.1	3	3383	Toxic by inhalation liquid, flammable, n.o.s.* with an LC_{50} lower than or equal to 200 ml/m^3 and saturated vapour concentration greater than or equal to 500 LC_{50}
6.1	3	3384	Toxic by inhalation liquid, flammable, n.o.s.* with an LC_{50} lower than or equal to $1\ 000 \text{ ml/m}^3$ and saturated vapour concentration greater than or equal to 10 LC_{50}
6.1	3 & 8	3488	Toxic by inhalation liquid, flammable, corrosive, n.o.s.* with an LC_{50} lower than or equal to 200 ml/m^3 and saturated vapour concentration greater than or equal to 500 LC_{50}
6.1	3 & 8	3489	Toxic by inhalation liquid, flammable, corrosive, n.o.s.* with an LC_{50} lower than or equal to $1\ 000 \text{ ml/m}^3$ and saturated vapour concentration greater than or equal to 10 LC_{50}
6.1		3381	Toxic by inhalation liquid, n.o.s.* with an LC_{50} lower than or equal to 200 ml/m^3 and saturated vapour concentration greater than or equal to 500 LC_{50}
6.1		3382	Toxic by inhalation liquid, n.o.s.* with an LC_{50} lower than or equal to $1\ 000 \text{ ml/m}^3$ and saturated vapour concentration greater than or equal to 10 LC_{50}
6.1	5.1	3387	Toxic by inhalation liquid, oxidizing, n.o.s.* with an LC_{50} lower than or equal to 200 ml/m^3 and saturated vapour concentration greater than or equal to 500 LC_{50}
6.1	5.1	3388	Toxic by inhalation liquid, oxidizing, n.o.s.* with an LC_{50} lower than or equal to $1\ 000 \text{ ml/m}^3$ and saturated vapour concentration greater than or equal to 10 LC_{50}
6.1	3 & 4.3	3490	Toxic by inhalation liquid, water-reactive, flammable, n.o.s.* with an LC_{50} lower than or equal to 200 ml/m^3 and saturated vapour concentration greater than or equal to 500 LC_{50}
6.1	3 & 4.3	3491	Toxic by inhalation liquid, water-reactive, flammable, n.o.s.* with an LC_{50} lower than or equal to $1\ 000 \text{ ml/m}^3$ and saturated vapour concentration greater than or equal to 10 LC_{50}
6.1	4.3	3385	Toxic by inhalation liquid, water-reactive, n.o.s.* with an LC_{50} lower than or equal to 200 ml/m^3 and saturated vapour concentration greater than or equal to 500 LC_{50}
6.1	4.3	3386	Toxic by inhalation liquid, water-reactive, n.o.s.* with an LC_{50} lower than or equal to $1\ 000 \text{ ml/m}^3$ and saturated vapour concentration greater than or equal to 10 LC_{50}
6.1	8	3289	Toxic liquid, corrosive, inorganic, n.o.s.*

6.1	8	2927	Toxic liquid, corrosive, organic, n.o.s.*
6.1	3	2929	Toxic liquid, flammable, organic, n.o.s.*
6.1		3287	Toxic liquid, inorganic, n.o.s.*
6.1		2810	Toxic liquid, organic, n.o.s.*
6.1	5.1	3122	Toxic liquid, oxidizing, n.o.s.*
6.1	4.3	3123	Toxic liquid, water-reactive, n.o.s.*
6.1	8	3290	Toxic solid, corrosive, inorganic, n.o.s.*
6.1	8	2928	Toxic solid, corrosive, organic, n.o.s.*
6.1	4.1	2930	Toxic solid, flammable, organic, n.o.s.*
6.1		3288	Toxic solid, inorganic, n.o.s.*
6.1		2811	Toxic solid, organic, n.o.s.*
6.1	5.1	3086	Toxic solid, oxidizing, n.o.s.*
6.1	4.2	3124	Toxic solid, self-heating, n.o.s.*
6.1	4.3	3125	Toxic solid, water-reactive, n.o.s.*
6.1		3172	Toxins, extracted from living sources, liquid, n.o.s.*
6.1		3462	Toxins, extracted from living sources, solid, n.o.s.*

Division 6.2*Specific entries*

6.2		3373	Biological substance, Category B
6.2		3291	Biomedical waste, n.o.s.
6.2		3291	Clinical waste, unspecified, n.o.s.
6.2		3291	Medical waste, n.o.s.
6.2		3291	Regulated medical waste, n.o.s.

General entries

6.2		2900	Infectious substance, affecting animals* only
6.2		2814	Infectious substance, affecting humans*

CLASS 7*General entries*

7		2908	Radioactive material, excepted package — empty packaging
7		2909	Radioactive material, excepted package — articles manufactured from natural uranium or depleted uranium or natural thorium
7		2910	Radioactive material, excepted package — limited quantity of material
7		2911	Radioactive material, excepted package — instruments or articles
7		2912	Radioactive material, low specific activity (LSA-I), non-fissile or fissile excepted
7		2913	Radioactive material, surface contaminated objects (SCO-I or SCO-II), non-fissile or fissile excepted
7		2915	Radioactive material, Type A package, non-special form, non-fissile or fissile excepted
7		2916	Radioactive material, Type B(U) package, non-fissile or fissile excepted
7		2917	Radioactive material, Type B(M) package, non-fissile or fissile excepted
7		2919	Radioactive material, transported under special arrangement, non-fissile or fissile excepted
7		3321	Radioactive material, low specific activity (LSA-II), non-fissile or fissile excepted
7		3322	Radioactive material, low specific activity (LSA-III), non-fissile or fissile excepted
7		3323	Radioactive material, Type C package, non-fissile or fissile excepted
7		3324	Radioactive material, low specific activity (LSA-II) fissile
7		3325	Radioactive material, low specific activity (LSA-III) fissile
7		3326	Radioactive material, surface contaminated objects (SCO-I or SCO-II), fissile
7		3327	Radioactive material, Type A package, fissile, non-special form
7		3328	Radioactive material, Type B(U) package, fissile
7		3329	Radioactive material, Type B(M) package, fissile
7		3330	Radioactive material, Type C package, fissile
7		3331	Radioactive material, transported under special arrangement, fissile
7		3332	Radioactive material, Type A package, special form, non-fissile or fissile excepted
7		3333	Radioactive material, Type A package, special form, fissile

CLASS 8*Specific entries*

8		3145	Alkylphenols, liquid, n.o.s. (including C ₂ -C ₁₂ homologues)
8		2430	Alkylphenols, solid, n.o.s. (including C ₂ -C ₁₂ homologues)
8		2735	Amines, liquid, corrosive, n.o.s.*

8	3	2734	Amines, liquid, corrosive, flammable, n.o.s.*
8		3259	Amines, solid, corrosive, n.o.s.*
8		2837	Bisulphates, aqueous solution
8		2693	Bisulphites, aqueous solution, n.o.s.
8		1719	Caustic alkali liquid, n.o.s.*
8		2987	Chlorosilanes, corrosive, n.o.s.
8	3	2986	Chlorosilanes, corrosive, flammable, n.o.s.
8		1903	Disinfectant, liquid, corrosive, n.o.s.*
8		2801	Dye intermediate, liquid, corrosive, n.o.s.*
8		3147	Dye intermediate, solid, corrosive, n.o.s.*
8		2801	Dye, liquid, corrosive, n.o.s.*
8		3147	Dye, solid, corrosive, n.o.s.*
8		1740	Hydrogendifluorides, solid, n.o.s.
8		3471	Hydrogendifluorides, solution, n.o.s.
8		2735	Polyamines, liquid, corrosive, n.o.s.*
8	3	2734	Polyamines, liquid, corrosive, flammable, n.o.s.*
8		3259	Polyamines, solid, corrosive, n.o.s.*
<i>General entries</i>			
8		1760	Corrosive liquid, n.o.s.*
8		3264	Corrosive liquid, acidic, inorganic, n.o.s.*
8		3265	Corrosive liquid, acidic, organic, n.o.s.*
8		3266	Corrosive liquid, basic, inorganic, n.o.s.*
8		3267	Corrosive liquid, basic, organic, n.o.s.*
8	3	2920	Corrosive liquid, flammable, n.o.s.*
8	5.1	3093	Corrosive liquid, oxidizing, n.o.s.*
8	4.2	3301	Corrosive liquid, self-heating, n.o.s.*
8	6.1	2922	Corrosive liquid, toxic, n.o.s.*
8	4.3	3094	Corrosive liquid, water-reactive, n.o.s.*
8		1759	Corrosive solid, n.o.s.*
8		3260	Corrosive solid, acidic, inorganic, n.o.s.*
8		3261	Corrosive solid, acidic, organic, n.o.s.*
8		3262	Corrosive solid, basic, inorganic, n.o.s.*
8		3263	Corrosive solid, basic, organic, n.o.s.*
8	4.1	2921	Corrosive solid, flammable, n.o.s.*
8	5.1	3084	Corrosive solid, oxidizing, n.o.s.*
8	4.2	3095	Corrosive solid, self-heating, n.o.s.*
8	6.1	2923	Corrosive solid, toxic, n.o.s.*
8	4.3	3096	Corrosive solid, water-reactive, n.o.s.*
8		3244	Solids containing corrosive liquid, n.o.s.*

CLASS 9

<i>General entries</i>			
+	9	2212	Asbestos, amphibole*
	9	3334	Aviation regulated liquid, n.o.s.*
	9	3335	Aviation regulated solid, n.o.s.*
	9	3257	Elevated temperature liquid, n.o.s.*
	9	3258	Elevated temperature solid, n.o.s.*
	9	3082	Environmentally hazardous substance, liquid, n.o.s.*
	9	3077	Environmentally hazardous substance, solid, n.o.s.*
	9	3245	Genetically modified micro-organisms
	9	3245	Genetically modified organisms

Attachment 2

GLOSSARY OF TERMS

Caution: These explanations are only for information. They must not be relied upon for purposes of hazard classification and may not necessarily reflect the information provided to the United Nations at the time the UN numbers were assigned.

Glossary of terms

<i>Term and explanation</i>	<i>UN Number(s), when relevant</i>
v	
AIRCRAFT ENGINES. Generic term for engines powering flying craft fuelled by flammable liquid (jet-fuel, petrol, kerosene, etc.) which applies to piston designs, turbine designs and includes auxiliary power units (APU).	3166
ALUMINIUM PROCESSING BY-PRODUCTS. The material, consisting of skimmings of virgin aluminium, rising to the surface of impure molten aluminium metal.	3170
ALUMINIUM POWDER. The uncoated powder may evolve hydrogen in contact with water, and finely divided dust may be ignited by naked lights or sparks. Coated aluminium powders which have been treated with oils or wax for printing or paint purposes are generally not dangerous.	1309, 1396
AMMUNITION. Generic term related mainly to articles of military application consisting of all kinds of bombs, grenades, rockets, mines, projectiles and other similar devices or contrivances.	—
AMMUNITION, ILLUMINATING with or without burster, expelling charge or propelling charge. Ammunition designed to produce a single source of intense light for lighting up an area. The term includes illuminating cartridges, grenades and projectiles; and illuminating and target identification bombs. The term excludes the following articles which are listed separately: CARTRIDGES, SIGNAL; SIGNAL DEVICES, HAND; SIGNALS, DISTRESS; FLARES, AERIAL; and FLARES, SURFACE.	0171, 0254, 0297
AMMUNITION, INCENDIARY. Ammunition containing incendiary substance which may be a solid, liquid or gel including white phosphorus. Except when the composition is an explosive per se, it also contains one or more of the following: a propelling charge with primer and igniter charge; a fuze with burster or expelling charge. The term includes: AMMUNITION, INCENDIARY, liquid or gel, with burster, expelling charge or propelling charge; AMMUNITION, INCENDIARY, with or without burster, expelling charge or propelling charge; AMMUNITION, INCENDIARY, WHITE PHOSPHORUS, with burster, expelling charge or propelling charge.	0009, 0010, 0243, 0244, 0247, 0300
AMMUNITION, PRACTICE. Ammunition without a main bursting charge, containing a burster or expelling charge. Normally it also contains a fuze and a propelling charge. The term excludes the following articles which are listed separately: GRENADES, PRACTICE.	0362, 0488
AMMUNITION, PROOF. Ammunition containing pyrotechnic substance used to test the performance or strength of new ammunition, weapon components or assemblies.	0363
AMMUNITION, SMOKE. Ammunition containing smoke-producing substance such as chlorosulphonic acid mixture, titanium tetrachloride or white phosphorus; or smoke-producing pyrotechnic composition based on hexachloroethane or red phosphorus. Except when the substance is an explosive per se, the ammunition also contains one or more of the following: a propelling charge with primer and igniter charge; a fuze with burster or expelling charge. The term includes 'grenades, smoke' but excludes SIGNALS, SMOKE which are listed separately. The term includes: AMMUNITION, SMOKE, with or without burster, expelling charge or propelling charge; AMMUNITION, SMOKE, WHITE PHOSPHORUS, with burster, expelling charge or propelling charge.	0015, 0016, 0245, 0246, 0303
AMMUNITION, TEAR-PRODUCING with burster, expelling charge or propelling charge. Ammunition containing tear-producing substance. It also contains one or more of the following: a pyrotechnic substance; a propelling charge with primer and igniter charge; a fuze with burster or expelling charge.	0018, 0019, 0301
AMMUNITION, TOXIC, with burster, expelling charge or propelling charge. Ammunition containing toxic agent. It also contains one or more of the following: a pyrotechnic substance; a propelling charge with primer and igniter charge; a fuze with burster or expelling charge.	0020, 0021
ARSENICAL DUST. Smelter dust which contains large proportions of arsenic. These dusts are hazardous due to their toxic characteristics.	1562

<i>Term and explanation</i>	<i>UN Number(s), when relevant</i>
ARTICLES, EXPLOSIVE, EXTREMELY INSENSITIVE (ARTICLES, EEI). Articles that contain only extremely insensitive substances and which demonstrate a negligible probability of accidental initiation or propagation (under normal conditions of transport).	0486
<i>Note.— An extremely insensitive substance is a substance which although capable of sustaining a detonation has demonstrated through tests that it is so insensitive that there is very little probability of accidental initiation.</i>	
ARTICLES, PYROPHORIC. Articles which contain a pyrophoric substance capable of spontaneous ignition when exposed to air and an explosive substance or component. The term excludes articles containing white phosphorus.	0380
ARTICLES, PYROTECHNIC for technical purposes. Articles which contain pyrotechnic substances and are used for technical purposes such as heat generation, gas generation, theatrical effects, etc. The term excludes the following articles which are listed separately: all ammunition; CARTRIDGES, SIGNAL; CUTTERS, CABLE, EXPLOSIVE; FIREWORKS; FLARES, AERIAL; FLARES, SURFACE; RELEASE DEVICES, EXPLOSIVE; RIVETS, EXPLOSIVE; SIGNAL DEVICES, HAND; SIGNALS, DISTRESS; SIGNALS, RAILWAY TRACK, EXPLOSIVE; SIGNALS, SMOKE.	0428, 0429, 0430, 0431, 0432
≠ ASBESTOS. Asbestos is a generic name for naturally occurring mineral silicate fibres of the Serpentine and Amphibole series. In the Serpentine series is Chrysotile. In the Amphibole series are Actinolite, Amosite, Anthophyllite, Crocidolite and Tremolite. All types of asbestos can be hazardous to health, Amphibole asbestos being the more dangerous type.	2212, 2590
AUXILIARY EXPLOSIVE COMPONENT, isolated. An "isolated auxiliary explosive component" is a small device that explosively performs an operation related to the article's functioning, other than its main explosive loads' performance. Functioning of the component does not cause any reaction of the main explosive loads contained within the article.	
BATTERIES, CONTAINING SODIUM. Articles consisting of a series of CELLS, CONTAINING SODIUM that are secured within, and fully enclosed by a metal casing so constructed and closed as to prevent the release of dangerous goods under normal conditions of transport. Although designed and intended to provide a source of electrical energy, these batteries are electrically inert at any temperature at which the sodium contained in the battery is in a solid state.	3292
BATTERIES, DRY, CONTAINING POTASSIUM HYDROXIDE, SOLID. Storage batteries filled with potassium hydroxide, solid which are shipped from the factory in their original dry state and filled with the dry alkali. Water would be added to the battery before first being used.	3028
BATTERIES, WET, FILLED WITH ACID OR ALKALI. A series of metal plates immersed in an electrolyte, which is usually dilute sulphuric acid, but for a certain type of battery the electrolyte is a solution of potassium hydroxide. Both of these electrolytes are corrosive liquids. The casing for the acid containing batteries is commonly plastic. Storage batteries of either of these types, when containing electrolyte, are classed as corrosive liquids. Storage batteries in transit may cause damage by leakage of the electrolyte or may produce fire by accidental short-circuiting of the terminals.	2794, 2795
BLACK POWDER (GUNPOWDER). Substance consisting of an intimate mixture of charcoal or other carbon and either potassium nitrate or sodium nitrate, with or without sulphur. It may be meal, granular, compressed or pelletized.	0027, 0028
BOMBS. Explosive articles which are dropped from aircraft. They may contain a flammable liquid with bursting charge, a photo-flash composition or a bursting charge. The term excludes torpedoes (aerial) and includes: BOMBS, PHOTO-FLASH; BOMBS with bursting charge; BOMBS WITH FLAMMABLE LIQUID, with bursting charge.	0033, 0034, 0035, 0037, 0038, 0039, 0291, 0299, 0399, 0400
BOOSTERS. Articles consisting of a charge of detonating explosive with or without means of initiation. They are used to increase the initiating power of detonators or detonating cord.	0042, 0225, 0268, 0283
BURSTERS, explosive. Articles consisting of a small charge of explosive used to open projectiles, or other ammunition in order to disperse their contents.	0043
CAPS, TOY (AMORCES). Articles consisting of a small quantity of an explosive substance between two strips or discs of paper or contained in a plastic cup or covered by varnishing or other means.	—
CARTRIDGES ACTUATING FOR FIRE EXTINGUISHER. Contrivances containing a small explosive charge with a primer, the functioning of which ruptures a metal piece (for example, a bursting disc) and thereby actuates a fire extinguisher.	—
CARTRIDGES, BLANK. Articles which consist of a cartridge case with a centre or rim fire primer and a confined charge of smokeless or black powder but no projectile. Used for training, saluting or in starter pistols, etc.	0014, 0326, 0327, 0338, 0413

<i>Term and explanation</i>	<i>UN Number(s), when relevant</i>
CARTRIDGES, FLASH. Articles consisting of a casing, a primer and flash powder, all assembled in one piece ready for firing.	0049, 0050
CARTRIDGES FOR WEAPONS.	0005, 0006, 0007, 0014, 0321, 0326, 0327, 0338, 0348, 0412, 0413
1) Fixed (assembled) or semi-fixed (partially-assembled) ammunition designed to be fired from weapons. Each cartridge includes all the components necessary to function the weapon once. The name and description should be used for small arms cartridges that cannot be described as 'cartridges, small arms'. Separate loading ammunition is included under this name and description when the propelling charge and projectile are packed together (see also 'Cartridges, blank').	
2) Incendiary, smoke, toxic and tear-producing cartridges are described in this Attachment under 'ammunition, incendiary' etc.	
CARTRIDGES FOR WEAPONS, INERT PROJECTILE. Ammunition consisting of a projectile without bursting charge but with a propelling charge. The presence of a tracer can be disregarded for classification purposes provided that the predominant hazard is that of the propelling charge.	0012, 0328, 0339, 0417
CARTRIDGES, OIL WELL. Articles consisting of a casing of thin fibre, metal or other material containing only propellant which projects a hardened projectile. The term excludes the following articles which are listed separately: CHARGES, SHAPED.	0277, 0278
CARTRIDGES, POWER DEVICE. Articles designed to accomplish mechanical actions. They consist of a casing with a charge of deflagrating explosive and a means of ignition. The gaseous products of the deflagration produce inflation, linear or rotary motion or activate diaphragms, valves or switches or project fastening devices or extinguishing agents.	0275, 0276, 0323, 0381
CARTRIDGES, SIGNAL. Articles designed to fire coloured flares or other signals from signal pistols, etc.	0054, 0312, 0405
CARTRIDGES, SMALL ARMS. Ammunition consisting of a cartridge case fitted with a centre or rim fire primer and containing both a propelling charge and solid projectile(s). They are designed to be fired in weapons of calibre not larger than 19.1 mm. Shot-gun cartridges of any calibre are included in this definition. The term excludes: CARTRIDGES, SMALL ARMS, BLANK listed separately; and some small arms cartridges which are listed under CARTRIDGES FOR WEAPONS, INERT PROJECTILE.	0012, 0328, 0339, 0417
CASES, CARTRIDGE, EMPTY, WITH PRIMER. Articles consisting of a cartridge case made from metal, plastics or other non-flammable material, in which the only explosive component is the primer.	0055, 0379
CASES, COMBUSTIBLE, EMPTY, WITHOUT PRIMER. Articles consisting of cartridge cases made partly or entirely from nitrocellulose.	0446, 0447
CELLS, CONTAINING SODIUM. Articles consisting of hermetically sealed, metal casings which fully enclose the dangerous goods and which are so constructed and closed as to prevent the release of the dangerous goods under normal conditions of transport. In addition to sodium, cells covered by this entry may also contain sulphur, but no other dangerous goods. Although designed and intended to provide a source of electrical energy, these cells are electrically inert at any temperature at which the sodium contained in the cell is in a solid state.	3292
CHARGES, BURSTING. Articles consisting of a charge of detonating explosive such as hexolite, octolite or plastics bonded explosive designed to produce effect by blast or fragmentation.	—
CHARGES, DEMOLITION. Articles containing a charge of a detonating explosive in a casing of fibreboard, plastic, metal or other material. The term excludes the following articles which are listed separately: bombs, mines, etc.	0048
CHARGES, DEPTH. Articles consisting of a charge of detonating explosive contained in a drum or projectile. They are designed to detonate under water.	0056
CHARGES, EXPELLING. A charge of deflagrating explosive designed to eject the payload from the parent articles without damage.	—
CHARGES, EXPLOSIVE, COMMERCIAL without detonator. Articles consisting of a charge of detonating explosive without means of initiation, used for explosive welding, jointing, forming and other metallurgical processes.	0442, 0443, 0444, 0445
CHARGES, PROPELLING. Articles consisting of a propellant charge in any physical form, with or without a casing, for use as a component of rocket motors or for reducing the drag of projectiles.	0271, 0272, 0415, 0491
CHARGES, PROPELLING FOR CANNON. Articles consisting of a propellant charge in any physical form, with or without a casing, for use in a cannon.	0242, 0279, 0414

<i>Term and explanation</i>	<i>UN Number(s), when relevant</i>
CHARGES, SHAPED, without detonator. Articles consisting of a casing containing a charge of detonating explosive with a cavity lined with rigid material, without means of initiation. They are designed to produce a powerful, penetrating jet effect.	0059, 0439, 0440, 0441
CHARGES, SHAPED, FLEXIBLE, LINEAR. Articles consisting of a V-shaped core of a detonating explosive clad by a flexible metal sheath.	0237, 0288
CHARGES, SUPPLEMENTARY, EXPLOSIVE. Articles consisting of a small removable booster used in the cavity of a projectile between the fuze and the bursting charge.	0060
COAL GAS COMPRESSED. The gas obtained by the destructive distillation of bituminous coal.	1023
COATING SOLUTION. Material such as automobile undercoating, drum or barrel lining material, etc., which cannot properly be described as cement, but presents similar hazards during transport. It usually contains flammable solvents.	1139
COMPONENTS, EXPLOSIVE TRAIN, N.O.S. Articles containing an explosive designed to transmit the detonation or deflagration within an explosive train.	0382, 0383, 0384, 0461
CONSUMER COMMODITY. A material which is packed and distributed in a form intended or suitable for retail sales for the purposes of personal care or household use.	—
CONTRIVANCES, WATER-ACTIVATED with burster, expelling charge or propelling charge. Articles whose functioning depends upon physico-chemical reaction of their contents with water.	0248, 0249
CONVEYANCE. A conveyance is a means of transportation such as an aircraft, boat, road vehicle, scooter or lift truck.	
COPRA. The dried meat of coconuts used to produce coconut oil. Copra contains up to 67% oil and may be subject to spontaneous combustion.	1363
CORD, DETONATING, flexible. Articles consisting of a core of detonating explosive enclosed in spun fabric with plastic or other covering unless the spun fabric is siftproof.	0065, 0289
CORD (FUSE), DETONATING, metal clad. Articles consisting of a core of detonating explosive clad by a soft metal tube with or without protective covering. When the core contains a sufficiently small quantity of explosive, the words 'mild effect' are added.	0102, 0104, 0290
CORD, IGNITER. Article consisting of textile yarns covered with black powder or another fast burning pyro-technic composition and of a flexible protective covering; or it consists of a core of black powder surrounded by a flexible woven fabric. It burns progressively along its length with an external flame and is used to transmit ignition from a device to a charge or primer.	0066
CUTTERS, CABLE, EXPLOSIVE. Articles consisting of a knife-edged device which is driven by a small charge of deflagrating explosive into an anvil.	0070
DETONATOR ASSEMBLIES, NON-ELECTRIC, for blasting. Non-electric detonators assembled with and activated by such means as safety fuse, shock tube, flash tube or detonating cord. They may be of instantaneous design or incorporate delay elements. Detonating relays incorporating detonating cord are included. Other detonating relays are included in 'Detonators, non-electric'.	0360, 0361
≠ DETONATORS. Articles consisting of a small metal or plastic tube containing explosives such as lead azide, PETN or combinations of explosives. They are designed to start a detonation train. They may be constructed to detonate instantaneously, or may contain a delay element. The term includes: DETONATORS FOR AMMUNITION and Detonators for blasting both electric and non-electric; Detonating relays without flexible detonating cord are included.	0029, 0030, 0073, 0255, 0267, 0364, 0365, 0366, 0455 0456, 0500
≠ DRESSING, LEATHER. A preparation which usually contains a solvent or other liquid with a low flash point.	—
DYE INTERMEDIATE, N.O.S. A cyclic compound, containing an amino, hydroxy, sulfonic acid, or quinone group or a combination of these groups used in the manufacture of dyes.	1602, 2801, 3143, 3147
ELECTROLYTE. The term commonly applied to the dilute sulphuric acid used in ordinary lead plate storage batteries. The solution of potassium hydroxide used in some storage batteries is also called electrolyte.	—
ENTIRE LOAD. Such a substantial proportion that the practical hazard should be assessed by assuming simultaneous explosion of the whole of the explosive content of the load or package.	—
EXPLODE. The verb used to indicate those explosive effects capable of endangering life and property through blast, heat and projection of missiles. It encompasses both deflagration and detonation.	—

<i>Term and explanation</i>	<i>UN Number(s), when relevant</i>
EXPLOSION OF THE TOTAL CONTENTS. The phrase is used in testing a single article or package or a small stack of articles or packages.	—
EXPLOSIVE, BLASTING. Detonating explosive substances used in mining, construction and similar tasks. Blasting explosives are assigned to one of five types. In addition to the ingredients listed, blasting explosives may also contain inert components such as kieselguhr, and minor ingredients such as colouring agents and stabilizers.	0081, 0082, 0083, 0084, 0241, 0331, 0332
EXPLOSIVE, BLASTING, TYPE A. Substances consisting of liquid organic nitrates such as nitroglycerin or a mixture of such ingredients with one or more of the following: nitrocellulose, ammonium nitrate or other inorganic nitrates, aromatic nitro derivatives or combustible materials such as wood-meal and aluminium powder. Such explosives must be in powdery, gelatinous or elastic form. The term includes dynamite, gelatine, blasting and gelatine dynamites.	0081
EXPLOSIVE, BLASTING, TYPE B. Substances consisting of a) a mixture of ammonium nitrate or other inorganic nitrates with an explosive such as trinitrotoluene, with or without other substances such as wood-meal and aluminium powder, or b) a mixture of ammonium nitrate or other inorganic nitrates with other combustible substances which are not explosive ingredients. Such explosives must not contain nitroglycerin, similar liquid organic nitrates, or chlorates.	0082, 0331
EXPLOSIVE, BLASTING, TYPE C. Substances consisting of a mixture of either potassium or sodium chlorate or potassium, sodium or ammonium perchlorate with organic nitro derivatives or combustible materials such as wood-meal or aluminium powder or a hydrocarbon. Such explosives must not contain nitroglycerin or similar liquid organic nitrates.	0083
EXPLOSIVE, BLASTING, TYPE D. Substances consisting of a mixture of organic nitrated compounds and combustible materials such as hydrocarbons and aluminium powder. Such explosives must not contain nitroglycerin, similar liquid organic nitrates, chlorates or ammonium nitrate. The term generally includes plastic explosives.	0084
EXPLOSIVE, BLASTING, TYPE E. Substances consisting of water as an essential ingredient and high proportions of ammonium nitrate or other oxidizers, some or all of which are in solution. The other constituents may include nitro-derivatives such as trinitrotoluene, hydrocarbons or aluminium powder. The term includes explosives, emulsion; explosives, slurry and explosives, water gel.	0241, 0332
EXPLOSIVE, DEFLAGRATING. A substance, e.g. a propellant, which reacts by deflagration rather than detonation when ignited and used in its normal manner.	—
EXPLOSIVE, DETONATING. A substance which reacts by detonation rather than deflagration when initiated and used in its normal manner.	—
EXPLOSIVE, EXTREMELY INSENSITIVE SUBSTANCE (EIS). A substance which has demonstrated through tests that it is so insensitive that there is very little probability of accidental initiation.	—
EXPLOSIVE, PRIMARY. An explosive substance manufactured with a view to producing a practical effect by explosion which is very sensitive to heat, impact or friction and which, even in very small quantities, either detonates or burns very rapidly. It is able to transmit detonation (in the case of initiating explosive) or deflagration to secondary explosives close to it. The main primary explosives are mercury fulminate, lead azide and lead styphnate.	—
EXPLOSIVE, SECONDARY. An explosive substance which is relatively insensitive (when compared to primary explosives), which is usually initiated by primary explosives with or without the aid of boosters or supplementary charges. Such an explosive may react as a deflagrating or as a detonating explosive.	—
EXTRACTS, AROMATIC OR EXTRACTS, FLAVOURING. Substances used for fragrances or for flavouring foods or beverages. Where they contain a solvent or other liquid with a sufficiently low flash point they are classified as flammable liquids. However, where they contain a liquid which has corrosive or toxic properties they must be classified according to that criteria. They may have obnoxious properties such that in the event of a leakage from the package they may cause extreme discomfort to the crew or passengers.	1169, 1197
FILMS, NITROCELLULOSE BASE. A type of film which consists mainly of nitrocellulose. As such the material has a low ignition temperature and burns rapidly when ignited, evolving gases which are toxic. When new and in good condition the film is reasonably stable and free from liability to spontaneous heating and combustion. Film that has deteriorated badly becomes very unstable and may be liable to spontaneous heating unless kept under water.	1324
FIRE EXTINGUISHER CHARGES. These commonly consist of packages containing sodium bicarbonate (a dry powder) which is non-hazardous, and bottles containing concentrated sulphuric acid, a corrosive liquid.	1774
FIRELIGHTERS. These are usually made from peat, wood shavings, or sawdust and a flammable liquid.	2623

<i>Term and explanation</i>	<i>UN Number(s), when relevant</i>
FIREWORKS. Pyrotechnic articles designed for entertainment.	0333, 0334, 0335, 0336, 0337
FLARES. Articles containing pyrotechnic substances which are designed for use to illuminate, identify, signal or warn. The term includes: FLARES, AERIAL; FLARES, SURFACE.	0092, 0093, 0403, 0404, 0418, 0419, 0420, 0421
FLASH POWDER. Pyrotechnic substance which, when ignited, produces an intense light.	0094, 0305
FRACTURING DEVICES, EXPLOSIVE, for oil wells, without detonator. Articles consisting of a charge of detonating explosive contained in a casing without means of initiation. They are used to fracture the rock around a drill shaft to assist the flow of crude oil from the rock.	0099
FUEL CELL. See Part 1;3.1.	
FUEL CELL CARTRIDGE. An article that stores fuel for discharge into the fuel cell through a valve(s) that controls the discharge of fuel into the fuel cell.	3473, 3476, 3477, 3478, 3479
FUEL CELL ENGINE. See Part 1;3.1.	3166
FUSE/FUZE. Although these two words have a common origin (French <i>fusée, fusil</i>) and are sometimes considered to be different spellings of the same word, it is useful to maintain the convention that FUSE refers to a cord-like igniting device whereas FUZE refers to a device used in ammunition which incorporates mechanical, electrical, chemical or hydrostatic components to initiate a train by deflagration or detonation.	—
FUSE, IGNITER, tubular, metal clad. Article consisting of a metal tube with a core of deflagrating explosive.	0103
FUSE, INSTANTANEOUS, NON-DETONATING (QUICKMATCH). Article consisting of cotton yarns impregnated with fine black powder (quickmatch). It burns with an external flame and is used in ignition trains for fireworks, etc.	0101
FUSE, SAFETY. Article consisting of a core of fine-grained black powder surrounded by a flexible woven fabric with one or more protective outer coverings. When ignited it burns at a predetermined rate without any external explosive effect.	0105
FUZES. Articles designed to start a detonation or a deflagration in ammunition. They incorporate mechanical, electrical, chemical or hydrostatic components and generally protective features. The term includes: FUZES, DETONATING; FUZES, DETONATING with protective features; FUZES, IGNITING.	0106, 0107, 0257, 0316, 0317, 0367, 0368, 0408, 0409, 0410
GALLIUM. A silvery-white metal with a melting point of 30°C; it may be under-cooled to almost 0°C without solidifying. It has the property of very rapidly penetrating the grain boundaries of aluminium alloys and other metals and causing embrittlement.	2803
GAS DRIPS, Hydrocarbon. The liquid that condenses on compression of Pintsch Gas or the condensate from gas mains. It consists principally of a mixture of benzene and unsaturated hydrocarbons.	3295
GRENADES, hand or rifle. Articles which are designed to be thrown by hand or to be projected by a rifle. The term includes: GRENADES, hand or rifle, with bursting charge; GRENADES, PRACTICE, hand or rifle. The term excludes 'grenades, smoke' which are listed under AMMUNITION, SMOKE.	0110, 0284, 0285, 0292, 0293, 0318, 0372, 0452
HYDROCARBON GAS, COMPRESSED. Hydrocarbon gas under high pressure, but not in the liquid condition.	1964
HYDROCARBON GAS, LIQUEFIED. Hydrocarbon gas from natural gas or from distillation of petroleum which are liquefied by pressure.	1965
HYPOCHLORITE SOLUTION. Water solutions containing a soluble hypochlorite varying over a wide range in concentration. The solutions are alkaline and corrosive but are not flammable. If the hypochlorite solution contacts strong acids, a decomposition takes place to produce the noxious chlorine-type gases.	1791

<i>Term and explanation</i>	<i>UN Number(s), when relevant</i>
<p>IGNITERS. Articles containing one or more explosive substances used to start deflagration in an explosive train. They may be actuated chemically, electrically or mechanically. This term excludes the following articles which are listed separately: CORD, IGNITER; FUSE, IGNITER; FUSE, INSTANTANEOUS, NON-DETONATING; FUZES, IGNITING; LIGHTERS, FUSE; PRIMERS, CAP TYPE; PRIMERS, TUBULAR.</p>	0121, 0314, 0315, 0325, 0454
<p>IGNITION, MEANS OF. A general term used in connection with the method employed to ignite a deflagrating train of explosive or pyrotechnic substances (e.g. a primer for a propelling charge, an igniter for a rocket motor, an igniting fuze).</p>	—
<p>INITIATION, MEANS OF. (1) A device intended to cause the detonation of an explosive (e.g. detonator, detonator for ammunition, detonating fuze). (2) The term “with its own means of initiation” means that the contrivance has its normal initiating device assembled to it and this device is considered to present a significant risk during transport but not one great enough to be unacceptable. The term does not apply, however, to a contrivance packed together with its means of initiation provided the device is packaged so as to eliminate the risk of causing detonation of the contrivance in the event of accidental functioning of the initiating device. The means of initiating can even be assembled to the contrivance provided there are protective features such that the device is unlikely to cause detonation of the contrivance in conditions which are associated with transport. (3) For the purposes of classification any means of initiation without two effective protective features should be regarded as Compatibility Group B; an article with its own means of initiation, without two effective protective features, would be Compatibility Group F. However, a means of initiation which itself possesses two effective protective features would be Compatibility Group D; and an article with a means of initiation which possesses two effective protective features would be Compatibility Group D or E. Means of initiation adjudged as having two effective protective features should have been approved by the appropriate national authority. A common and effective way of achieving the necessary degree of protection is to use a means of initiation which incorporates two or more independent safety features.</p>	—
<p>IRON OXIDE, SPENT OR IRON SPONGE, SPENT. A mixture of wood shavings with iron oxide and possibly lime or other material, which has been obtained from coal gas purification after saturation with sulphur. This spent material is very liable to spontaneous heating and ignition.</p>	1376
<p>ISOCYANATES, N.O.S. OR ISOCYANATE SOLUTION, N.O.S. These include a number of chemical products used in the manufacture of plastic foams, synthetic rubber, etc. Some are sufficiently toxic or lachrymatory to need classification as toxic substances, particularly isocyanates in pure form. Others may need to be classified as flammable liquids, depending on their characteristics, and a number may not be subject to these Instructions.</p>	2206, 2478, 3080
<p>JET PERFORATING GUNS, CHARGED, oil well, without detonator. Articles consisting of a steel tube or metallic strip into which are inserted shaped charges connected by detonating cord, without means of initiation.</p>	0124, 0494
<p>LACQUER BASE OR LACQUER CHIPS, NITROCELLULOSE, DRY. It may consist of a colloided solid mixture of nitrocellulose, pigment, gums, and a plasticizer.</p>	—
<p>LIGHTERS, FUSE. Articles of various design actuated by friction, percussion or electricity and used to ignite safety fuse.</p>	0131
<p>LITHIUM BATTERY. Two or more cells which are electrically connected together and fitted with devices necessary for use, for example, case, terminals, marking and protective devices. A single cell battery is considered a “cell” and must be tested according to the testing requirements for “cells” for the purposes of these Instructions and the <i>UN Manual of Tests and Criteria</i> (see also the explanation for “lithium cell”).</p> <p><i>Note.— Units that are commonly referred to as “battery packs”, “modules” or “battery assemblies” having the primary function of providing a source of power to another piece of equipment are, for the purposes of these Instructions and the UN Manual of Tests and Criteria, treated as batteries.</i></p>	3090, 3091, 3480, 3481
<p>LITHIUM CELL. A single encased electrochemical unit (one positive and one negative electrode) which exhibits a voltage differential across its two terminals. Under these Instructions and the <i>UN Manual of Tests and Criteria</i>, to the extent the encased electrochemical unit meets the definition of “cell” herein, it is a “cell”, not a “battery”, regardless of whether the unit is termed a “battery” or a “single cell battery” outside of these Instructions and the <i>UN Manual of Tests and Criteria</i>.</p>	3090, 3091, 3480, 3481
<p>LITHIUM SILICON. A so-called alloy of metallic lithium and silicon used for industrial purposes.</p>	1417
<p>MAGNESIUM SCRAP. Borings, clippings, scalplings, shavings, sheets or turnings from machining operations or cuttings from thin magnesium metal sheets. The scrap can be ignited by external flame and burns intensely and persistently. It does not heat spontaneously. The scrap may have a bright metal lustre or may be dull and sometimes have a painted surface.</p>	—
<p>MASS EXPLOSION. An explosion which affects almost the entire load virtually instantaneously.</p>	—

<i>Term and explanation</i>	<i>UN Number(s), when relevant</i>
MATCHES, SAFETY. Matches, contained in a book, card or box, which are only ignited when struck on a prepared surface.	1944
MATCHES, 'STRIKE ANYWHERE' OR FUSEE. They usually contain phosphorus sesquisulphide, potassium chlorate and other ingredients. The 'strike-anywhere' matches are readily ignited by friction on almost any dry surface.	1331, 2254
METHYLACETYLENE AND PROPADIENE MIXTURE, STABILIZED. A flammable gas mixture that is reasonably stable at ordinary temperatures. Although this is an acetylene derivative, the gas is not shipped dissolved in liquid and cylinders do not require an absorbent filler.	1060
MINES. Articles consisting normally of metal or composition receptacles and a bursting charge. They are designed to be operated by the passage of ships, vehicles or personnel. The term includes 'Bangalore torpedoes'.	0136, 0137, 0138, 0294
MOTOR FUEL ANTI-KNOCK MIXTURE. A mixture of one or more organic lead components such as tetraethyl lead, triethylmethyl lead, diethyldimethyl lead, ethyltrimethyl lead, and tetramethyl lead, with one or more halogen compounds such as ethylene dibromide and ethylene dichloride.	1649
NITRATING ACID MIXTURE. A mixture of nitric and sulphuric acids used for the nitration of glycerin, cellulose or other organic substances. This acid mixture coming in contact with organic matter commonly causes fire, unless the mixture contains much water.	1796, 1826
OIL GAS, COMPRESSED. A gas made by the reaction of steam at high temperatures on gas oil or similar fractions of petroleum, or by high-temperature cracking of gas oil. The gas is flammable, but it is classified as a toxic gas because it contains a high proportion of carbon monoxide.	1071
OXYGEN GENERATOR, CHEMICAL. A device containing chemicals which upon activation releases oxygen as a product of chemical reaction. Chemical oxygen generators are used for the generation of oxygen for respiratory support, e.g. in aircraft, submarines, spacecraft, bomb shelters and breathing apparatus. Oxidizing salts such as chlorates and perchlorates of lithium, sodium and potassium, which are used in chemical oxygen generators, evolve oxygen when heated. These salts are mixed (compounded) with a fuel, usually iron powder, to form a chlorate candle, which produces oxygen by continuous reaction. The fuel is used to generate heat by oxidation. Once the reaction begins, oxygen is released from the hot salt by thermal decomposition (a thermal shield is used around the generator). A portion of the oxygen reacts with the fuel to produce more heat which produces more oxygen, and so on. Initiation of the reaction can be achieved by a percussion device, friction device or electric wire.	3356
PLASTIC SOLVENT, N.O.S. A name commonly used for mixtures of liquids employed for dissolving plastics or for thinning plastic cements. In general, they may contain flammable liquids, such as acetone, amyl acetate, or some of the alcohols or ketones. The classification is determined by the flash point.	—
POLYESTER RESIN KIT. The proper shipping name 'Polyester resin kit' covers different kits such as filler, bonding and sealing compounds, chemical anchors and fibreglass repair kits. A polyester resin kit commonly consists of an unsaturated polyester resin mixed with styrene and a separate hardener (usually a phlegmatized organic peroxide) as a minor component. The main component (viscous liquid or paste) is inherently flammable due to the styrene content (flash point 29EC to 32EC).	3269
POLYMERIC BEADS, EXPANDABLE. Semi-processed products used to manufacture polymeric articles, and which have been impregnated with a flammable gas or liquid as a blowing agent. They may evolve small quantities of flammable gas during transport.	2211
POTASSIUM SODIUM ALLOYS. Mixtures of metallic sodium and potassium that are solid at ordinary temperatures. All mixtures, regardless of physical state, will react vigorously with water and may be self-igniting. The mixtures are all combustible.	1422
POTASSIUM SULPHIDE, ANHYDROUS. A reddish-coloured solid having a strong odour. It is hygroscopic and oxidizes spontaneously on contact with air. Spontaneous ignition may occur in material improperly packed.	1382
POWDER CAKE, (POWDER PASTE) WETTED. Substance consisting of nitrocellulose impregnated with not more than 60 per cent of nitroglycerin or other liquid organic nitrates or a mixture of these.	0159, 0433
POWDER, SMOKELESS. Substance based on nitrocellulose used as propellant. The term includes propellants with a single base (nitrocellulose (NC) alone), those with a double base (such as NC and nitroglycerin (NG)) and those with a triple base (such as NC/NG/nitroguanidine). Cast, pressed or bag-charges of smokeless powder are listed under CHARGES, PROPELLING or CHARGES, PROPELLING FOR CANNON.	0160, 0161
PREMIXING BURNER LIGHTER. Gas lighter in which fuel and air are mixed before being supplied for combustion, such as lighters producing a blue flame.	

<i>Term and explanation</i>	<i>UN Number(s), when relevant</i>
PRIMERS, CAP TYPE. Articles consisting of a metal or plastic cap containing a small amount of primary explosive mixture that is readily ignited by impact. They serve as igniting elements in small arms cartridges, and in percussion primers for propelling charges.	0044, 0377, 0378
PRIMERS, TUBULAR. Articles consisting of a primer for ignition and an auxiliary charge of deflagrating explosive such as black powder used to ignite the propelling charge in a cartridge case for cannon, etc.	0319, 0320, 0376
PROJECTILES. Articles such as a shell or bullet which are projected from a cannon or other artillery gun, rifle or other small arm. They may be inert, with or without tracer, or may contain a burster or expelling charge or a bursting charge. The term includes: PROJECTILES, inert, with tracer; PROJECTILES, with burster or expelling charge; PROJECTILES, with bursting charge.	0167, 0168, 0169, 0324, 0344, 0345, 0346, 0347, 0424, 0425, 0426, 0427, 0434, 0435
PROPELLANT, LIQUID. A substance consisting of a deflagrating liquid explosive, used for propulsion.	0495, 0497
PROPELLANTS. Deflagrating explosives used for propulsion or for reducing the drag of projectiles.	—
PROPELLANT, SOLID. A substance consisting of a deflagrating solid explosive, used for propulsion.	0498, 0499
PYROPHORIC LIQUID/SOLID, ORGANIC/INORGANIC. A substance that may ignite in air at or below room temperature in the absence of added heat, shock or friction.	2845, 2846, 3194, 3200
PYROXYLIN SOLUTION. Pyroxylin (nitrocellulose) or soluble cotton dissolved in amyl acetate or other organic solvents. Pyroxylin solution is used as a basis for the manufacture of lacquer, leather coating compounds, leather substitutes, cements, etc. It is generally more viscous than ordinary lacquers.	—
RELEASE DEVICES, EXPLOSIVE. Articles consisting of a small charge of explosive with means of initiation. They sever rods or links to release equipment quickly.	0173
ROCKET MOTORS. Articles consisting of a solid, liquid or hypergolic fuel contained in a cylinder fitted with one or more nozzles. They are designed to propel a rocket or a guided missile. The term includes: ROCKET MOTORS; ROCKET MOTORS WITH HYPERGOLIC LIQUIDS, with or without expelling charge; ROCKET MOTORS, LIQUID FUELLED.	0186, 0250, 0280, 0281, 0322, 0395, 0396
ROCKETS. Articles consisting of a rocket motor and a payload which may be an explosive warhead or other device. The term includes guided missiles and: ROCKETS, LINE-THROWING; ROCKETS, LIQUID FUELLED, with bursting charge; ROCKETS, with bursting charge; ROCKETS, with expelling charge; ROCKETS, with inert head.	0180, 0181, 0182, 0183, 0238, 0240, 0295, 0397, 0398, 0436, 0437, 0438, 0453
+ SAFETY DEVICES, ELECTRICALLY INITIATED. Articles which contain pyrotechnical substances or dangerous goods of other classes and are used in vehicles, vessels or aircraft to enhance safety to persons. Examples are: air bag inflators, air bag modules, seat-belt pretensioners and pyromechanical devices. These pyromechanical devices are assembled components for tasks such as but not limited to separation, locking, or release-and-drive or occupant restraint. The term includes Safety devices, pyrotechnic.	0503, 3268
SECURITY TYPE EQUIPMENT. Equipment such as attaché cases, cash boxes, cash bags, etc., incorporating dangerous goods, for example lithium batteries, gas cartridges and/or pyrotechnic material.	
SIGNALS. Articles containing pyrotechnic substances designed to produce signals by means of sound, flame or smoke or any combinations thereof. The term includes: SIGNAL DEVICES, HAND; SIGNALS, DISTRESS, ship; SIGNALS, RAILWAY TRACK, EXPLOSIVE; SIGNALS, SMOKE.	0191, 0192, 0193, 0194, 0195, 0196, 0197, 0313, 0373, 0487, 0492, 0493
SLUDGE ACID. The acid waste resulting from oil refining, or from nitrating processes. It generally has somewhat the same hazards as the original acid.	1906
SODA LIME. A mixture of calcium oxide or calcium hydroxide with sodium hydroxide.	1907
SODIUM SULPHIDE, ANHYDROUS. A yellow or reddish-coloured solid having a strong odour. It is hygroscopic and oxidizes spontaneously on contact with air. Spontaneous ignition may occur in material improperly packed.	1385
SOLVENTS. Substances capable of dissolving other substances to form a uniformly dispersed mixture or solution. Examples of organic solvent groups are esters, ethers, ketones, amines and nitrated and chlorinated hydrocarbons. Many solvents are flammable and toxic to varying degrees.	—

<i>Term and explanation</i>	<i>UN Number(s), when relevant</i>
SOUNDING DEVICES, EXPLOSIVE. Articles consisting of a charge of detonating explosive. They are dropped from ships and function when they reach a predetermined depth or the sea bed.	0204, 0296, 0374, 0375
STABILIZED. Stabilized means that the substance is in a condition that precludes uncontrolled reaction. This may be achieved by methods such as the addition of an inhibiting chemical, degassing the substance to remove dissolved oxygen and inerting the air space in the package, or maintaining the substance under temperature control.	
SUBSTANCES, EXPLOSIVE, VERY INSENSITIVE (SUBSTANCES, EVI), N.O.S. Substances that present a mass explosion hazard but are so insensitive that there is very little probability of initiation or of transition from burning to detonation (under normal conditions of transport) and that have passed Test Series 5.	0482
SULPHURIC ACID, FUMING. Sulphuric acid in which an excess of sulphur trioxide has been dissolved. It evolves toxic fumes whilst ordinary sulphuric acid does not.	1831
SULPHURIC ACID, SPENT. Sulphuric acid usually of high concentration, which has been used for chemical processes and contains residual organic matter.	1832
TORPEDOES. Articles containing an explosive or non-explosive propulsion system and designed to be propelled through water. They contain an inert head or a warhead. The term includes: TORPEDOES, LIQUID FUELLED, with inert head; TORPEDOES, LIQUID FUELLED, with or without bursting charge; TORPEDOES, with bursting charge.	0329, 0330, 0449, 0450, 0451
TOTAL CONTENTS. Such a substantial proportion that the practical hazard should be assessed by assuming simultaneous explosion of the whole of the explosive content of the load or package.	—
TRACERS FOR AMMUNITION. Sealed articles containing pyrotechnic substances, designed to reveal the trajectory of a projectile.	0212, 0306
TURBINE ENGINES. Generic term used for turbine engines fuelled by flammable liquid, flammable gas or other combustible fuels. They may power fixed wing aircraft, rotorcraft, hover craft (cushion craft), marine vessels, land vehicles, pumps and power-generating plants.	3166
TURPENTINE SUBSTITUTE. A petroleum distillate which might contain some aromatic components and which usually has a flash point of approximately 40EC. White spirit is a synonym for turpentine substitute.	1300
WARHEADS. Articles consisting of detonating explosives. They are designed to be fitted to a rocket, guided missile or torpedo. They may contain a burster or expelling charge or bursting charge. The term includes: WARHEADS, ROCKET, with burster or expelling charge; WARHEADS, ROCKET, with bursting charge; WARHEADS, TORPEDO, with bursting charge.	0221, 0286, 0287, 0369, 0370, 0371
WATT-HOUR RATING. Expressed in watt-hours, the watt-hour rating is calculated by multiplying a cell's or battery's rated capacity, in ampere-hours, by its nominal voltage.	3480, 3481
ZIRCONIUM SUSPENDED IN A FLAMMABLE LIQUID. Very finely divided metallic zirconium which is usually suspended in some highly volatile and flammable liquid. If spilled, the material is liable to self-ignition.	1308

Attachment 3

**NOTIFIED VARIATIONS FROM
THE INSTRUCTIONS**

Chapter 1

VARIATIONS NOTIFIED BY STATES

1.1 Paragraph 2.2.1 of Annex 18 provides that Contracting States shall take the necessary measures to achieve compliance with the detailed provisions of these Technical Instructions. However, where a Contracting State does adopt different provisions from those specified in these Technical Instructions, 2.5 of Annex 18 requires that ICAO be notified promptly of such State provisions for publication in the Technical Instructions.

≠ 1.2 Those different provisions which were notified to ICAO by States, prior to 31 July 2014, appear in Table A-1. The variations notified by States, unless the context makes it otherwise apparent, apply as follows:

- a) where such variations result in more restrictive provisions than those contained in these Instructions, they apply to the transport of dangerous goods by air:
 - 1) to, from or through all territory subject to the sovereignty of the notifying State by all operators; and
 - 2) outside the territory of the notifying State to all operators for whom the notifying State is the State of the Operator;
- b) where such variations result in less restrictive provisions than those contained in these Instructions, the variations are listed for information only and may only be applied within the territory of the notifying State by operators for whom the notifying State is the State of the Operator.

1.3 Throughout the Instructions, the identifying code of each State variation has been placed beneath the heading of the Chapter(s) principally affected. Where State variations apply to specific articles or substances, the identifying code appears in column 6 of Table 3-1 against the appropriate proper shipping name.

1.4 The table of State variations (Table A-1) is based on data provided by the States concerned. This table is provided for information only and any further details required should be obtained from the appropriate government department.

≠ 1.5 Table A-1 is also published on the ICAO website at www.icao.int/safety/DangerousGoods. If a State needs to make variations based on new requirements appearing in this edition of the Instructions, it should notify ICAO by using the form appearing at the end of this Chapter. Such variations will appear on the ICAO website.

1.6 Variations have been notified by the following States:

Australia — AU		Luxembourg — LU
Belgium — BE		Malaysia — MY
Brazil — BR		Netherlands — NL
Brunei Darussalam — BN		Oman — OM
+ Cambodia — KH		Pakistan — PK
Canada — CA		+ Peru — PE
China — CN		Poland — PL
Hong Kong SAR, China — HK		Romania — RO
Macao SAR, China — MO		Russian Federation — RU
Croatia — HR		Saudi Arabia — SA
Democratic People's Republic of Korea — KP		Singapore — SG
Denmark — DK		South Africa — ZA
Fiji — DQ		Spain — ES
France — FR		Sri Lanka — VC
Germany — DE		Switzerland — CH
India — IN		Turkey — TR
Iran (Islamic Republic of) — IR		Ukraine — UA
Italy — IT		United Arab Emirates — AE
Jamaica — JM		United Kingdom — GB
Japan — JP		United States — US
Kyrgyz Republic — KG		Vanuatu — VU

Table A-1. State variations

The identifying code for each State variation consists of the two-letter identifier for that State plus a sequential number. Variations are listed in the alphabetical order of these identifying codes. For each variation the relevant Part and Chapter or paragraph numbers of the Instructions are given.

<i>Identifying code</i>	<i>Variation</i>	<i>Relevant paragraphs</i>
AE — UNITED ARAB EMIRATES		
AE 1	Transportation of dangerous goods to, from or within the UAE must be subject to compliance with the provisions of these Instructions and the UAE Civil Aviation Regulations. A copy of the UAE Civil Aviation Regulations can be obtained online using the General Civil Aviation Authority (GCAA) website, i.e. www.gcaa.ae .	
AE 2	Cargo agents and freight forwarders accepting or processing dangerous goods for transport by air must ensure that they have a minimum of two GCAA dangerous goods certified staff available at all times to handle such consignments. This is a prerequisite for GCAA to approve the dangerous goods freight forwarder application or to renew their certificate. Ground handling agents must only accept dangerous goods from GCAA certified cargo agents or freight forwarders by trained and qualified dangerous goods acceptance staff, according to Table 1-4 of these Instructions (Table 1.5.A of the IATA Dangerous Goods Regulations).	1;4
AE 3	The request to carry dangerous goods under Special Provision A1, A2 or other State exemptions or approvals by the competent authority must be submitted to the Safety and Security Section, Department of Security and Infrastructure GCAA, at least five working days before the planned flight. The address and contact details are as follows: Department of Security and Infrastructure Safety and Security Section P.O. Box 6558 Abu Dhabi United Arab Emirates Fax: +971 2 4054461, +971 4 2111502 E-mail: dangerousgoods@gcaa.ae	1;1 3;3
AE 4	The operator must be responsible for coordinating with the shipper and consignee the return of any remaining unclaimed, damaged and/or leaking dangerous goods to the State of Origin whenever instructed to do so by GCAA.	7;3
AE 5	Dangerous goods shipments to, from, within or transiting through the United Arab Emirates (UAE) must include emergency response information, as described below: The Transport Document (shipper's declaration for dangerous goods) must include a 24-hour emergency response telephone number, which must include the international code and area code, for use in the event of an incident or accident involving dangerous goods. The number must be monitored by an individual who can be contacted in case of an emergency and who: 1) is able to converse in English; 2) is knowledgeable of the hazards and characteristics of the dangerous goods being transported; 3) has comprehensive emergency response and accident mitigation information for the dangerous goods or has immediate access to a person who possesses such knowledge and information. (See 5;4 and 7;4 of these Instructions and 8.1.6.11, 9.5.1 and 10.8.3.11 of the IATA Dangerous Goods Regulations.)	5;4
AE 6	The dangerous goods acceptance checklist must reflect applicable requirements contained in the latest Instructions and IATA Dangerous Goods Regulations.	7;1,3
AE 7	An import, export and/or transit permit(s) must be obtained from the Radiation Safety Department of the Federal Authority for Nuclear Regulation (FANR) before forwarding radioactive material to, from and via the UAE. The contact details of the Department of Radiation Protection and Control within the UAE is as follows:	5;4

Identifying code	Variation	Relevant paragraphs
	Federal Authority for Nuclear Regulation P.O. Box 112021 Abu Dhabi United Arab Emirates Telephone: +971 2 651 6644 Facsimile: +971 2 651 6661 Website: www.fanr.gov.ae	
#	AE 8 Air operators may carry dangerous goods to, from and via the UAE provided the air operator is approved to transport dangerous goods by the Civil Aviation Authority of its State of Registry or the State of the Operator or the State of Origin.	1;1
	AE 9 The United Arab Emirates destined and trans-shipment of arms and ammunitions, explosives and all other Class 1 dangerous goods require permission from the Ministry of Interior (minimum 48 hours pre-alert notification required before forwarding the shipment). Arms and ammunition may not be imported except with a licence obtained from the United Arab Emirates Ministry of Defence before forwarding the shipment.	
AU — AUSTRALIA		
The Australian national authority for Annex 18 and competent authority for these Instructions is the:		
	Civil Aviation Safety Authority (CASA) GPO Box 2005 Canberra ACT 2601 Australia E-mail: dg@casa.gov.au Telephone: +61 131757 Facsimile: +61 2 6217 1300 Website: www.casa.gov.au/dg	
AU 1	Dangerous goods requiring approval under Special Provisions A1 or A2 of the Technical Instructions may only be carried on a passenger or cargo aircraft in Australian territory with the approval of the Civil Aviation Safety Authority (CASA). Applications for approval should be lodged with CASA at least ten days prior to the proposed flight.	Table 3-1 3,3
AU 2	Import and/or export of radioactive material to Australia	Table 3-1 3,3
	A permit is required to import or export radioactive materials and can be obtained on application to the Australian Radiation Protection and Nuclear Safety Agency (ARPANSA). There are two categories of import permit available; one applies to medical radioisotopes, the other to non-medical radioisotopes. It is prohibited to import radioactive waste to Australia.	
	Further information and application forms are available on the ARPANSA website at:	
	http://www.arpansa.gov.au	
	Applications and inquiries can be made to:	
	Import/Export Permits Officer - ARPANSA P.O. Box 655 Miranda NSW 1490 Australia Telephone: +61 2 9541 8333 Facsimile: +61 2 9541 8314 E-mail: info@arpansa.gov.au	

Identifying code	Variation	Relevant paragraphs
≠	<p>AU 3 Infectious substances other than human blood products, human urine and human tissue, are prohibited from entry to Australia without prior approval from Australian Authorities. Requests for approval should be addressed to:</p> <p style="padding-left: 40px;">Department of Agriculture Biologicals Program GPO Box 858 Canberra ACT 2601 Australia Telephone: +61 2 6272 4578 Facsimile: +61 2 6249 1798 Website: http://www.daff.gov.au/biosecurity/import/biological</p>	Table 3-1
AU 4	<p>For the purposes of compliance with 7;4.7, notification of a dangerous goods incident is to be reported to the Civil Aviation Safety Authority (CASA) within two working days. This notification is in addition to, and not instead of, that required under Annex 13.</p>	7;4.7
AU 5	<p>Where a package(s) of dangerous goods is permitted by these Instructions for carriage on both a passenger and cargo aircraft and the package(s) has affixed the "Cargo aircraft only" label in accordance with a State Variation(s) (e.g. US 2, US 10, US 13, etc.), then the package(s) may be transported on both passenger and cargo aircraft within Australia beyond the first port of unloading of the package(s) in Australia, but in these circumstances the "Cargo aircraft only" label must be removed. The "Cargo aircraft only" label may be removed by the operator, the shipper or an agent of the operator or shipper. The shipper must provide the appropriate dangerous goods transport document with the package(s) and, where applicable, an air waybill (or consignment note), prepared in accordance with these Instructions for transport of the package on both a passenger and cargo aircraft within Australia. When following the provisions of AU 05, the operator must complete a dangerous goods acceptance check in accordance with 7;1 prior to further transport of the package(s) aboard an aircraft within Australia.</p>	5;3 5;4 7;1
BE — BELGIUM		
BE 1	<p>Definition of "explosive substance": According to the Belgian regulations any substance likely to be used for its explosive, deflagrating or pyrotechnic properties is considered an explosive substance.</p>	1;3.1
BE 2	<p>No transport by air of any explosive may take place from, to or in transit through Belgium except by authorization of the Minister responsible for the explosives service, who may grant exemptions to the methods of packaging.</p> <p>Applications may be made only by persons or corporations having a residence or an office in Belgium. When this is not the case, the applicant must have a responsible representative, residing in Belgium and approved by Ministerial Decree (information on this subject is obtainable from the:</p> <p style="padding-left: 40px;">Service des Explosifs Ministère des Affaires Economiques Konig Albert II-laan 16 1000 Bruxelles Telephone: 322 206 4111 Facsimile: 322 206 5752)</p>	1;1.2 2;1.5 4;3
	<p>The authorization for to which reference is made above is furthermore subject to the agreement of the:</p>	
	<p style="padding-left: 40px;">Belgian Civil Aviation Administration Ministry of Communications and Infrastructure, CCN rue du Progrès 80 1030 Bruxelles Telephone: 322 206 3211 Facsimile: 322 206 3290</p>	
	<p>These various provisions are issued by the Belgian authority for regulation of explosive (Royal Decree of 23 September 1958, amended), authorization for transport by air being therefore also issued, in practice, only on a case-by-case basis, except with respect to products considered in Belgium as safety ammunition or fireworks for which an authorization covering several shipments over a period of time may in principle be granted.</p>	

Identifying code	Variation	Relevant paragraphs
	It should be noted that in the case of importation or exportation or transit partially over land, any transport that is authorized only case-by-case is subject to prior application specifying the complete itinerary, including the land portion.	
BE 3	Those substances listed in Table 3-1 with "BE 3" shown in column 6 are defined as "explosive substances" and are subject to the conditions of Variation BE 2.	Table 3-1
BE 4	<p>Prior authorization of the:</p> <p>Federal Agency for Nuclear Control Ravensteinstraat 36 1010 Bruxelles Telephone: 322 289 2111 Facsimile: 322 289 2121 E-mail: info@fanc.fgov.bc</p>	1;1.2 2;7 5;1.2.2
	<p>is required for transport from, to or in transit through Belgium of radioactive substances and fissile substances of which the quantities exceed the limits of activity defined in the General Regulations for the Protection of the Population, Workers and Environment against the Danger of Ionizing Radiations (Royal Decree of 20 July 2001). Authorization for transport by air is furthermore subject to the agreement of the:</p> <p>Belgian Civil Aviation Administration Ministry of Communications and Infrastructure, CCN rue du Progrès 80 1030 Bruxelles</p> <p>The carriage in aircraft over the territory of the Kingdom of Belgium of:</p> <ol style="list-style-type: none"> 1) fissile radioactive material as defined in ICAO Doc 9284, 2;7.1 in quantities exceeding the limits set out in 2;7.2.3.5; and 2) radioactive material: <ul style="list-style-type: none"> — in a Type B(U) package containing more than 3000 A₁ or 3000 A₂ or 1000 TBq, whichever is the lower; or — in a Type B(M) package; or — in a Type C package containing more than 3000 A₁ or 3000 A₂ or 1000 TBq, whichever is the lower; or — transported under special arrangement <p>shall not be accepted without prior permission by the Belgian Civil Aviation Administration.</p>	
BE 5	<p>The following requirements apply to aircraft registered:</p> <ol style="list-style-type: none"> a) in Belgium no matter where they are operating; and b) in a State other than Belgium and which are not required to operate under and in accordance with Annex III to Council Regulation (EC) NO. 3922/1991 of 16 December 1991 on the harmonization of technical requirements and administrative procedures in the field of civil aviation ("EU-OPS"), when they are operating in Belgium. <p>Aircraft may only carry dangerous goods with the prior approval of the Civil Aviation Authority. Carriage of such goods must be in compliance with the ICAO Technical Instructions. Application for a general or special authorization must be submitted to:</p> <p>Belgian Civil Aviation Authority Operations Department — Dangerous Goods CCN — 2nd Floor Vooruitgangstraat 80 — Bus 5 B-1030 Brussels Belgium Telephone: +32 2 277 43 58 Facsimile: +32 277 42 57 E-mail: koenraad.clerbout@mobilif.fgov.be</p> <p>This variation does not apply:</p> <ol style="list-style-type: none"> a) to aircraft registered in a State other than Belgium and which are required to operate under and in accordance with EU-OPS, providing an approval granted by such a State is held and a copy of this approval is submitted to the Belgian Civil Aviation Authority; 	1;1.2

<i>Identifying code</i>	<i>Variation</i>	<i>Relevant paragraphs</i>
	<p>b) unless otherwise specified in the ICAO Technical Instructions, to dangerous goods in the case of overflight of the Belgian territory by foreign operators, provided the operator has permission from its State of Registry to carry dangerous goods in accordance with the provisions of these Instructions; or</p> <p>c) to the transport of dry ice (carbon dioxide, solid), UN 1845, when used for cooling purposes in combination with goods not subject to these Instructions. All other requirements of these Instructions concerning the transport of dry ice remain applicable.</p>	
BN — BRUNEI DARUSSALAM		
BN 1	Negara Brunei Darussalam has selected the English language for use in all documentation and correspondence with respect to the transport of dangerous goods by air. The English version of Annex 18 and the Technical Instructions will be used.	5;4
BR — BRAZIL		
BR 1	<p>The Brazilian national authority for Annex 18 and competent authority for these Instructions is the:</p> <p style="margin-left: 40px;">Agência Nacional de Aviação Civil (ANAC) Superintendência de Padrões Operacionais — SPO Gerência de Operações de Empresas de Transporte Aéreo — GCTA Gerência Técnica de Artigos Perigosos — GTAP Av. Presidente Vargas 850 — 12º andar Cep.: 20.071-001 Centro Rio de Janeiro Brazil Email: artigo.perigoso@anac.gov.br Telephone: +55 21 3501-5526</p>	
BR 2	Transportation of dangerous goods to, from or within Brazil must be subject to compliance with the provisions of these Instructions and the Brazilian Civil Aviation Regulations. A copy of all national regulations can be obtained on the following website: www.anac.gov.br/cargaaerea .	
BR 3	Air operators transporting dangerous goods must submit a monthly report of all dangerous goods transported from or within Brazil by the tenth working day of the following month. Further information and a report template are available on the website: www.anac.gov.br/cargaaerea .	5;4
BR 4	Dangerous goods requiring exemption or approval under the Technical Instructions may only be carried on a passenger or cargo aircraft to, from or within Brazil with the approval of the National Civil Aviation Agency (ANAC). The request must be submitted at least fifteen days before the proposed flight for approvals and sixty days for exemptions. Further information and a request form may be obtained on the website: www.anac.gov.br/cargaaerea or by email: artigo.perigoso@anac.gov.br .	1;1
BR 5	For the carriage of dangerous goods originating in Brazil, the template of the shipper's declaration for dangerous goods provided in Supplementary Instruction IS 175-001 must be used. An open form may be used instead of a column form, provided all the information is given on the shipper's declaration for dangerous goods. In addition, electronic data are allowed provided it can be reproduced in a printed format if requested by the Brazilian authority.	5;4
BR 6	For all domestic transport in Brazilian territory, the Portuguese and English languages are permitted for dangerous goods markings and transport document, except the proper shipping name which must be in English. English must be used for all dangerous goods markings and on transport documents for international transport in Brazilian territory, in addition to the languages required by the States of transit and destination. The information on the transport document may be shown in Portuguese in addition to the information shown in English.	5;2 5;4

<i>Identifying code</i>	<i>Variation</i>	<i>Relevant paragraphs</i>
BR 7	National legislation in Brazil specifies that training requirements are described in Supplementary Instruction IS 175-002. All employees working in Brazilian territory must be trained according to this instruction. A copy can be obtained on the following website: www.anac.gov.br/cargaarea .	1;4
BR 8	Transportation of radioactive material from or within Brazil is subject to the approval of the National Commission for Nuclear Energy (CNEN): CNEN — Transport Safety Service Rua General Severiano, 90/401 Postal Code : 22.290-900 Telephone : +55-21-2173-2308 Email : nbruno@cnen.gov.br Website: www.cnen.gov.br	1;6 5;1.2 5;4
CA — CANADA		
Any request concerning the applicability of variations CA 1, CA 2 or CA 3 must be addressed to: Canadian Nuclear Safety Commission Transport Licensing and Strategic Support Division Directorate of Nuclear Substance Regulation P.O. Box 1046 — Station B 280 Slater Street Ottawa, Ontario Canada K1P 5S9 Telephone: toll free, Canada only: 1-800-668-5284 Telephone: (613) 995-5894 Facsimile: (613) 995-5086 E-mail: transport@cnsccsn.gc.ca		
CA 1	Fissile radioactive material in any quantity may not be transported by aircraft to, from or over Canada without prior permission.	2;7 4;9 5;1, 5;3 6;7 7;1, 7;2
CA 2	"Type IP-1" and "Type IP-2" as prescribed in 4;9.2.5 for LSA material and SCO "not under exclusive use" shall be replaced with "Type IP-3".	4;9.2.5
CA 3	Type B(U) radioactive material packages must be approved by the Canadian Nuclear Safety Commission.	2;7 6;7
CA 4	In addition to the Transportation of Dangerous Goods Regulations and the ICAO Technical Instructions, the transportation by air of radioactive material to, from or within Canada is subject to the provisions of the Packaging and Transport of Nuclear Substances Regulations made by the Canadian Nuclear Safety Commission.	2;7 4;9 5;1, 5;2, 5;3, 5;4 6;7 7;1, 7;2, 7;3, 7;4
≠ CA 5	Infectious substances assigned to Category B (UN 3373) and radioactive materials are not permitted in the mail in Canada.	1;2.3
CA 6	The transportation by air of dangerous goods to, from or within Canada is subject to the provisions of the Transportation of Dangerous Goods Regulations and of the ICAO Technical Instructions, as referenced in the said Regulations. Requests for a copy of the Transportation of Dangerous Goods Regulations of Canada in document (Doc No. RE-4631), computer or microfiche format should be sent to: Canada Communication Group — Publishing Ottawa, Ontario Canada K1A 0S9	1;1

Identifying code	Variation	Relevant paragraphs
	<p>or see the following website for the text of the Transportation of Dangerous Goods Regulations of Canada:</p> <p>http://www.tc.gc.ca/eng/tdg/clear-tofc-211.htm</p>	
#	<p>CA 7 Dangerous goods requiring approval under Special Provisions A1, A2 or A201 of the Technical Instructions may only be transported to, from or within Canada with the approval of the Canadian authority for the air transport of dangerous goods.</p> <p>The Canadian authority for the transport of dangerous goods for CA 7:</p> <p>Chief, Technical Advisor, Special Regulatory Projects Transport Canada Transport Dangerous Goods Directorate 330 Sparks Street Ottawa, Ontario Canada K1A 0N5 Facsimile: (613) 993-5925 Email: tdgapprovals-approbationstmd@tc.gc.ca</p>	Table 3-1 Table 3-2
#	<p>CA 8 The entry into Canada of infectious substances affecting animals, UN 2900, and infectious substances affecting humans, UN 2814, is subject to the requirements of the Health of Animals Act (1990, c.21) and the Human Pathogens Importation Act (2009) and Regulations (SOR/94-558) respectively, and prior approval from the Canadian Food Inspection Agency and/or the Public Health Agency of Canada is required. Requests for approval should be addressed to:</p> <p>Centre for Biosecurity 100 Colonnade Road, Ottawa, Ontario, Canada K1A 0K9 Telephone: (613) 957-1779 Facsimile: (877) 248-3528 http://www.publichealth.gc.ca/ http://www.phac-aspc.gc.ca/lab-bio/regul/hpta-lapht-eng.php</p>	2;6
#	<p>CA 9 In addition to the information required in 5;4, the dangerous goods transport document must:</p> <ul style="list-style-type: none"> — have, on the left and right margins, red hatchings that are oriented to the right or to the left; — contain information required on a dangerous goods transport document that is easy to identify, legible, in indelible print and in English or French; — include the words “24-hour number” or “numéro de 24-heures” or an abbreviation of these words, followed by a telephone number, including the area code and country code where applicable, at which the consignor (or his/her representative) can be reached immediately and from whom technical information can be obtained about the dangerous goods in transport, without breaking the telephone connection made by the caller; and — include the reference number preceded by ERP or ERAP or PIU and the telephone number, including the area code, to immediately activate the plan when the dangerous goods being transported require an emergency response assistance plan in accordance with Part 7 of the Canadian Transportation of Dangerous Goods Regulations. 	5;4
#	<p>CA 10 A person must not handle, offer for transport, or transport dangerous goods included in Class 2, Gases, in a means of containment unless the means of containment is manufactured, selected and used in accordance with section 5.10 or 5.11 of the Canadian Transportation of Dangerous Goods Regulations.</p>	4;4
#	<p>CA 11 A document that is issued to a foreign member of the flight crew of an aircraft registered in a country that is a member State of the International Civil Aviation Organization and which indicates that the crew member is trained to transport dangerous goods by air is a valid training certificate for the purposes of the Canadian Transportation of Dangerous Goods Regulations when that document is valid in a member State. This document must be shown to an inspector upon request.</p>	1;4

<i>Identifying code</i>	<i>Variation</i>	<i>Relevant paragraphs</i>
≠	CA 12 When a “dangerous goods accident” or a “dangerous goods incident”, as defined in the ICAO Technical Instructions, occurs on board an aircraft in Canada or at a Canadian aerodrome or at a Canadian air cargo handling facility, reporting must be done in accordance with the requirements found in Part 8 — Accidental Release and Imminent Accidental Release, of the Canadian Transportation of Dangerous Goods Regulations.	7;4
>		
	CH — SWITZERLAND	
	CH 1 Not used.	
	CH 2 Not used.	
	CH 3 According to the radiological protection ordinance, transport within, as well as into and out of Switzerland does not require a prior authorization for the following UN numbers: 2908, 2909, 2910, 2911, 2912, 2915, 2916, 3321 and 3332. Prior authorizations for transport of Class 7 substances under other UN numbers are issued by the: Federal Office of Public Health Radiation Protection Division 3003 Berne, Switzerland Facsimile: +41 31 322 83 83 For further information, please contact the surveillance authority: Suva 6002 Lucerne, Switzerland Telephone: +41 41 419 61 33 Facsimile: +41 41 419 62 13)	1;1.2 5;1.2 7;1
	CH 4 Nuclear materials containing plutonium in any quantity must not be transported in Swiss airspace. Not considered as nuclear materials are any special fissile materials with a weight of up to 15 grams.	2;7 Table 2-12
	CN — CHINA	
	CN 1 Operators wishing to carry dangerous goods in aircraft to, from or over China must obtain prior written permission from the Civil Aviation Administration of China. Further information may be obtained from: Department of Air Transport Civil Aviation Administration of China P.O. Box 644 155 Dongsì St. West Beijing, China Telephone: +86 10 64091929 +86 10 64091918 Facsimile: +86 10 64091968	7;1
	HK — HONG KONG SPECIAL ADMINISTRATIVE REGION, CHINA	
	HK 1 Operators wishing to carry dangerous goods in aircraft to, from or over the Territory of Hong Kong must obtain prior written permission from the Director of Civil Aviation. Applications must include details of dangerous goods training programmes. Further information may be obtained from the: Director General of Civil Aviation Dangerous Goods Office Airport Standards Division Civil Aviation Department Civil Aviation Department Headquarters Hong Kong International Airport 1 Tung Fai Road Lantau, Hong Kong Telephone: +852 2910 6980/6981/6982 Facsimile: +852 2795 8469	7;1

<i>Identifying code</i>	<i>Variation</i>	<i>Relevant paragraphs</i>
HK 2	English must be used in addition to the language which may be required by the State of Origin, and each language must be given equal prominence.	5;2.5 5;4.1.6.3
HK 3	The shipment by air from Hong Kong of explosive articles and substances originating in Hong Kong is prohibited. Explosives previously imported may be exported by air providing that the classification has been approved by the appropriate authority of the State of Origin or Manufacture.	2;1.5 5;1.1
MO — MACAO SPECIAL ADMINISTRATIVE REGION, CHINA		
≠ MO 1	Operators wishing to carry dangerous goods in aircraft to, from or via Macao, China, must obtain prior written permission from the Civil Aviation Authority — Macao (AACM), China. Further information may be obtained from: Flight Standards Alameda Dr. Carlos D'Assumpção, 336-342 Centro Comercial Cheng Feng, 18º andar Macao, China Tel: (853) 28511213 Fax: (853) 28338089 Email: aacm@aacm.gov.mo Website: www.aacm.gov.mo	7;1
MO 2	Dangerous goods requiring approval under Special Provision A1 or A2 of the Technical Instructions may only be carried on a passenger or cargo aircraft to, from or via Macao with the approval of the Civil Aviation Authority — Macao, China (AACM). Applications for approval must be submitted to the AACM with prescribed form at least ten working days prior to intended flight.	Table 3-1 3;3
DE — GERMANY		
≠ DE 1	Fissile material as specified under 1) and large sources as specified under 2) shall not be accepted for carriage to/from or through Germany without prior permission by the: Bundesamt für Strahlenschutz Postfach 10 01 49 D-38201 Salzgitter, Germany Telephone: 030 18 333 1770 Facsimile: 030 18 333 1705 1) For the purpose of this variation, fissile material (nuclear fuels), as defined in paragraph 2.1 of the German law on atomic energy, are: a) plutonium-239 and plutonium-241; b) uranium enriched with the isotopes uranium-235 or uranium-233; c) any material containing one or more of the materials given in a) and b); and d) materials of such kind as to enable a continuous self-sustaining chain reaction to be maintained in a suitable installation (reactor) and which are defined in a legal degree. Materials (other than solidified high radioactive fission product solutions from reprocessing of nuclear fuels) containing the isotopes uranium-233, uranium-235, plutonium-239 and plutonium-241 in such quantities that the total quantity of all these isotopes is not more than 15 g or the concentration of all these isotopes in total is not greater than 15 g per 100 kg are exempted from this variation and therefore do not need prior permission. 2) A shipment is to be treated as a large source if the activity per package exceeds 1000 TBq.	1;1.2 5;1.2
≠ DE 2	Applications for approval of Type B packages, packages containing fissile material, shipments, special arrangements and notifications should be addressed to:	5;1.2 6;7

<i>Identifying code</i>	<i>Variation</i>	<i>Relevant paragraphs</i>
	Bundesamt für Strahlenschutz Postfach 10 01 49 D-38201 Salzgitter, Germany Telephone: 030 18 333 1770 Facsimile: 030 18 333 1705	
DE 3	Applications for approval of special form radioactive material should be addressed to: Bundesanstalt für Materialforschung und prüfung, Fachgruppe III.3 D-12200 Berlin, Germany Telephone: (030) 8104 1330 Facsimile: (030) 8104 1237	2;7.2.3.3
DE 4	For exemptions to the Technical Instructions the following authority should be contacted for all classes: Luffahrt-Bundesamt, Gruppe Luftverkehrssicherheit Sachgebiet Gefahrgut Kelstarbacher Str. 23 Telephone: (06142) 9461-0 Facsimile: (06142) 9461-59	1;1.1
DE 5	A substance, mixture or solution, liquid or solid, classified as UN 3077 Environmentally hazardous substance, solid, n.o.s. or UN 3082 Environmentally hazardous substance, liquid, n.o.s. by the regulations of other modes of transport must also be transported by air under these entries.	2;0, 2;9
DK — DENMARK		
DK 1	The carriage by aircraft to, from, through or over the territory of the Kingdom of Denmark, including Greenland and the Faroe Islands, of: 1) fissile radioactive material as defined in ICAO Doc 9284, 2;7.1.3 in quantities exceeding the limits set out in 2;7.23.5; and 2) radioactive material: — in a Type B(U) package containing more than 3000 A ₁ or 3000 A ₂ or 1000 TBq, whichever is the lower; or — in a Type B(M) package; or — in a Type C package containing more than 3000 A ₁ or 3000 A ₂ , as appropriate, or 1000 TBq, whichever is the lower; or — as a special arrangement in the sense of the transport regulations; shall not be accepted without prior permission by the Civil Aviation Administration. Applications should be sent to the: National Institute of Radiation Hygiene Knapholm 7 DK-2730 Herlev Telephone: 45.44 54 3454 (Mon.–Fri. 10:00–15:00) Facsimile: 45.44 54 34 50 E-mail: sis@sis.dk	2;7.1.3, 2;7.2.3.5

<i>Identifying code</i>	<i>Variation</i>	<i>Relevant paragraphs</i>
DK 2	<p>National legislation in Denmark specifies that aircraft in the territory over Denmark and Greenland must not, without prior permission from the Danish Transport Authority, carry weapons, explosives, war equipment or munitions.</p> <p>Explosives classified as Class 1.4S according to these Instructions can be carried without prior approval if they are packed and labelled in accordance with the current edition of these Instructions. Explosives must be transported in the cargo hold of the aircraft.</p> <p>Written applications must be forwarded to:</p> <p style="padding-left: 40px;">Danish Transport Authority Trafikstyrelsen Edvard Thomsens Vej 14 2300 KBH S Denmark</p> <p>Applications must be received by the Danish Transport Authority five working days before the actual flight.</p>	<p>1;1.2 2;1 4;3 7;1</p>
DQ — FIJI		
DQ 1	Radioactive material in any quantity may not be transported by aircraft to, from, within or over Fiji without prior permission of the Civil Aviation Authority of the Fiji Islands (CAAFI).	2;7
DQ 2	A person must not handle or offer for transport explosives classified as Class 1 in the ICAO Technical Instructions to, from, within or over Fiji without prior permission of CAAFI. This includes ammunition for sporting weapons, Division 1.4S.	2;1
DQ 3	Infectious substances, including diagnostic specimens or biological products are not permitted in national or international mail to, from, within or over Fiji.	1;2.3
DQ 4	The English language shall be used for marking and labelling any form of dangerous goods documentation transported by air.	5;2.5 5;4.1.6.3
<p>All questions and requests for permission or approval shall be lodged with CAAFI ten days prior to the proposed flight. The correspondence should be addressed to:</p> <p style="padding-left: 40px;">The Civil Aviation Authority of the Fiji Islands (CAAFI) Private Mail Bag NAP 0354 Nadi Airport Fiji Islands Telephone: (679) 672-1555 Facsimile: (679) 672-1500/(679) 672-5125</p>		
ES — SPAIN		
ES 1	In domestic transport and in international transport originating in Spain, Spanish shall be used in all the markings and in the dangerous goods transport document, in addition to the languages required by the States of transit and destination.	5;2.5 5;4.1.6.3
FR — FRANCE		
FR 1	<p>The competent authority for France for the transport of dangerous goods by air is:</p> <p style="padding-left: 40px;">Direction Générale de l'Aviation Civile (DGAC) Direction de la Sécurité de l'Aviation Civile (DSAC) Direction de la Navigabilité et des Opérations (DSAC/NO) 50, rue Henry Farman 75720 PARIS CEDEX 15 FRANCE Telephone: +33.(0)1.58.09.44.80 Facsimile: +33.(0)1.58.09.45.52</p>	

Identifying code	Variation	Relevant paragraphs
	For the issuance of shipment approvals and approvals of package designs or radioactive material for civilian use, the competent authority is the Autorité de Sûreté Nucléaire (ASN), the address of which is given in FR 2.	
FR 2	<p>All questions relating to the transport by air of radioactive and fissile materials for civilian use should be directed, in accordance with the instructions contained in the variation concerned, to DGAC, ASN and DSC/COGIC.:</p> <p>Direction Générale de l'Aviation Civile (DGAC) Direction de la Sécurité de l'Aviation Civile (DSAC) – Direction de la Navigabilité et des Opérations (DSAC/NO) Mission Marchandises Dangereuses (DSAC/NO-MD) 50, rue Henry Farman 75720 PARIS CEDEX 15 FRANCE Telephone: +(33).(0)1.58.09.49.70 Facsimile: +(33).(0)1.58.09.45.52</p> <p>Autorité de Sûreté Nucléaire (ASN) Direction des activités Industrielles et du Transport 10, Route du panorama Robert Schuman 92266 FONTENAY AUX ROSES CEDEX FRANCE Telephone: +(33).(0)1.43.19.70.39 Facsimile: +(33).(0)1.43.19.70.27</p> <p>Direction de la Sécurité Civiles (DSC) Centre Opérationnel de Gestion Interministérielle des Crises (COGIC) 87-95 Quai du Docteur Dervaux 92600 ASNIERES FRANCE Telephone: +(33).(0)1.56.04.72.40 Facsimile: +(33).(0)1.41.11.52.52</p>	1;1.2 5;1.2
FR 3	<p>Transport by air of the following radioactive material to, from, through or over French territory cannot be performed without a permit issued by ASN:</p> <ul style="list-style-type: none"> — in the case of radioactive material in special form, if the activity transported in the package is higher than or equal to 3000 A₁, or 100000 A₂, if the latter value is lower than the 3000 A₁ value; — in the case of all other radioactive material, if the activity transported is higher than or equal to 3000 A₂. <p>Once a permit has been issued, DGAC and DSC/COGIC must be advised of the shipment at least 48 hours in advance.</p>	5;1.2 7;1.1
FR 4	<p>An aircraft whose internal surfaces have been contaminated by radioactive material may be reused on French territory only after approval by an authorized expert. ASN must be consulted on the selection of the expert. Such approval must be entered in the maintenance log of the aircraft. DGAC must be advised of such contamination and approval before the aircraft is reused.</p>	7;3
FR 5	<p>A written report on any incident/accident occurring in the territory of France involving a package of radioactive material (Class 7) must be sent by the operator (or a representative) within 48 hours to the Autorité de Sûreté Nucléaire (ASN) (see FR 2), with a copy to the DGAC, in full compliance with the guide on procedures for reporting events of radioactive material available on its website (www.asn.fr).</p> <p>These requirements also apply to:</p> <ul style="list-style-type: none"> — ground handling agents at the airport acting on behalf of the operator; — any entity responsible for the loading/unloading of dangerous goods; and — any entity responsible for the handling and storage of dangerous goods at the airport <p>in French territory.</p>	7;4

<i>Identifying code</i>	<i>Variation</i>	<i>Relevant paragraphs</i>
FR 6	<p>With respect to the transport by air of dangerous goods listed in paragraph 1;2.3.2, the competent authority from France (FR 1) has notified the following instructions:</p> <ul style="list-style-type: none"> a) dangerous goods as described in sub-paragraphs a), b) and c) are not permitted for transport in airmail to, from, or transiting through France; and b) dangerous goods as described in sub-paragraphs d) and e) are permitted for transport in airmail to or transiting through France only if they are from a State that has issued a formal approval to its designated postal operator. <p>The transport of radioactive material by national post referred to in Part 1;2.3.2 c) of these Instructions is subject to the shipper obtaining an approval from the competent authority (ASN) (see FR 3).</p>	1;2.3
FR 7	<p>The emergency response information described below must appear on shipments of dangerous goods to, from, within or transiting through France. This provision does not apply to the transport of magnetized material or dangerous goods for which no transport document is required.</p> <p>Telephone number</p> <ul style="list-style-type: none"> — The transport document required under the ICAO Technical Instructions must contain a telephone number by means of which emergency response information can be obtained in case of an incident and/or accident involving the dangerous goods being transported. — This telephone number must be available 24 hours a day and must include the regional codes and, for international numbers outside France, the country and city codes needed to complete the call from France. — This telephone number must be monitored at all times by a person who: <ul style="list-style-type: none"> — is knowledgeable concerning the hazards and characteristics of the dangerous goods being transported; — has comprehensive emergency response and accident mitigation information for the dangerous goods; and — can immediately call upon a person who possesses such knowledge and information. 	5;4
FR 8	Not used.	
FR 9	Not used.	
GB — UNITED KINGDOM		
GB 1	National regulations require that most explosives which are to be imported be classified before they are brought into the United Kingdom, by HM Explosives Inspectorate of the Health and Safety Executive or the Explosives Storage and Transport Committee. It is the responsibility of the importer to obtain the classification. Explosives manufactured in the United Kingdom are required to have been classified before they are transported.	2;1.5 5;1.1
GB 2	<p>The following requirements apply to aircraft registered:</p> <ul style="list-style-type: none"> a) in the United Kingdom no matter where they are operating; and b) in a State other than the United Kingdom and which are not required to operate under and in accordance with Annex III to Regulation (EC) NO. 3922/1991 ("EU-OPS"), when they are operating in the United Kingdom: <p>Aircraft may only carry dangerous goods with the prior approval of the Civil Aviation Authority. Carriage of such goods must be in compliance with these Instructions. Application for permission should be made at least ten working days before the date of the first flight on which dangerous goods are to be carried and should be submitted to:</p>	1;1.2

Identifying code	Variation	Relevant paragraphs
	Dangerous Goods Office Civil Aviation Authority 1W, Aviation House Gatwick Airport South West Sussex RH6 0YR Telephone: 01293 573800 Facsimile: 01293 573991 E-mail: dgo@caa.co.uk	
	EU-OPS aircraft	
	Aircraft registered in a State other than the United Kingdom and which are required to operate under and in accordance with EU-OPS do not require the approval of the Civil Aviation Authority providing an approval granted by such a State is held.	
GB 4	For the purposes of compliance with 7;4.7, notification of dangerous goods on an aircraft involved in an aircraft accident or serious incident or other incident in the United Kingdom should be sent by the quickest means possible to: <p data-bbox="370 783 1284 947"> Dangerous Goods Office Civil Aviation Authority 1W, Aviation House Gatwick Airport South West Sussex, RH6 0YR Telephone: + 44 (0)1293-573800, for notifications Monday to Friday between the hours of 0900 and 1700 UK time, or + 44 (0)1293-567171, at all other times. </p> This notification is in addition to, and not instead of, that required under Annex 13.	7;4.7
GB 5	Biological substances, Category B (UN 3373) are not permitted in international mail either to or from the United Kingdom. Biological substances, Category B (UN 3373) are not permitted in domestic mail except under special arrangements. Exempt patient specimens are not permitted in international or domestic mail except under special arrangements.	1;2.3
GB 6	When any operator intends to overfly the United Kingdom carrying any package containing radioactive material with an activity greater than: (a) for special form 3000 A ₁ or 100000 A ₂ , whichever is the lower; or (b) for all other radioactive material 3000 A ₂ , it must notify the Dangerous Goods Office (contact details as in GB 2) at least two working days before the expected date of the flight, providing the information required by 5;1.2.1.4 d), together with the names and addresses of the shipper and consignee, and the contact details for the operator. If the flight does not take place as planned, or if there are any changes in the information provided, the Dangerous Goods Office must be notified immediately. The operator is not required to wait for any acknowledgement or acceptance before carrying out the flight.	
GB 7	In accordance with 1;4.1.2, national regulations require the following dangerous goods training programmes to be subject to review and approval by the Civil Aviation Authority: <ul data-bbox="370 1430 1284 1619" style="list-style-type: none"> — operators of aircraft registered in the United Kingdom; — non-United Kingdom operators that provide dangerous goods training to their own staff in order for them to carry out dangerous goods acceptance checks on behalf of other operators; — handling agents that provide dangerous goods training to their own staff in order for them to carry out dangerous goods acceptance checks on behalf of operators; and — companies that provide dangerous goods training to other companies employing categories of personnel identified in Table 1-4, column 1, 2, 3 or 6. 	
	Details of the approval requirements can be found in CAP 483, available free of charge from the following website: www.caa.co.uk/publications .	

Identifying code	Variation	Relevant paragraphs
HR — CROATIA		
HR 1	<p>The competent national authority in the Republic of Croatia for Annex 18 and these Instructions is:</p> <p>Croatian Civil Aviation Agency (CCAA) Ulica grada Vukovara 284 10 000 Zagreb, Croatia Telephone: +385 1 2369 300 Facsimile: +385 1 2369 301 Email: ccaa@ccaa.hr Website: www.ccaa.hr</p>	
HR 2	<p>The following requirements apply to aircraft registered:</p> <ul style="list-style-type: none"> — in the Republic of Croatia no matter where they are operating; — in a State other than the Republic of Croatia which is not required to operate under and in accordance with Annex III to Regulation (EC) NO. 3922/1991 ("EU-OPS") when they are operating in the Republic of Croatia. <p>Aircraft may only carry dangerous goods with prior approval of the Croatian Civil Aviation Agency (CCAA). Carriage of such goods must be in compliance with the latest effective edition of these Instructions and any addenda or corrigenda published.</p> <p>Operators (AOC holders) whose head office is located in the European Union and who are required to operate under and in accordance with Annex III to Regulation (EC) No. 3922/1991 ("EU-OPS") do not require the approval of the Croatian Civil Aviation Agency, provided an approval granted by such a State is held.</p>	1;1.2
HR 3	<p>Dangerous goods requiring approval under Special Provisions A1 or A2 of these Instructions or other State exemptions or approvals may only be carried on a passenger or cargo aircraft in Croatian territory with the approval of the Croatian Civil Aviation Agency (CCAA). Applications for approval must be lodged with the CCAA at least ten days prior to the proposed flight.</p>	1;1.1 Table 3-1 3;3
HR 4	<p>According to the Act on Radiological and Nuclear Safety (Official Gazette No. 28/10), for transportation of radioactive materials to and from the Republic of Croatia, the operator must ensure that the consignor/consignee is in possession of a prior approval. Application for prior approval may be addressed to:</p> <p>State Office for Radiological and Nuclear Safety (SORNS) Frankopanska 11 10 000 Zagreb, Croatia Telephone: +385 1 4881 770 Facsimile: +385 1 4881 780 Email: dzrns@dzrns.hr Website: www.dzrns.hr</p>	1;1.2 5;1.2 7;1
HR 5	<p>According to the Explosive Substances Act (Official Gazette No. 178/04, 109/07, 67/08 and 144/10), for transportation of explosives to and from the Republic of Croatia, the operator must ensure that the consignor/consignee is in possession of a prior approval. Application for prior approval may be addressed to:</p> <p>Ministry of Interior Administrative and Inspection Authority 10 000 Zagreb Ilica 335 Telephone: +385 1 3788 646 Facsimile: +385 1 3788 187 Email: pitanja@mup.hr Website: www.mup.hr</p>	1;1.2 2;1 4;3 7;1

<i>Identifying code</i>	<i>Variation</i>	<i>Relevant paragraphs</i>
IN — INDIA		
IN 1	Dangerous goods may be carried to/from/within/over India provided that the operator is certified by the State of the operator to carry such goods and also that all the requirements specified in the ICAO Technical Instructions are complied with.	1;1 7;1
IN 2	For transportation of radioactive materials to/from/within India (not over India), the operator must ensure that the consignor/consignee is in possession of authorization issued by the Government of India in pursuance of Section 16 of the Atomic Energy Act, 1962. Application for permission for carriage of radioactive material may be addressed to: Atomic Energy Regulatory Board Radiological Safety Division Niyamak Bhavan Anushaktinagar Mumbai — 400 094 India	5;1 7;1
IN 3	For carriage of arms, ammunition and munitions of war, etc., to, from or over India, written permission under rule 8 of the Aircraft Rules, 1937, shall be required. Application for such permission may be addressed to: Director General of Civil Aviation Opp. Safdarjung Airport New Delhi — 110 003 India	5;1 7;1
IR — ISLAMIC REPUBLIC OF IRAN		
IR 1	The importation of radioactive material into the Islamic Republic of Iran is subject to prior permission from the Atomic Energy Organization of the Islamic Republic of Iran. Any request concerning the applicability of this variation must be addressed to: Atomic Energy Organization of the Islamic Republic of Iran Nuclear Safety and Radiation Protection Management P.O. Box 14155 — 4494 Tehran, Islamic Republic of Iran Telephone: +98 21 88 22 11 24 +98 21 82 06 35 74 Facsimile: +98 21 88 22 11 25	1;1.1 5;1.2 7;1.1
IR 2	In addition to the application of the regulations described in Table 7-1, packages containing Division 6.1 from Class 8 and Division 4.1 from Division 4.3 must be separated from each other.	7;1 7;2
IR 3	Dangerous goods which are principally forbidden for air transport and are subjected to Special Provision A1 or A2 of the Technical Instructions may be imported into the Islamic Republic of Iran subject to prior permission from the Civil Aviation Organization of Iran. Application for permission must be made at least fifteen days prior to the proposed flight date and must be addressed to: Vice President C.A.O.I.R. of Iran Deputy of Flight Standard Civil Aviation Organization Mehrabad International Airport Tehran, Islamic Republic of Iran Facsimile: +98 21 66 03 65 52	Table 3-1 3;3
IR 4	Fissile material in quantities exceeding quantities for fissile excepted must not be transported by aircraft to, from, or through the Islamic Republic of Iran without prior permission from: Iranian Nuclear Regulatory Authority (INRA) End of North Kargar St. P.O.Box 14155-1339 Tehran, Islamic Republic of Iran Telephone: +98 21 88 22 10 73 Facsimile: +98 21 88 22 10 72 Email: INRA@aeoi.org.ir	2;7 4;9 5;1 5;2 6;7 7;1 7;2

Identifying code	Variation	Relevant paragraphs
IT — ITALY		
IT 1	<p>The transport of radioactive and fissile material to/from/through Italian territory can be performed by authorized carriers only. Application for authorization can be made at the following address:</p> <p>Ministero dello Sviluppo Economico Dipartimento per l'Energia Direzione Generale per l'Energia Nucleare, le Energie Rinnovabili e l'Efficienza Energetica Divisione V — Attività afferenti la fonte primaria nucleare Via Molise, 2 00187 Roma — Italy Telephone: +39 06 4705 2705/2103 Facsimile: +39 064788 7976 E-mail: dgerm.ufficiob6trasporti@sviluppoeconomico.gov.it</p>	1;1.1 5;1.2 7;1
IT 2	<p>Prior approval is requested for shipments of:</p> <ul style="list-style-type: none"> — Type B (M) packages; — Fissile packages; and — Type B (U) packages containing radioactive material with activity greater than 3000 A₁ or 3000 A₂ as appropriate or 1000 TBq, whichever is the lower. <p>Beyond the approval, such shipments must be notified at least 48 hours in advance to ISPRA. Application for shipment approval and notification can be made at the following address:</p> <p>Instituto Superiore per la Protezione e la Ricerca Ambientale (ISPRA) Institute for Environmental Protection and Research Department of Nuclear, Technological and Industrial Risk Radioactive Material Transport Division Via Vitaliano Brancati, 48 00144 Rome — Italy Telephone: +39 06 5007 2978 Facsimile: +39 06 5007 2941 E-mail: trasporti@isprambiente.it</p>	5;1.2.1
IT 3	<p>Application for approval of special form radioactive material, Type B and Type C packages, packages containing fissile material should be addressed to:</p> <p>Instituto Superiore per la Protezione e la Ricerca Ambientale (ISPRA) Institute for Environmental Protection and Research Department of Nuclear, Technological and Industrial Risk Radioactive Material Transport Division Via Vitaliano Brancati, 48 00144 Rome — Italy Telephone: +39 06 5007 2978 Facsimile: +39 06 5007 2941 E-mail: trasporti@isprambiente.it</p>	5;1.2.1
IT 4	<p>Further utilization of an aircraft having undergone radioactive contamination must be certified by a qualified expert and registered on the efficiency technical book.</p>	7;3.2
IT 5	<p>The transport of arms, ammunitions and explosives to/from/through Italian territory must previously be authorized by:</p> <p>Ente nazionale per l'Aviazione Civile (ENAC) Direzione Regolazione Trasporto Aereo Viale Castro Pretorio, 118 00185 Rome — Italy Telephone: +39 06 44596404 Facsimile: +39 06 44596531 E-mail: regolazione.trasportoaereo@enac.gov.it</p>	1;1 5;1.1 7;1

Identifying code	Variation	Relevant paragraphs
IT 7	<p>The transport of dangerous goods in portable tanks is subject to prior approval of the shipment by the Italian Competent Authority. Application for the approval, together with a safety analysis, must be made at the following address:</p> <p>Ente nazionale per l'Aviazione Civile (ENAC) Direzione Regolazione Trasporto Aereo Viale Castro Pretorio, 118 00185 Rome — Italy Telephone: +39 06 44596404 Facsimile: +39 06 44596531 E-mail: regolazione.trasportoaereo@enac.gov.it</p>	
JM — JAMAICA		
JM 1	<p>Applications for approval to transport dangerous goods under Special Provision A1 or A2 and exemption applications must be directed to:</p> <p>The Director General Jamaica Civil Aviation Authority 4 Winchester Road Kingston 10 Jamaica, West Indies</p>	3;3
JM 2	<p>On shipments to, from, within or transiting through Jamaica, emergency response information, as described in JM-3, must be provided for all dangerous goods other than magnetized material and dangerous goods for which no Transport Document is required.</p>	5;4
JM 3	<p><i>Emergency Response Information.</i> The Transport Document required by these Technical Instructions must include a 24-hour emergency response telephone number (including all area codes, and for international numbers for locations outside Jamaica, the international access code and country and city codes needed to complete the call from within Jamaica). The number must be monitored by an individual who:</p> <ul style="list-style-type: none"> — speaks English fluently; — is knowledgeable of the hazards and characteristics of the dangerous good(s) being transported; — has comprehensive emergency response and accident mitigation information for the dangerous good(s); — has immediate access to a person who possesses such knowledge and information. 	5;4
JM 4	<p>Transport of dangerous goods by air must be in accordance with the current edition of the ICAO <i>Technical Instructions for the Safe Transport of Dangerous Goods by Air</i> (Doc 9284). Failure to comply with the Technical Instructions is a violation of the Jamaica Civil Aviation Regulations, 2004.</p>	
JP — JAPAN		
JP 2	<p>The maximum radiation level at any point on any external surface of packages, overpacks or freight containers containing radioactive material must not exceed 2 mSv/h even if those are transported under exclusive use.</p>	4;9.1 5;1
JP 3	<p>“Excepted radioactive material” must not contain pyrophoric (liquid) or explosive radioactive material.</p>	1;6.1.5
JP 8	<p>All Type B(U) and Type B(M) packages, and packages containing 0.1 kg or more of uranium hexafluoride require both packages design approvals and shipment approvals of the appropriate authorities of Japan.</p>	5;1.2 6;7.5 6;7
JP 9	<p>The labels shall be affixed to two opposite sides of the outside of the unit load device containing radioactive material.</p>	7;2.8
JP 10	<p>“Excepted radioactive material” must not be carried in the cabin or cockpit of an aircraft.</p>	7;2.1
≠	<p>JP 11 Radioactive material (Class 7), except for “Excepted radioactive material” must not be stowed in the same cargo compartment together with packages containing explosives (Class 1 except for Compatibility Group S).</p>	7;2.2
JP 12	<p>Handling and loading of radioactive material must be made in such a manner that no person other than ground handling and loading staff can have access to the area.</p>	7;2.9

<i>Identifying code</i>	<i>Variation</i>	<i>Relevant paragraphs</i>
JP 17	The maximum radiation level at a distance of 1 m from the external surfaces of packages, overpacks or freight containers containing radioactive material must not exceed 0.1 mSv/h, except when overpacks or freight containers are transported under exclusive use with prior notification to the Civil Aviation Bureau of Japan.	4;9.1 5;1
JP 20	Not used.	
JP 21	Not used.	
JP 23	Radioactive material of Class 7 in excepted packages with an associated risk of another class specified in 3;5 must be subject to the provisions of 1;6.1.5, 3;5 and to the variations JP 3 and JP 9.	1;6 3;5
≠ JP 24	Any substance bearing "Toxic" label or "Toxic Gas" label must not be packed in the same outer packaging with foodstuffs, feed or other edible substances intended for consumption by humans or animals.	4;1
JP 26	Neither packages containing fissile material nor packages having greater radioactivity than the following values shall be transported by air within the territorial airspace of Japan: 1) for special form radioactive material — 3000 A ₁ or 100000 A ₂ , whichever is the lower; or 2) for all other radioactive material — 3000 A ₂ .	2;7.2
KG — KYRGYZ REPUBLIC		
KG 1	Radioactive material in any quantity may not be transported by aircraft to, from, within or over the Kyrgyz Republic without prior permission of the Civil Aviation Authority of the Kyrgyz Republic (CAAKR).	2;7
KG 2	A person must not handle or offer for transport explosives classified as Class 1 to, from, within or over the Kyrgyz Republic without prior permission of the Civil Aviation Authority of the Kyrgyz Republic (CAAKR).	2;1
KG 3	All requests for permission or approval must be lodged with the Civil Aviation Authority of the Kyrgyz Republic (CAAKR) eight days prior to the proposed flight and be addressed to: Civil Aviation Authority Ministry of Transport and Communications Kyrgyz Republic 1, Ajibek Batyra st., Bishkek, 720044 Telephone: +996 (312) 542140, 542141, 542135 Facsimile: +996 (312) 542140, 542141, 542135	
+ KH — CAMBODIA		
KH 1	Operators wishing to carry dangerous goods in aircraft to/from or via the Kingdom of Cambodia must obtain prior written approval from the State Secretariat of Civil Aviation. Applications must be made on prescribed forms which can be obtained from the State Secretariat of Civil Aviation. They must be addressed to: Secretary of State State Secretariat of Civil Aviation No. 62, Preah Norodom Blvd., Phnom Penh Kingdom of Cambodia cc: Air Transport Department	1;1

<i>Identifying code</i>	<i>Variation</i>	<i>Relevant paragraphs</i>
KP — DEMOCRATIC PEOPLE'S REPUBLIC OF KOREA		
KP 1	The Flight Safety Standard Department of General Administration of Civil Aviation of the Democratic People's Republic of Korea is responsible for ensuring compliance with Annex 18 and the Technical Instructions in the Democratic People's Republic of Korea. E-mail: gaca@sillibank.com Facsimile: +850 2 381 4625	
KP 2	Dangerous goods requiring exemption or approval under Special Provision A1 or A2 of the Technical Instructions may be carried on a passenger or cargo aircraft to/from/over the Democratic People's Republic of Korea only with the permission of the Flight Safety Standard Department. Applications for permission for this purpose should be submitted at least ten working days prior to the intended flight.	3;3 Table 3-1
KP 3	A dangerous goods incident or accident is to be notified to the Flight Safety Standard Department of General Administration of Civil Aviation as soon as practically available, but within five working days.	7;4.4
LU — LUXEMBOURG		
LU 1	Under the Grand-ducal regulation of 14 December 2000 concerning the protection of the population against the dangers arising from ionizing radiation, as modified on 21 July 2006, each airline carrying radioactive material above exemption level (excepted packages, Type A, Type B, etc.) to and from the airport of Luxembourg must be authorized to this effect by the Minister of Health. Information on the licensing procedure can be obtained at: Division de la Radioprotection Allée Marconi — Villa Louvigny L-2120 Luxembourg E-mail: radioprotection@ms.etat.lu Telephone: +352 247 85670 www.radioprotection.lu	
MY — MALAYSIA		
MY 1	Operators wishing to carry all classes of dangerous goods from, over or to the territory of Malaysia must obtain prior written permission from the Director General, Department of Civil Aviation, Malaysia. Request for approval should be addressed to: The Director General Department of Civil Aviation, Malaysia Level 1-4, Block Podium Lot 4G4, Precinct 4 Federal Government Administrative Centre 62570 Putrajaya, Malaysia. AFTN: WMKKYAYX Tel: 603-8871 4000 Fax: 603-8889 5691	
MY 2	The transport of radioactive material by air to or from Malaysia will be considered for approval by the Director General, Department of Civil Aviation, Malaysia, provided prior permit or approval from the Atomic Energy Licensing Board of Malaysia has been obtained. Application for a permit or approval from the Atomic Energy Licensing Board of Malaysia can be made at the following address: The Atomic Energy Licensing Board of Malaysia Ministry of Science, Technology and Innovation Batu 24, Jalan Dengkil 43800 Dengkil, Selangor Tel: 03-8928 4100 03-8926 7699 Fax: 03-8922 3685	5;1 7;1

Identifying code	Variation	Relevant paragraphs
MY 3	Individual shippers wishing to transport arms, ammunition and explosives to or from Malaysian territory must first obtain a permit from the Inspector General of Police, Malaysia. Having obtained the permit from the Inspector General of Police, Malaysia, shippers then should forward their application to the Director General, Department of Civil Aviation, Malaysia for approval to carry arms, ammunition and explosives by air.	5;1
MY 4	If an in-flight emergency occurs within Malaysian airspace the pilot-in-command must inform the appropriate air traffic services unit, for the information of aerodrome authorities, of any dangerous goods on board the aircraft. The information must include the primary hazard, subsidiary risks for which labels are required and the quantity and location aboard the aircraft of the dangerous goods. If the situation permits, the information should also include the proper shipping name, class or division, and in the case of Class 1, the compatibility group.	7;4.3
MY 5	An operator who is involved in a dangerous goods incident in Malaysian territory must provide the Malaysian Authority with information required to minimize hazards created by any spillage, leakage of fluid or radiation, breakage, or other damage to dangerous goods.	7;4.4
MY 6	English must be used in addition to the language which may be requested by the State of Origin and each language must be given equal prominence.	5;2.5 5;4.1.6.3
NL — NETHERLANDS		
NL 1	Dangerous goods requiring approval under Special Provision A1 or A2 of these Instructions, may not be transported on a passenger aircraft or cargo aircraft (as appropriate) to, from or through the Netherlands without prior approval of the Ministry of Transport, Public Works and Water Management, irrespective of whether or not the Netherlands is the State of Origin. Application for all approvals should be made at least 10 days prior to the proposed flight date and must be submitted to: Human Environment and Transport Inspectorate (CAA — NL) Ministry of Infrastructure and the Environment Certification and Approvals Department Postbus 575 2130 AN Hoofddorp The Netherlands Telephone: +31 70 456 3003 +31 88 489 0000 (outside office hours) Facsimile: +31 70 456 3030 Email: dgmelding@ilent.nl	Table 3-1 3-3
NL 2	Not used.	
NL 3	Consignments containing more than 15 g unirradiated uranium-235, or uranium-233 or plutonium unless the content of Pu-238 is more than 80% by mass, or uranium enriched to 20% uranium-235 or more, or more than 1 kg uranium enriched to 10% uranium-235 but less than 20%, or 10 kg enriched uranium enriched above natural but not more than 10%, or irradiated fissile material shall not be accepted for carriage to, from, through or over the Netherlands without written permission by the Ministry of Housing, Spatial Planning and the Environment. Consignments containing uranium, plutonium and thorium with concentrations of 0.1%, 0.1% and 3% by mass respectively and exceeding the exemption limits of Table 2-15 shall not be accepted for carriage to, through or from the Netherlands without written permission. Consignments of consumer goods containing added radioactivity exceeding the exemption levels of Table 2-15, or medicinal products containing added radioactivity shall not be accepted for carriage to or from the Netherlands without written permission. Consignments containing other radioactive material exceeding the exemption limits of Table 2-15 shall not be accepted for carriage to, through or from the Netherlands without prior notification. Notification may be done by the shipper, consignee, operator or other party, but must be verified by the operator. The operator is not required to wait for any acknowledgement or acceptance before carrying out the flight. <i>Note.— Written permission for transport to, from or through the Netherlands may be obtained by the shipper, consignee, operator or other party, but must be verified by the operator at time of acceptance.</i>	1;2.7 5;1.2 7;1

Identifying code	Variation	Relevant paragraphs
	<p>Applications for permits or notifications should be addressed to:</p> <p>SenterNovem Team stralingsbescherming P.O. Box 3144 2509 AC The Hague The Netherlands Telephone: +31 70 373 5000 Facsimile: +31 70 373 5100</p>	
NL 4	<p>Any substance, liquid or solid solutions and mixtures (such as preparations and wastes), which cannot be classified in the other classes and that meet the criteria for substances pollutant to the aquatic environment as described in the European Agreement concerning the international carriage of dangerous goods by road (ADR), are to be assigned as Class 9 — miscellaneous dangerous goods “Environmentally hazardous substance, liquid, n.o.s.” or “Environmentally hazardous substance, solid, n.o.s.”.</p> <p>This variation does only apply in case of connecting road transport to, through or from the Netherlands. This variation does not apply to transit and overflights.</p>	2;0 2;9
NL 5	Not used.	
NL 6	<p>National legislation in the Netherlands specifies that an operator shall not carry dangerous goods without the prior permission of the Civil Aviation Authority in the Netherlands (CAA-NL) and that when such goods are carried, it must be in compliance with the Technical Instructions. This applies to operators carrying dangerous goods to and from the Netherlands (excluding overflight). Permission is provided by the issuance of a dangerous goods licence to the operator and it will only be provided if the operator is in the possession of staff who received training in accordance with the provisions in the Technical Instructions. Operators registered in the Netherlands and in a State other than the Netherlands which are required to operate under and in accordance with EU-OPS do not require permission of the Civil Aviation Authority of the Netherlands providing the permission granted by such a State is held.</p> <p>Application for a dangerous goods licence must be made at least six weeks before the date of the first flight on which dangerous goods are to be carried. An application form is available from:</p> <p>Human Environment and Transport Inspectorate (CAA — NL) Ministry of Infrastructure and the Environment Certification and Approvals Department Postbus 575 2130 AN Hoofddorp The Netherlands Telephone: +31 70 456 3003 +31 88 489 0000 (outside office hours) Facsimile: +31 70 456 3030 Email: dgmelding@ilent.nl</p>	1;1.2
	OM — OMAN	
OM 1	<p>It is prohibited to transport dangerous goods to/from/over Oman except with the prior permission of the civil aviation authority after coordination with the competent authorities in accordance with the applicable rules and, in particular:</p> <ol style="list-style-type: none"> explosives, weapons and war ammunition; nuclear goods, radioactive isotopes, poisonous gases and related objects; goods of dual use, like drugs; germs and dangerous goods; and any other goods requiring approval under Special Provision A1 or A2. 	

<i>Identifying code</i>	<i>Variation</i>	<i>Relevant paragraphs</i>
	Application for approval must be made at least five days prior to the proposed flight date and must be submitted to: Director Flight Safety Directorate General of Safety and Aviation Services P.O. Box 1 P.C. 111 Muscat International Airport Sultanate of Oman	
+	PE — PERU	
PE 1	Part 110, paragraph 110.5(h) of the Peruvian Aviation Regulations currently in force states that all air shipments of explosives including loads in transit must have a written authorization or exemption issued by the DGCA, as appropriate. Paragraph 110.5(i) sets out the requirements for the granting of authorizations and exemptions.	2;1
PE 2	All shipments of dangerous goods that qualify as controlled products or chemical inputs by the terms of Law 28305 on Controlled Products and Chemical Inputs of Peru must comply with the provisions of said law.	
PE 3	Part 110, paragraph 110.37(d) of the Peruvian Aviation Regulations currently in force states that shippers offering dangerous goods for loading onto an aircraft must provide the air operator with copies of the safety information sheets for the goods to be shipped.	5;4
	PK — PAKISTAN	
PK 1	The English language must be used for marking of packages and overpacks. However, if the language of the State of Origin is to be used, both these languages must be written side by side with prominent effect.	5;2.5
PK 2	A brief text indicating the nature of the risk involved must appear in English on all hazard labels.	5;3
PK 3	While English must be used in addition to the language of the State of Origin for the dangerous goods transport document, the document itself is to conform to the IATA type shipper's declaration.	5;4
	PL — POLAND	
PL 1	Transport of spent nuclear fuel or radioactive waste to, from, through or over the territory of Poland shall not be accepted without permission by the President of the Civil Aviation Office (CAO) after consultation with the President of the National Atomic Energy Agency. Every correspondence should be sent to the President of the CAO no later than thirty working days before planned flight. The applications should be addressed to: President of Civil Aviation Office Żelazna 59 Street 00-848 Warsaw Poland	7;1
	RO — ROMANIA	
RO 1	In accordance with Romanian legislation, all flights within the Bucharest FIR of civil aircraft carrying cargo consisting of weapons, ammunition, explosives, radioactive materials and other materials classified and regulated as dangerous goods can be performed only after obtaining a permit from the Ministry of Transport and Infrastructure.	1;1.2 Part 2 5;1.2

Identifying code	Variation	Relevant paragraphs
	<p>The application for the above-mentioned permit has to be registered with the Romanian Civil Aeronautical Authority at the following address:</p> <p>Romanian Civil Aeronautical Authority (RCAA) Overflight Department Sos. Bucuresti-Ploiesti, Nr. 38-40 Sector 1, Cod 013695 Bucuresti, Romania Telephone: +40 21 208 15 00 Facsimile: +40 21 208 15 83 AFTN: LRBBYR SITA: BUHTOYA Email: overflight@caa.ro</p> <p>Romanian AIP section GEN 1.2 contains all details regarding the application form and other required specific documents.</p> <p>In case the consignment contains radioactive materials, the air operator must provide to the Romanian Civil Aeronautical Authority a copy of the authorization issued by the National Commission for the Control of Nuclear Activities (CNCAN).</p> <p>The contact information of the National Commission for the Control of the Nuclear Activities is as follows:</p> <p>National Commission for the Control of the Nuclear Activities B-dul. Libertatii, Nr. 14, Sector 5 Bucuresti, Romania Telephone: +40 21 316 05 72 Facsimile: +40 21 317 38 87</p>	
RO 2	<p>RO 1 does not apply in cases of air carriers performing medical emergency flights and in cases of flights by air carriers detaining an operator licence in accordance with EU Regulation No. 1008/2008 and which do not carry dangerous goods classified as:</p> <ul style="list-style-type: none"> — Class 1 — all items; — Class 3 — only desensitized explosives UN 1204, UN 2059, UN 3064, UN 3343, UN 3357 and UN 3379; — Class 6 — only Division 6.2, Category A, UN 2814 and UN 2900 — Class 7 — all items <p>Such carriers must only notify the Romanian Civil Aeronautical Authority before starting the flight with the following information: proper shipping name, UN number, class or division, and quantity.</p>	1;1.2 Part 2
RO 3	<p>Civil aircraft involved in the carriage of dangerous goods that are forbidden for air transport under normal circumstances, in accordance with the ICAO documents, are not permitted to perform flights within the Bucharest FIR (OMTCT 2066/2006).</p> <p>Waivers from the provisions may be granted by the Romanian Civil Aeronautical Authority only if the respective transport is justified by a major public interest. Such a waiver must be granted with the approval of the Ministry of Transport and Infrastructure.</p>	1;1.1.3 Table 3-1
RO 4	Not used.	
RU — RUSSIAN FEDERATION		
RU 1	For all domestic transports in the Russian Federation, the Russian language must be used for all dangerous goods markings and transport documents. For international transports originating in the Russian Federation, Russian and English must be used for dangerous goods markings and transport documents in addition to the languages required by the States of transit and destination.	5;2.5 5;4

<i>Identifying code</i>	<i>Variation</i>	<i>Relevant paragraphs</i>
RU 2	An operator planning to transport high consequence dangerous goods indicated in Table 1-7 of the Technical Instructions to, from, within or through the territory of the Russian Federation shall not accept such goods for transport without receiving confirmation from the airport (or from the ground handling agent) that such goods can be handled in the territory of the Russian Federation, as well as confirmation of the consignee's preparedness to accept such goods (if the goods are transported to the territory of the Russian Federation).	1;5 7;1
RU 3	Fissile radioactive material in any quantity shall not be accepted in the Russian Federation for carriage on passenger aircraft, and shall not be transported into the Russian Federation, from its territory or through its territory without prior permission from: Federal Environmental, Technological and Atomic Supervisory Body (ROSTECHNADZOR) Ul. Taganskaya, 34 109147 Moscow Russia Telephone: 495-411-60-22 Facsimile: 495-261-60-43 This variation covers fissile radioactive material and articles thereof containing uranium-233, uranium-235, plutonium and other isotopes of transuranic elements.	
SA — SAUDI ARABIA		
SA 1	The transport of alcoholic beverages for delivery to any destination in Saudi Arabia is forbidden.	
SA 2	The shipper of any dangerous goods must provide a written undertaking to re-ship the consignment at the shipper's cost and risk if the shipment is not cleared and received by the consignee within 15 working days from the arrival of the consignment at any destination in Saudi Arabia.	
SA 3	The name, address and telephone number of the consignee must be written in full on the air waybill for dangerous goods being shipped to any destination in Saudi Arabia.	
SA 4	Prior permission is required from the concerned government departments for the importation of the following: a) explosives and munitions of war, which require further approval from: Presidency of Civil Aviation Air Transport Department P.O. Box 887 Jeddah 21421 Saudi Arabia b) chemical products, except for perfumery products, cosmetics and dry ice; c) radioactive material. The final destination of radioactive material must be Jeddah, Riyadh or Dammam only, except those for medical purposes, which may be imported to any point in Saudi Arabia.	
SA 5	The final destination for radioactive material must be Jeddah, Riyadh or Damman only, except those intended for medical purposes which may be shipped anywhere in Saudi Arabia as long as this intent is indicated on the shipper's declaration.	
SA 6	The name, address and telephone number of the consignee must be written in full on each package of dangerous goods being shipped to any destination in Saudi Arabia.	
SG — SINGAPORE		
SG 1	In accordance with paragraph 50D of the Singapore Air Navigation Order, air operators wishing to carry dangerous goods into, transiting, or out of Singapore must obtain a dangerous goods permit from the Civil Aviation Authority of Singapore (CAAS). Information and application forms for dangerous goods permits may be obtained from the CAAS website (www.caas.gov.sg). All applications are to be made on prescribed forms and addressed to:	7;1

Identifying code	Variation	Relevant paragraphs
SG 2	<p>Dangerous Goods Unit Airworthiness/Flight Operations Division Civil Aviation Authority of Singapore Singapore Changi Airport P.O. Box 1 Singapore 918141 Telephone: +65 6541 3487 Facsimile: +65 6545 6519 Email: caas_dangerousgoods@caas.gov.sg</p> <p>Singapore Air Navigation Order (ANO) defines munitions of war (MOW) as “weapons and ammunition designed for use in warfare or against any person, including any part designed for such weapons and ammunition”. MOW includes weapons (for sporting and non-sporting purposes) such as rifles, pistols and guns, and weapon components and parts. MOWs may themselves contain or be loaded with explosives, cartridges, charges, primers and ammunitions which are classified as dangerous goods in accordance with these Instructions.</p> <p>Operators wishing to carry munitions of war by air into, transiting, or out of Singapore must obtain an MOW permit and a dangerous goods permit in accordance with paragraphs 50C and 50D of the Air Navigation Order.</p> <p>Information and application forms for MOW permits may be obtained from the CAAS website (www.caas.gov.sg). All applications are to be made on prescribed forms and addressed to:</p> <p>Dangerous Goods Unit Airworthiness/Flight Operations Division Civil Aviation Authority of Singapore Singapore Changi Airport P.O. Box 1 Singapore 918141 Telephone: +65 6541 3487 Facsimile: +65 6545 6519 Email: caas_dangerousgoods@caas.gov.sg</p> <p>TR — TURKEY</p> <p>The Authority responsible for dangerous goods in Turkey is the Directorate General of Civil Aviation, one of the departments of the Ministry of Transportation:</p> <p>Directorate General of Civil Aviation Bosna Hersek Cad. 90. Sok. No. 5 Emek — Ankara Telephone: (0312) 215 50 82 215 61 72 215 73 73</p> <p>Facsimile: (0312) 212 46 84 215 80 94</p> <p>Comm: CIVIL AIR Telex: 44659 CAD TR AFTN: LTAYAAT SITA: ANKYXYA</p>	7;1
TR 2	<p>In the following cases, applications for diplomatic transit and landing flights authorization shall be made 10 work days before the planned flight:</p> <ul style="list-style-type: none"> — aircraft carrying explosives, weapons and ammunitions; — aircraft carrying army personnel and staff; — aircraft carrying radioactive material to/from Turkey. 	

Identifying code	Variation	Relevant paragraphs
UA — UKRAINE		
UA 1	<p>The exportation, importation and transit of all radioactive material, without exceptions, are subject to the approval of the State Export Control Service of Ukraine and a decision from the Environmental Safety Ministry (State Nuclear Regulatory Administration of Ukraine). Any questions regarding this variation should be addressed to:</p> <p style="padding-left: 40px;">State Export Committee of Ukraine 19/21 Frunze Street Kiev, 254080 UKRAINE Telephone/facsimile: 044-4624970</p> <p>or</p> <p style="padding-left: 40px;">State Nuclear Regulatory Administration of Ukraine 9/11 Arsenaina Street Kiev, 01011 UKRAINE Telephone: 044-2944224 Facsimile: (044) 2948895</p>	5;1.2 7;1
US — UNITED STATES		
US 1	<p>Transport of dangerous goods by air must be in accordance with United States' Regulations (49 CFR 171-180) or these Technical Instructions as limited by 49 CFR Part 171, Subpart C. The requirements of 49 CFR 175 apply to the offering, acceptance, and transportation of dangerous goods in commerce by aircraft to, from, or within the United States, and to any aircraft of United States' registry anywhere in air commerce. Part 175 contains additional requirements applicable to any person who performs, attempts to perform, or is required to perform a function subject to 49 CFR and is also applicable to air passengers and crew.</p> <p>When the Technical Instructions are used for consignments of dangerous goods, failure to comply with the Technical Instructions and all relevant United States' variations is a violation of the United States' regulations.</p> <p>The appropriate national authority for the United States is:</p> <p style="padding-left: 40px;">Associate Administrator for Hazardous Materials Safety Pipeline and Hazardous Materials Safety Administration U.S. Department of Transportation Washington, D.C. 20590-0001</p>	1;1.5
	<p>English must be used for all required package markings and for the dangerous goods transport document. Abbreviations may not be used unless they are specifically authorized by these Instructions or by Subpart C and D of 49 CFR 172.</p> <p>A copy of the transport document, or an electronic image thereof, must be retained by the shipper for not less than two years after the dangerous goods are accepted by the initial operator. Each shipping paper copy must include the date of acceptance by the initial operator, except that the date on the air waybill or bill of lading may be used in place of the date of acceptance by the initial operator. For a hazardous waste, the transport document must be retained for three years after the waste material is accepted by the initial operator.</p> <p><i>Note.— The United States' Regulations, as well as interpretations regarding their use, are available via the internet at http://www.phmsa.dot.gov/hazmat/regs. Questions regarding the Regulations may be directed to the Office of Hazardous Materials Safety Information Center at (800) 467-4922, (202) 366-4488 or by e-mail at infocntr@dot.gov.</i></p>	5;2.5 5;4.1.6.3
US 2	<p>In addition to the dangerous goods included in the Dangerous Goods List (Table 3-1) with the word "Forbidden" shown in columns 2 and 3, any material forbidden for transport by the United States' Regulations is also forbidden for transport under any circumstances to, from or within the United States (see 49 CFR 173.21 and the Hazardous Materials Table in 49 CFR 172.101).</p> <p>Unless specifically authorized by the Hazardous Material Table in 49 CFR 172.101, the transport of a liquid with a vapour inhalation toxicity meeting the criteria of Division 6.1, Packing Group I or a gas meeting the criteria of Division 2.3 is forbidden for transport aboard passenger and cargo aircraft to, from or within the United States.</p>	1;2.1 3;2 4;11

Identifying code	Variation	Relevant paragraphs
	<p>Primary (non-rechargeable) lithium metal batteries and cells (UN 3090) are forbidden for transportation aboard passenger-carrying aircraft. Such batteries transported in accordance with Section IA or IB of Packing Instruction 968 must be labelled with the CARGO AIRCRAFT ONLY label. Such batteries transported in accordance with Section II of Packing Instruction 968 must be marked "PRIMARY LITHIUM BATTERIES — FORBIDDEN FOR TRANSPORT ABOARD PASSENGER AIRCRAFT" or "LITHIUM METAL BATTERIES — FORBIDDEN FOR TRANSPORT ABOARD PASSENGER AIRCRAFT".</p> <p>Primary (non-rechargeable) lithium metal batteries and cells contained in or packed with equipment (UN 3091) are forbidden for transportation aboard passenger-carrying aircraft unless:</p> <ol style="list-style-type: none"> 1) the equipment and the batteries and cells are transported in accordance with Packing Instruction 969 or 970, as appropriate; 2) the package contains no more than the number of lithium metal batteries or cells necessary to power the intended piece of equipment; 3) the lithium content of each cell, when fully charged, is not more than 5 grams; 4) the aggregate lithium content of the anode of each battery, when fully charged, is not more than 25 grams; and 5) the net weight of lithium batteries does not exceed 5 kg (11 lb). <p>Primary (non-rechargeable) lithium metal batteries and cells contained in or packed with equipment (UN 3091) and transported in accordance with Section I of Packaging Instruction 969 or 970 that do not conform to the above provisions are forbidden for transportation aboard passenger-carrying aircraft and must be labelled with the CARGO AIRCRAFT ONLY label.</p> <p>Primary (non-rechargeable) lithium metal batteries and cells contained in or packed with equipment (UN 3091) and transported in accordance with Section II of Packaging Instruction 969 or 970 that do not conform to the above provisions are forbidden for transportation aboard passenger-carrying aircraft and must be marked "PRIMARY LITHIUM BATTERIES — FORBIDDEN FOR TRANSPORT ABOARD PASSENGER AIRCRAFT" or "LITHIUM METAL BATTERIES — FORBIDDEN FOR TRANSPORT ABOARD PASSENGER AIRCRAFT".</p> <p><i>Note 1.— Dangerous goods that are forbidden on passenger aircraft by 49 CFR 172.101 (Column 9A) are also forbidden on passenger aircraft even when the ICAO Technical Instructions permit such carriage. Dangerous goods that are forbidden on cargo aircraft by 49 CFR 172.101 (Column 9B) are also forbidden on cargo aircraft even when the ICAO Technical Instructions permit such carriage.</i></p> <p><i>Note 2.— Dangerous goods not permitted for carriage by passengers or crew in checked or carry-on baggage by 49 CFR 175.10 are not permitted for such carriage even when authorized by Part 8 of these Instructions. For example, the carriage of avalanche rescue backpacks by passenger or crew (see Table 8-1, 17)) is not authorized.</i></p>	
US 3	<p>For substances where this variation is identified in column 6 of Table 3-1, the following provisions apply:</p> <ol style="list-style-type: none"> 1) if A1 appears in column 7, the substance may not be transported to, from or within the United States aboard a passenger aircraft without the prior approval of the appropriate authority of the U.S. (see US 1); 2) if A2 appears in column 7, the substance may not be transported to, from or within the United States aboard a passenger or cargo aircraft without the prior approval of the appropriate authority of the U.S. (see US 1); 3) prototype lithium batteries and cells transported in accordance with Special Provision A88, and organic peroxides and self-reactive substances that are not identified by a technical name in 49 CFR 173.225(b) may not be transported to, from, or within the United States aboard a passenger or cargo aircraft without the prior approval of the appropriate authority of the U.S. (see US 1). 	3;1 Table 3-1
US 4	<p>Substances subject to additional requirements for air transport to, from or within the United States are described below. The additional requirements in III also apply to U.S. carriers operating outside the U.S.</p>	

Identifying code	Variation	Relevant paragraphs
---------------------	-----------	------------------------

- i. *Hazardous substances.* When a substance, including its mixtures and solutions, listed in Appendix A to 49 CFR 172.101 is offered for transport in a package in which the net quantity of the substance equals or exceeds the reportable quantity (RQ) indicated for the substance in Appendix A, the substance, mixture or solution is considered a hazardous substance unless:

- it is a petroleum product that is a lubricant or fuel; or
- it is in a concentration less than that shown in the following table based on the RQ specified for the material:

RQ Kilograms	Concentration by weight	
	Per cent	PPM
45.4	0.2	2 000
4.54	0.02	200
0.45	0.002	20

For mixtures of radionuclides, see Note 7 to Appendix A to 49 CFR 172.101.

Hazardous substances, except for those that are hazardous wastes as defined in Section II below, must comply with the following requirements:

- a) For a hazardous substance that is a dangerous good according to these Technical Instructions other than under the proper shipping names “ENVIRONMENTALLY HAZARDOUS SUBSTANCE, LIQUID, N.O.S.” or “ENVIRONMENTALLY HAZARDOUS SUBSTANCE, SOLID, N.O.S.”:
- ≠
- 1) unless already included in the required shipping name, and except for radioactive material in Class 7, the name of the hazardous substance shall be shown in parentheses, in association with the dangerous goods description on the transport document and in association with the proper shipping name on package marking. If the material contains two or more hazardous substances, at least two hazardous substances, including the two with the lowest reportable quantities (RQs), must be identified; and
 - 2) the letters “RQ” shall be entered on the transport document either before or after the basic description and in association with the proper shipping name required to be marked on the package.
- b) For hazardous substances that do not meet any other definition of dangerous goods according to these Technical Instructions:
- ≠
- 1) the hazardous substance shall be shipped under the basic dangerous goods description “UN 3082, ENVIRONMENTALLY HAZARDOUS SUBSTANCE, LIQUID, N.O.S., Class 9, III” or “un 3077, ENVIRONMENTALLY HAZARDOUS SUBSTANCE, SOLID, N.O.S., Class 9, III”, as appropriate, and in accordance with the requirements of these Technical Instructions applying to the shipment of goods under this description;
 - 2) except for 4;1.1.6, the package must meet all applicable General Packing Requirements of Part 4, Chapter 1 of these Instructions that would apply to dangerous goods of Packing Group III;
 - 3) the letters “RQ” shall be entered on the transport document either before or after the basic description and in association with the proper shipping name required to be marked on the package; and
- ≠
- 4) the name of the hazardous substance shall be shown in parentheses, in association with the dangerous goods description on the transport document and in association with the proper shipping name on package marking. If the material contains two or more hazardous substances, at least two hazardous substances, including the two with the lowest reportable quantities (RQs), must be identified.

Note.— The list of Hazardous Substances and the applicable RQ as shown in Appendix A to 49 CFR 172.101 is available via the internet at:

<http://www.phmsa.dot.gov/hazmat/regs/international/icao>

Identifying code	Variation	Relevant paragraphs
≠	<p>II. <i>Hazardous waste.</i> A hazardous waste is any material that is subject to the hazardous waste manifest requirements of the United States Environmental Protection Agency (EPA) specified in 40 CFR Part 262. The following requirements apply to the transport of hazardous wastes:</p> <p>a) For a hazardous waste that is a dangerous good according to these Technical Instructions other than under the proper shipping names “ENVIRONMENTALLY HAZARDOUS SUBSTANCE, LIQUID, N.O.S.” or “ENVIRONMENTALLY HAZARDOUS SUBSTANCE, SOLID, N.O.S.”:</p> <ol style="list-style-type: none"> 1) the word “WASTE” must precede the proper shipping name in the transport document and package markings; and 2) the requirements of 49 CFR 172.205, with respect to the hazardous waste manifest apply. <p>b) For hazardous wastes that do not meet any other definition of dangerous goods according to these Technical Instructions:</p> <ol style="list-style-type: none"> 1) the hazardous wastes shall be shipped under the basic dangerous goods description “UN 3082, WASTE ENVIRONMENTALLY HAZARDOUS SUBSTANCE, LIQUID, N.O.S., Class 9, III” or “UN 3077, WASTE ENVIRONMENTALLY HAZARDOUS SUBSTANCE, SOLID, N.O.S., Class 9, III”, as appropriate, and in accordance with the requirements of these Technical Instructions applying to the shipment of goods under this description; 2) the package must meet all applicable General Packing Requirements of Part 4, Chapter 1 that would apply to dangerous goods of Packing Group III; 3) the requirements of 49 CFR 172.205 with respect to the hazardous waste manifest apply; and 4) for those hazardous wastes that meet the definition of a hazardous substance, the letters “RQ” and the name of the hazardous substance in parentheses shall be shown in association with the basic description on transport documents and package markings. association with the basic description on transport documents and package markings. If the material contains two or more hazardous substances, at least two hazardous substances, including the two with the lowest reportable quantities (RQs), must be identified. 	
≠	<p><i>Note 1.— Hazardous wastes can only be transported within the United States by carriers who have obtained a Waste Transporter Identification Number from the Environmental Protection Agency (EPA).</i></p> <p><i>Note 2.— The assignment of substances described in I and II above to UN 3077 and UN 3082 is in accordance with special provision A97 of these Technical Instructions.</i></p> <p><i>Note 3.— The list of Hazardous Substances and the applicable RQ as shown in Appendix A to 49 CFR 172.101 is available via the internet at:</i></p> <p>http://www.phmsa.dot.gov/hazmat/regs/international/icao</p>	
≠	<p>III. <i>Other materials.</i> Materials which are not subject to the requirements of these Technical Instructions but meet the definition of a hazard class in 49 CFR Parts 171-180 must be transported in accordance with those regulations.</p> <p>US 5 An explosives article or substance may not be transported to, from or within the United States without prior approval by the appropriate authority of the U.S. (see US 1), Attention: Approvals and Permits Division (PHH-30)). Consumer fireworks may be approved by the appropriate authority of the United States or certified by an approved fireworks certification agency. Such approval and certification remains valid for subsequent transport of the article or substance provided there is no change in its composition, design or packaging. Except as otherwise provided in 49 CFR 172.320, each package containing an explosives article or substance must be marked with the EX-number (or in the case of consumer fireworks an EX or FC number) assigned in the approval or certification for each substance, article or device contained in the package. The EX-number may also be provided in association with the description of dangerous goods on the transport document rather than marked on the package as provided in 49 CFR 172.320(d). Articles of the kind described in 49 CFR 173.56(h) and 49 CFR 173.166(c)(2) do not require prior approval or an EX-number.</p>	2;1.3

Identifying code	Variation	Relevant paragraphs
US 6	Cylinders transported to, from or within the United States must be manufactured, inspected and tested in accordance with the applicable specifications given in 49 CFR 178, except that foreign cylinders received in the United States for charging may be transported for purposes of export from the United States in accordance with 49 CFR 171.23(a)(4). Portable tanks other than UN portable tanks manufactured outside the United States that meet the applicable requirements of the UN Model Regulations must be designed and approved in accordance with the requirements of 49 CFR 178.270 through 178.272.	Table 3-1
	Except as provided in 49 CFR 173.306, aerosol containers larger than 120 millilitres capacity (four fluid ounces) must be non-refillable metal or plastic aerosols. Aerosols must consist of a gas compressed, liquefied or dissolved under pressure, with the sole purpose of expelling a nonpoisonous (other than a Division 6.1 Packing Group III material) liquid, paste or powder and fitted with a self-closing release device allowing contents to be ejected by the gas.	2;2 PI 203, PI Y203 PI 204, PI Y204 PI 212 (UN 1950)
US 7	Lighters or other similar devices containing flammable gas (e.g. lighters for fireplaces and torches) may not be transported to, from or within the United States, unless the design of the device has been examined and tested by a person authorized by the appropriate authority of the United States (see US 1). For design samples being submitted for examination and testing, see 49 CFR 173.308.	
	Approval numbers issued by the appropriate authority of the United States (see US 1) prior to 1 January 2007 are no longer valid and each lighter design currently in production must be re-examined and tested under the provisions of 49 CFR 173.308.	5;2 5;4
US 10	The following additional requirements or limitations apply to the transport of radioactive material to, from or within the United States:	
	a) Radioactive material, other than that contained in excepted packagings, may not be offered for transport aboard passenger aircraft unless the radioactive material is intended for use in, or incident to, research or medical diagnosis or treatment. The transport document for the radioactive material, other than that contained in excepted packagings aboard a passenger aircraft, must contain a certification stating that the shipment contains radioactive material intended for use in, or incident to, research or medical diagnosis or treatment. Regardless of its intended use, no person may carry a Type B(M) package aboard a passenger-carrying aircraft, a vented Type B(M) package aboard any aircraft, or a liquid pyrophoric Class 7 material aboard any aircraft.	5;1.2 7;1
	b) No person may offer for transport aboard a passenger aircraft a package or an overpack with a transport index greater than 3.0.	
	c) No person may offer or transport plutonium aboard an aircraft unless: <ol style="list-style-type: none"> <li data-bbox="409 1251 1284 1299">1) the plutonium is contained in a medical device designed for individual human application; <li data-bbox="409 1314 1284 1341">2) the specific activity of the material containing the plutonium is less than 1 Bq/g; <li data-bbox="409 1356 1284 1425">3) the plutonium is shipped in a single package containing no more than an A₂ quantity of plutonium in any isotope or form and is shipped in accordance with applicable provisions of these Instructions for Class 7 radioactive material; or <li data-bbox="409 1440 1284 1488">4) the plutonium is specifically authorized for air shipment by the appropriate authority of the U.S. 	
	d) For a package containing radioactive material with an activity greater than: <ol style="list-style-type: none"> <li data-bbox="409 1545 558 1572">1) $3000 \times A_1$; <li data-bbox="409 1587 586 1614">2) $3000 \times A_2$; or <li data-bbox="409 1629 857 1656">3) 1000 TBq (27000 Ci), whichever is least, the notation "highway route controlled quantity" must appear on the transport document.	

Identifying code	Variation	Relevant paragraphs
	<p>e) Packages containing:</p> <ol style="list-style-type: none"> 1) $3000 \times A_1$; 2) $3000 \times A_2$; or 3) 1000 TBq (27000 Ci); whichever is least, <p>must bear the Radioactive material, Class 7, Category III — Yellow label.</p>	5;1.2.3.1.4
	<p>f) All Type B(U), Type B(M), Type H(U), Type H(M) and fissile package designs must be certified by the U.S. Department of Transportation. Individual packages with a criticality safety index exceeding 50, and shipments of packages with a total criticality safety index greater than 50 on passenger aircraft and 100 on cargo aircraft, may not be transported to, from or within the United States aboard a passenger or cargo aircraft without the prior approval of the appropriate authority of the United States (see US 1). Requests for package design certification and approvals should be directed to the appropriate authority of the U.S., Attention: Radioactive Materials Branch (PHH-23).</p>	6;7.7 6;7.8
	<p>g) Except for low specific activity material and surface contaminated objects, activity limits for Type A and Type B packages shall be limited in accordance with 49 CFR 173.431.</p>	
US 11	A nonspillable wet electric storage battery may only be regarded as not subject to these Instructions if the battery and its outer packaging are plainly and durably marked "NONSPILLABLE" or "NONSPILLABLE BATTERY" and the battery meets the conditions for being regarded as not subject to these Instructions contained in Special Provision A67.	Table 3-2
≠ US 12	On shipments to, from, within or transiting through the U.S., emergency response information as described below must be provided for all dangerous goods other than magnetized material and dangerous goods for which no transport document is required by 49 CFR.	5;4.1.4 7;4.4
≠	<p><i>Telephone number.</i> The transport document required by these Instructions must include an emergency response telephone number (including the area code and, for telephone numbers for locations outside the U.S., the international access code or the "+" (plus) sign, country code and city code needed to complete the call from within the U.S.) for use in the event of an incident involving the dangerous good(s). The number must be monitored at all times while the dangerous good is in transportation, including storage incident to transportation, by a person who:</p> <ol style="list-style-type: none"> 1) is knowledgeable of the hazards and characteristics of the dangerous good(s) being transported; 2) has comprehensive emergency response and accident mitigation information for the dangerous good(s); or 3) has immediate access to a person who possesses such knowledge and information. <p>The telephone number must be entered on the Transport document and its purpose clearly identified (e.g. "EMERGENCY CONTACT: ****"), either:</p> <ol style="list-style-type: none"> 1) immediately following the description of the dangerous good listed on the document, or 2) if only one number applies to each dangerous good listed on the Transport document, the information may be entered in a single prominent location, provided that the number is identified as the emergency response telephone number. <p>The telephone number must be the number of the person offering the dangerous goods for transportation or the number of an agency or organization capable of, and accepting responsibility for, providing the detailed information concerning the dangerous good. A person offering a dangerous good for transportation who lists the telephone number of an agency or organization must ensure that agency or organization has received current information on the material before it is offered for transportation.</p>	
≠	An emergency response telephone number is not required for materials properly described under the shipping names "Battery-powered equipment", "Battery-powered vehicle", "Carbon dioxide, solid", "Castor beans, flakes, meal or pomace", "Consumer commodity", "Dry ice", "Engines, internal combustion", "Fish meal, stabilized", "Fish scrap, stabilized", "Krill meal, PG III", "Refrigerating machines", "Vehicle, flammable gas powered", "Vehicle, flammable liquid powered", "Wheelchair, electric", and materials transported under the provisions applicable to limited quantities.	

Identifying code	Variation	Relevant paragraphs
	<p><i>Emergency response information.</i> Emergency response information relative to the dangerous good being transported must be immediately available at all times the dangerous good is present. This information should be appropriate for use in emergency and accident response to an incident, including an incident occurring during ground operations. The information must include as a minimum:</p>	
	<ol style="list-style-type: none"> 1) the description of the dangerous good in accordance with 5.4. of these Instructions; 2) immediate hazards to health; 3) risks of fire or explosion; 4) immediate precautions to be taken in the event of an accident or incident; 5) immediate methods for handling fires; 6) initial methods for handling spills or leaks in the absence of a fire; and 7) preliminary first aid measures. 	
	<p>The information must be printed in English, available away from the package containing the dangerous goods and immediately accessible in the event of an incident. Methods of compliance include, but are not limited to:</p>	
	<ol style="list-style-type: none"> 1) including the information on the Transport document; 2) locating the information in a separate document such as a material safety data sheet which includes at least all of the information listed above; or 3) providing the information for use in conjunction with the Transport document (or aboard aircraft, in conjunction with the Information to Pilot-in-Command as required in 7.4.1 of these Instructions), in a separate document, such as the ICAO <i>Emergency Response Guidance for Aircraft Incidents involving Dangerous Goods</i> (Doc 9481). 	
US 13	<p>Operators must comply with all requirements of 49 CFR, Part 175 (see US 1). These requirements include, but are not limited to, the following:</p>	
	<p>a) A package prepared in accordance with these Technical Instructions for transport to, from or within the United States must not be accepted unless the shipper has complied with all applicable United States variations indicated in these Technical Instructions.</p>	7;1
	<p>b) A copy of the transport document, or an electronic image thereof, must be retained by the initial operator for not less than one year after the dangerous goods are accepted by the initial operator. Each shipping paper copy must include the date of acceptance by the initial operator. The date on the shipping paper may be the date a shipper notifies the air carrier that a shipment is ready for transportation, as indicated on the airway bill or bill of lading, as an alternative to the date the shipment is picked up or accepted by the carrier. For a hazardous waste, the transport document copy must be retained for three years after the waste material is accepted by the initial operator.</p>	7;1
	<p>c) The notification to pilot-in-command must list, and provide the required information for, those additional materials considered to be dangerous goods under United States regulations as indicated through United States variations.</p>	7;4.1.1
≠	<p>d) Except for limited or excepted quantity materials, substances of Class 9, articles of UN 0012, UN 0014 or UN 0055 meeting the requirements of 49 CFR 173.63 (b), aircraft batteries transported as items of replacement (49 CFR 175.8), and those articles and substances considered to be dangerous goods under these Technical Instructions but which are not subject to 49 CFR Parts 170-180, the following limitations apply:</p>	
	<ol style="list-style-type: none"> 1) No more than 25 kg net weight of dangerous goods, and in addition thereto, 75 kg net weight of non-flammable gas, that are permitted to be carried aboard a passenger aircraft may be loaded aboard an aircraft in an inaccessible manner. 	
	<ol style="list-style-type: none"> 2) For transport by cargo aircraft, the following additional substances are also excepted from the above requirement: <ol style="list-style-type: none"> i) Class 3 (flammable liquid), Packing Group III (unless the substance is also labelled CORROSIVE). 	
≠	<ol style="list-style-type: none"> ii) Division 6.1 (toxic), (unless the substance is also labeled for any hazard class or division except FLAMMABLE LIQUID). 	

Identifying code	Variation	Relevant paragraphs
	iii) Division 6.2 (infectious substances).	
	iv) Class 7 (radioactive) material that does not meet the definition of another hazard class.	
+	vi) Class 9 (miscellaneous), limited quantity or excepted quantity material.	
+	vii) Articles of UN 0012, UN 0014 or UN 0055 also meeting the requirements of 49 CFR 173.63(b),	

Note 1.— Accessible means, on passenger-carrying or cargo-only aircraft, that each package is loaded where a crew member or other authorized person can access, handle, and, when size and weight permit, separate such packages from other cargo during flight, including a freight container in an accessible cargo compartment when packages are loaded in an accessible manner. Additionally, a package is considered accessible when transported on a cargo-only aircraft if it is:

- *in a cargo compartment certified by FAA as a Class C aircraft cargo compartment as defined in 14 CFR 25.857(c); or*
- *in an FAA-certified freight container that has an approved fire or smoke detection system and fire suppression system equivalent to that required by the certification requirements for a Class C aircraft cargo compartment.*

Note 2.— Inaccessible means all other configurations, including packages loaded where a crew member or other authorized person cannot access, handle, and, when size and weight permit, separate such packages from other cargo during flight, including a freight container in an accessible cargo compartment when packages are loaded in an inaccessible manner.

The following table provides the limits imposed by this variation:

<i>Applicability</i>	<i>Forbidden</i>	<i>Quantity limitation: 25 kg net weight of dangerous goods plus 75 kg net weight of non- flammable gas per cargo compartment</i>	<i>No limit</i>
Passenger carrying aircraft	Cargo aircraft only labelled packages	Inaccessible	Accessible
Cargo-only aircraft — packages authorized aboard a passenger-carrying aircraft	Not applicable	Inaccessible	Accessible
Cargo-only aircraft — packages not authorized aboard a passenger-carrying aircraft and displaying a cargo-aircraft-only label	Inaccessible	Not applicable	Accessible

- e) Operators must comply with the incident reporting requirements of 49 CFR 171.15, 171.16 and discrepancy reporting under 175.31. 7;4.4

Note.— Copies of the incident reporting form and guidance for completing it may be downloaded at:

<http://www.phmsa.dot.gov/hazmat/incident-reports>.

US 15	Except as provided for cylinders of compressed oxygen, no person may load or transport to, from or within the United States a package containing a dangerous good requiring an OXIDIZER label in an inaccessible cargo compartment that is not equipped with a fire or smoke detection system and a fire suppression system.	Table 3-1 PI 200 7;2 7;4.1
-------	--	-------------------------------------

Identifying code	Variation	Relevant paragraphs
	<p>Cylinders of compressed oxygen must be transported in accordance with the following:</p> <ol style="list-style-type: none"> No more than a combined total of six cylinders of compressed oxygen per aircraft may be stowed in cargo compartments not equipped with a fire or smoke detection system and a fire suppression system; Except for oxygen cylinders allowed to be transported in the passenger compartment under the conditions given below, oxygen cylinders transported on passenger aircraft or in an inaccessible cargo location on a cargo aircraft must be stowed horizontally as close as practicable to the floor of the cargo compartment or unit load device; When transported in a Class B compartment or its equivalent (i.e. an accessible compartment equipped with a fire detection system), cylinders of compressed oxygen must be loaded in a manner that a crew member can see, handle and, when size and weight permit, separate the cylinders from other cargo during flight. No more than six cylinders of compressed oxygen and, in addition, one cylinder of medical-use compressed oxygen per passenger needing oxygen at destination — with a rated capacity of 1 000 L (34 cubic feet) or less of oxygen — may be carried in a Class B aircraft cargo compartment or its equivalent; and Each cylinder must conform to the requirements identified in US Variation 6 and be packaged as required by US Variation 18. 	
	<p>A cylinder containing medical-use compressed oxygen, owned or leased by an aircraft operator or offered for transportation by a passenger needing it for personal medical use at destination, may be carried in the cabin of a passenger aircraft in accordance with the following provisions:</p> <ol style="list-style-type: none"> No more than six cylinders belonging to the aircraft operator and, in addition, no more than one cylinder per passenger needing the oxygen at destination, may be transported in the cabin of the aircraft; The rated capacity of each cylinder may not exceed 1 000 L (34 cubic feet); Each cylinder must conform to the requirements identified in US Variation 6 and must be placed in an overpack or outer packaging that conforms to the performance criteria of Air Transport Association (ATA) Specification 300 for Category I or placed in a metal, plastic or wood outer packaging that conforms to a UN standard at the Packing Group I or II performance level; and Oxygen cylinders transported under these provisions must be included in the information provided to the pilot-in-command in accordance with 7;4.1 of these Instructions. 	8;1.1.2
#	<p>US 16 Air bag inflators, air bag modules and seat-belt pretensioners may not be transported to, from or within the United States without prior approval by the appropriate authority of the United States (see US 1), Attention: Approvals and Permits Division (PHH-30). Such approval remains valid for subsequent transport provided there is no change in its composition, design or packaging. For domestic transport, air bag inflators, modules and pretensioners that meet the criteria for a Division 1.4G explosive must be transported using the description "Articles, pyrotechnic for technical purposes", UN 0431. The dangerous goods transport document (shipping papers) must contain the EX number or product code for each approved inflator, module or pretensioner in association with the basic description required in 5;4.1.4. If product codes are used, they must be traceable to the specific EX number assigned to the inflator, module or pretensioner, as applicable, by the appropriate authority of the United States. The EX number or product code is not required to be marked on the outer package. Air bag inflators, air bag modules and seat-belt pretensioners classified as Class 9 (UN 3268) in accordance with 49 CFR 173.166(b)(1) are not required to have an EX number assigned or have an EX number indicated on the transport documentation.</p>	
	<p>US 17 Shippers and operators must comply with the security requirements as prescribed in 49 CFR Part 172, Subpart I, as applicable.</p>	1;5
	<p>US 18 Cylinders containing Oxygen, compressed, UN 1072; Compressed gas, oxidizing, n.o.s., UN 3156; Liquefied gas, oxidizing, n.o.s., UN 3157; Nitrogen trifluoride, UN 2451; or Nitrous oxide, UN 1070 must be packaged as required by 49 CFR 173.302(f) and 173.304(f) and be placed in a rigid outer packaging that meets specified flame penetration and thermal resistance requirements as prescribed in Appendices D and E of 49 CFR Part 178. This requirement does not apply to cylinders containing medical-use compressed oxygen transported in accordance with US Variation 15.</p>	

<i>Identifying code</i>	<i>Variation</i>	<i>Relevant paragraphs</i>
	An oxygen generator, chemical (as defined in 49 CFR 171.8) may only be transported on cargo aircraft as provided for in 49 CFR 173.168. An oxygen generator, chemical, UN 3356, is not permitted for transport on passenger aircraft unless approved by the appropriate authority of the United States (see US 1). An oxygen generator, chemical, UN 3356, that is transported with a means of initiation attached must be classed and approved by the appropriate authority of the United States (see US 1) in accordance with the procedures specified in 49 CFR 173.56. This includes oxygen generators installed in personal breathing equipment transported in accordance with Special Provision A144 of these Instructions.	
	VC — SRI LANKA	
VC 1	No aircraft operator shall transport dangerous goods by air to, from or over Sri Lanka without explicit approval in writing from the Director General of Civil Aviation, Sri Lanka.	1;1.2
VC 2	Permission is usually granted for a specified period of time, subject to strict compliance with the ICAO Technical Instructions and any other conditions which the Director General of Civil Aviation deems necessary.	1;1.2
VC 3	Application for permission must be made to the: Director General of Civil Aviation Civil Aviation Authority of Sri Lanka No. 4, Hunupitiya Road, Colombo 02 Sri Lanka Facsimile: 94 11 2304644 or 94 11 2304649 at least ten days before the date of the first flight on which dangerous goods are to be carried.	1;1.2
VC 4	Infectious substances, including diagnostic specimens and biological products, are not permitted in international mail either to or from Sri Lanka.	1;2.3
VC 5	The English language shall be used for marking packages and overpacks.	5;2.5
VC 6	A brief text in the English language indicating the nature of the risk involved shall appear on all hazard labels.	5;3
VC 7	On shipments to, from or transiting through Sri Lanka, a 24-hour emergency response telephone number of a person who has all the information on the contents in the package (including access, country and city codes) must be provided on the shipper's declaration form.	5;4
	VU — VANUATU	
VU 1	The marking of packages and overpacks and the Dangerous Goods Transport Document accompanying dangerous goods consignments must be in English or French. If the State of Origin requires another language each shall be given equal prominence.	5;2.5 5;4.1.6.3
VU 2	Infectious substances are prohibited from entry to Vanuatu without prior approval from the Vanuatu Government Department of Health. Requests for approval should be addressed to: Director of Health P.O. Box 102, Port-Vila Vanuatu	1;1.2
VU 3	If an in-flight emergency occurs within Vanuatu airspace the pilot-in-command must inform the appropriate air traffic services unit, for the information of aerodrome authorities, of any dangerous goods on board the aircraft. The information must include the primary hazard, subsidiary risks for which labels are required and the quantity and location aboard the aircraft of the dangerous goods. If the situation permits, the information should also include the proper shipping name, class or division and, in the case of Class 1, the compatibility group.	7;4.3
VU 4	An operator who is involved in a dangerous goods incident in Vanuatu Territory must provide the authorities with information required to minimize hazards created by any spillage, leakage of fluid or other damage to dangerous goods.	7;4
VU 5	All hazards labels, including those identifying a subsidiary risk, must include text indicating the nature of the risk. The text must appear prominently in English or French in the lower half of the label as described in 5;3.5.	5;3.5

Identifying code	Variation	Relevant paragraphs
ZA — SOUTH AFRICA		
ZA 1	<p>Applications for approval to transport dangerous goods under Special Provision A1 or A2 and exemption applications must be directed to:</p> <p>The Commissioner for Civil Aviation South Africa Civil Aviation Authority Private Bag X08 Waterkloof 0145 Republic of South Africa</p> <p>Individual shippers must obtain a permit for the carriage by air of the following commodities in respect of each consignment before it is tendered for carriage to/from or through the airspace:</p> <p>Explosives: Class 1</p> <p>Chief Inspector of Explosives Private Bag X624 Pretoria 0001 Republic of South Africa</p> <p>For military armaments and ammunition of war:</p> <p>The Commissioner for Civil Aviation South African Civil Aviation Authority Private Bag X08 Waterkloof 0145 Republic of South Africa</p> <p>(See Note below.)</p> <p><i>Note.— Where armaments and/or ammunition are regarded as munitions of war or if they are to be used for military purposes, the approval of the Commissioner for Civil Aviation is required in terms of Section 15A of the Aviation Act No. 74 of 1962.</i></p>	3;1 (Table 3-1) 3;3
ZA 2	<p>Transport of dangerous goods by air must be in accordance with the current edition of the ICAO <i>Technical Instructions for the Safe Transport of Dangerous Goods by Air</i>, (Doc 9284-AN/905). Failure to comply with the Technical Instructions and all relevant South African variations is a violation of the South African Civil Aviation Regulations, 1997 as amended.</p>	
ZA 3	<p>On shipments to, from or transiting through South Africa, the shipper's declaration required by the Technical Instructions, must include a 24-hour emergency response telephone number (including applicable area and international codes) for use in the event of an incident involving the dangerous goods.</p> <p>The number must be monitored at all times by a person who:</p> <ol style="list-style-type: none"> 1) is knowledgeable of the hazards and characteristics of the dangerous goods being transported; or 2) has immediate access to a person who possesses such knowledge and information. 	5;4.1
ZA 4	<p>Radioactive material and infectious substances (including diagnostic specimens and biological products), are not permitted in airmail either to, from or through South Africa.</p>	1;2.3

**STATE VARIATIONS FROM THE TECHNICAL INSTRUCTIONS
FOR THE SAFE TRANSPORT OF DANGEROUS GOODS BY AIR**

To: Chief, Cargo Safety Section (CSS)
International Civil Aviation Organization
999 University Street
Montreal, Quebec
CANADA H3C 5H7

Email: krooney@icao.int

_____ (State) wishes the following variation(s) to be published on the ICAO website at www.icao.int/safety/DangerousGoods for incorporation in the 2015-2016 Edition of the Technical Instructions:

Variation

Relevant paragraphs

_____ Signature

_____ Title

Chapter 2

VARIATIONS NOTIFIED BY AIRLINE OPERATORS

2.1 It is hoped that all airline operators will abide completely by the requirements of the Technical Instructions and thus assist the smooth and rapid carriage of dangerous goods by air. If some special concerns or problems make it necessary for individual airlines to impose some more restrictive requirements, they are invited to notify such variations to ICAO for inclusion in this section.

2.2 Those variations which were notified to ICAO by airline operators prior to 31 July 2014 appear in Table A-2. Such variations, unless the context makes it otherwise apparent, are assumed to apply to all air transport performed by the operators concerned. Operator variations must not be less restrictive than the requirements of the Instructions and should refer only to safety matters and not to special handling or processing requirements.

2.3 If an operator needs to make variations based on new requirements appearing in this edition of the Instructions, it should notify ICAO by using the form appearing at the end of this Chapter. If such variations are received by 15 April 2015, they will appear in an Addendum to be published in May 2015.

2.4 The table of operator variations is based on data provided by the operators concerned. This table is provided for information only and should not be interpreted as having any (ICAO) regulatory status. Further information should be obtained from the appropriate airline operator.

2.5 In Table A-2 the affected Chapter(s) or paragraph(s) is indicated for each operator variation. Note that no reference to operator variations is made under the Chapter headings nor in the list of dangerous goods (Table 3-1). Variations have been notified by the following airlines:

ABSA Cargo — M3	Asiana — OZ
Adria Airways — JP	Astral Aviation — 8V
Aer Lingus — EI	+ Atlasjet Airlines — KK
+ Aerogal — 2K	Austral Lineas Aereas — AU
Aerolineas Argentinas — AR	Austrian Airlines — OS
Aeromexico — AM	Avianca Airlines — AV
AeroPeru — PL	Bangkok Airways — PG
Air Algerie — AH	Biman Bangladesh Airlines — BG
Air Astana — KC	Blue Dart Aviation Ltd. — BZ
Air Austral — UU	British Airways — BA
Air Berlin — AB	Brussels Airlines — SN
+ Air Bridge Cargo Airline — RU	Cameroon Airlines — UY
+ Aircalin — SB	Cargolux — CV
Air Canada — AC	Cargolux Italia — C8
Air Canada Rouge — RV	Caribbean Airlines — BW
Air Caraibes — TX	Carpatair SA — V3
Air Caraibes Atlantique — 8X	Cathay Pacific Airways — CX
Air China — CA	China Eastern Airlines — MU
≠ Air Corsica — XK	China Airlines — CI
Air Europa — UX	China Southern — CZ
Air France — AF	Comair — MN
Air Georgian Limited — ZX	Condor Flugdienst GmbH/Condor Berlin — DE
Air Hong Kong — LD	COPA Airlines — Cargo — CM
Air India — AI	Corsair — SS
Airkenya Express Ltd — P2	Croatia Airlines — OU
Air Madagascar — MD	Czech Airlines — OK
Air Mauritius — MK	Delta Air Lines — DL
Air Namibia — SW	Deutsche Lufthansa AG (Lufthansa) — LH
Air New Zealand — NZ	DHL Aero Expreso S.A. — D5
Air Niugini — PX	DHL Air Limited — D0
Air Tahiti — VT	Egyptair — MS
Air Tahiti Nui — TN	El Al Israel Airlines — LY
+ Air Transat — TS	Emirates — EK
Air Vanuatu — NF	ERA Aviation — 7H
Air Wisconsin — ZW	ETIHAD Airways — EY
Alaska Airlines — AS	European Air Transport Leipzig GmbH — DHL — QY
Alitalia Airlines — AZ	EVA Airways — BR
All Nippon Airways — NH	Federal Express — FX
American Airlines — AA	≠ Fiji Airways — FJ

Finnair — AY
 Garuda Indonesia — GA
 Great Wall Airlines — IJ
 Gulf Air — GF
 Hawaiian Airlines — HA
 + Hong Kong Airlines — HX
 Hong Kong Dragon Airlines (Dragonair) — KA
 IBERIA, Líneas Aéreas de España — IB
 Iberworld Airlines — IP
 + Icelandair — FI
 Iran Air — IR
 Japan Airlines — JL
 JAT Airways — JU
 Jazz Aviation LP — QK
 Jet Airways — 9W
 Jetstar — JQ
 Jett8 Airlines Cargo — JX
 JSC Siberia Airlines — S7
 Kenya Airways — KQ
 >
 KLM, Royal Dutch Airlines/KLM Cityhopper B.V. — KL
 Korean Airlines — KE
 + LACSA — LR
 LAN Airlines — LA
 LAN Argentina — 4M
 LAN Cargo — UC
 LANCO — L7
 LAN Colombia — 4C
 LAN Ecuador — XL
 LAN Express — LU
 LAN Peru — LP
 Lauda Air Luftfahrt AG — NG
 Llc GloBus — GH
 Luxair — LG
 Malaysia Airlines — MH
 Martinair Holland — MP
 MASAIR—Aerotransportes Mas de carga
 SA. de CV. — M7
 Meridiana — IG
 Miami Air International — GL
 Middle East Airlines — ME
 Mongolian Airlines — OM
 Nippon Cargo Airlines — KZ
 + Oman Air — WY
 Philippine Airlines — PR
 Qantas Airways — QF
 Qatar Airways — QR
 + Royal Brunei Airlines — BI
 Royal Jordanian — RJ
 SAS — Scandinavian Airlines System — SK
 Saudi Arabian Airlines — SV
 + Scoot Airlines — TZ
 Singapore Airlines/Singapore Airlines Cargo — SQ
 Skippers Aviation — JW
 >
 + Sky Regional Airlines — RS
 Southern Air Transport — SJ
 + Southwest Airlines — WN
 SriLankan Airlines — UL
 + SunExpress — XQ
 + SunExpress Deutschland GmbH — XG
 Swiss International — LX
 + TACA International — TA
 + TACA Peru — T0
 TAM Airlines — JJ
 Tampa Cargo — QT
 TAROM — RO
 Thai Airways International — TG
 + Thomas Cook Airlines — HQ
 + Thomson Airways — BY
 Transavia Airlines C.V. — HV
 Transportes del Mercosul — TAM — PZ
 TUIfly — HF
 Tunis Air — TU
 Turkish Airlines — TK
 Tyrolean Airways — VO
 Ukraine International Airlines — PS
 United Airlines — UA
 United Parcel Service — 5X
 + US Africa Airways — E8
 US Airways — US
 Vietnam Airlines — VN
 Virgin Atlantic — VS
 Virgin Australia — VA
 Yemen Airways — IY

Table A-2. Operator variations

The identifying code for each operator variation consists of a two- or three-character identifier for that operator plus a sequential number. Variations are listed in the alphabetical order of these identifying codes. For each variation, the relevant Part and Chapter or paragraph numbers of the Instructions are given.

Note.— Unless otherwise indicated, references cited within the text of the operator variations refer to the IATA Dangerous Goods Regulations.

<i>Identifying code</i>	<i>Variation</i>	<i>Relevant paragraphs</i>
AA — AMERICAN AIRLINES		
AA-01	Substances with a primary or subsidiary risk of Division 6.1 will not be accepted for carriage.	2;6
AA-02	Hazardous waste in any form, as defined by any regulation, will not be accepted for carriage.	
AA-03	Mercurial barometers will not be accepted for carriage as carry-on or checked baggage.	8;1
AA-04	Salvage packagings will not be accepted for carriage.	4;1.4
AA-05	Division 2.2 non-flammable gases with a subsidiary risk of 5.1 will not be accepted for carriage. (Exception: COMAT parts and supplies only when offered in DOT31FP compliant containers).	2;5 2;6
AA-06	Division 6.2, Category A infectious substance affecting animals (UN 2900) and humans (UN 2814) will not be accepted for carriage (see Packing Instruction 620).	2;6 4;8
AB — AIR BERLIN		
AB-01	Class 7, Radioactive material, fissile material and excepted packages will not be accepted on AB flights (see 10.5.8, 10.5.13 of the IATA Dangerous Goods Regulations).	1;6.1.5 2;7
AB-02	Packages allowed on cargo aircraft only or prepared according to packing instructions for cargo aircraft only (CAO) are not allowed on AB flights.	
AB-03	Dangerous goods in limited quantities ("Y" packing instructions) will not be accepted for carriage. (Exception: ID 8000 — Consumer commodity will be accepted.) (See 3;4 of these Instructions, 2.7 of the IATA Dangerous Goods Regulations and all "Y" packing instructions.)	3;4
AB-04	Camping stoves and fuel containers that have contained a flammable liquid fuel will not be accepted for carriage in baggage. This variation applies also to used camping stoves which have been thoroughly cleaned (see 2.3.2.5 of the IATA Dangerous Goods Regulations).	
AC — AIR CANADA		
AC-01	When a shipper's declaration is required for interline shipments, three (3) original copies must be provided with each shipment at the origin location.	5;4
AC-02	The shipper must provide a 24-hour emergency telephone number of a person/agency who is knowledgeable of the hazards, characteristics and actions to be taken in the case of an accident or incident concerning each of the dangerous goods being transported. This telephone number, including the country and area code, preceded by the words "Emergency Contact" or "24-hour number" must be inserted on the shipper's declaration for dangerous goods, preferably in the "Handling Information" box, e.g. "Emergency Contact +1 514-123-4567".	5;4
	A 24-hour emergency telephone number is not required for shipments that do not require a shipper's declaration for dangerous goods.	
AC-03	Salvage packaging will not be accepted for carriage.	4;1 5;1 5;2 6;2 6;4

<i>Identifying code</i>	<i>Variation</i>	<i>Relevant paragraphs</i>	
AC-04	Aircraft engines shipped under Special Provision A70 must be tendered with an original copy of the purged certificate and signed by the company that performed the maintenance or overhaul.	3;3 4;11	
AC-05	Internal combustion engines, being shipped either separately or incorporated into a machine or other apparatus, the fuel tank or fuel system of which contains or has contained fuel, must be classified as Engines, internal combustion, flammable liquid powered, UN 3166, Class 9 (including but not limited to chainsaws, lawnmowers, generators, outboard motors, etc.).	2;9 4;11	
AC-06	The number of packages of lithium batteries shipped in accordance with Section II of Packing Instructions 965 to 970 must be indicated on the air waybill.	4;11 5;4	
>			
	AF — AIR FRANCE		
≠	AF-01	Not used.	
	AF-02	Patient specimens will only be accepted if assigned to UN 2814 or UN 2900 or UN 3373, as appropriate. They are not permitted as baggage even if exempt from these Instructions. Biological substance, Category B — UN 3373 may only be accepted for carriage under specific requirements and after a prior Air France written approval has been granted (DZ.CA/OA.NA).	2;6 Table 3-1 5;4
	AF-03	Prior Air France approval is required for transport of dangerous goods under appropriate National Authorities' exemptions or approvals.	
	AH — AIR ALGERIE		
	AH-01	The shipper must provide a 24-hour emergency telephone number of a person/agency who is knowledgeable of the hazards, characteristics and actions to be taken in case of an accident or incident concerning (each of) the dangerous goods being transported. This telephone number, including country and area code, preceded by the words "Emergency contact" or "24-hour number" must be inserted on the shipper's declaration for dangerous goods (DGD) preferably in the "Additional handling information" box, e.g. "Emergency contact +47 67 50 00 00". A 24-hour emergency telephone number is not required for shipments that do not require a DGD.	5;4
	AH-02	Class 1 — Explosives. Due to the requirements of the Algerian Civil Aviation Authority, shippers must obtain prior approval from Air Algeria for all explosives, including ammunition in passenger baggage, transported to, from or through Algeria. The request must be submitted at least five (5) days prior to shipment or travel.	2;1 8;1
	AI — AIR INDIA		
	AI-01	Explosives must not be carried with the exception of items covered under UN 0012 and UN 0014, subject to approval from the Director General Civil Aviation.	2;1
	AI-02	Class 3 — Flammable liquids in Packing Group I are not accepted for carriage.	2;3
	AI-03	Division 4.3 — Substances which, in contact with water, emit flammable gases are not accepted for carriage.	2;4
	AI-04	Dangerous goods must not be consolidated with non-dangerous goods.	5;1.1

<i>Identifying code</i>	<i>Variation</i>	<i>Relevant paragraphs</i>
≠ AI-05	The carriage of UN 1845 — Carbon dioxide, solid (dry ice) will be limited to the following: <ul style="list-style-type: none"> — A330-200: not more than 1 500 kg. — B747-400/B777-300ER/B777-200LR: not more than 1 200 kg. — B787-800/A310: not more than 500 kg. — A319/A320/A321/B737-800: not more than 200 kg. 	Table 3-1 4;11
AI-06	A 24-hour emergency telephone number must be provided in the “Handling Information” box of the shipper’s declaration and air waybill.	5;4
AI-07	Fissile material will not be accepted for carriage.	2;7
AM — AEROMEXICO		
AM-01	Class 1 — Explosives will not be accepted for carriage, except for Class 1.4S (and Cartridges, power device (UN 0323) as COMAT). (See subsection 5.1 of the IATA Dangerous Goods Regulations.)	2;1
AM-02	Division 2.1 — Flammable gases and Division 2.2 — Non-flammable, non-toxic gases will be accepted for carriage subject to prior authorization. Division 2.3 — Toxic gases will not be accepted for carriage. (Exception: COMAT parts and supplies.)	2;2
AM-03	Class 3 — Flammable liquids in Packing Group I will not be accepted for carriage. Class 3 — Flammable liquids in Packing Group II or III will be accepted for carriage subject to prior authorization. (Exception: COMAT parts and supplies.)	2;3 Table 3-1
AM-04	Divisions 4.1, 4.2 and 4.3 substances in Packing Group I will not be accepted for carriage. Divisions 4.1, 4.2 and 4.3 substances in Packing Group II or III which have no subsidiary risk will be accepted for carriage subject to prior authorization (exception: COMAT parts and supplies).	2;4
AM-05	Division 5.1 — Oxidizing substances in Packing Group I will not be accepted for carriage. Division 5.1 — Oxidizing substances in Packing Group II or III will be accepted for carriage subject to prior authorization. Division 5.2 — Organic peroxides will not be accepted for carriage. (Exception: COMAT parts and supplies.)	2;5
≠ AM-06	Division 6.1 — Toxic substances in Packing Group I will not be accepted for carriage. Division 6.1 — Toxic substances in Packing Group II or III will be accepted for carriage subject to prior authorization. Division 6.2 — Infectious substances of Category A are forbidden for transport except when it is a matter of urgency, subject to prior authorization from the Secretary of Health of the Mexican Government. Infectious substances of Category B are permitted subject to prior notification and authorization from Aeromexico.	2;6
AM-07	Class 7 — Radioactive materials of Categories I, II and III will be accepted for carriage, provided the following conditions are complied with: <ul style="list-style-type: none"> — the radioactive materials (exception: COMAT parts and supplies) must be for medical diagnosis or medical research or medical treatment; or — to be used in analysis for medical purposes with direct relation to human health; and 	2;7 5;4

<i>Identifying code</i>	<i>Variation</i>	<i>Relevant paragraphs</i>
	<p>— the total transport index (TI) in one package or in a group of packages or on the aircraft must not exceed 3.0.</p> <p>The shipper's declaration accompanying each shipment of radioactive material of Category I, II or III must show the following endorsement: "This radioactive material is intended for use in, or incidental to, research or medical diagnosis or treatment".</p>	
AM-08	<p>Class 8 — Corrosives in Packing Group I will not be accepted for carriage.</p> <p>Class 8 — Corrosives in Packing Group II or III will be accepted for carriage subject to prior authorization.</p> <p>(Exception: COMAT parts and supplies.)</p>	2;8
AM-09	<p>Class 9 — Commodities pertaining to this class will not be accepted for carriage, with the exception of the following products (exception: COMAT parts and supplies):</p> <p>UN 1845 — Carbon dioxide, solid (dry ice) UN 2071 — Ammonium nitrate fertilizers UN 2807 — Magnetized material UN 3072 — Life-saving appliances, not self-inflating UN 3077 — Environmentally hazardous substance, solid, n.o.s.* UN 3082 — Environmentally hazardous substance, liquid, n.o.s.* UN 3166 — Engines, internal combustion, flammable liquid powered UN 3166 — Vehicle, flammable liquid powered UN 3245 — Genetically modified micro-organisms UN 3245 — Genetically modified organisms UN 3268 — Air bag modules UN 3268 — Seat-belt pretensioners UN 3316 — Chemical kit UN 3316 — First aid kit UN 3334 — Aviation regulated liquid, n.o.s. UN 3335 — Aviation regulated solid, n.o.s. UN 3363 — Dangerous goods in apparatus UN 3363 — Dangerous goods in machinery ID 8000 — Consumer commodity.</p>	2;9 Table 3-1
AM-10	Infected animals, dead or alive, will not be accepted for carriage.	2;6
AM-11	Dangerous goods in excepted quantities will not be accepted for carriage (see 2.6 of the IATA Dangerous Goods Regulation).	3;5
AM-12	Genetically modified micro-organisms and organisms must not cause a risk to humans, animals or plants.	2;6
AM-13	<p>Requests for authorization to transport dangerous goods which are not listed and those which require prior authorization must be made in advance via email to the following addresses:</p> <p>Carlos Hernandez Cortés: chernandez@aeromexicocargo.com.mx F. Javier Hernández M.: fjhernandezm@aeromexico.com.mx</p>	
AM-14	The shipper must provide a 24-hour emergency telephone number of a person/agency who is knowledgeable of the hazards, characteristics and actions to be taken in the case of an accident or incident concerning each of the dangerous goods being transported. This telephone number, including the country and area code, preceded by the words "Emergency contact", must be inserted on the shipper's declaration for dangerous goods (DGD) in the "Additional handling information" box, e.g. "Emergency contact +52 55 50 23 55 00".	5;4
AM-15	In case of shipments transported under State exemptions or approvals (e.g. required by Special Provision A1, A2, A88, A99 or A106), Strategic Partner of Aero Mexico Cargo must be contacted and copies of the DGD and approval or exemption, as applicable, must be provided by electronic mail. Shipments will not be accepted unless approval is granted by the Logistics Management Strategic Partner of Aeromexico Cargo (chernandez@aeromexicocargo.com.mx).	

Identifying code	Variation	Relevant paragraphs
AR — AEROLINEAS ARGENTINAS		
AR-01	Dangerous goods in excepted quantities will not be accepted.	3;5
AR-02	All blood products for transfusion and biological specimens from human or animal origin must be transported as cargo. They are not permitted as baggage.	2;6
AR-03	Dangerous goods as defined in the IATA Dangerous Goods Regulations will not be accepted in airmail.	1;2,3
AR-04	Wheelchairs or other battery-powered mobility devices with spillable batteries will be accepted only when the battery is removed from the wheelchair or mobility device. The spillable battery, classified as dangerous goods, can only be carried as cargo, in accordance with the requirements of these Instructions.	8;1
AR-05	Radioactive material will only be accepted for carriage on a passenger aircraft where the transport index of the package does not exceed 3.0.	2;7
AR-06	Small gaseous oxygen or air cylinders required for medical use will only be accepted empty as checked baggage. If the passenger requires supplementary oxygen, it will be provided by the operator.	8;1
AR-07	Gas cylinders in Division 2.2 (non-flammable, non-toxic) will not be permitted as baggage. Only empty cylinders will be permitted as checked baggage. Cylinders containing Division 2.1 and/or Division 2.3 will not be permitted as baggage.	8;1
AR-08	Interline transfer of dangerous goods will only be accepted if a copy of the acceptance checklist accompanies the consignment together with the dangerous goods declaration and the air waybill (see 9.1.1 of the IATA Dangerous Goods Regulations).	5;4 7;1
AR-09	The shipper must provide a 24-hour emergency telephone number of a person/agency who is knowledgeable of the hazards, characteristics and actions to be taken in the case of an accident or incident concerning each of the dangerous goods being transported. This telephone number, including the country and area code, preceded by the words "Emergency contact" or "24-hour number", must be inserted on the shipper's declaration for dangerous goods (DGD) in the "Additional handling information" box (see 8.1.6.11 and 10.8.3.11 of the IATA Dangerous Goods Regulations.)	5;4
≠	AR-10 Material safety data sheets (MSDS) must be provided for all dangerous goods classes, except for carbon dioxide, solid (dry ice), vehicles and engines (UN 3166) and non-dangerous goods having a chemical base. The MSDS may be written in Spanish or English. The MSDS must include the UN number, proper shipping name, packing group if necessary and all other relevant transport information. <i>Note.— The above requirements do not apply to company material (COMAT).</i>	5;4
+	AR-11 The only lithium ion batteries accepted for transport as cargo are those prepared in accordance with Section II of Packing Instructions 965 to 967. Lithium metal batteries of any kind will not be accepted for carriage as cargo. <i>Note.— The above prohibitions do not apply to company material (COMAT).</i>	4;11
+	AR-12 Other than wheelchairs powered by lithium ion batteries, any type of baggage with lithium batteries exceeding 100 Wh and batteries containing in excess of 2 g of lithium metal will not be accepted.	8;1
+	AR-13 For cargo shipments of lithium batteries, the shipper/agent must provide a lithium batteries declaration (which will be provided and made available by AR) or a material safety data sheet (MSDS) or business letter duly signed that includes the UN number, packing instruction number, packing instruction section applicable to the batteries being shipped and a phone number to contact someone able to provide more information concerning the batteries being transported. <i>Note.— The above requirements do not apply to company material (COMAT).</i>	4;11 5;4
+	AR-14 Any type of internal combustion or fuel cell engine either transported individually or incorporated into another machine or equipment, even when still in its new original packaging, will not be accepted as baggage. It may only be carried as cargo in accordance with the requirements of the IATA Dangerous Goods Regulations.	8;1

<i>Identifying code</i>	<i>Variation</i>	<i>Relevant paragraphs</i>
AS — ALASKA AIRLINES		
AS-01	Any device known as an oxygen generator (e.g. Oxygen generator, chemical; 5.1; UN 3356; PG II) will not be accepted for carriage, either via passenger or cargo aircraft.	2;5 Table 3-1
AS-02	Division 6.1 — No substance required to bear a “Toxic” label will be accepted for carriage.	2;6 Table 3-1 5;3
AS-03	Division 2.3 — No substance required to bear a “Toxic gas” label will be accepted for carriage.	2;3 Table 3-1 5;3
AS-04	For cargo aircraft only, Class 7 radioactive material will only be accepted in passenger aircraft quantities (total of 50 TI per aircraft and a maximum of 3 TI per package or overpack).	2;7 7;2.9
AS-05	Alaska Airlines requires that any vehicle shipped in accordance with Packing Instruction 950 must have the fuel tank drained of fuel as far as practicable. It is not acceptable to apply the provision that fuel up to one quarter of the tank capacity may remain.	4;11
AS-06	Class 9 — The following miscellaneous dangerous goods will not be accepted for carriage (see packing instruction [–] listed after the substance): UN 2211 — Polymeric beads, expandable, evolving flammable vapour [957].	2;9 Table 3-1
AS-07	Hazardous waste as defined by any regulation will not be accepted for carriage.	2;8
AS-08	Division 6.2 — Infectious substances, will only be accepted for carriage when: — being transmitted to a medical or diagnostic facility; or — are finished biological products bearing a U.S. government licence number of manufacture; and — are intended for human or veterinary use.	2;8
AS-09	Carriers operating as code-share partners using an AS flight number may not accept dangerous goods for shipment. Contact the operating carrier for specific information.	
≠ AS-10	Dangerous goods packages marked, labelled and in quantities acceptable on both passenger and cargo aircraft must not be included on the same shipper’s declaration for dangerous goods as “Cargo Aircraft Only” dangerous goods. Separate shipper’s declarations must be provided even though they may be part of the same consignment. <i>Note.— The above prohibitions do not apply to Alaska Airlines’ company material.</i>	5;4
≠ AS-11	The carriage of UN 1845 — Carbon dioxide, solid (dry ice) will be limited to the following: — Passenger-carrying aircraft: 82 kg (180 lb) per aircraft. — All cargo aircraft: 499 kg (1 100 lb) per aircraft. Advance arrangements with Alaska Air Cargo are essential.	7;2
AS-12	The following substances will not be accepted for carriage (see packing instructions [–] listed after each substance): UN 1162 — Dimethyldichlorosilane [377]	Table 3-1
AU — AUSTRAL LINEAS AEREAS		
AU-01	Dangerous goods in excepted quantities will not be accepted.	3;5
AU-02	All blood products for transfusion and biological specimens from human or animal origin must be transported as cargo. They are not permitted as baggage.	2;6
AU-03	Dangerous goods as defined in the IATA Dangerous Goods Regulations will not be accepted in airmail.	1;2.3

Identifying code	Variation	Relevant paragraphs
AU-04	Wheelchairs or other battery-powered mobility devices with spillable batteries will be accepted only when the battery is removed from the wheelchair or mobility device. The spillable battery, classified as dangerous goods, can only be carried as cargo, in accordance with the requirements of these Instructions.	8;1
AU-05	Radioactive material will only be accepted for carriage on a passenger aircraft where the transport index of the package does not exceed 3.0.	2;7
AU-06	Small gaseous oxygen or air cylinders required for medical use will only be accepted empty as checked baggage. If the passenger requires supplementary oxygen, it will be provided by the operator.	8;1
AU-07	Gas cylinders in Division 2.2 (non-flammable, non-toxic) will not be permitted as baggage. Only empty cylinders will be permitted as checked baggage. Cylinders containing Division 2.1 and/or Division 2.3 will not be permitted as baggage.	8;1
AU-08	Interline transfer of dangerous goods will only be accepted if a copy of the acceptance checklist accompanies the consignment together with the dangerous goods declaration and the air waybill (see 9.1.1 of the IATA Dangerous Goods Regulations).	5;4 7;1
AU-09	The shipper must provide a 24-hour emergency telephone number of a person/agency who is knowledgeable of the hazards, characteristics and actions to be taken in the case of an accident or incident concerning each of the dangerous goods being transported. This telephone number, including the country and area code, preceded by the words "Emergency contact" or "24-hour number", must be inserted on the shipper's declaration for dangerous goods (DGD) in the "Additional handling information" box (see 8.1.6.11 and 10.8.3.11 of the IATA Dangerous Goods Regulations.)	5;4
≠ AU-10	Material safety data sheets (MSDS) must be provided for all dangerous goods classes, except for carbon dioxide, solid (dry ice), vehicles and engines (UN 3166) and non-dangerous goods having a chemical base. The MSDS may be written in Spanish or English. The MSDS must include the UN number, proper shipping name, packing group if necessary and all other relevant transport information. <i>Note.— The above requirements do not apply to company material (COMAT).</i>	5;4
+ AU-11	The only lithium ion batteries accepted for transport as cargo are those prepared in accordance with Section II of Packing Instructions 965 to 967. Lithium metal batteries of any kind will not be accepted for carriage as cargo. <i>Note.— The above prohibitions do not apply to company material (COMAT).</i>	4;11
+ AU-12	Other than wheelchairs powered by lithium ion batteries, any type of baggage with lithium batteries exceeding 100 Wh and batteries containing in excess of 2 g of lithium metal will not be accepted.	8;1
+ AU-13	For cargo shipments of lithium batteries, the shipper/agent must provide a lithium batteries declaration (which will be provided and made available by AR) or a material safety data sheet (MSDS) or business letter duly signed that includes the UN number, packing instruction number, packing instruction section applicable to the batteries being shipped and a phone number to contact someone able to provide more information concerning the batteries being transported. <i>Note.— The above requirements do not apply to company material (COMAT).</i>	4;11 5;4
+ AU-14	Any type of internal combustion or fuel cell engine either transported individually or incorporated into another machine or equipment, even when still in its new original packaging, will not be accepted as baggage. It may only be carried as cargo in accordance with the requirements of the IATA Dangerous Goods Regulations.	8;1
≠	AV —AVIANCA AIRLINES	
AV-01	Wheelchairs with spillable or wet batteries will be accepted only when the battery has been removed from the wheelchair and packaged according to paragraphs 2.3.2.3 and 9.3.14 of the IATA Dangerous Goods Regulations.	8;1
AV-02	Oxygen, compressed, UN 1072 for medical use during flight, will not be accepted for carriage.	8;1

<i>Identifying code</i>	<i>Variation</i>	<i>Relevant paragraphs</i>
AV-03	Dangerous goods in airmail will not be accepted for carriage.	1;2,3
AV-04	Fissile radioactive material will not be accepted for carriage. (See 10.5.13 of the IATA Dangerous Goods Regulations.)	2;7
AV-05	Radioactive material will only be accepted for transport when the radioactive material is intended for medical diagnosis or treatment or medical and/or industrial research.	2;7 5;1
AV-06	Mercury — UN 2809 will be accepted for carriage provided the following conditions are complied with: <ul style="list-style-type: none"> — only combination packagings will be accepted; — outer packagings must have a strong inner lining or leak-proof bags, puncture-resistant material, impervious to mercury and must meet the performance standards of Packing Group I; and — must be overpacked with a plastic box. 	Table 3-1 4;1
AV-07	Arrangement with the airline is necessary for packages that contain dry ice.	Table 3-1 4;11 5;1 7;2
AV-08	Spanish must be used in addition to English for all markings and dangerous goods documentation for domestic and international transport from Colombia.	5;2 5;3 5;4
AY — FINNAIR		
AY-01	For information concerning operational limitations on Finnair flights and embargoes on Finnair destinations, the local Finnair cargo office or GSA agency should be contacted in advance. Contact information can be found at: www.finnaircargo.fi/en/cargo/contact-info.html .	
AY-02	Dangerous goods as defined in the IATA Dangerous Goods Regulations, including items exempted in subsection 2.4, will not be accepted in airmail. The only exception to this are patient specimens provided they meet the requirements of subsection 2.4.2(b).	1;2,3
≠ AY-03	In case of shipments transported under State exemptions or approvals (e.g. required by Special Provision A1, A2, A88, A99 or A106), Finnair Cargo Network & Hub Control (NHC) must be contacted and copies of the DGD and approval or exemption, as applicable, must be provided by fax or other means. Shipments will not be accepted unless approval is granted by NHC. Finnair Cargo Network & Hub Control (NHC) Telephone: +358-9-818 5450 Facsimile: +358-9-818 3927 Email: cargo.nhc@finnair.com	3;3 5;4
AY-04	Single packagings containing liquid dangerous goods are not acceptable for transport unless overpacked with, for example, a suitably sized wooden pallet to protect at least the top and bottom of the packagings.	4;1
AZ — ALITALIA AIRLINES		
AZ-01	Dangerous goods in consolidations will only be accepted for carriage where the consolidations contain only dangerous goods and must not include other non-regulated cargo.	7;1
AZ-02	Fissile radioactive material will only be accepted for carriage with the prior approval of the Alitalia qualified expert: Email: carboni.caterina@alitalia.it	1;6.1.5 2;7

<i>Identifying code</i>	<i>Variation</i>	<i>Relevant paragraphs</i>
≠	BA — BRITISH AIRWAYS	
BA-01	UN 3090 — Lithium metal batteries. Primary (non-rechargeable) lithium (metal) batteries and cells are prohibited from carriage as cargo on passenger aircraft. (See Packing Instruction 968.) This prohibition does not apply to: <ul style="list-style-type: none"> — UN 3091, UN 3480, UN 3481; — lithium batteries (rechargeable and non-rechargeable) covered by the provisions for dangerous goods carried by passengers or crew. (See Table 2.3.A of the IATA Dangerous Goods Regulations.) 	Table 3-1 4;11 8;1
BA-02	Infectious substances (UN 2814, UN 2900 and UN 3373) and biological products are not accepted for carriage in mail.	1;2,3 2;6 Table 3-1
BA-03	Hazardous waste in any form, as defined by any regulation, will not be accepted for carriage.	5;1,1
BA-04	Class 7 — Radioactive material of any kind will not be accepted for carriage.	2;7
>	BG — BIMAN BANGLADESH AIRLINES	
BG-01	Dangerous goods in excepted quantities will not be accepted.	3;5
+	BI — ROYAL BRUNEI AIRLINES	
BI-01	The shipper must provide a 24-hour emergency telephone number of a person/agency who is knowledgeable of the hazards, characteristics and actions to be taken in case of an accident or incident concerning each of the dangerous goods being transported. This telephone number, including the country and area code, preceded by the words "Emergency contact" or "24-hour number" should be shown on the shipper's declaration for dangerous goods (DGD) in the "Additional handling information" box and on the package, e.g. "Emergency contact +673 212 345 67" (see 8.1.6.11 and 10.8.3.11 of the IATA Dangerous Goods Regulations).	5;4
BI-02	Class 7 — Fissile radioactive material will not be accepted for carriage.	2;7
BI-03	The following are prohibited from carriage as cargo on BI passenger and cargo carrying flights: UN 3480 — Lithium ion batteries; and UN 3090 — Lithium metal batteries. This prohibition does not apply to: <ul style="list-style-type: none"> — UN 3481 — Lithium ion batteries contained in or packed with equipment; — UN 3091 — Lithium metal batteries contained in or packed with equipment; — Lithium batteries (rechargeable and non-rechargeable), covered under Table 8-1 (Table 2.3.A of the IATA Dangerous Goods Regulations), the provisions for dangerous goods carried by passenger or crew; and — BI company material (COMAT) permitted for transport on passenger and cargo aircraft conforming to the current edition of the IATA Dangerous Goods Regulations. UN 3481 — Lithium ion batteries contained in or packed with equipment, prepared for transport according to Section II of Packing Instruction 966 or 967 and UN 3091 — Lithium metal batteries contained in or packed with equipment, prepared for transport according to Section II of Packing Instruction 969 or 970, are required to appear on the information to the pilot-in-command (NOTOC).	Table 3-1 4;11

Identifying code	Variation	Relevant paragraphs
BR — EVA AIRWAYS		
+	Notes.— 1. Items from EVA's/UNI's COMAT materials and EGAT'S AOG materials which are listed in subsection 4.2 of the IATA Dangerous Goods Regulations will be exempted from the applicability of BR-01, BR-02, BR-03, BR-08 and BR-15. 2. EVA/UNI material and EGAT'S AOG material containing lithium metal batteries (RLM) (Packing Instructions 968 to 970) must be declared as cargo aircraft only (CAO) on the shipper's declaration for dangerous goods (DGD) and labeled with the cargo aircraft only handling label. 3. The restrictions list in all EVA variations do not apply to materials for R.O.C Military Logistic Command except BR-07, BR-15, BR-16, BR-17 and BR-19.	
BR-01	Dangerous goods requiring a cargo aircraft only (CAO) label will not be accepted except for: — Division 2.2 — Non-flammable, non-toxic gas without a subsidiary risk; — Class 3 — Flammable liquid, Packing Group II or III and without a subsidiary risk; and — Class 9 — Miscellaneous dangerous goods.	Table 3-1 5;3
BR-02	Dangerous goods in Packing Group I will not be accepted.	Table 3-1
BR-03	Other than explosives of Division 1.4S, Class 1 — Explosives will not be accepted for carriage.	2;1
BR-04	Dangerous goods in excepted quantities will not be accepted for carriage.	3;5
BR-05	Dangerous goods as defined in the IATA Dangerous Goods Regulations will not be accepted in airmail.	1;2.3
BR-06	Dangerous goods in consolidations will not be accepted for carriage, except for: — consolidations having one master air waybill with one house air waybill; or — consolidations having multi house air waybill containing ID 8000 (consumer commodity) and/or UN 1266 (Perfumery products) and/or UN 2807 (Magnetized material); or — consolidations having multi house air waybill containing ID 8000 (consumer commodity) and/or UN 1266 (Perfumery products) and/or UN 2807 (Magnetized material) including other general cargo; or — consolidations having multi house air waybill containing UN 1845 (Carbon dioxide, solid/dry ice) when used as a refrigerant for non-dangerous goods.	7;1
BR-07	Dangerous goods shipments transhipped to/from other operators will not be accepted for carriage, with the exception of UN 2807 (Magnetized material) and some class(es) or division(s) provided prior approval from Eva Air Headquarters has been obtained.	Table 3-1
≠	BR-08 UN 3356 — Oxygen generator, chemical, will not be accepted for carriage.	2;5 Table 3-1
BR-09	Division 2.1 — Flammable gas. The following flammable gases will not be accepted for carriage (see packing instructions [–] listed after the substance): UN 1057 — Lighters, disposable lighter with high tensile nylon or plastic body [201].	2;2 Table 3-1
BR-10	Division 2.3 — Toxic gases will not be accepted.	2;2
BR-11	Class 7 — Radioactive material, Category II-Yellow, III-Yellow, fissile material and excepted packages will not be accepted.	1;6.2
BR-12	Class 8 — Corrosives. The following corrosives will not be accepted for carriage (see packing instructions [–] listed after each substance): UN 1787 — Hydriodic acid [851, 855, Y840, 852, 856, Y841] UN 2803 — Gallium [867].	2;8 Table 3-1
BR-13	Class 9 — Miscellaneous dangerous goods. The following goods will not be accepted (see packing instructions [–] listed after the substance): UN 2211 — Polymeric beads, expandable, evolving flammable vapour [957].	2;9 Table 3-1

<i>Identifying code</i>	<i>Variation</i>	<i>Relevant paragraphs</i>
BR-14	Division 6.2 — Infectious substances in Category A must be loaded on a cargo aircraft.	2;6 7;2
≠ BR-15	Dangerous goods with final destinations EVA Air does not serve with their own aircraft (off-line station) can be accepted on board BR flights when advance arrangements have been made by reservation staff of the origin station in regard to the trucking to final destination.	
BR-16	Dangerous goods are not accepted to load on MD90 aircraft, except for: UN 1845 — Carbon dioxide, solid/dry ice which is used as a refrigerant for non-dangerous goods.	Table 3-1 7;2
≠ BR-17	If the shipper uses wooden skids for liquid substances contained in single packagings which are plastic drums/jerricans: — the shipper must ensure that there are no sharp objects protruding from the wooden skids and the plastic drums/jerricans must be protected by other strong outer packaging; or — if prepared as an open overpack, a suitably-sized and protective material such as plastic or foam must be used to protect at least the bottom of the plastic drums/jerricans from the wooden skid.	Part 4
+ BR-18	Lithium batteries which are fully regulated for transport and assigned to Class 9 (RLI/RLM) in accordance with Section I or Section IA of Packing Instructions 965 to 970 will not be accepted for carriage.	4;11
+ BR-19	Lithium metal batteries shipped in accordance with Section II of Packing Instructions 969 to 970 will not be accepted for transport aboard passenger aircraft.	4;11
BW — CARIBBEAN AIRLINES		
≠ BW-01	Caribbean Airlines will not accept for carriage on its aircraft substances with a primary or subsidiary risk of Division 6.1 in any form.	2;6 Table 3-1
BY — THOMSON AIRWAYS		
+ BY-01	Thomson Airways will not accept dangerous goods in Class 5 or 8 for transport on B-767 or B-787 aircraft with a net quantity in excess of 1 L or 5 kg per package. This restriction does not apply to battery-powered mobility aids described in 2.3.2.2 and 2.3.2.3 of the IATA Dangerous Goods Regulation. <i>Note.— This restriction does not apply to Thomson Airways B-737 and B-757 aircraft where carriage of Class 5 or 8 are permitted in accordance with the IATA Dangerous Goods Regulations.</i>	8;1
BZ — BLUE DART AVIATION LTD.		
BZ-01	Class 1 — Explosives, including fire extinguishers containing cartridges (cartridges power device of Division 1.4C or 1.4S), will not be accepted for carriage.	2;1 4;3 4;4
BZ-02	Dangerous goods in airmail will not be accepted for carriage.	1;2,3
BZ-03	Class 7 — Only the following radioactive material will be accepted for carriage: — radioactive material in “excepted packages”; and — radioactive material packaged in Type A packagings Class 7 — Radioactive material in Category I, II or III will be accepted for carriage, provided the radioactive material is intended for medical diagnosis or treatment or medical and/or industrial research.	
BZ-04	Radioactive material requiring a Fissile label, radioactive and fissile wastes will not be accepted for carriage.	2;7

<i>Identifying code</i>	<i>Variation</i>	<i>Relevant paragraphs</i>
BZ-05	The shipper must provide a 24-hour emergency telephone number of a person/agency who is knowledgeable of the hazards, characteristics and actions to be taken in the case of an accident or incident concerning each of the dangerous goods being transported. This telephone number, including the country and area code, preceded by the words "Emergency contact" or "24-hour number", must be inserted on the shipper's declaration for dangerous goods in the "Handling information" box. A 24-hour emergency telephone number is not required for shipments that do not require a shipper's declaration for dangerous goods.	5;4
BZ-06	Prior clarification must be taken from the operator for sending shipments containing magnets under UN 2807. Refer to instructions under Packing Instruction 953.	
≠ BZ-07	Dangerous goods listed in the list of high consequence dangerous goods will not be accepted for carriage. However, dangerous goods of Division 6.2, infectious substances of Category A (UN 2814 and UN 2900) and substances of Division 6.1 in Packing Group I will be accepted subject to prior approval by Blue Dart.	Table 1-7 2;6
BZ-08	Dangerous goods forbidden unless exempted will not be accepted for carriage.	
BZ-09	Dangerous goods offered for transport under State exemptions or approvals (e.g. required by Special Provisions A1, A2 and A106) will not be accepted for carriage.	3;3 1;1
CA — AIR CHINA		
CA-01	Dangerous goods in consolidations will not be accepted for carriage, except for: — consolidations containing UN 1845 — Carbon dioxide, solid (dry ice) when used as a refrigerant; and — consolidations with only one house air waybill.	7;1
CA-02	Not used.	
CA-03	Not used.	
CA-04	Sufficient absorbent material to absorb the contents of all inner packagings must be used for combination packagings containing corrosive liquid in Packing Groups I, II and III.	4;1
CA-05	The telephone or facsimile number of the consignee must be shown on the air waybill.	5;4
CA-06	Dangerous goods originating from China will not be accepted for carriage in airmail, except for radioactive material in excepted packages which meet the requirement of Part 1;2.3.1 of these Instructions.	1;2.3, 1;6
CA-07	Dangerous goods in excepted quantities originating from China will not be accepted, except for radioactive material in excepted packages.	1;6 3;5
CA-08	Cold storage for dangerous goods is not available, except for carbon dioxide, solid (dry ice) when used as a refrigerant for non dangerous goods.	
CA-09	Fireworks originating from China will not be accepted for carriage.	
CA-10	Single packagings, including composite packagings containing liquid dangerous goods, are not accepted for carriage unless overpacks are used. Such overpacks must be strong enough for carriage.	4;1
CA-11	The following dangerous goods are not accepted for carriage on Air China's international and domestic passenger flights: — Class 1 — Explosives with exception of 1.4S; — Division 2.3 — Toxic gas with exception of aerosols; — Division 6.1 — Toxic substance of Packing Group I; — Division 6.2 — Category A infectious substance, except when transported under the needs of the Ministry of Health of China, the Centers for Disease Control and Protection (CDC) of China and the Ministry of Forest of China; and — Class 7 — Radioactive material in Type B or in Type C packaging with Category III-yellow.	2;1 2;2 2;6 2;7

Identifying code	Variation	Relevant paragraphs
CA-12	Oxygen or air, gaseous cylinders required for medical use are not permitted in passengers' checked or carry-on baggage and on one's person. Should a passenger require supplementary oxygen, a prior request must be made to Air China Limited (see 2.3.4.1 of the IATA Dangerous Goods Regulations).	8;1
CI — CHINA AIRLINES		
≠ CI-01	The following dangerous goods, as listed in subsection 4.2 of the IATA Dangerous Goods Regulations, will not be accepted for carriage by China Airlines passenger flights: <ul style="list-style-type: none"> — Classes 1 to 8; — fully regulated lithium ion batteries (Class 9) as per Sections IA and IB of Packing Instruction 965 and Section I of Packing Instructions 966 to 967; — fully regulated lithium metal batteries (Class 9) as per Section I of Packing Instructions 969 to 970. <p><i>Note.— The above prohibitions do not apply to CI company material.</i></p>	Table 3-1 4;11
≠ CI-02	Dangerous goods in excepted quantities will not be accepted. This requirement does not apply to radioactive material in excepted packages.	3;5
≠ CI-03	Dangerous goods in consolidations will not be accepted for carriage except for: <ul style="list-style-type: none"> — consolidations having one master air waybill with one or more house air waybill containing only dangerous goods; — consolidations containing the following dangerous goods and general cargo: <ul style="list-style-type: none"> — UN 1845 — Carbon dioxide, solid/dry ice when used as a refrigerant for non-dangerous goods; — UN 2807 — Magnetized material in accordance with Packing Instruction 953 and with a field strength of no more than 0.418 A/m or 0.00525 Gauss measured at a distance of 4.6 m; — ID 8000 — Consumer commodities/UN 1266 — Perfumery products; — UN 3091 — Lithium metal batteries contained in or packed with equipment, UN 3480 — Lithium ion batteries, UN 3481 — Lithium ion batteries contained in or packed with equipment packed in accordance with Packing Instructions 965, 966, 967, 969 or 970. <p>(See 1.3.3, 8.1.2.4, 9.1.8 and 10.8.1.5 of the IATA Dangerous Goods Regulations.)</p>	7;1
≠ CI-04	Any liquid dangerous goods having primary hazard or subsidiary hazard of Class 8 — Corrosives must be packed either in combination packaging or single packaging with the top and bottom protected by wooden pallet and plank.	2;8 Table 3-1 4;1
CI-05	UN 3356 — Oxygen generator chemical will not be accepted for carriage, except China Airline's company material.	Table 3-1
≠ CI-06	The shipper must obtain an approval from the Atomic Energy Council of Taiwan for the import, export, transferring or transiting of radioactive material to, from or via Taiwan seven days prior to flight departure from the State of Origin. This requirement does not apply to radioactive material in excepted packages. <p style="margin-left: 20px;">Atomic Energy Council 80, Section 1, Chenggong Road Yonghe District New Taipei City 23452 Taipei Telephone: +886-2-8231 7919, Ext. 2179/2187 Facsimile: +886-2-8231 7829</p>	1;1 2.7 Table 3-1
CI-07	Dangerous goods offered for transport under State exemptions or approvals (e.g. as required by Special Provisions A1, A2 and A106) will not be accepted for carriage.	1;1 3;3

<i>Identifying code</i>	<i>Variation</i>	<i>Relevant paragraphs</i>
+	CI-08 Class 7 — Radioactive material must be segregated from packages of dangerous goods of Classes 1, 2, 3 and 8. This requirement does not apply to excepted packages of radioactive material.	2;7
CM — COPA AIRLINES — CARGO		
	CM-01 Explosives will not be accepted for carriage (excepted: Explosives of Division 1.4S packed on passenger aircraft).	2;1 Table 3-1
	CM-02 Division 2.1 — Flammable gas will not be accepted for carriage.	2;2 Table 3-1
	CM-03 Oxidizers and organic peroxides will not be accepted for a primary or subsidiary risk (excepted: UN 1072 — Oxygen compressed, with a subsidiary hazard).	2;5 Table 3-1
	CM-04 Radioactive material will not be accepted for carriage.	2;7 Table 3-1
CV — CARGOLUX		
	CV-01 Fissile material, as defined in these Instructions, will not be accepted for carriage.	2;7 Table 3-1
	CV-02 Wastes, any kind, will not be accepted for carriage.	Table 3-1
≠	CV-03 Not used.	
+	CV-04 Lithium metal cells and batteries (UN 3090), including those approved by an appropriate authority under Special Provision A88 or A99 and packed in accordance with Packing Instruction 968 are prohibited from carriage on Cargolux aircraft. This prohibition does not apply to: <ul style="list-style-type: none"> — Lithium metal cells and batteries packed with or contained in equipment (UN 3091) in accordance with Packing Instruction 969 or 970; — Lithium ion cells and batteries (UN 3480) in accordance with Packing Instruction 965; and — Lithium ion cells and batteries packed with or contained in equipment (UN 3481) in accordance with Packing Instruction 966 or 967. 	Table 3-1 3;3 4;11
CX — CATHAY PACIFIC AIRWAYS		
	CX-01 Not used.	
	CX-02 All combination packagings containing liquid dangerous goods in Packing Group I, II or III must contain sufficient absorbent material to absorb the entire contents of all the inner packagings.	4;1
	CX-03 Not used.	
	CX-04 The shipper must provide a 24-hour emergency telephone number of a person/agency who is knowledgeable of the hazards, characteristics and actions to be taken in case of an accident or incident concerning (each of) the dangerous goods being transported. This telephone number, including the country and area code, preceded by the words "Emergency contact" or "24-hour number", must be inserted on the shipper's declaration for dangerous goods (DGD), preferably in the "Additional handling information" box, e.g. "Emergency contact +47 67 50 00 00". (See 8.1.6.11 and 10.8.3.11 of the IATA Dangerous Goods Regulations.)	5;4
≠	CX-05 Liquid dangerous goods in single packagings of drums or jerricans of any material must be prepared as follows: <ol style="list-style-type: none"> 1) the steel drums/plastic drums/plastic jerricans must be protected by other strong outer packaging such as a fibreboard box; or 2) if prepared as an open overpack, a suitably-sized plastic, foam or wooden pallet must be used to protect at least the top and bottom of the packaging. 	2;8

<i>Identifying code</i>	<i>Variation</i>	<i>Relevant paragraphs</i>
CX-06	In addition to the requirements in 8.2.5 of the IATA Dangerous Goods Regulations, UN number(s) of all shipments of dangerous goods in excepted quantities must be indicated on the air waybill.	5;4
CX-07	Lithium metal cells and batteries (UN 3090) are prohibited from carriage as cargo on Cathay Pacific Airways aircraft. This prohibition applies to Section IA, IB and Section II of Packing Instruction 968. This prohibition does not apply to: <ul style="list-style-type: none"> — lithium metal cells and batteries packed with or contained in equipment (UN 3091) in accordance with Packing Instruction 969 or 970; — lithium ion cells and batteries (UN 3480 and UN 3481) in accordance with Packing Instruction 965, 966 or 967; or — lithium batteries (rechargeable and non-rechargeable) covered by the Provisions for Dangerous Goods Carried by Passengers or Crew. (See 2.3.2 to 2.3.5 and Table 2.3.A of the IATA Dangerous Goods Regulations and Part 8 of these Instructions.) 	Table 3-1 4;11 8;1
CX-08	All shipments of lithium batteries contained in equipment prepared in accordance with Section II of Packing Instruction 967 or 970 must include the mandatory wording on the air waybill as shown in Section II (“lithium ion batteries, in compliance with Section II of PI967” or “lithium metal batteries, in compliance with Section II of “PI970”). This applies even to shipments where no lithium battery handling label is required to be affixed to the package(s).	4;11
CZ — CHINA SOUTHERN		
CZ-01	Dangerous goods in excepted quantities originating from China will not be accepted.	3;5
CZ-02	Dangerous goods in consolidations will not be accepted, except for: <ul style="list-style-type: none"> — consolidations containing UN 1845, Carbon dioxide, solid (dry ice) when used as a refrigerant; — consolidations with only one house air waybill. 	Table 3-1 7;1
CZ-03	The shipper must provide a 24-hour emergency telephone number of a person/agency who is knowledgeable of the hazards, characteristics and actions to be taken in the case of an accident or incident concerning each of the dangerous goods being transported. This telephone number, including the country and area code, preceded by the words “Emergency contact” or “24-hour number”, must be inserted on the DGD, preferably in the “Additional handling information” box. A 24-hour emergency telephone number is not required for shipments that do not require a shipper’s declaration for dangerous goods.	5;4
CZ-04	Cold storage for dangerous goods is not available, except for carbon dioxide, solid (dry ice) when used as a refrigerant.	
≠ CZ-05	CSN will not appoint sales agents to accept or handle dangerous goods in China except for dangerous goods with special approval.	
CZ-06	Division 2.3 — Toxic gases will not be accepted.	2;2 Table 3-1
CZ-07	Only radioactive material Category I-White and Category II-Yellow will be accepted.	2;7 Table 3-1 5;1
≠ CZ-08	Lithium metal or lithium alloy cells and batteries (UN 3090) are prohibited from carriage as cargo on cargo aircraft. This prohibition does not apply to: <ul style="list-style-type: none"> — lithium metal or lithium alloy cells and batteries packed with or contained in equipment (UN 3091) transported in accordance with Section II of Packing Instruction 969 or 970. — lithium metal or lithium alloy cells and batteries packed with or contained in equipment (UN 3091) that fall into the category of company materials (COMAT); 	Table 3-1 4;11

<i>Identifying code</i>	<i>Variation</i>	<i>Relevant paragraphs</i>	
C8 — CARGOLUX ITALIA			
≠	C8-01	Radioactive material as defined in these Instructions will not be accepted for carriage.	2;7 Table 3-1
	C8-02	Wastes, any kind, will not be accepted for carriage.	Table 3-1
≠	C8-03	Not used.	
+	C8-04	Lithium metal cells and batteries (UN 3090), including those approved by an appropriate authority under Special Provision A88 or A99 and packed in accordance with Packing Instruction 968 are prohibited from carriage on Cargolux Italia aircraft. This prohibition does not apply to: <ul style="list-style-type: none"> — Lithium metal cells and batteries packed with or contained in equipment (UN 3091) in accordance with Packing Instruction 969 or 970; — Lithium ion cells and batteries (UN 3480) in accordance with Packing Instruction 965; and — Lithium ion cells and batteries packed with or contained in equipment (UN 3481) in accordance with Packing Instruction 966 or 967. 	Table 3-1 3;3 4;11
DE — CONDOR FLUGDIENST GMBH/CONDOR BERLIN			
	DE-01	Dangerous goods in limited quantities (“Y” packing instructions) will not be accepted for carriage (Exception: ID 8000 — Consumer commodity will be accepted).	3;4
	DE-02	Dangerous goods in consolidations will not be accepted for carriage, except for the following shipments: <ul style="list-style-type: none"> — consolidations containing UN 1845, Carbon dioxide, solid (dry ice) when used as a refrigerant; — consolidations with only one house air waybill; — consolidations with more than one house air waybill, in case of identical shipper. 	7;1
	DE-03	Biological substance, Category B (UN 3373) will not be accepted in airmail.	Table 3-1 1;2.3
	DE-04	Oxygen generators will not be accepted.	Table 3-1
	DE-05	Biological substance, Category B (UN 3373), will not be accepted.	Table 3-1
	DE-06	Fissile material will not be accepted for carriage.	Table 3-1
≠	DE-07	Class 7 — Radioactive material of Categories II-Yellow (“RRY” code) and III-Yellow will not be accepted for carriage. Radioactive material of Category I-White and radioactive material in excepted packages are subject to prior authorization from DE-HDQ.	2;7
	DE-08	Heat-producing articles such as underwater torches (diving lamps) and soldering irons are only allowed as carry-on baggage.	8;1
+	DE-09	The shipper must provide a 24-hour emergency telephone number of a person/agency who is knowledgeable of the hazards, characteristics and actions to be taken in case of an accident or incident concerning (each of) the dangerous goods being transported. This telephone number, including the country and area code, preceded by the words “Emergency contact” or “24-hour number”, must be inserted on the shipper’s declaration for dangerous goods (DGD), preferably in the “Additional handling information” box, e.g. “Emergency contact +47 67 50 00 00”. (See 8.1.6.11 and 10.8.3.11 of the IATA Dangerous Goods Regulations.)	5;4
DL — DELTA AIRLINES			
	DL-01	Class 7 — Only the following radioactive material will be accepted for carriage: <ul style="list-style-type: none"> — radioactive material in “excepted packages”; and 	1;6 2;7 5;1

<i>Identifying code</i>	<i>Variation</i>	<i>Relevant paragraphs</i>
	<p>— UN 2915 — Radioactive material, Type A package and UN 3332 — Radioactive material, Type A package, special form.</p> <p>Radioactive material is limited to 3.0 TI per aircraft.</p>	
DL-02	Hazardous waste or any dangerous goods meeting the definition of hazardous waste will not be accepted for carriage.	Table 3-1
DL-03	<p>All packed in one (APIO) packages containing both a “hydroxide” and an “acid” in the proper shipping name or technical name must be accompanied by the following, signed, statement of safety from the shipper:</p> <p>This shipment complies with 5.0.2.11. The acid and hydroxide, if mixed, will not react dangerously.</p> <p>This statement must appear in the “Additional handling information” area of the shipper’s declaration for dangerous goods and be signed by the same person who signs the completed shipper’s declaration.</p>	Table 3-1 5;4
DL-04	Dangerous goods packaged as an all packed in one (APIO) contained within an overpack will not be accepted.	
DL-05	Division 6.1, Toxic Substances in Packing Group I will not be accepted for carriage.	2;6
DL-06	UN 3480, Lithium ion batteries, Packing Instruction 965, Sections IA and IB will not be accepted for transport. UN 3480, Lithium ion batteries offered under Section II provisions will be accepted.	4;11
D0 — DHL AIR LIMITED		
D0-01	<p>Dangerous goods shipments transported by DHL Air Limited (DHL) will only be accepted by advance arrangements with, and approval by, the Regional Restricted Commodities Group — DHL Express Europe Headquarters before presenting for transport.</p> <p>Regional Restricted Commodities Group — DHL Express Europe Headquarters Telephone: +49 0 341 4499 4949 Facsimile: +49 0 4499 88 4982 Email: rcgalert@dhl.com</p>	
D0-02	The waybill for dangerous goods in “Excepted Quantities” must show the applicable UN number in addition to the requirements of 3;5.5 of these Instructions and 2.6.8.2 of the IATA Dangerous Goods Regulations.	3;5
D0-03	All lithium batteries, including refurbished, prepared under Section II of Packing Instructions 965 to 970 will only be accepted for carriage with the approval of the Regional/Global Restricted Commodities Group — DHL Express Europe Headquarters.	4;11
D0-04	It is forbidden to carry weapons, munitions of war or parts of them, except with the express exemption of the national authorities. In this case, they must be carried in the aircraft in a place which is inaccessible to passengers during flight and, in the case of firearms, uncharged. Such items can only be accepted by advance arrangements and approval by the Regional Restricted Commodities Group — DHL Express Europe Headquarters.	2;1 Table 3-1 7;2
D0-05	Not used.	
D0-06	Radioactive and fissile wastes will not be accepted for carriage.	2;7
D0-07	Not used.	

Identifying code	Variation	Relevant paragraphs
D0-08	<p>Handwritten shipper's declarations will not be accepted. The following fields on the shipper's declaration must be typed or computer generated:</p> <p>UN or ID number including the prefix, proper shipping name, hazard class or division, subsidiary risk or division(s), packing group, packaging type, packing instruction, authorization and emergency telephone number.</p> <p style="text-align: center;"><i>Note.— The technical name, when required, may be handwritten.</i></p> <p>For radioactive shipments, in addition to the items listed above, the following must also be typed or computer generated:</p> <p style="padding-left: 40px;">Radionuclide, special form or physical and chemical form. All other entries may be handwritten.</p> <p>Handwritten alterations/amendments to an entry required to be typed per D0-08 are acceptable if each alteration/amendment is legible and signed with the same signature used to sign the shipper's declaration.</p>	5;4
D0-09	<p>The shipper must provide a 24-hour emergency telephone number of a person/agency who is knowledgeable of the hazards, characteristics and actions to be taken in the case of an accident or incident concerning each of the dangerous goods being transported. This telephone number, including the country and area code, preceded by the words "Emergency contact" or "24-hour number", must be inserted on the DGD, preferably in the "Handling information" box.</p> <p>A 24-hour emergency telephone number is not required for shipments that do not require a shipper's declaration for dangerous goods.</p> <p>D5 — DHL AERO EXPRESO S.A.</p>	5;4
D5-01	Class 1 — Explosive articles will not be accepted for carriage or handling by DHL Aero Expreso S.A. or any other operator flying on our behalf. This variation does not apply to those parts or devices used for the DHL Aero Expreso aircraft during normal operations, where a written authorization must be obtained from the Network Operations Department.	2;1
D5-02	With the exception of excepted quantities of radioactive material (RRE), DHL Aero Expreso will not accept for carriage any other article or substance belonging to Class 7.	1;6 2;7 3;5
D5-03	Dangerous goods in airmail will not be accepted for carriage.	1;2,3
D5-04	Shipments under State approval in accordance with Special Provision A2 will not be accepted.	3;3
D5-05	<p>The shipper must provide a 24-hour emergency telephone number of a person/agency who is knowledgeable of the hazards, characteristics and actions to be taken in case of an accident or incident concerning (each of) the dangerous goods being transported. This telephone number, including country and area code, preceded by the words "Emergency contact" or "24-hour number" must be inserted on the shipper's declaration for dangerous goods (DGD) preferably in the "Additional handling information" box, e.g. "Emergency contact +47 67 50 00 00".</p> <p>A 24-hour emergency telephone number is not required for shipments that do not require a DGD.</p> <p>EI — AER LINGUS</p>	5;4
EI-01	Single packagings containing liquid dangerous goods packed in steel or aluminium drums (1A1, 1A2, 1B1, 1B2) will be accepted for transport only when overpacked.	4;1 6;1
EI-02	In addition to the requirement of 6.0.4.1 of the IATA Dangerous Goods Regulations, packages where UN specification marking is printed on a label which is attached to the package will not be accepted for transport.	5;2, 5;3
EI-03	Salvage packaging will not be accepted for transport.	4;1

<i>Identifying code</i>	<i>Variation</i>	<i>Relevant paragraphs</i>
EK — EMIRATES		
EK-01	An emergency response contact number provided by the shipper must be inserted in the "Additional handling information" box of the shipper's declaration for dangerous goods.	5;4
+ EK-02	Not used.	
EY — ETIHAD AIRWAYS		
EY-01	The shipper must provide a 24-hour emergency telephone number of a person/agency who is knowledgeable of the hazards, characteristics and actions to be taken in case of an accident or incident concerning (each of) the dangerous goods being transported. This telephone number, including country and area code, preceded by the words "Emergency contact" or "24-hour number" must be inserted on the shipper's declaration for dangerous goods (DGD) preferably in the "Additional handling information" box, e.g. "Emergency contact +47 67 50 00 00". A 24-hour emergency telephone number is not required for shipments that do not require a DGD.	5;4
≠ EY-02	All Class 1 — Explosives, Division 6.2 — Infectious substances and Class 7 — Radioactive materials and salvage packagings, as defined in the IATA Dangerous Goods Regulations, will not be accepted for carriage unless prior approval and booking arrangements are obtained from: ETIHAD Airways Cargo Reservations P.O. Box 35566 Cargo Village Abu Dhabi International Airport United Arab Emirates Telephone: +971 2 599 0099 Email: cargocs@etihad.ae	2;1 2;6 2;7
EY-03	Dangerous goods in single packagings and cryogenic containers (dewars) are not accepted for carriage unless overpacked.	4;1
≠ EY-04	Fully regulated lithium metal batteries (IMP code RLM (see B.2.2.4 of the IATA Dangerous Goods Regulations)) will not be accepted (see Packing Instructions 968 to 970).	4;11
EY-05	Dangerous goods in excepted quantities will not be accepted.	3;5
EY-06	Salvage packaging will not be accepted.	4;1
EY-07	Dangerous goods as defined in the IATA Dangerous Goods Regulations will not be accepted in airmail.	1;2,3
FJ — FIJI AIRWAYS		
≠ FJ-01	Radioactive material, including all categories of excepted packages, will not be accepted for transport (see 10.10.2 of the IATA Dangerous Goods Regulations).	1;6 2;7 3;5
+ FJ-02	The carriage of ammunition in checked baggage is not permitted on board FJ aircraft (see 2.3.2.1 of the IATA Dangerous Goods Regulations).	8;1

<i>Identifying code</i>	<i>Variation</i>	<i>Relevant paragraphs</i>						
+	FI — ICELANDAIR							
FI-01	<p>The maximum total transport index (TI) for Class 7 — Radioactive material permitted onboard Icelandair-operated aeroplane types is as follows:</p> <ul style="list-style-type: none"> — B757-200/300: Maximum total TI: 12.0 Maximum TI per compartment: 3.0 — B757-200PF/PCF (all-cargo aircraft): Maximum total TI: 50 <p>Separation minima must be observed in accordance with chapter 10.9.3.7 of the IATA Dangerous Goods Regulations and as prescribed in the Icelandair Ground Operations Manual according to aircraft type.</p>	7;2.10.6						
FI-02	<p>UN 1845 — Carbon dioxide, solid (dry ice) will be accepted for carriage on Icelandair flights provided the following maximum amounts are met and complied with:</p> <table style="width: 100%; border-collapse: collapse;"> <thead> <tr> <th style="text-align: left;">Aeroplane type</th> <th style="text-align: left;">Maximum quantity permitted</th> </tr> </thead> <tbody> <tr> <td>B757-200/300</td> <td>100 kg (220 lb)</td> </tr> <tr> <td>B757PF/PCF</td> <td>300 kg (660 lb)</td> </tr> </tbody> </table> <p>Approval to carry larger quantities may be requested via email at security@icelandair.is.</p>	Aeroplane type	Maximum quantity permitted	B757-200/300	100 kg (220 lb)	B757PF/PCF	300 kg (660 lb)	7;2
Aeroplane type	Maximum quantity permitted							
B757-200/300	100 kg (220 lb)							
B757PF/PCF	300 kg (660 lb)							
FI-03	<p>Magnetized material may be loaded in any cargo hold of Icelandair aeroplanes aft of flight deck. Maximum magnetic field strength is 0.002 gauss at 2.1 meter distance from package. Refer to Icelandair Ground Operations Manual.</p>	7;2						
	FX — FEDERAL EXPRESS							
FX-01	<p>Class 1 articles and substances offered on a FedEx International Priority Freight (IPF), FedEx International Premium (IP1), or FedEx International Express Freight (IXF) may require a pre-alert or pre-approval. Call the FedEx Express Freight Customer Service at (800) 332-0807 for additional information (see Packing Instructions 101-143). Any Class 1 shipments originating in a non-U.S. location requires pre-approval. Call your local FedEx customer service number and ask for FedEx Express freight customer service.</p> <p>FedEx Express will not accept for transport any explosives assigned to Division 1.3.</p>	2;1 4;3						
≠	<p>FX-02 Except for UN 1230 — Methanol and excepted quantities, substances with a primary or subsidiary risk of Division 6.1 in Packing Group I or II:</p> <ul style="list-style-type: none"> — with an origin and destination within the U.S., including Puerto Rico, will be accepted only if in approved D.O.T. exemption/special permit (SP) packaging; — will only be accepted for international transport in “V” rated combination packaging. <p>Shippers of Division 6.1, Packing Group III primary or subsidiary risk must indicate “PG III” adjacent to the hazard label on the outer package for shipments to, from, within or transiting the USA.</p> <p>Poison inhalation hazard (PIH) with a hazard zone “A” or any Class 2 substance with a toxic primary or subsidiary risk label will not be accepted for carriage.</p>	2;6 Table 3-1 3;5						

	Identifying code	Variation	Relevant paragraphs
≠	FX-03	<p>Class 7 substances offered on FedEx International Priority Freight (IPF), FedEx International Premium (IP1), or FedEx International Express Freight (IXF) may require a pre-alert or pre-approval. Call (877) 398-5851 for additional information. Plutonium 239 and 241 will not be accepted as UN 3324, UN 3325, UN 3326, UN 3327, UN 3328, UN 3329, UN 3330, UN 3331 or UN 3333.</p> <p>FedEx Express will not accept labelled radioactive material with a subsidiary risk of 1.4, 2.1, 3, 4.1, 4.2, 4.3, 5.1, 5.2, 8 or 2.2 with a “Cargo aircraft only” label unless the shipper has been pre-approved.</p> <p>Class 7 shipments originating in a non-U.S. location require pre-approval. Call your local FedEx customer service number and ask for FedEx Express Freight customer service.</p> <p>All fissile shipments worldwide require pre-approval. Call 1-901-434-3200 for assistance.</p> <p>For mixtures or solutions of radionuclides, enter “mixture” or “solution” as appropriate in the “quantity and type of packaging” field of the shipper’s declaration for dangerous goods in association with the physical and chemical form (e.g. “liquid salt solution” or “solid oxide mixture”).</p>	2;7
	FX-04	<p>The following Class 8 substances will not be accepted for carriage (see packing instructions [–] listed after each substance):</p> <p>UN 1796 — Nitrating acid mixture, over 40 per cent concentration [854] UN 1826 — Nitrating acid mixture, spent over 40 per cent in original solution [854] UN 2031 — Nitric acid over 40 per cent concentration [854, 855].</p> <p>When shipping the above substances in acceptable concentrations, the concentration must be indicated on the shipper’s declaration in association with the proper shipping name.</p>	2;5 Table 3-1
	FX-05	Hazardous waste as defined in US 04, will not be accepted for carriage.	
	FX-06	<p>Polychlorinated biphenyls: The following Class 9 materials, if known or suspected to contain PCBs, must be packaged utilizing as follows:</p> <ul style="list-style-type: none"> — for liquids: IP3 or IP3A inner metal packagings with absorbent material utilized to fill all available space; — for solids: any inner packaging as per applicable packing instruction is permitted. Outer packaging must be a 1A2 steel drum, 4H2 plastic box, USA DOT-SP 8249, 9168 or 11248 (see packing instructions [–] listed after each substance) <p>UN 2315 — Polychlorinated biphenyls, liquid [964] UN 3077 — Environmentally hazardous substances, solid, n.o.s. [956, Y956] UN 3082 — Environmentally hazardous substances, liquid, n.o.s. [964, Y964] UN 3432 — Polychlorinated biphenyls, solid [956].</p>	2;9 4;11 6;1
≠	FX-07	<p>UN 3090 — Lithium metal batteries packed in accordance with Packing Instruction 968 (Section IA, Section IB or Section II) require pre-approval. See www.fedex.com/us; keyword lithium batteries (search field).</p> <p>All lithium batteries packed in accordance with Packing Instructions 965 and 968 (Section IA, Section IB or Section II) and Packing Instructions 966, 967, 969 and 970 (Section I or II) must not be shipped in the same package as the following dangerous goods classes/divisions: 1.4, 2.1, 3, 4.1, 4.2, 4.3, 5.1, 5.2 and 8 and 2.2 with a “Cargo aircraft only” label. This includes all packed in one, overpacks and combination all packed in one/overpacks.</p>	4;11
≠	FX-08	Not used.	
	FX-09	Division 6.2 items classed as Risk Group 4 by the World Health Organization (WHO) will not be accepted for carriage.	2;6

≠	Identifying code	Variation	Relevant paragraphs
	FX-10	All United States domestic shipments of Division 4.3 substances must be offered either under a limited quantity "Y" packing instruction or offered using a Department of Transportation (DOT) special permit that does not require placarding for road transport. Shipments originating in the United States and destined for a non-United States location must be offered under a limited quantity "Y" packing instruction or dropped off at a FedEx Express-staffed facility that accepts dangerous goods. Shipments originating in non-United States locations destined for a United States location must either be offered under a limited quantity "Y" packing instruction or sent as "hold for pickup" at a FedEx Express-staffed facility that accepts dangerous goods.	
	FX-11	Dangerous goods packages that cannot accommodate all of the required Federal Express and regulatory documentation as well as all required regulatory markings and labelling on the top or sides of the outer package will not be accepted for carriage. Any required documentation, marking and labelling will not be permitted on the bottom of the package. FedEx branded packaging, including brown boxes, may not be used to ship dangerous goods or dry ice. Exceptions: <ul style="list-style-type: none"> — FedEx Express white and brown boxes and tubes may be used for FedEx Express Section II lithium battery shipments; and — UN 3373, Biological substance Category B may be shipped in the FedEx UN 3373 Pak and the FedEx Clinical Box. 	
	FX-12	This variation applies only when FX-18 does not apply. Handwritten shipper's declarations will not be accepted. The following fields on the shipper's declaration must be typed or computer-generated: <p>UN or ID number including the prefix, proper shipping name, hazard class or division, subsidiary risk or division(s), packing group, packaging type, packing instruction, authorization and emergency telephone number.</p> <p><i>Note.— The technical name, when required, may be handwritten.</i></p> <p>For radioactive shipments, in addition to the items listed above, the following must also be typed or computer-generated:</p> <p>Radionuclide, special form or physical and chemical form. All other entries may be handwritten.</p> <p>Handwritten alterations/amendments to an entry required to be typed per FX-12 are acceptable if each alteration/amendment is legible and signed with the same signature used to sign the shipper's declaration.</p>	5;4
	FX-13	FedEx Express will only accept Oxygen, compressed (UN 1072) when packed in an ATA Specification 300 Category I outer packaging. Packaging must be marked in accordance with the marking criteria of Air Transportation Association (ATA) Specification No. 300. <p>In addition, FedEx Express will require the outer package to have the additional tested specification mark of DOT31FP (see Packing Instruction 200 and US 15 d)).</p> <p>The additional tested specification mark of DOT31FP will be required in addition to the specification container utilized and marked for all UN numbers listed in US 18 which include UN 3156, UN 3157, UN 2451, UN 1070 and UN 3356.</p>	
	FX-14	When a shipper's declaration is required, three (3) copies must be provided with each shipment at the origin location. At least two of the copies must have the diagonal hatchings printed vertically in the left and right margins and must be printed in red.	5;4
	FX-15	The following substances will not be accepted for carriage (see packing instructions [-] listed after each substance): <ul style="list-style-type: none"> UN 1001 — Acetylene, dissolved [200] UN 1162 — Dimethyldichlorosilane [377] UN 1308 — Zirconium suspended in a flammable liquid, Packing Group I [361] UN 1873 — Perchloric acid, over 50 per cent concentration [553] . 	Table 3-1
	FX-16	FedEx Express will not accept for transport any item with an A2 or A183 Special Provision even with a competent authority approval.	Table 3-1 3;3

Identifying code	Variation	Relevant paragraphs
	<p>FX-17 When using International Economy (IE) or International Economy Freight (IEF) to ship liquids in the primary hazard classes/divisions of 3, 4.2, 5.1, 5.2 and 8, customers must use "V rated" packaging. See www.fedex.com/us; keyword dangerous goods (search field); FedEx services available to ship dangerous goods.</p>	
≠	<p>FX-18 Shippers' declarations for dangerous goods for all FedEx Express® dangerous goods shipments originating in the United States must be prepared using software with dangerous goods compliance edit checks and by one of the following methods:</p> <ul style="list-style-type: none"> — Certain FedEx electronic shipping solutions; — Recognized shipper proprietary software; or — FedEx recognized dangerous goods vendor software. <p>FX-18 currently does not apply to:</p> <ul style="list-style-type: none"> — Shipments originating in non-U.S. locations (including U.S. territories overseas, such as Puerto Rico); — FedEx International, FedEx International Express Freight® (IXF) and FedEx International Premium® (IP1); — Shipments containing Class 7 radioactive materials. <p><i>Note.— A list of FedEx recognized dangerous goods shipping application vendors can be reviewed at www.fedex.com/us; keyword dangerous goods.</i></p>	5;4
>	<p>GA — GARUDA INDONESIA</p> <p>GA-01 Advance arrangements must be made for all shipments of dangerous goods as defined in the IATA Dangerous Goods Regulations.</p> <p>GA-02 Dangerous goods in consolidations will not be accepted for carriage. The only exception is consolidations having one master air waybill with one house air waybill.</p> <p>GA-03 Except for ID 8000 — Consumer commodity, dangerous goods in limited quantities ("Y" packing instructions) will not be accepted for carriage. (See 2.7 of the IATA Dangerous Goods Regulations and all "Y" packing instructions.)</p> <p>GA-04 Material safety data sheet (MSDS) must be provided for dangerous goods except for dangerous goods in Class 7, vehicles, dangerous goods in apparatus or machinery and engines, ID 8000, magnetized material, carbon dioxide, solid (dry ice) and Division 6.2. The MSDS must be written in English.</p> <p>The MSDS must include the UN number, proper shipping name and other relevant transport information.</p>	
+	GA-05 Dangerous goods in excepted quantities will not be accepted for carriage.	3;5
+	GA-06 All combination packagings containing liquid dangerous goods in Packing Group I, II or III must contain sufficient absorbent material to absorb the entire contents of all the inner packagings.	4;1
+	GA-07 Prior authorization from BAPETEN is required for the transportation of radioactive material to, from and through Indonesia territory by Garuda Indonesia (see Appendix D.2 of the IATA Dangerous Goods Regulations).	5;1.2 7;1
+	GA-08 Single packagings containing liquid dangerous goods are not acceptable for transport unless overpacked by placing the packages on a suitably-sized plastic, foam or wooden pallet to protect the base of the packaging.	4;1
+	GA-09 Overpacks that completely cover the package(s) inside the overpack will not be accepted for carriage.	

<i>Identifying code</i>	<i>Variation</i>	<i>Relevant paragraphs</i>
+	GA-10 The shipper must provide a 24-hour emergency telephone number of a person that has knowledge of the hazards, characteristics and action to be taken in the event of an accident or incident concerning all dangerous goods being transported by air. The telephone number, which must include the country and area code, should be shown in the additional handling information box of the shipper's declaration for dangerous goods and on the package. A 24-hour emergency telephone number is not required for shipments that do not require a shipper's declaration for dangerous goods.	5;4
	GF — GULF AIR	
	GF-01 Only explosives of Division 1.4S are acceptable for carriage and only with prior approval from Gulf Air.	2;1 Table 3-1
	GF-02 Prior approval is required for the carriage of munitions of war, sporting weapons and ammunition.	2;1 Table 3-1
	GF-03 The carriage of dangerous goods in excepted quantities is restricted. Apply to Gulf Air for details.	3;5
	GF-04 The carriage of limited quantities of dangerous goods ("Y" packing instructions) is not permitted.	3;4
≠	GF-05 Interline transfer of dangerous goods will only be accepted if a copy of the acceptance checklist accompanies the consignment together with the shipper's declaration for dangerous goods (DGD) and the air waybill (see 9.1.3 of the IATA Dangerous Goods Regulations).	7;2.4
	GF-06 The shipper must provide a 24-hour emergency telephone number of a person/agency who is knowledgeable of the hazards, characteristics and actions to be taken in the case of an accident or incident concerning each of the dangerous goods being transported. This telephone number, including the country and area code, preceded by the words "Emergency contact" or "24-hour number", must be inserted on the DGD, preferably in the "Handling information" box, e.g. "Emergency contact: +47 67 50 00 00".	5;4
	GF-07 Fissile radioactive material in any quantity will not be accepted for carriage on GF services.	2;7 Table 3-1
+	GF-08 Salvage packagings will not be accepted for carriage on GF aircraft (see 7.1.4 and 7.2.3.10 of the IATA Dangerous Goods Regulations).	4;1.4 5;1.5
+	GF-09 Division 6.2 — Infectious substances of Category A affecting animals (UN 2900) or humans (UN 2814) will be accepted only with prior approval (see Packing Instruction 620).	2;6 4.8
+	GF-10 Class 7 — Radioactive material of Category I, II, or III will be accepted for carriage provided the total transport index (TI) in one package or in a group of packages must not exceed 3.0 for narrow-bodied aircraft and 8.0 for wide-bodied aircraft. This restriction applies to total TI per aircraft. Apply to GF.	2;7
+	GF-11 UN 1845 — Carbon dioxide, solid/dry ice which is shipped by itself or used as a refrigerant will be restricted to a maximum of 200 kg per hold on any GF aircraft. (See 9.3.11 and Packing Instruction 954 of the IATA Dangerous Goods Regulations).	4;11 7;2.12
+	GF-12 Not used.	
+	GF-13 Wheelchairs or other battery-powered mobility devices with spillable batteries will be accepted only when the battery is removed from the wheelchair or mobility device. The spillable battery, classified as dangerous goods, can only be carried as cargo (see 2.3.2.3 and 9.3.15 of the IATA Dangerous Goods Regulations). Batteries attached to or installed in the wheelchair or mobility device will not be accepted (see 9.3.15 of the IATA Dangerous Goods Regulations).	8;1
+	GF-14 Lithium metal or lithium alloy cells and batteries (UN 3090) and lithium metal or lithium alloy cells and batteries packed with or contained in equipment (UN 3091) are prohibited from carriage as cargo on GF aircraft. This prohibition does not apply to GF company material (see Packing Instructions 968, 969 and 970).	4;11

<i>Identifying code</i>	<i>Variation</i>	<i>Relevant paragraphs</i>
+	GF-15 Dangerous goods in airmail will not be accepted for carriage (see 2.4 of the IATA Dangerous Goods Regulations).	1;2,3
+	GF-16 Prior approval is required to carry dangerous goods of Classes 1, 3, 8 and Division 2.1 as defined in these Instructions on all GF narrow-bodied aircraft aft hold.	2;1 2;2 2;3 2.8
GH — LLC GLOBUS		
GH-01	Shipment of dangerous goods transported by Llc GloBus will only be acceptable after getting advance approval from Llc GloBus. Requests for dangerous goods shipments must be made on the special form of approval (form is provided by request) and sent to the following email address: cgo@s7.ru . The form of approval is to be attached to the set of accompanying documents and forwarded on board to the crew by the handling company at the airport of departure.	5;4 7;4
GH-02	Patient specimens will only be accepted if assigned to UN 2814 or UN 2900 or UN 3373 as appropriate. Biological substance, Category B — UN 3373 may only be accepted for carriage under necessary requirements and after a prior Llc GloBus written approval has been granted.	2;6 Table 3-1
GH-03	The shipper must provide a 24-hour emergency telephone number of a person/agency who is knowledgeable of the hazards, characteristics and actions to be taken in case of an accident or incident concerning each of the dangerous goods being transported. This telephone number, including the country and area code, preceded by the words "Emergency Contact" or "24-hour number" must be inserted on the shipper's declaration for dangerous goods (DGD) in the "Additional Handling Information" box, e.g. "Emergency Contact +7 495 123 45 78".	5;4
GL — MIAMI AIR INTERNATIONAL		
GL-01	Prior approval is required for shipments containing mercury.	
HA — HAWAIIAN AIRLINES		
HA-01	Division 6.1 — Toxic substances are not accepted for carriage.	2;6 Table 3-1
HA-02	Division 2.3 — Toxic gases are not accepted for carriage.	2;2 Table 3-1
HA-03	Division 6.2 — Infectious substances are not accepted for carriage.	2;6 Table 3-1
HA-04	Class 7 — Radioactive material of any kind will not be accepted for carriage.	
HF — TUIFLY		
HF-01	Class 7 — Fissile radioactive material will not be accepted for carriage on HF flights.	2;7 Table 3-1
+	HQ — THOMAS COOK AIRLINES	
HQ-01	Class 7 — Radioactive material of any kind will not be accepted for carriage (see 10.10.2 of the IATA Dangerous Goods Regulations).	2;7
HQ-02	Battery-powered wheelchairs or mobility aids with spillable batteries will not be accepted (see 2.3.2.3 and 9.3.15 of the IATA Dangerous Goods Regulations).	8;1
HQ-03	Non-infectious specimens packed with small quantities of flammable liquid are not allowed on HQ aircraft as dangerous goods carried by passengers or crew (see 2.3.5.14 of the IATA Dangerous Goods Regulations)	8;1
HQ-04	Permeation devices are not allowed on HQ aircraft as dangerous goods carried by passengers or crew (see 2.3.5.16 of the IATA Dangerous Goods Regulations)	8;1

<i>Identifying code</i>	<i>Variation</i>	<i>Relevant paragraphs</i>
	HV — TRANSAVIA AIRLINES C.V.	
HV-01	Class 7 — Radioactive material is not accepted for carriage.	2;7 Table 3-1
+	HX — HONG KONG AIRLINES	
HX-01	Dangerous goods in excepted quantities will not be accepted for carriage (see 2.6 of the IATA Dangerous Goods Regulations).	3;5
HX-02	Excepted packages of radioactive material will not be accepted for carriage (see 10.5.8 of the IATA Dangerous Goods Regulations).	1;6.1.5
HX-03	Interline transfer of dangerous goods will not be accepted for carriage.	7;1
HX-04	Dangerous goods in airmail will not be accepted for carriage.	1;2.3
HX-05	Dangerous goods in consolidations will not be accepted for carriage, except for: <ul style="list-style-type: none"> — consolidations containing UN 1845 — Carbon dioxide, solid (dry ice) when used as a refrigerant; and — consolidations with only one house air waybill. 	7;1
HX-06	Lithium metal batteries (UN 3090). Lithium metal cells and batteries will not be accepted for carriage. This prohibition applies to Section IA, Section IB and Section II of Packing Instruction 968.	Table 3-1 4;11
≠	IB — IBERIA, LÍNEAS AÉREAS DE ESPAÑA	
IB-01	UN 3090 — Lithium metal batteries. Primary (non-rechargeable) lithium (metal) batteries and cells are prohibited from carriage as cargo on passenger aircraft. (See Packing Instruction 968.) This prohibition does not apply to: <ul style="list-style-type: none"> — UN 3091, UN 3480, UN 3481; — lithium batteries (rechargeable and non-rechargeable) covered by the provisions for dangerous goods carried by passengers or crew. (See Table 2.3.A of the IATA Dangerous Goods Regulations.) 	Table 3-1 4;11 8;1
IB-02	Infectious substances (UN 2814, UN 2900 and UN 3373) and biological products are not accepted for carriage in mail.	1;2.3 2;6 Table 3-1
IB-03	Hazardous waste in any form, as defined by any regulation, will not be accepted for carriage. (See Packing Instruction 622 and 8.1.3.3 of the IATA Dangerous Goods Regulations).	4;8 5;1.1
IB-04	Class 7 — Fissile radioactive material will not be accepted for carriage on passenger aircraft.	2;7 Table 3-1
	IG — MERIDIANA	
IG-01	Class 1 explosives will not be accepted for carriage, except for Division 1.4S UN 0323 — Cartridges, power device as COMAT. Ammunition for hunting or sporting purposes only may be transported in checked baggage (see 4;3).	Table 3-1
IG-02	UN 1845 — Carbon dioxide, solid (dry ice) is restricted to 200 kg per aircraft hold.	Table 3-1 7;2
	IJ — GREAT WALL AIRLINES	
IJ-01	Only explosives of Division 1.4S and Division 1.4G can be accepted for carriage on GWL services. Explosives of Division 1.4S must be packed for passenger aircraft. Explosives of Division 1.4G can only be uplifted from Shanghai.	2;1 Table 3-1
IJ-02	Items with a primary or subsidiary risk of Division 2.1, Class 4 and Class 5, when packed for cargo aircraft only, will not be accepted for carriage.	2;2, 2;3, 2;4, 2;5 Table 3-1

<i>Identifying code</i>	<i>Variation</i>	<i>Relevant paragraphs</i>
IJ-03	Class 7 — Fissile material (uranium-233/235 and plutonium-238/239/241) will not be accepted on any aircraft.	2;7 Table 3-1
IJ-04	Dangerous goods sent as airmail will not be accepted for uplift.	1;2,3
IJ-05	Oxygen generators, chemical (UN 3356) will not be accepted on any aircraft.	Table 3-1
IJ-06	Infected animals, dead or alive, will not be accepted for carriage.	2;6
IJ-07	Dangerous goods in excepted quantities originating from China will not be accepted for carriage. However, this prohibition does not apply to radioactive materials in excepted packages.	3;5
IJ-08	The shipper must provide a 24-hour emergency telephone number of a person/agency who is knowledgeable of the hazards, characteristics and actions to be taken in case of an accident or incident concerning (each of) the dangerous goods being transported. This telephone number, including country and area code, preceded by the words "Emergency contact" or "24-hour number" must be inserted on the shipper's declaration for dangerous goods (DGD) preferably in the "Additional handling information" box, e.g. "Emergency contact +47 67 50 00 00". A 24-hour emergency telephone number is not required for shipments that do not require a DGD.	5;4
IJ-09	Dangerous goods shipments from other carriers will not be accepted unless prior special arrangements have been made with IJ. For more details, please refer to IJ Ground Services Department.	
IJ-10	Biological substance, Category B (UN 3373), will not be accepted.	Table 3-1
IJ-11	Dangerous goods in consolidations will not be accepted for carriage, except for: <ul style="list-style-type: none"> — consolidations containing UN 1845 — Carbon dioxide, solid (dry ice) when used as a refrigerant; and — consolidations with only one house air waybill. 	
IJ-12	Dangerous goods in "limited quantities" ("Y" packing instructions) will not be accepted for carriage. (See 2.7 of the IATA Dangerous Goods Regulations and all "Y" packing instructions).	3;4
IJ-13	Only Division 6.2, Class 7 and Class 9, will be uplifted into/over the United States.	2;6, 2;7, 2;9
IP — IBERWORLD AIRLINES		
IP-01	Dangerous goods in excepted quantities will not be accepted for carriage.	3;5
IP-02	Consolidated dangerous goods will not be accepted for carriage.	7;1
IP-03	Infected animals, dead or alive, will not be accepted for carriage.	2;6 Table 3-1
≠ IP-04	Class 7 — Radioactive material will not be accepted for carriage.	2;7 Table 3-1
IP-05	Wheelchairs with spillable batteries will not be accepted for carriage.	8;1
IP-06	Carbon dioxide, solid (dry ice), as cargo, will not be accepted as cargo.	2;9 Table 3-1
IR — IRAN AIR		
IR-01	Not used.	
IR-02	Dangerous goods in consolidations will not be accepted for carriage, except for carbon dioxide, solid (dry ice) when used as a refrigerant.	7;1
IR-03	All package and overpack markings required by these Instructions must be in English. If the State of Origin requires markings in a language other than English, both languages are to be given equal prominence.	5;2,5

<i>Identifying code</i>	<i>Variation</i>	<i>Relevant paragraphs</i>
IR-04	<p>Carriage of Class 1 — Explosives on Iran Air flights is strictly prohibited with the exception of:</p> <ul style="list-style-type: none"> — cartridges, power device, UN 0323, Division 1.4S, Packing Instruction 134, will only be accepted for Iran Air use as aircraft spare parts (A.O.G.). <ul style="list-style-type: none"> — maximum 2 kg per package on passenger aircraft; — maximum 5 kg per package on cargo aircraft. — cartridges for sporting purposes, UN 0012 and UN 0014, Division 1.4S, Packing Instruction 130, will be accepted as cargo when limited to: <ul style="list-style-type: none"> — maximum 5 kg per package on passenger aircraft; — maximum 25 kg per package on cargo aircraft. 	2;1 Table 3-1
IR-05	<p>Oxygen generators (chemical) under the following descriptions will not be accepted for carriage (see packing instructions [-] listed after each substance):</p> <ul style="list-style-type: none"> UN 1325 — Flammable solid, organic, n.o.s.* (Division 4.1) [445, 448, Y441, 446, 449, Y443] UN 1449 — Barium peroxide (Division 5.1, Subsidiary risk 6.1) [558, 562, Y543] UN 1479 — Oxidizing solid, n.o.s.* (Division 5.1) [557, 561, 558, 562, Y544, 559, 563, Y546] UN 1489 — Potassium perchlorate (Division 5.1) [558, 562, Y544] UN 1491 — Potassium peroxide (Division 5.1) [561] UN 1495 — Sodium chlorate (Division 5.1) [558, 562, Y544] UN 1504 — Sodium peroxide (Division 5.1) [561] UN 2466 — Potassium superoxide (Division 5.1) [561] UN 2547 — Sodium superoxide (Division 5.1) [561] UN 3356 — Oxygen generator, chemical (Division 5.1) [565]. <p>All carriage of oxygen generators containing substances such as iron powder, iron dust, silicon dioxide and manganese dioxide, which do not have specific proper shipping names, are prohibited.</p>	2;5 Table 3-1
IR-06	<p>The following dangerous goods will not be accepted for carriage on Iran Air (see packing instructions [-] listed after each substance):</p> <ul style="list-style-type: none"> UN 1040 — Ethylene oxide [200] UN 1063 — Methyl chloride (Division 2.1) [200] UN 1261 — Nitromethane [364] UN 1294 — Toluene (Class 3) [353, 364, Y341] UN 1410 — Lithium aluminium hydride [487] UN 1715 — Acetic anhydride (Class 8) [851, 855, Y840] UN 1739 — Benzyl chloroformate [854] UN 1786 — Hydrofluoric acid and sulphuric acid mixture [854] UN 1838 — Titanium tetrachloride [-] UN 1950 — Aerosols, flammable gas and corrosive (Division 2.1) [203, Y203] UN 2428 — Sodium chlorate, aqueous solution (Division 5.1) [550, 554, Y540, 551, 555, Y541] UN 2495 — Iodine pentafluoride [-] UN 2806 — Lithium nitride (Division 4.3) [488]. 	Table 3-1

>

IY — YEMEN AIRWAYS

IY-01	Shippers wishing to ship dangerous goods shipment to Yemen must give an undertaking stating that the consignee will take delivery in Yemen within 15 days of arrival of the shipment. Otherwise shippers will take back their shipments at their own cost.
-------	--

Identifying code	Variation	Relevant paragraphs
JJ — TAM AIRLINES		
≠	<p data-bbox="261 289 1239 384">JJ-01 Dangerous goods offered for transport under an approval or an exemption as provided by 1.2.5 and 1.2.6 of the IATA Dangerous Goods Regulations and any other TAM Airlines conditions by pre-approval will be accepted only after prior review and approval of the LATAM Dangerous Goods Technical Committee.</p> <p data-bbox="367 411 1239 485">In addition, UN 1040 and UN 2014, when shipped as excepted quantities in accordance with Special Provisions A131 and A75 respectively, also require prior review and approval of the LATAM Dangerous Goods Technical Committee.</p> <p data-bbox="367 506 1239 600">An application for approval must be undertaken at least fifteen working days in advance of the scheduled date for the flight. The material safety data sheet (MSDS) or other documentation that covers the shipment must be attached. Applications should be addressed to:</p> <p data-bbox="404 621 1138 741">TAM Dangerous Goods Department Telephone: +55 11 55827626 +56-2-2677-4571/+56-2-25669366 +1-305-772-2894 Email: saofy@tam.com.br and DangerousGoodsBoard@lan.com</p>	1;1.1
JJ-02	<p data-bbox="367 758 1239 926">The shipper must provide a 24-hour emergency telephone number of a person/agency who is knowledgeable of the hazards, characteristics and actions to be taken in case of an accident or incident concerning each of the dangerous goods being transported. This telephone number, including the country and area code, preceded by the words "Emergency contact" or "24-hour number" must be inserted on the declaration for dangerous goods in the "Handling Information" box. (See 8.1.6.11 and 10.8.3.11 of the IATA Dangerous Goods Regulations.)</p> <p data-bbox="367 947 987 968">An emergency response telephone number is not required for:</p> <ul data-bbox="404 999 1239 1230" style="list-style-type: none"> — battery-powered equipment; — battery-powered vehicle; — flammable gas-powered vehicle; — flammable liquid-powered vehicle; — engine, internal combustion; — dangerous goods in limited quantities as described in 3;4 of these Instructions (2.7 of the IATA Dangerous Goods Regulations); — carbon dioxide, solid (dry ice); — consumer commodity; and — refrigerating machines. 	Table 3-1 5;4
JJ-03	<p data-bbox="367 1251 1239 1304">For toxic substances of Division 6.1 or Division 2.3, the following requirements must be complied with:</p> <ul data-bbox="404 1325 1239 1461" style="list-style-type: none"> a) Toxic substances of Division 6.1, Packing Group I, that are toxic by inhalation, will not be accepted for carriage unless a prior approval has been obtained (see LA-01). b) Toxic gases of Division 2.3 will not be accepted for carriage unless a prior approval has been obtained (see LA-01). 	2;3 2;6 5;4 6;1

Identifying code	Variation	Relevant paragraphs
	<p>c) When the substance to be carried has an inhalation, mist, powder or vapour hazard, the shipper's declaration must have the following endorsement in the "Additional handling information box": "Mist, powder or vapour inhalation hazard", as appropriate.</p> <p><i>Note 1.— This requirement only applies to the primary risk.</i></p> <p><i>Note 2.— Where the substance has more than one route of toxicity, the risk that determined the packing group must be used.</i></p> <p>d) Solid toxic substances of any kind will not be accepted for carriage in bags 5H1, 5H2, 5H3, 5H4, 5L2, 5L3, 5M1 or 5M2 as single packagings unless contained in a strong hot sealed polyethylene bag at least 200 microns thick. If these types of packages are offered overpacked in a warehouse pallet, they will be accepted for carriage provided:</p> <ol style="list-style-type: none"> 1) the warehouse pallet is rigid and strong enough to support the weight assembled on it, without bending when picked up and transported by a forklift; 2) the surface of the warehouse pallet is continuous, soft and free of sharp protruding points which could pierce the bags; and 3) the warehouse pallet is provided with separation bars from the floor for the use of a forklift. 	
JJ-04	<p>Infectious substances will be accepted under specific advance arrangements and the following requirements must be met:</p> <ol style="list-style-type: none"> a) The shipper must prove by a document such as a fax, telex, letter, etc., that the infectious substance can legally enter the State of Destination and that all the requirements of the States of Origin and Destination of the shipment have been complied with. b) The shipper must attach a certificate duly signed and issued by a medical, scientific or other similar professional which confirms the classification of these specimens in the following cases: <ul style="list-style-type: none"> — shipment of Biological substance, Category B; — shipment of any patient specimens prepared according to 3.6.2.2.3.6 of the IATA Dangerous Goods Regulations. c) Infected animals, dead (whole bodies) or alive will not be accepted for carriage. 	2;6.3.2.3.6 5;4
JJ-05	Formaldehyde solutions containing less than 25% of formaldehyde must be shipped under UN 3334 — Aviation regulated liquid, n.o.s.*, Class 9, Packing Group III.	Table 3-1
JJ-06	The marking required by 7.1.5 of the IATA Dangerous Goods Regulations and application of hazard and handling labels on packages containing dangerous goods must not be applied to the top or bottom of packages. These markings and labels must be applied to the sides of packages. This requirement does not apply to marking of the full name and address of the shipper and consignee.	5;2 5;3
JJ-07	Fissile material as defined in 10.3.7 of the IATA Dangerous Goods Regulations will be accepted only with prior review and approval by the LAN Dangerous Goods Technical Committee (see LA-01).	1;6.1.5 2;7
+	<p>JJ-08 UN 3090 — Lithium metal batteries and UN 3091 — Lithium metal batteries contained in or packed with equipment. Primary (non-rechargeable) lithium (metal) batteries and cells must be transported on cargo aircraft only (CAO).</p> <p>This prohibition does not apply to:</p> <ul style="list-style-type: none"> — lithium batteries (rechargeable and non-rechargeable) covered by the provisions for dangerous goods carried by passengers or crew. (See Table 2.3.A of the IATA Dangerous Goods Regulations.) — lithium metal batteries and cells contained in medical equipment being transported for humanitarian reasons. 	Table 3-1 4;11 8;1

<i>Identifying code</i>	<i>Variation</i>	<i>Relevant paragraphs</i>
	— lithium metal batteries and cells that are presented as COMAT of any air company of LATAM Airlines Group.	
+	<p>JJ-09 Unit load devices or freight containers containing dangerous goods described in 9.1.4, sub-paragraphs (a) to (d) of the IATA Dangerous Goods Regulations or lithium batteries prepared under Section II of Packing Instructions 965 to 970 will be accepted by advance arrangements and contract only in accordance with the current “Accreditation Freight Forwarder Programme” implemented by the TAM Dangerous Goods Department (see JJ-01).</p> <p>The shipper/freight forwarder must deliver a document certifying that:</p> <ul style="list-style-type: none"> — the shipment was prepared on secure premises and protected against unlawful interference during preparation, storage and transport; and — packages comply with all requirements of the IATA Dangerous Goods Regulations. 	7;1.4
+	<p>JJ-10 UN 3356 — Chemical oxygen generators transported to, from, through or within the United States must be placed in outer packaging that bears the additional tested specification mark of DOT 31FP indicating compliance with 49 CFR 173.168.</p>	4;7
JL — JAPAN AIRLINES		
	JL-01 Not used.	
	JL-02 Not used.	
	JL-03 Type B(M) or fissile material packages and/or any SCO or LSA materials in industrial packagings will not be accepted for carriage.	2;7 Table 3-1
	JL-04 Not used.	
	JL-05 No Type B(U) packages will be accepted for carriage on passenger aircraft unless they are intended for use in, or incident to, medical diagnosis, treatment or research.	2;7 Table 3-1
	<p>JL-06 Magnetized material will not be carried aboard an aircraft if the net weight of the magnet itself exceeds:</p> <ul style="list-style-type: none"> — 2 000 kg or 4 400 lb in each unit load device (ULD) and bulk compartment (B-747F or B-747 aircraft); — 2 000 kg or 4 400 lb in each unit load device (ULD) and bulk compartment (B-767F or B-767 aircraft); — 2 000 kg or 4 400 lb in each unit load device (ULD) and bulk compartment (B-777 aircraft); or — 600 kg or 1 320 lb in one aircraft (B-737 aircraft). 	2;9 7;2
	JL-07 Not used.	
	JL-08 Division 6.1 — Toxic substances in Packing Group I will not be accepted for carriage.	2;6 Table 3-1
≠	<p>JL-09 Liquid dangerous goods in single packagings of steel drums (1A1 or 1A2) and steel jerricans (3A1 or 3A2) will not be accepted unless overpacked with suitable material to protect at least the top and bottom of the packaging.</p>	6;1
	JL-10 Not used.	
	<p>JL-11 The shipper must provide a 24-hour emergency telephone number of a person/agency who is knowledgeable of the hazards, characteristics and actions to be taken in the case of an accident or incident concerning each of the dangerous goods being transported. This telephone number, including the country and area code, preceded by the words “Emergency contact” or “24-hour number”, must be inserted on the shipper’s declaration for dangerous goods (DGD), preferably in the “Handling information” box, e.g. “Emergency contact +47 67 50 00 00”. (See 8.1.6.11 and 10.8.3.11 of the IATA Dangerous Goods Regulations.)</p> <p>A 24-hour emergency telephone number is not required for shipments that do not require a DGD.</p>	5;4

<i>Identifying code</i>	<i>Variation</i>	<i>Relevant paragraphs</i>
JP — ADRIA AIRWAYS		
≠	<p>JP-01 All dangerous goods as defined by these Instructions are forbidden for carriage as cargo on board Adria Airways Services. This prohibition includes:</p> <ul style="list-style-type: none"> — dangerous goods in excepted quantities (REQ) or de minimis quantities; — radioactive material in excepted packages (RRE); — UN 1845 — Carbon dioxide, solid (dry ice) (ICE), pure and when used as a refrigerant for non-dangerous cargo; — UN 3373 — Biological substances, Category B (RDS); — Lithium ion batteries as per Sections IA and IB of Packing Instruction 965 and Section I of Packing Instructions 966 to 967 (RLI); — Lithium ion batteries as per Section II of Packing Instructions 965 to 967 (ELI); — Lithium metal batteries as per Sections IA and IB of Packing Instruction 968 and Section I of Packing Instructions 969 to 970 (RLM); and — Lithium metal batteries as per Section II of Packing Instructions 968 to 970 (ELM). <p>See 1.3.2 and 9.1.2 of the IATA Dangerous Goods Regulations.</p>	1;6 Table 3-1 3;5 4;11 5;1.1 5;1.3 5;1.4 7;1.2
+	<p>JP-02 Dangerous goods are forbidden for carriage in airmail on board Adria Airways services. This prohibition includes all dangerous goods exceptions permitted by the Universal Postal Union (UPU) listed in 2.4.2 (a), (b), (c), (d) and (e) of the IATA Dangerous Goods Regulations.</p>	1;2.3
+	<p>JP-03 The following dangerous goods are forbidden to be carried by passengers on board Adria Airways services:</p> <ul style="list-style-type: none"> — spillable (lead-acid) batteries even when used for powering wheelchairs or other mobility devices; and — cylinders containing compressed oxygen even when required for medical use. 	8;1
JQ — JETSTAR		
	<p>JQ-01 Not used.</p>	
≠	<p>JQ-02 Division 4.1 — Flammable solids. Passengers and crew are not permitted to bring book matches onto aircraft for personal use. Book matches are only allowed as correctly packed and declared dangerous goods consignments.</p>	8;1
+	<p>JQ-03 Operator approval is required for the carriage of all new and used internal combustion engines (see 2.3.5.15 of the IATA Dangerous Goods Regulations).</p>	8;1
+	<p>JQ-04 Oxygen or air, gaseous cylinders required for medical use are only accepted for transport in or as carry-on baggage (see 2.3.4.1 of the IATA Dangerous Goods Regulations).</p>	8;1
JU — JAT AIRWAYS		
≠	<p>JU-01 Advance arrangements must be made for all shipments of dangerous goods as defined in the IATA Dangerous Goods Regulations.</p>	
≠	<p>JU-02 Transport of dangerous goods (all classes) is forbidden on aircraft type ATR 72.</p>	
≠	<p>JU-03 Dangerous goods as defined in the IATA Dangerous Goods Regulations will not be accepted in airmail.</p>	1;2.3
≠	<p>JU-04 Hazardous waste in any form, as defined by any regulations, will not be accepted.</p>	

	<i>Identifying code</i>	<i>Variation</i>	<i>Relevant paragraphs</i>
≠	JU-05	<p>Class 7 — Radioactive material of categories I-White, II-Yellow and III-Yellow will be accepted for carriage aboard passenger aircraft provided the following conditions are complied with:</p> <ul style="list-style-type: none"> — the total transport index (TI) in a group of packages or in one package must not exceed 3.0 per aircraft; and — the shipper's declaration accompanying each shipment of radioactive material of categories White-I, Yellow-II or Yellow-III must show the following endorsement in the handling information box: "Radioactive material is intended for use in, or incidental to, medical research, diagnosis or treatment". 	2;7 Table 3-1 5;4
+	JU-06	Dangerous goods in limited quantities ("Y" packing instructions) will not be accepted for carriage.	3;4
+	JU-07	Dangerous goods in consolidations will not be accepted for carriage.	7;1
+	JU-08	The carriage of UN 1845 — Carbon dioxide, solid (dry ice) will be limited to not more than 100 kg net quantity per hold.	7;2
+	JU-09	Material safety data sheets (MSDS) are required for dangerous goods whether in export, import or transit.	5;4
+	JU-10	Wheelchairs or other battery-powered mobility devices with spillable batteries will not be accepted for carriage.	8;1
+	JU-11	Small gaseous oxygen or air cylinders required for medical use will only be accepted empty as checked baggage with the approval of Jat Airways. Should a passenger require supplementary oxygen, this will be provided by the operator at a cost with prior arrangements. (See 2.3.4.1 of the IATA Dangerous Goods Regulations.)	8;1
+	JU-12	The shipper must provide a 24-hour emergency telephone number of a person/agency who is knowledgeable of the hazards, characteristics and actions to be taken in the case of an accident or incident concerning each of the dangerous goods being transported. This telephone number, including the country and area code, preceded by the words "Emergency Contact" or "24-hour number" must be inserted on the shipper's declaration for dangerous goods, preferably in the "Handling Information" box, e.g. "Emergency Contact +381 11 10 00 00" (see 8.1.6.11 and 10.8.3.11 of the IATA Dangerous Goods Regulations).	5;4
JW — SKIPPERS AVIATION			
	JW-01	All hazard labels must include text indicating the nature of the risk. This text must appear prominently in English in the lower half of the label as described in 7.2.2.4 of the IATA Dangerous Goods Regulations. If the State of Origin requires text in a language other than English, both languages are to be given equal prominence.	5;3.3
	JW-02	Division 4.1 — Flammable solids. Passengers and crew are not permitted to bring book matches onto aircraft for personal use. Book matches are only allowed as correctly packed and declared dangerous goods consignments.	8;1
	JW-03	Not used.	
	JW-04	Division 5.2 — Organic peroxide. No substance required to bear an "Organic peroxide" hazard label will be accepted for carriage.	2;5 Table 3-1
JX — JETT8 AIRLINES CARGO			
	JX-01	Class 7 — Fissile material will not be accepted.	2;7
	JX-02	<p>The shipper must provide a 24-hour emergency telephone number of a person/agency who is knowledgeable of the hazards, characteristics and actions to be taken in case of an accident or incident concerning (each of) the dangerous goods being transported. This telephone number, including country and area code, preceded by the words "Emergency contact" or "24-hour number" must be inserted on the shipper's declaration for dangerous goods (DGD) preferably in the "Handling information" box, e.g. "Emergency contact +47 67 50 00 00".</p> <p>A 24-hour emergency telephone number is not required for shipments that do not require a DGD.</p>	5;4

<i>Identifying code</i>	<i>Variation</i>	<i>Relevant paragraphs</i>
JX-03	Dangerous goods in excepted quantities will not be accepted. (See 2.6 of the IATA Dangerous Goods Regulations.)	3;5
JX-04	Dangerous goods in salvage packagings will not be accepted for carriage. (See 5.0.1.6, 6.0.7, 6.7, 7.14, 7.2.3.11 of the IATA Dangerous Goods Regulations.)	4;1.4 5;1.5 5;2.4 6;1.2.6 6;2.3 6;4.8
KA — HONG KONG DRAGON AIRLINES (DRAGONAIR)		
KA-01	Not used.	
KA-02	All combination packagings containing liquid dangerous goods in Packing Group I, II or III must contain sufficient absorbent material to absorb the entire contents of all the inner packagings.	4;1
KA-03	Not used.	
KA-04	The shipper must provide a 24-hour emergency telephone number of a person/agency who is knowledgeable of the hazards, characteristics and actions to be taken in case of an accident or incident concerning (each of) the dangerous goods being transported. This telephone number, including the country and area code, preceded by the words "Emergency contact" or "24-hour number" must be inserted on the shipper's declaration for dangerous goods (DGD) preferably in the "Additional handling information" box, e.g. "Emergency contact +47 67 50 00 00". (See 8.1.6.11 and 10.8.3.11 of the IATA Dangerous Goods Regulations.) A 24-hour emergency telephone number is not required for shipments that do not require a DGD.	5;4
KA-05	Liquid substances in single packagings of drums or jerricans of any material must be prepared as follows: 1) the steel drums/plastic drums/plastic jerricans must be protected by other strong outer packaging such as a fibreboard box; or 2) if prepared as an open overpack, a suitably-sized plastic, foam or wooden pallet must be used to protect at least the top and bottom of the packaging.	2;8
KA-06	In addition to the requirements in 8.2.5 of the IATA Dangerous Goods Regulations, UN number(s) of all shipments of dangerous goods in excepted quantities must be indicated on the air waybill.	5;4
KA-07	Lithium metal batteries (UN 3090). Lithium metal cells and batteries are prohibited from carriage as cargo on Dragonair aircraft. This prohibition applies to Section IA, Section IB and Section II of Packing Instruction 968. This prohibition does not apply to: — lithium metal cells and batteries packed with or contained in equipment (UN 3091) in accordance with Packing Instruction 969 or 970; — lithium ion cells and batteries (UN 3480 and UN 3481) in accordance with Packing Instruction 965, 966 or 967; or — lithium batteries (rechargeable and non-rechargeable) covered by the Provisions for Dangerous Goods Carried by Passengers or Crew. (See 2.3.2 to 2.3.5 and Table 2.3.A of the IATA Dangerous Goods Regulations and Part 8 of these Instructions.)	Table 3-1 4;11 8;1
KA-08	All shipments of lithium batteries contained in equipment prepared in accordance with Section II of Packing Instruction 967 or 970 must include the mandatory wording on the air waybill as shown in Section II ("lithium ion batteries, in compliance with Section II of PI967" or "lithium metal batteries, in compliance with Section II of PI970"). This applies even to shipments where no lithium battery handling label is required to be affixed to the package(s).	4;11

<i>Identifying code</i>	<i>Variation</i>	<i>Relevant paragraphs</i>
KC — AIR ASTANA		
KC-01	<p>The shipper must provide a 24-hour emergency telephone number of a person/agency who is knowledgeable of the hazards, characteristics and actions to be taken in case of an accident or incident concerning (each of) the dangerous goods being transported. This telephone number, including country and area code, preceded by the words "Emergency contact" or "24-hour number" must be inserted on the shipper's declaration for dangerous goods (DGD) preferably in the "Additional handling information" box, e.g. "Emergency contact +47 67 50 00 00".</p> <p>A 24-hour emergency telephone number is not required for shipments that do not require a DGD.</p>	5;4
≠	<p>KC-02 The following classes are accepted for carriage without prior permission from the KC head office:</p> <ul style="list-style-type: none"> — Class 1 — Explosives, only ammunition permitted in accordance with the provisions for dangerous goods carried by passengers or crew. (See 2.3 of the IATA Dangerous Goods Regulations and Part 8 of these Instructions.) — Division 2.2 — Non-flammable, non-toxic gas — Class 3 — Flammable liquids — Class 8 — Corrosives — Class 9 — Miscellaneous <p>For carriage of other classes and divisions, the local cargo sales office and/or KC cargo sales head office (cargo@airastana.com) should be contacted in advance during office working hours.</p>	8;1
KC-03	<p>The carriage of UN 1845 — Carbon dioxide, solid (dry ice) will be limited to the following:</p> <ul style="list-style-type: none"> — A319/A320/A321 — 250 kg per aircraft (in AFT compartment only); and — B757/B767 — 200 kg per aircraft (100 kg in FWD compartment; 100 kg in AFT compartment). 	Table 3-1
KC-04	The carriage of dangerous goods on board Fokker-50 aircraft is prohibited.	
KC-05	The operative telephone or facsimile number of the consignee must be shown on the air waybill.	5;4
KC-06	Single packagings containing liquid dangerous goods are not acceptable for transport unless overpacked with, for example, a suitable sized wooden pallet to protect at least the top and bottom of the packagings.	4;1
KC-07	All hazard labels must include text indicating the nature of the risk.	5;3
KC-08	Infected animals, dead or alive, will not be accepted for carriage.	2;6
KC-09	Dangerous goods consignments must be delivered early enough to allow sufficient time for the completion of the acceptance checks and document preparation. Shippers should contact the local cargo sales office to confirm the cut-off time.	
KC-10	Radioactive material, including all categories of excepted packages, are not accepted for carriage.	
KC-11	Dangerous goods in limited quantities ("Y" packing instructions) will not be accepted for carriage. (Exception: ID 8000 — Consumer commodity will be accepted.) (See 3;4 of these Instructions, 2.7 of the IATA Dangerous Goods Regulations and all "Y" packing instructions.)	3;4
+	KC-12 Dangerous goods in excepted quantities will not be accepted for carriage (see 2.6 of the IATA Dangerous Goods Regulations).	3;5
KE — KOREAN AIRLINES		
≠	<p>KE-01 Dangerous goods in consolidations (including excepted quantities and radioactive material in excepted packages) will not be accepted for carriage, except for the following shipments:</p> <ul style="list-style-type: none"> — consolidations having one master air waybill with one house air waybill; 	7;1

<i>Identifying code</i>	<i>Variation</i>	<i>Relevant paragraphs</i>
	— consolidations containing UN 1845 — Carbon dioxide, solid (dry ice) when used as a refrigerant.	
KE-02	Reservations must be made well in advance for any shipment containing dangerous goods as defined in these Instructions.	
KE-03	Shipper's declarations for dangerous goods must be completed in English, with copies requested by KE but not less than two copies for each shipment. All package and overpack markings required by these Instructions must also be completed in English.	5;2.5 5;4
KE-04	Not used.	
KE-05	Radioactive Type B(M) packages will not be accepted for carriage.	2;7 Table 3-1
KE-06	Dangerous goods, including "Dangerous goods in excepted quantity" and "Radioactive material in excepted package", will not be accepted for carriage on KE's passenger flights. The only exceptions are UN 3166, ID 8000, UN 1845, UN 2807 and UN 3373.	3;5
KE-07	Except for ID 8000 — Consumer commodity, all liquid dangerous goods must comply with the following packaging requirements in addition to those specified in the packing instructions: — Single packaging using UN specification packaging is: — acceptable if it is a steel drum (1A1 or 1A2) or composite packaging — plastic receptacle with outer steel drum (6HA1); — acceptable if it is overpacked by a strong wooden crate. — Combination packaging using limited quantity packaging is: — acceptable if it is overpacked by a strong wooden crate.	4;1 6;1
+	KK — ATLASJET AIRLINES	
KK-01	The shipper must provide a 24-hour emergency telephone number of a person/agency who is knowledgeable of the hazards, characteristics and actions to be taken in case of an accident or incident concerning each of the dangerous goods being transported. This telephone number, including the country and area code, preceded by the words "Emergency contact" or "24-hour number" must be shown on the shipper's declaration for dangerous goods (DGD) in the "Handling information" box and also on the package (see 8.1.6.11 and 10.8.3.11 of the IATA Dangerous Goods Regulations). A 24-hour emergency telephone number is not required for shipments that do not require a DGD.	5;4
KK-02	Dangerous goods in consolidations will not be accepted for carriage except for the following shipments: — consolidated shipments/consolidations containing carbon dioxide, solid (dry ice) when used as a refrigerant; — one master air waybill with one house air waybill; or — one master air waybill with more than one house air waybill from the same shipper and different consignees.	7;1
KK-03	Booking and confirmation are required for all dangerous goods shipments as defined in the IATA Dangerous Goods Regulations. Atlasjet Cargo Telephone: +90 212 663 20 00 Facsimile: +90 573 30 24 Email: cargo@atlasjet.com	

<i>Identifying code</i>	<i>Variation</i>	<i>Relevant paragraphs</i>	
KK-04	Material safety data sheet (MSDS) must be provided for dangerous goods except for dangerous goods in Class 7, vehicles, dangerous goods in apparatus or machinery and engines, ID 8000, magnetized material, carbon dioxide, solid (dry ice) and substances of Division 6.2. The MSDS must be written in English (see 8.0.1 and 8.3 of the IATA Dangerous Goods Regulations). The MSDS must include the UN number, proper shipping name and other relevant transport information.	5;4	
KK-05	Explosives will not be accepted for carriage, except substances and articles of Division 1.4S (see Packing Instructions 101–143).	2;1	
KK-06	Dangerous goods in excepted quantities will not be accepted for transport.	3;5	
KK-07	Class 8 — Corrosive material (Packing Groups I and II) will not be accepted for carriage. (See 800 series packing instructions).	2;8 Table 3-1 4;6	
KK-08	Class 7 — Radioactive material will not be accepted for carriage.	2;7 Table 3-1	
KK-09	The following items will not be accepted on Atlasjet Airlines flights: — UN 2803 — Gallium — UN 2809 — Mercury — UN 3506 — Mercury contained in manufactured articles	Table 3-1	
KK-10	Lithium metal batteries (UN 3090). Lithium metal cells and batteries are prohibited from carriage as cargo on Atlasjet aircraft. This prohibition applies to Section IA, Section IB and Section II of Packing Instruction 968. This prohibition does not apply to: — lithium metal cells and batteries packed with or contained in equipment (UN 3091) in accordance with Packing Instruction 969 or 970; — lithium ion cells and batteries (UN 3480 and UN 3481) in accordance with Packing Instruction 965, 966 or 967; or — lithium batteries (rechargeable and non-rechargeable) covered by the provisions for dangerous goods carried by passengers or crew. (See 2.3.2 to 2.3.5 and Table 2.3.A of the IATA Dangerous Goods Regulations and Part 8 of these Instructions.)	Table 3-1 4;11 8;1	
KK-11	All shipments of lithium batteries contained in equipment prepared in accordance with Section II of Packing Instruction 967 or 970 must include the mandatory wording on the air waybill as shown in Section II (“lithium ion batteries, in compliance with Section II of PI967” or “lithium metal batteries, in compliance with Section II of PI970”). This applies even to shipments where no lithium battery handling label is required to be affixed to the package(s).	4;11	
KK-12	Dangerous goods as defined in the IATA Dangerous Goods Regulations will not be accepted in airmail.	1;2;3	
KL — KLM, ROYAL DUTCH AIRLINES/KLM CITYHOPPER B.V.			
≠	KL-01	For Class 1 — Explosives, the shipper must obtain all authorizations required by the State(s) of origin, transit and destination. For transport and handling by KL, an approval must be obtained. Applications for an approval must be submitted via email to approval@klmcargo.com .	2;1 Table 3-1
	KL-02	Class 7 — Radioactive material, with the exception of UN 2908, UN 2909, UN 2910 and UN 2911, will not be accepted for transport and handling.	2;7 Table 3-1
≠	KL-03	Dangerous goods offered under State exemptions or approvals can be accepted pending approval from KL. Applications for an approval must be submitted by email to approval@klmcargo.com .	
+	KL-04	Division 2.3 — Toxic gases will not be accepted for transport and handling.	2;2

	<i>Identifying code</i>	<i>Variation</i>	<i>Relevant paragraphs</i>
+	KL-05	The shipper must provide a 24-hour emergency telephone number of a person/agency who is knowledgeable of the hazards, characteristics and actions to be taken in case of an accident or incident concerning each of the dangerous goods being transported. This telephone number, including the country and area code, preceded by wording indicating 24-hour availability must be shown on the shipper's declaration for dangerous goods (DGD).	5;4
KQ — KENYA AIRWAYS			
	KQ-01	Dangerous goods in consolidations will not be accepted for carriage except for: <ul style="list-style-type: none"> — ID 8000 — Consumer commodity; — UN 1845 — Carbon dioxide, solid or dry ice when used as a refrigerant for non-dangerous goods consignments. 	7;1
	KQ-02	Dangerous goods in excepted quantities will not be accepted for transport.	3;5
	KQ-03	Dangerous goods in airmail will not be accepted for transport.	1;2,3
	KQ-04	Dangerous goods shipments bearing toxic gas labels (Division 2.3) will not be accepted for carriage.	Table 3-1 5;3
	KQ-05	The shipper must provide a 24-hour emergency telephone number of a person that has knowledge of the hazards, characteristics and action to be taken in the event of an accident or incident concerning all dangerous goods being transported by air. The telephone number, which must include the country and area code, should be shown in the additional handling information box of the shipper's declaration for dangerous goods and on the package.	5;4
	KQ-06	Salvage packages will not be accepted for carriage.	4;1
	KQ-07	Interline transfer of dangerous goods will not be accepted unless a copy of the acceptance checklist accompanies the consignment together with the shipper's declaration for dangerous goods and the air waybill.	5;4 7;1
≠	KQ-08	Dangerous goods in limited quantities ("Y" packing instructions) will not be accepted for carriage except for dangerous goods in Class 9 and ID 8000 — Consumer commodities, as defined in the IATA Dangerous Goods Regulations and packed according to those regulations (see Special Provision A112).	3;3 3;4
+	KQ-09	UN 3091 — Lithium metal batteries and cells packed with or contained in equipment will only be transported on cargo aircraft.	Table 3-1 4;11
KZ — NIPPON CARGO AIRLINES			
	KZ-01	Advance arrangements must be made for all shipments of dangerous goods as defined in these Instructions. For magnetized materials (see Packing Instruction 953), the number of packages must be advised in advance. When an overpack is used, the number of packages inside the overpack must be advised.	4;11
	KZ-02	Any Type B package, Type C package, SCO or LSA materials in industrial packaging, packages containing uranium hexafluoride, and fissile material (including fissile-excepted) will not be accepted for all sectors.	2;7 Table 3-1 5;1
		However, the following radioactive material which does not contain fissile-excepted will be accepted with the prior approval of the government of Japan, authorities of States concerned and the Vice President and General Manager, Operations Management, Nippon Cargo Airlines.	
		UN 2916 — Radioactive material, Type B(U) package, non-fissile or fissile excepted.	
	KZ-03	For packagings containing liquid dangerous goods, sufficient ullage must be left in the packaging as described in 5.0.2.8 of the IATA Dangerous Goods Regulations.	4;1.1.5
	KZ-04	Not used.	

<i>Identifying code</i>	<i>Variation</i>	<i>Relevant paragraphs</i>
KZ-05	Dangerous goods in consolidations will not be accepted for carriage except for the following shipments: <ul style="list-style-type: none"> — consolidated shipments/consolidations containing carbon dioxide, solid (dry ice) when used as a refrigerant for non-dangerous goods; — one master air waybill with one house air waybill; or — one master air waybill with more than one house air waybills which have the same shipper and different consignees. 	7;1
KZ-06	Not used.	
≠ KZ-07	The following metal packagings without overpack are not acceptable for single packaging: <ul style="list-style-type: none"> — 1A1/1A2/1B1/1B2/1N1/1N2 — 3A1/3A2/3B1/3B2. <p>These packagings must be overpacked to protect the top and bottom of the packaging.</p>	6;1 5;1.1 e) 5;1.1 f) 5;2.4.10 5;3.3
KZ-08	Dangerous goods in salvage packagings will not be accepted for carriage.	4;1
KZ-09	The shipper must provide a 24-hour emergency telephone number of a person/agency who is knowledgeable of the hazards, characteristics and actions to be taken in case of an accident or incident concerning (each of) the dangerous goods being transported. This telephone number, including country and area code, preceded by the words "Emergency contact" or "24-hour number" must be inserted on the shipper's declaration for dangerous goods (DGD) preferably in the "Additional handling information" box, e.g. "Emergency contact +47 67 50 00 00". A 24-hour emergency telephone number is not required for shipments that do not require a DGD.	5;4
KZ-10	Dangerous Goods as defined in the IATA Dangerous Goods Regulations, including items exempted in subsection 2.4, will not be accepted in airmail.	1;2.3
KZ-11	For vehicles, machines or equipment with gasoline powered engines that have large capacity fuel tanks fitted, any remaining fuel must not exceed one quarter of the tank capacity, or 60 L, whichever is the lower quantity.	Table 3-1
LA — LAN AIRLINES		
+	LA Variations apply to LAN Airlines and its subsidiaries.	
≠ LA-01	Dangerous goods offered for transport under an approval or an exemption as provided by 1.2.5 and 1.2.6 of the IATA Dangerous Goods Regulations and any other LAN Airlines conditions by pre-approval will be accepted only after prior review and approval of the LATAM Dangerous Goods Technical Committee. In addition, UN 1040 and UN 2014, when shipped as excepted quantities in accordance with Special Provisions A131 and A75 respectively, also require prior review and approval of the LATAM Dangerous Goods Technical Committee. An application for approval must be undertaken at least fifteen working days in advance of the scheduled date for the flight. The material safety data sheet (MSDS) or other documentation that covers the shipment must be attached. Applications should be addressed to: LAN Airlines Dangerous Goods Department Telephone: +56-2-2694-7898 +56-2-677-4571/+56- 2-25669366 1-305-772-2894 Email: DangerousGoodsBoard@lan.com	1;1.1

Identifying code	Variation	Relevant paragraphs
LA-02	<p>The shipper must provide a 24-hour emergency telephone number of a person/agency who is knowledgeable of the hazards, characteristics and actions to be taken in case of an accident or incident concerning each of the dangerous goods being transported. This telephone number, including the country and area code, preceded by the words "Emergency contact" or "24-hour number" must be inserted on the declaration for dangerous goods in the "Handling Information" box. (See 8.1.6.11 and 10.8.3.11 of the IATA Dangerous Goods Regulations.)</p> <p>An emergency response telephone number is not required for:</p> <ul style="list-style-type: none"> — battery-powered equipment; — battery-powered vehicle; — flammable gas-powered vehicle; — flammable liquid-powered vehicle; — engine, internal combustion; — dangerous goods in limited quantities as described in 3;4 of these Instructions (2.7 of the IATA Dangerous Goods Regulations); — carbon dioxide, solid (dry ice); — consumer commodity; and — refrigerating machines. 	Table 3-1 5;4
LA-03	Not used.	
LA-04	Not used.	
LA-05	Not used.	
LA-06	<p>For toxic substances of Division 6.1 or Division 2.3, the following requirements must be complied with:</p> <ol style="list-style-type: none"> a) Toxic substances of Division 6.1, Packing Group I, that are toxic by inhalation, will not be accepted for carriage unless a prior approval has been obtained (see LA-01). b) Toxic gases of Division 2.3, will not be accepted for carriage unless a prior approval has been obtained (see LA-01) c) When the substance to be carried has an inhalation, mist, powder or vapour hazard, the shipper's declaration must have the following endorsement in the "Additional handling information" box: "Mist, powder or vapour inhalation hazard", as appropriate. <ul style="list-style-type: none"> <i>Note 1.— This requirement only applies to the primary risk.</i> <i>Note 2.— Where the substance has more than one route of toxicity, the risk that determined the packing group must be used.</i> d) Solid toxic substances of any kind will not be accepted for carriage in bags 5H1, 5H2, 5H3, 5H4, 5L2, 5L3, 5M1 or 5M2 as single packagings unless contained in a strong hot sealed polyethylene bag at least 200 microns thick. If these types of packages are offered overpacked in a warehouse pallet, they will be accepted for carriage provided: <ol style="list-style-type: none"> 1) the warehouse pallet is rigid and strong enough to support the weight assembled on it, without bending when picked up and transported by a forklift; 2) the surface of the warehouse pallet is continuous, soft and free of sharp protruding points which could pierce the bags; and 3) the warehouse pallet is provided with separation bars from the floor for the use of a forklift. 	2;3 2;6 5;4 6;1
LA-07	<p>Infectious substances will be accepted under specific advance arrangement and the following requirements must be met:</p> <ol style="list-style-type: none"> a) The shipper must prove by a document such as a fax, telex, letter, etc., that the infectious substance can legally enter the State of Destination and that all the requirements of the States of Origin and Destination of the shipment have been complied with. 	2;6 5;4

<i>Identifying code</i>	<i>Variation</i>	<i>Relevant paragraphs</i>
	<p>b) The shipper must attach a certificate duly signed and issued by a medical, scientific or other similar professional which confirms the classification of these specimens in the following cases:</p> <ul style="list-style-type: none"> — shipment of Biological substance, Category B; — shipment of any patient specimens prepared according to 3.6.2.2.3.6 of the IATA Dangerous Goods Regulations. <p>c) Infected animals, dead (whole bodies) or alive will not be accepted for carriage.</p>	
LA-08	Formaldehyde solutions containing less than 25% of formaldehyde must be shipped under UN 3334 — Aviation regulated liquid, n.o.s.*, Class 9, Packing Group III.	Table 3-1
≠ LA-09	<p>Unit load devices or freight containers containing dangerous goods described in 9.1.4, sub-paragraphs (a) to (d) of the IATA Dangerous Goods Regulations or lithium batteries prepared under Section II of Packing Instructions 965 to 970 will be accepted by advance arrangements and contract only in accordance with the current "Accreditation Freight Forwarder Programme" implemented by the LAN Airlines Dangerous Goods Department (see LA-01).</p> <p>The shipper/freight forwarder must deliver a document certifying that:</p> <ul style="list-style-type: none"> — the shipment was prepared on secure premises and protected against unlawful interference during preparation, storage and transport; and — packages comply with all requirements of the IATA Dangerous Goods Regulations. 	7;1.4
≠ LA-10	UN 3356 — Chemical oxygen generators transported to, from, through or within the United States must be placed in outer packaging that bears the additional tested specification mark of DOT 31FP indicating compliance with 49 CFR 173.168.	4;10
LA-11	Not used.	
LA-12	Not used.	
LA-13	Not used.	
LA-14	The marking required by 7.1.5 of the IATA Dangerous Goods Regulations and application of hazard and handling labels on packages containing dangerous goods must not be applied to the top or bottom of the packages. These markings and labels must be applied to the sides of packages. This requirement does not apply to marking of the full name and address of the shipper and consignee.	5;2 5;3
LA-15	Fissile material as defined in 10.3.7 of the IATA Dangerous Goods Regulations will be accepted only with prior review and approval by the LAN Dangerous Goods Technical Committee (see LA-01).	1;6.1.5 2;7
+ LA-16	<p>UN 3090 — Lithium metal batteries and UN 3091 — Lithium metal batteries contained in or packed with equipment. Primary (non-rechargeable) lithium (metal) batteries and cells must be transported on cargo aircraft only (CAO).</p> <p>This prohibition does not apply to:</p> <ul style="list-style-type: none"> — lithium batteries (rechargeable and non-rechargeable) covered by the provisions for dangerous goods carried by passengers or crew. (See Table 2.3.A of the IATA Dangerous Goods Regulations.) — lithium metal batteries and cells contained in medical equipment being transported for humanitarian reasons. — lithium metal batteries and cells that are presented as COMAT of any air company of LATAM Airlines Group. 	Table 3-1 4;11 8;1
LD — AIR HONG KONG		
LD-01	Not used.	
LD-02	All combination packagings containing liquid dangerous goods in Packing Group I, II or III must contain sufficient absorbent material to absorb the entire contents of all the inner packagings.	4;1
LD-03	Not used.	

<i>Identifying code</i>	<i>Variation</i>	<i>Relevant paragraphs</i>
LD-04	The shipper must provide a 24-hour emergency telephone number of a person/agency who is knowledgeable of the hazards, characteristics and actions to be taken in case of an accident or incident concerning (each of) the dangerous goods being transported. This telephone number, including the country and area code, preceded by the words "Emergency contact" or "24-hour number" must be inserted on the shipper's declaration for dangerous goods (DGD) preferably in the "Additional handling information" box, e.g. "Emergency contact +47 67 50 00 00". (See 8.1.6.11 and 10.8.3.11 of the IATA Dangerous Goods Regulations.)	5;4
LD-05	Liquid substances in single packagings of drums or jerricans of any material must be prepared as follows: <ol style="list-style-type: none"> 1) the steel drums/plastic drums/plastic jerricans must be protected by other strong outer packaging such as a fibreboard box; or 2) if prepared as an open overpack; a suitably-sized plastic, foam or wooden pallet must be used to protect at least the top and bottom of the packaging. 	2;8
LD-06	In addition to the requirements in 8.2.5 of the IATA Dangerous Goods Regulations, UN number(s) of all shipments of dangerous goods in excepted quantities must be indicated on the air waybill.	5;4
LD-07	Lithium metal batteries (UN 3090). Lithium metal cells and batteries are prohibited from carriage as cargo on Hong Kong aircraft. This prohibition applies to Section IA, Section IB and Section II of Packing Instruction 968. This prohibition does not apply to: <ul style="list-style-type: none"> — lithium metal cells and batteries packed with or contained in equipment (UN 3091) in accordance with Packing Instruction 969 or 970; — lithium ion cells and batteries (UN 3480 and UN 3481) in accordance with Packing Instruction 965, 966 or 967; or — lithium batteries (rechargeable and non-rechargeable) covered by the Provisions for Dangerous Goods Carried by Passengers or Crew. (See 2.3.2 to 2.3.5 and Table 2.3.A of the IATA Dangerous Goods Regulations and Part 8 of these Instructions.) 	Table 3-1 4;11 8;1
LD-08	All shipments of lithium batteries contained in equipment prepared in accordance with Section II of Packing Instruction 967 or 970 must include the mandatory wording on the air waybill as shown in Section II ("lithium ion batteries, in compliance with Section II of PI967" or "lithium metal batteries, in compliance with Section II of PI970"). This applies even to shipments where no lithium battery handling label is required to be affixed to the package(s).	4;11
LG — LUXAIR		
LG-01	Class 7 — Fissile radioactive material will not be accepted for carriage on passenger aircraft.	2;7 Table 3-1
LG-02	Radioactive material is accepted for carriage on passenger aircraft with a maximum transport index (TI) of two per aircraft. (See 9.3.10.3 and 10.5.15 of the IATA Dangerous Goods Regulations.) Radioactive material is forbidden on Embraer and DHC8-400 aircraft with the exception of UN 2908, UN 2910 and UN 2911 (Radioactive material, excepted packages).	2;7 Table 3-1 5;1 7;2
LH — DEUTSCHE LUFTHANSA/LUFTHANSA CARGO AG		
LH-01	Dangerous goods in "limited quantities" ("Y" packing instructions) will not be accepted for carriage. Exception: ID 8000 — Consumer commodity will be accepted. (See 3;4 of these Instructions, 2.7 of the IATA Dangerous Goods Regulations and all "Y" packing instructions.)	3;4
LH-02	Dangerous goods in consolidations will not be accepted for carriage, except for the following shipments: <ul style="list-style-type: none"> — consolidations containing UN 1845, Carbon dioxide, solid (dry ice) when used as a refrigerant; — consolidations with only one house air waybill; 	7;1

<i>Identifying code</i>	<i>Variation</i>	<i>Relevant paragraphs</i>
	— consolidations with more than one house air waybill, in case of identical shipper.	
LH-03	Biological substance, Category B (UN 3373) will not be accepted in airmail.	1;2.3
LH-04	Oxygen generators will not be accepted.	Table 3-1
LH-05	Biological substance, Category B (UN 3373), will not be accepted as cargo.	Table 3-1
LH-06	Fissile material will not be accepted.	Table 3-1
LH-07	Intermediate bulk containers (IBC) will not be accepted. Exception: The IBC packagings 11A, 21A, 11B, 21B, 11N, 21N and 11C will be accepted under the condition that they are stackable with a minimum top-load of 2 000 kg (stacking test load at least 3 600 kg). Advance arrangements with Lufthansa Cargo AG are required.	
LP — LAN PERU		
≠	<p>LP-01 Dangerous goods offered for transport under an approval or an exemption as provided by 1.2.5 and 1.2.6 of the IATA Dangerous Goods Regulations and any other LAN Perú conditions by pre-approval will be accepted only after prior review and approval of the LATAM Dangerous Goods Technical Committee.</p> <p>In addition, UN 1040 and UN 2014, when shipped as excepted quantities in accordance with Special Provisions A131 and A75 respectively, also require prior review and approval of the LATAM Dangerous Goods Technical Committee.</p> <p>An application for approval must be undertaken at least fifteen working days in advance of the scheduled date for the flight. The material safety data sheet (MSDS) or other documentation that covers the shipment must be attached. Applications should be addressed to:</p> <p>LAN Peru Dangerous Goods Department Telephone: +511-207 8440, Ext. 73135 +56-2-2677-4571/+56-2-25669366 +1-305-772-2894 Email: DangerousGoodsBoard@lan.com</p>	1;1.1
	<p>LP-02 The shipper must provide a 24-hour emergency telephone number of a person/agency who is knowledgeable of the hazards, characteristics and actions to be taken in case of an accident or incident concerning each of the dangerous goods being transported. This telephone number, including the country and area code, preceded by the words "Emergency contact" or "24-hour number" must be inserted on the declaration for dangerous goods in the "Handling Information" box. (See 8.1.6.11 and 10.8.3.11 of the IATA Dangerous Goods Regulations.)</p> <p>An emergency response telephone number is not required for:</p> <ul style="list-style-type: none"> — battery-powered equipment; — battery-powered vehicle; — flammable gas-powered vehicle; — flammable liquid-powered vehicle; — engine, internal combustion; — dangerous goods in limited quantities as described in 3;4 of these Instructions (2.7 of the IATA Dangerous Goods Regulations); — carbon dioxide, solid (dry ice); — consumer commodity; and — refrigerating machines. 	Table 3-1 5;4

<i>Identifying code</i>	<i>Variation</i>	<i>Relevant paragraphs</i>
LP-03	<p>For toxic substances of Division 6.1 or Division 2.3, the following requirements must be complied with:</p> <p>a) Toxic substances of Division 6.1, Packing Group I, that are toxic by inhalation, will not be accepted for carriage unless a prior approval has been obtained (see LA-01).</p> <p>b) Toxic gases of Division 2.3 will not be accepted for carriage unless a prior approval has been obtained (see LA-01).</p> <p>c) When the substance to be carried has an inhalation, mist, powder or vapour hazard, the shipper's declaration must have the following endorsement in the "Additional handling information box": "Mist, powder or vapour inhalation hazard", as appropriate.</p> <p><i>Note 1.— This requirement only applies to the primary risk.</i></p> <p><i>Note 2.— Where the substance has more than one route of toxicity, the risk that determined the packing group must be used.</i></p> <p>d) Solid toxic substances of any kind will not be accepted for carriage in bags 5H1, 5H2, 5H3, 5H4, 5L2, 5L3, 5M1 or 5M2 as single packagings unless contained in a strong hot sealed polyethylene bag at least 200 microns thick. If these types of packages are offered overpacked in a warehouse pallet, they will be accepted for carriage provided:</p> <ol style="list-style-type: none"> 1) the warehouse pallet is rigid and strong enough to support the weight assembled on it, without bending when picked up and transported by a forklift; 2) the surface of the warehouse pallet is continuous, soft and free of sharp protruding points which could pierce the bags; and 3) the warehouse pallet is provided with separation bars from the floor for the use of a forklift. 	<p>2;3 2;6 5;4 6;1</p>
LP-04	<p>Infectious substances will be accepted under specific advance arrangements and the following requirements must be met:</p> <p>a) The shipper must prove by a document such as a fax, telex, letter, etc., that the infectious substance can legally enter the State of Destination and that all the requirements of the States of Origin and Destination of the shipment have been complied with.</p> <p>b) The shipper must attach a certificate duly signed and issued by a medical, scientific or other similar professional which confirms the classification of these specimens in the following cases:</p> <ul style="list-style-type: none"> — shipment of Biological substance, Category B; — shipment of any patient specimens prepared according to 3.6.2.2.3.6 of the IATA Dangerous Goods Regulations. <p>c) Infected animals, dead (whole bodies) or alive will not be accepted for carriage.</p>	<p>2;6.3.2.3.6 5;4</p>
LP-05	<p>Formaldehyde solutions containing less than 25% of formaldehyde must be shipped under UN 3334 — Aviation regulated liquid, n.o.s.*, Class 9, Packing Group III.</p>	<p>Table 3-1</p>
LP-06	<p>The marking required by 7.1.5 of the IATA Dangerous Goods Regulations and application of hazard and handling labels on packages containing dangerous goods must not be applied to the top or bottom of packages. These markings and labels must be applied to the sides of packages. This requirement does not apply to marking of the full name and address of the shipper and consignee.</p>	<p>5;2 5;3</p>
LP-07	<p>Fissile material as defined in 10.3.7 of the IATA Dangerous Goods Regulations will be accepted only with prior review and approval by the LAN Dangerous Goods Technical Committee (see LA-01).</p>	<p>1;6.1.5 2;7</p>

<i>Identifying code</i>	<i>Variation</i>	<i>Relevant paragraphs</i>
+	<p>LP-08 UN 3090 — Lithium metal batteries and UN 3091 — Lithium metal batteries contained in or packed with equipment. Primary (non-rechargeable) lithium (metal) batteries and cells must be transported on cargo aircraft only (CAO).</p> <p>This prohibition does not apply to:</p> <ul style="list-style-type: none"> — lithium batteries (rechargeable and non-rechargeable) covered by the provisions for dangerous goods carried by passengers or crew. (See Table 2.3.A of the IATA Dangerous Goods Regulations.) — lithium metal batteries and cells contained in medical equipment being transported for humanitarian reasons. — lithium metal batteries and cells that are presented as COMAT of any air company of LATAM Airlines Group. 	Table 3-1 4;11 8;1
+	<p>LP-09 Unit load devices or freight containers containing dangerous goods described in 9.1.4, sub-paragraphs (a) to (d) of the IATA Dangerous Goods Regulations or lithium batteries prepared under Section II of Packing Instructions 965 to 970 will be accepted by advance arrangements and contract only in accordance with the current "Accreditation Freight Forwarder Programme" implemented by the LAN Peru Dangerous Goods Department (see LP-01).</p> <p>The shipper/freight forwarder must deliver a document certifying that:</p> <ul style="list-style-type: none"> — the shipment was prepared on secure premises and protected against unlawful interference during preparation, storage and transport; and — packages comply with all requirements of the IATA Dangerous Goods Regulations. 	7;1.4
+	<p>LP-10 UN 3356 — Chemical oxygen generators transported to, from, through or within the United States must be placed in outer packaging that bears the additional tested specification mark of DOT 31FP indicating compliance with 49 CFR 173.168.</p>	4;7
+	<p>LR — LACSA</p>	
	<p>LR-01 Wheelchairs with spillable or wet batteries will be accepted only when the battery has been removed from the wheelchair and packaged according to paragraphs 2.3.2.3 and 9.3.14 of the IATA Dangerous Goods Regulations.</p>	8;1
	<p>LR-02 Oxygen, compressed, UN 1072 for medical use during flight, will not be accepted for carriage.</p>	8;1
	<p>LR-03 Dangerous goods in airmail will not be accepted for carriage.</p>	1;2.3
	<p>LR-04 Fissile radioactive material will not be accepted for carriage. (See 10.5.13 of the IATA Dangerous Goods Regulations.)</p>	2;7
	<p>LR-05 Radioactive material will only be accepted for transport when the radioactive material is intended for diagnostic purposes, medical treatment, industrial or research.</p>	2;7 5;1
	<p>LR-06 Mercury — UN 2809 will be accepted for transport provided the following conditions are complied with:</p> <ul style="list-style-type: none"> — only combination packagings will be accepted; — outer packagings must have a strong inner lining or leak-proof bags, puncture-resistant material, impervious to mercury; and — must be overpacked with a plastic box. 	Table 3-1 4;1
	<p>LR-07 Arrangement with the airline is necessary for packages that contain dry ice.</p>	Table 3-1 4;11 5;1 7;2
	<p>LR-08 Spanish must be used in addition to English for all markings and dangerous goods documentation for domestic and international transport from Costa Rica.</p>	5;2 5;3 5;4

LU — LAN EXPRESS

≠ LU-01 Dangerous goods offered for transport under an approval or an exemption as provided by 1.2.5 and 1.2.6 of the IATA Dangerous Goods Regulations and any other LAN Express conditions by pre-approval will be accepted only after prior review and approval of the LATAM Dangerous Goods Technical Committee. 1;1.1

In addition, UN 1040 and UN 2014, when shipped as excepted quantities in accordance with Special Provisions A131 and A75 respectively, also require prior review and approval of the LATAM Dangerous Goods Technical Committee.

An application for approval must be undertaken at least fifteen working days in advance of the scheduled date for the flight. The material safety data sheet (MSDS) or other documentation that covers the shipment must be attached. Applications should be addressed to:

LAN Express Dangerous Goods Department
 Telephone: +56-2-2694-7898
 +56-2-677-4571 /+56-2-25669366
 +1-305-772-2894
 Email: DangerousGoodsBoard@lan.com

LU-02 The shipper must provide a 24-hour emergency telephone number of a person/agency who is knowledgeable of the hazards, characteristics and actions to be taken in case of an accident or incident concerning each of the dangerous goods being transported. This telephone number, including the country and area code, preceded by the words "Emergency contact" or "24-hour number" must be inserted on the declaration for dangerous goods in the "Handling Information" box. (See 8.1.6.11 and 10.8.3.11 of the IATA Dangerous Goods Regulations.) Table 3-1
5;4

An emergency response telephone number is not required for:

- battery-powered equipment;
- battery-powered vehicle;
- flammable gas-powered vehicle;
- flammable liquid-powered vehicle;
- engine, internal combustion;
- dangerous goods in limited quantities as described in 3;4 of these Instructions (2.7 of the IATA Dangerous Goods Regulations);
- carbon dioxide, solid (dry ice);
- consumer commodity; and
- refrigerating machines.

LU-03 For toxic substances of Division 6.1 or Division 2.3, the following requirements must be complied with: 2;3
2;6
5;4
6;1

- a) Toxic substances of Division 6.1, Packing Group I, that are toxic by inhalation, will not be accepted for carriage unless a prior approval has been obtained (see LA-01).
- b) Toxic gases of Division 2.3 will not be accepted for carriage unless a prior approval has been obtained (see LA-01).
- c) When the substance to be carried has an inhalation, mist, powder or vapour hazard, the shipper's declaration must have the following endorsement in the "Additional handling information box": "Mist, powder or vapour inhalation hazard", as appropriate.

Note 1.— This requirement only applies to the primary risk.

Note 2.— Where the substance has more than one route of toxicity, the risk that determined the packing group must be used.

	<p>d) Solid toxic substances of any kind will not be accepted for carriage in bags 5H1, 5H2, 5H3, 5H4, 5L2, 5L3, 5M1 or 5M2 as single packagings unless contained in a strong hot sealed polyethylene bag at least 200 microns thick. If these types of packages are offered overpacked in a warehouse pallet, they will be accepted for carriage provided:</p> <ol style="list-style-type: none"> 1) the warehouse pallet is rigid and strong enough to support the weight assembled on it, without bending when picked up and transported by a forklift; 2) the surface of the warehouse pallet is continuous, soft and free of sharp protruding points which could pierce the bags; and 3) the warehouse pallet is provided with separation bars from the floor for the use of a forklift. 	
LU-04	<p>Infectious substances will be accepted under specific advance arrangements and the following requirements must be met:</p> <ol style="list-style-type: none"> a) The shipper must prove by a document such as a fax, telex, letter, etc., that the infectious substance can legally enter the State of Destination and that all the requirements of the States of Origin and Destination of the shipment have been complied with. b) The shipper must attach a certificate duly signed and issued by a medical, scientific or other similar professional which confirms the classification of these specimens in the following cases: <ul style="list-style-type: none"> — shipment of Biological substance, Category B; — shipment of any patient specimens prepared according to 3.6.2.2.3.6 of the IATA Dangerous Goods Regulations. c) Infected animals, dead (whole bodies) or alive will not be accepted for carriage. 	2;6.3.2.3.6 5;4
LU-05	Formaldehyde solutions containing less than 25% of formaldehyde must be shipped under UN 3334 — Aviation regulated liquid, n.o.s.*, Class 9, Packing Group III.	Table 3-1
LU-06	The marking required by 7.1.5 of the IATA Dangerous Goods Regulations and application of hazard and handling labels on packages containing dangerous goods must not be applied to the top or bottom of packages. These markings and labels must be applied to the sides of packages. This requirement does not apply to marking of the full name and address of the shipper and consignee.	5;2 5;3
LU-07	Fissile material as defined in 10.3.7 of the IATA Dangerous Goods Regulations will be accepted only with prior review and approval by the IATA Dangerous Goods Technical Committee (see LA-01).	1;6.1.5 2;7
+ LU-08	<p>UN 3090 — Lithium metal batteries and UN 3091 — Lithium metal batteries contained in or packed with equipment. Primary (non-rechargeable) lithium (metal) batteries and cells must be transported on cargo aircraft only (CAO).</p> <p>This prohibition does not apply to:</p> <ul style="list-style-type: none"> — lithium batteries (rechargeable and non-rechargeable) covered by the provisions for dangerous goods carried by passengers or crew. (See Table 2.3.A of the IATA Dangerous Goods Regulations.); — lithium metal batteries and cells contained in medical equipment being transported for humanitarian reasons; — lithium metal batteries and cells that are presented as COMAT of any air company of LATAM Airlines Group. 	Table 3-1 4;11 8;1

- + LU-09 Unit load devices or freight containers containing dangerous goods described in 9.1.4, sub-paragraphs (a) to (d) of the IATA Dangerous Goods Regulations or lithium batteries prepared under Section II of Packing Instructions 965 to 970 will be accepted by advance arrangements and contract only in accordance with the current "Accreditation Freight Forwarder Programme" implemented by the LAN Express Dangerous Goods Department (see LU-01). 7;1.4

The shipper/freight forwarder must deliver a document certifying that:

- the shipment was prepared on secure premises and protected against unlawful interference during preparation, storage and transport; and
- packages comply with all requirements of the IATA Dangerous Goods Regulations.

- + LU-10 UN 3356 — Chemical oxygen generators transported to, from, through or within the United States must be placed in outer packaging that bears the additional tested specification mark of DOT 31FP indicating compliance with 49 CFR 173.168. 4;7

LX — SWISS INTERNATIONAL

- LX-01 The following Class 7 articles or substances will not be accepted for carriage: 2;7
Table 3-1
- UN 2919 — Radioactive material, transported under special arrangement), non-fissile or fissile excepted
 - UN 2977 — Radioactive material, uranium hexafluoride, fissile
 - UN 3321 — Radioactive material, low specific activity (LSA-II), non-fissile or fissile excepted
 - UN 3322 — Radioactive material, low specific activity (LSA-III), non-fissile or fissile excepted
 - UN 3324 — Radioactive material, low specific activity (LSA-II), fissile
 - UN 3325 — Radioactive material, low specific activity (LSA-III), fissile
 - UN 3326 — Radioactive material, surface contaminated objects (SCO-I or SCO-II), fissile
 - UN 3327 — Radioactive material, Type A package, fissile
 - UN 3328 — Radioactive material, Type B(U) package, fissile
 - UN 3329 — Radioactive material, Type B(M) package, fissile
 - UN 3330 — Radioactive material, Type C package, fissile
 - UN 3331 — Radioactive material, transported under special arrangement, fissile
 - UN 3333 — Radioactive material, Type A package, special form, fissile.
- LX-02 Except for ID 8000 — Consumer commodity, dangerous goods in limited quantities ("Y" packing instructions) will not be accepted for carriage. (See 3;4 of these Instructions, 2.7 of the IATA Dangerous Goods Regulations and all "Y" packing instructions.) 3;4
- LX-03 Mercurial barometers or thermometers will not be accepted for carriage in baggage, except a small medical or clinical thermometer for personal use when in its protective case. 8;1
- LX-04 Camping stoves (fuel or gas) will not be accepted for carriage in baggage. This variation applies also to used camping stoves which have been thoroughly cleaned. 8;1
- LX-05 The shipper must provide a 24-hour emergency telephone number of a person who is knowledgeable of the hazards, characteristics and actions to be taken in the case of an accident or incident. The telephone number must include the country and area code and preceded by the words "Emergency contact" or "24-hour number" and must be inserted on the shipper's declaration for dangerous goods, preferably in the "Handling information" box. 5;4
- A 24-hour emergency telephone number is not required for shipments that do not require a shipper's declaration for dangerous goods.

+	LX-06	<p>The following items must not be accepted for carriage on Swiss International:</p> <ul style="list-style-type: none"> — UN 3090 — Lithium metal batteries in accordance with Section IA of Packing Instruction 968; — UN 3090 — Lithium metal batteries in accordance with Section IB of Packing Instruction 968; — UN 3091 — Lithium metal batteries packed with equipment in accordance with Section I of Packing Instruction 969; — UN 3091 — Lithium metal batteries contained in equipment in accordance with Section I of Packing Instruction 970; and — UN 3480 — Lithium ion batteries in accordance with Section IA of Packing Instruction 965. <p>For UN 3480 — Lithium ion batteries in accordance with Section IB of Packing Instruction 965, an approval by LX Headquarters is required. For more information, please contact your local LX cargo office.</p>	8;1
LY — EL AL ISRAEL AIRLINES			
	LY-01	<p>No dangerous goods will be accepted as part of a consolidated air waybill and the following endorsement is required in the “Nature and quantity of goods” box: “Consolidation — shipment does not contain dangerous goods”.</p>	5;4
	LY-02	Not used.	
	LY-03	Not used.	
	LY-04	<p>Dangerous goods not acceptable on El Al passenger aircraft:</p> <p>Class 1 — Explosives Except: Those explosives in Division 1.4S permitted by the IATA Dangerous Goods Regulations.</p> <p>Class 2 Division 2.1 — Flammable gas Division 2.2 — Non-flammable, non-toxic gas Division 2.3 — Toxic gas Except: — Fire extinguishers, UN 1044;</p> <p>— Oxygen compressed, UN 1072, Division 2.2 with subsidiary risk Division 5.1, as spare parts prior/after use of oxygen supply for passengers requiring medical attention may be carried on passenger aircraft provided the article is packed in specially designed containers, part no. 24303 and part no. 9353103;</p> <p>— Compressed gas, n.o.s. — UN 1956.</p> <p>Class 3 — Flammable liquids Except: Perfumery products, UN 1266, packed according to Packing Instruction 353, Packing Group II or packed according to Packing Instruction 355, Packing Group III. May be carried on Boeing 747, Boeing 767 and Boeing 777 passenger aircraft, provided the products are palletized in a maximum of two pallets per aircraft (only one pallet per compartment).</p> <p>Class 4 Division 4.1 — Flammable solids Division 4.2 — Spontaneously combustible Division 4.3 — Dangerous when wet</p> <p>Class 5 Division 5.1 — Oxidizing substances Division 5.2 — Organic peroxides</p>	Table 3-1 7;1, 7;2

Class 6

Division 6.1 — Toxic substances, Packing Group I and/or II

Except:

- 1) Medicine, liquid, toxic, n.o.s.,* UN 1851.
- 2) Medicine, solid, toxic, n.o.s.,* UN 3249.
- 3) Toxic substances, without a subsidiary risk, Packing Group III.

Division 6.2 — Infectious substances

Except:

- 1) Infectious substance, affecting animals, UN 2900
- 2) Infectious substance, affecting humans, UN 2814
- 3) Biological substance, Category B — UN 3373

Class 9 — Miscellaneous dangerous goods

Except:

- 1) Life-saving appliances, self-inflating, UN 2990 and Air bag inflators, Air bag modules or Seat-belt pretensioners, UN 3268.
- 2) Consumer commodity, ID 8000, Packing Instruction Y963, prepared according to the IATA Dangerous Goods Regulations.
- 3) Battery-powered vehicle or Battery-powered equipment, UN 3171 or Engines, internal combustion, Vehicle flammable gas powered or Vehicle flammable liquid powered, UN 3166, may be carried on passenger aircraft, provided the standard precautions for carriage include defuelling so that the fuel and/or diesel engines have no more than one quarter tank of fuel.
- 4) Shipments of crated self-propelled vehicles and equipment such as cars, motorcycles and lawnmowers must be carried as per the following regulations:
 - loading in an upright position;
 - retaining up to one quarter tank of gasoline or diesel.
- 5) Engine internal combustion, UN 3166 — jet engines must be totally defuelled and the air waybill must show the following mandatory shipper statement:

“We hereby declare that the engines have been defuelled completely and no evidence of leakage of fuel and oil are shown.”

Note.— Shippers wishing to ship crated items mentioned above must be advised of EI AI requirements and be requested to state on the air waybill that “EI AI regulations have been complied with.”
- 6) Magnetized material, UN 2807.
- 7) Carbon dioxide, solid (dry ice), UN 1845, not more than 200 kg per hold and not more than 400 kg in the lower deck.
- 8) Lithium metal batteries, UN 3090, Lithium metal batteries contained in equipment, UN 3091, Lithium metal batteries packed with equipment, UN 3091, Lithium ion batteries, UN 3480, Lithium ion batteries contained in equipment, UN 3481, Lithium ion batteries packed with equipment, UN 3481:
 - Fully regulated lithium ion batteries as per Section I of Packing Instructions 965-967;
 - Fully regulated lithium metal batteries as per Section I of Packing Instructions 968-970.
- 9) Environmentally hazardous substance, liquid, n.o.s.*, UN 3082 and Environmentally hazardous substance, solid, n.o.s.*, UN 3077

LY-05 Dangerous goods not acceptable on EI AI cargo aircraft:

Table 3-1

Class 2, Division 2.3 — Toxic gas.

Class 6, Division 6.1 — Toxic substances, liquids having a vapour inhalation toxicity of Packing Group I.

Class 9: Carbon dioxide, solid (Dry ice), UN 1845

- No more than 200 kg per hold, and no more than a total of 400 kg in the lower decks.

— No more than 3 000 kg in cargo aircraft main deck.

Note.— *Livestock must not be loaded in the vicinity of dry ice.*

L7 — LANCO

≠ L7-01 Dangerous goods offered for transport under an approval or an exemption as provided by 1.2.5 and 1.2.6 of the IATA Dangerous Goods Regulations and any other LANCO conditions by pre-approval will be accepted only after prior review and approval of the LATAM Dangerous Goods Technical Committee. 1;1.1

In addition, UN 1040 and UN 2014, when shipped as excepted quantities in accordance with Special Provisions A131 and A75 respectively, also require prior review and approval of the LATAM Dangerous Goods Technical Committee.

An application for approval must be undertaken at least fifteen working days in advance of the scheduled date for the flight. The material safety data sheet (MSDS) or other documentation that covers the shipment must be attached. Applications should be addressed to:

LANCO Dangerous Goods Department
 Telephone: +57-1-4259600, Ext. 71312
 +56-2-26774571/+56-2-25669366
 +1 305-7722894
 Email: DangerousGoodsBoard@lan.com

L7-02 The shipper must provide a 24-hour emergency telephone number of a person/agency who is knowledgeable of the hazards, characteristics and actions to be taken in case of an accident or incident concerning each of the dangerous goods being transported. This telephone number, including the country and area code, preceded by the words "Emergency contact" or "24-hour number" must be inserted on the declaration for dangerous goods in the "Handling Information" box. (See 8.1.6.11 and 10.8.3.11 of the IATA Dangerous Goods Regulations.) Table 3-1
5;4

An emergency response telephone number is not required for:

- battery-powered equipment;
- battery-powered vehicle;
- flammable gas-powered vehicle;
- flammable liquid-powered vehicle;
- engine, internal combustion;
- dangerous goods in limited quantities as described in 3;4 of these Instructions (2.7 of the IATA Dangerous Goods Regulations);
- carbon dioxide, solid (dry ice);
- consumer commodity; and
- refrigerating machines.

L7-03 For toxic substances of Division 6.1 or Division 2.3, the following requirements must be complied with: 2;3
2;6
5;4
6;1

a) Toxic substances of Division 6.1, Packing Group I, that are toxic by inhalation, will not be accepted for carriage unless a prior approval has been obtained (see LA-01).

b) Toxic gases of Division 2.3 will not be accepted for carriage unless a prior approval has been obtained (see LA-01).

c) When the substance to be carried has an inhalation, mist, powder or vapour hazard, the shipper's declaration must have the following endorsement in the "Additional handling information box": "Mist, powder or vapour inhalation hazard", as appropriate.

Note 1.— *This requirement only applies to the primary risk.*

Note 2.— *Where the substance has more than one route of toxicity, the risk that determined the packing group must be used.*

	d) Solid toxic substances of any kind will not be accepted for carriage in bags 5H1, 5H2, 5H3, 5H4, 5L2, 5L3, 5M1 or 5M2 as single packagings unless contained in a strong hot sealed polyethylene bag at least 200 microns thick. If these types of packages are offered overpacked in a warehouse pallet, they will be accepted for carriage provided:	
	1) the warehouse pallet is rigid and strong enough to support the weight assembled on it, without bending when picked up and transported by a forklift;	
	2) the surface of the warehouse pallet is continuous, soft and free of sharp protruding points which could pierce the bags; and	
	3) the warehouse pallet is provided with separation bars from the floor for the use of a forklift.	
L7-04	Infectious substances will be accepted under specific advance arrangements and the following requirements must be met:	2;6.3.2.3.6 5;4
	a) The shipper must prove by a document such as a fax, telex, letter, etc., that the infectious substance can legally enter the State of Destination and that all the requirements of the States of Origin and Destination of the shipment have been complied with.	
	b) The shipper must attach a certificate duly signed and issued by a medical, scientific or other similar professional which confirms the classification of these specimens in the following cases:	
	— shipment of Biological substance, Category B;	
	— shipment of any patient specimens prepared according to 3.6.2.2.3.6 of the IATA Dangerous Goods Regulations.	
	c) Infected animals, dead (whole bodies) or alive will not be accepted for carriage.	
L7-05	Formaldehyde solutions containing less than 25% of formaldehyde must be shipped under UN 3334 — Aviation regulated liquid, n.o.s.*, Class 9, Packing Group III.	Table 3-1
L7-06	The marking required by 7.1.5 of the IATA Dangerous Goods Regulations and application of hazard and handling labels on packages containing dangerous goods must not be applied to the top or bottom of packages. These markings and labels must be applied to the sides of packages. This requirement does not apply to marking of the full name and address of the shipper and consignee.	5;2 5;3
L7-07	Fissile material as defined in 10.3.7 of the IATA Dangerous Goods Regulations will be accepted only with prior review and approval by the LAN Dangerous Goods Technical Committee (see LA-01).	1;6.1.5 2;7
+	L7-08 UN 3090 — Lithium metal batteries and UN 3091 — Lithium metal batteries contained in or packed with equipment. Primary (non-rechargeable) lithium (metal) batteries and cells must be transported on cargo aircraft only (CAO). This prohibition does not apply to:	Table 3-1 4;11 8;1
	— lithium batteries (rechargeable and non-rechargeable) covered by the provisions for dangerous goods carried by passengers or crew. (See Table 2.3.A of the IATA Dangerous Goods Regulations.);	
	— lithium metal batteries and cells contained in medical equipment being transported for humanitarian reasons;	
	— lithium metal batteries and cells that are presented as COMAT of any air company of LATAM Airlines Group.	

- | | | | |
|---|-------|---|-------|
| + | L7-09 | Unit load devices or freight containers containing dangerous goods described in 9.1.4, sub-paragraphs (a) to (d) of the IATA Dangerous Goods Regulations or lithium batteries prepared under Section II of Packing Instructions 965 to 970 will be accepted by advance arrangements and contract only in accordance with the current "Accreditation Freight Forwarder Programme" implemented by the LANCO Dangerous Goods Department (see L7-01). | 7;1.4 |
| | | The shipper/freight forwarder must deliver a document certifying that: | |
| | | — the shipment was prepared on secure premises and protected against unlawful interference during preparation, storage and transport; and | |
| | | — packages comply with all requirements of the IATA Dangerous Goods Regulations. | |
| + | L7-10 | UN 3356 — Chemical oxygen generators transported to, from, through or within the United States must be placed in outer packaging that bears the additional tested specification mark of DOT 31FP indicating compliance with 49 CFR 173.168. | 4;7 |

MD — AIR MADAGASCAR

- | | | |
|-------|--|------------------|
| MD-01 | Fissile material, as defined in the IATA Dangerous Goods Regulations, will not be accepted for carriage. | 2;7
Table 3-1 |
| MD-02 | Radioactive material of categories I-White, II-Yellow and III-Yellow will be accepted on board Air Madagascar long-haul flights provided the following conditions are complied with: | Table 3-1
5;1 |
| | a) the radioactive material must be used in analysis for medical purposes with direct relation to human health or for medical diagnostic and medical research; | |
| | b) the total transport index (TI) in a group of packages or in one package must not exceed 3.0; | |
| | c) prior approval of the Civil Aviation Authority and Air Madagascar Regulation Department has been obtained. | |
| MD-03 | Class 7 — Radioactive materials of any kind will not be accepted for carriage on Air Madagascar domestic flights. | 2;7
Table 3-1 |
| MD-04 | Class 1 — Explosives. Shippers must obtain prior approval from the Civil Aviation Authority and the Air Madagascar regulation department for all explosives transported to and through Madagascar. The request must be submitted at least five working days prior to shipment. | 2;1 |
| MD-05 | Fireworks will not be accepted for carriage. | Table 3-1 |

ME — MIDDLE EAST AIRLINES

- | | | |
|-------|--|------|
| ME-01 | Dangerous goods in excepted quantities will not be accepted for carriage. | 3;5 |
| ME-02 | Dangerous goods in consolidations will not be accepted for carriage. | 7;1 |
| ME-03 | Advance arrangements must be made for all shipments containing dangerous goods as defined in these Instructions. | |
| ME-04 | Cars and crated self-propelled vehicles or battery-powered equipment or other machines incorporating internal combustion engines may be carried provided the standard precautions include the following: | 4;11 |
| | — complete defuelling, except cars, which may retain up to one quarter of the tank capacity; | |
| | — disconnecting the battery leads; | |
| | — insulating the battery terminals. | |
| ME-05 | Dangerous goods in salvage packaging will not be accepted for carriage. | 4;1 |
| ME-06 | Hazardous waste, as defined by any regulation of the IATA Dangerous Goods Regulations, will not be accepted for carriage. | |

ME-07	<p>Oxygen generator, chemical, UN 3356, Oxidizing solid, n.o.s.*, UN 1479, Flammable solid, organic, n.o.s.*, UN 1325 or any oxygen generator containing any of the following substances will not be accepted for carriage (see packing instructions [-] listed after each substance):</p> <p style="margin-left: 20px;">UN 1449 — Barium peroxide [558, 562, Y543] UN 1489 — Potassium perchlorate [558, 562, Y544] UN 1491 — Potassium peroxide [561] UN 1495 — Sodium chlorate [558, 562, Y544] UN 1504 — Sodium peroxide [561] UN 2466 — Potassium superoxide [561] UN 2547 — Sodium superoxide [561].</p> <p>Also carriage of oxygen generators containing substances such as iron powder, iron dust, silicon dioxide and manganese dioxide which do not have specific proper shipping names are prohibited.</p>	Table 3-1 4;7
ME-08	Not used.	
ME-09	Package orientation (This Way Up) labels must be used on any combination and single packaging containing dangerous goods.	5;3
MH — MALAYSIA AIRLINES		
MH-01	<p>Advance arrangements must be made for all shipments of dangerous goods as defined in the IATA Dangerous Goods Regulations. Dangerous goods without bookings will be rejected.</p> <p><i>Note.— All dangerous goods in liquid form when transported on narrow-body aircraft, e.g. B737, must be packed in combination packagings. Single packagings are not permitted.</i></p>	
MH-02	Dangerous goods including infectious substances, biological products and radioactive material are not accepted for carriage in mail.	1;2,3
MH-03	Salvage packaging will not be accepted.	4;1
MH-04	<p>The shipper must provide a 24-hour emergency telephone number of a person/agency who is knowledgeable of the hazards, characteristics and actions to be taken in the case of an accident or incident concerning each of the dangerous goods being transported. This telephone number, including the country and area code, preceded by the words "Emergency contact" or "24-hour number", must be inserted in the "Additional handling information" box of the DGD.</p> <p>A 24-hour emergency telephone number is not required for shipments that do not require a shipper's declaration for dangerous goods.</p>	5;4
MH-05	<p>Dangerous goods in consolidations will not be accepted for carriage except for the following shipments:</p> <ul style="list-style-type: none"> — consolidated shipments/consolidations containing carbon dioxide, solid (dry ice) when used as a refrigerant; — one master air waybill with one house air waybill; or — one master air waybill with more than one house air waybill from the same shipper and different consignees. 	7;1
MH-06	Dangerous goods in excepted quantities will not be accepted for carriage.	3;5
MH-07	All dangerous goods must be secured to prevent movement and damage.	4;1 7;2
MH-08	UN 2803 — Gallium will not be carried under any circumstances.	Table 3-1
MH-09	UN 2211 — Polymeric beads, expandable, will not be accepted for carriage.	Table 3-1
MH-10	Class 8 — Corrosive materials (Packing Groups I and II) will not be accepted for carriage.	2;8 Table 3-1
MH-11	Explosives will not be accepted for carriage, except substances and articles of Division 1.4S.	2;1 Table 3-1
MH-12	UN 3166 — Engines, internal combustion and vehicle flammable liquid powered: if not able to be handled in other than an upright position, all fluids must be drained and the battery removed, e.g. motorcycles, lawnmowers, outboard motors and other vehicles, machines or equipment.	Table 3-1 4;11

MH-13	Material safety data sheets (MSDS) must be provided for dangerous goods except for dangerous goods in Class 7; vehicles; dangerous goods in apparatus or machinery and engines; ID 8000; magnetized material; carbon dioxide, solid (dry ice) and Division 6.2. The MSDS must be written in English. The MSDS must include the UN number, proper shipping name and other relevant transport information.	5;4
MH-14	Except for ID 8000 — Consumer commodity, dangerous goods in limited quantities (“Y” packing instructions) will not be accepted.	3;4
MH-15	Radioactive material in Type A packages will be accepted for carriage on passenger aircraft subject to the limitations of MH-18.	2;7 Table 3-1
MH-16	Radioactive material in Type B(U), Type B(M) and Type C packages will only be accepted for carriage on cargo aircraft.	2;7
MH-17	Class 7 — Fissile radioactive material will not be accepted.	2;7 Table 3-1
MH-18	The carriage of Class 7 — Radioactive material is subject to the following limitations: — maximum of 3.0 TI per package on passenger aircraft; — maximum 3.0 total sum of TI per narrow-body passenger aircraft; — maximum 25.0 total sum of TI per wide-body passenger aircraft; and — maximum 50.0 total sum of TI per cargo aircraft.	2;7 7;2
MK — AIR MAURITIUS		
MK-01	Class 7 — Radioactive material of categories White–I, Yellow–II and Yellow–III will be accepted for carriage provided the following conditions are complied with: — the radioactive material must be for medical diagnosis or medical research or treatment; or — to be used in analysis for medical purposes with direct relation to human health; and — the total transport index (TI) in one package or in group of packages must not exceed 3.0. The shipper’s declaration accompanying each shipment of radioactive material of categories White–I, Yellow–II or Yellow–III must show the following endorsement: “This radioactive material is intended for use in, or incidental to, medical research, diagnosis or treatment”.	5;1, 5;4
MK-02	Fireworks will not be accepted for carriage.	Table 3-1
MK-03	Class 1 — Explosives will not be accepted for carriage, with the exception of explosives in Division 1.4S, UN 0012 and UN 0014. UN 0323 will only be accepted as COMAT (aircraft parts), all packed for passenger aircraft.	2;1 Table 3-1
MK-04	Dangerous goods in excepted quantities will not be accepted for carriage.	3;5
MK-05	Shipper’s declarations must be in English and typewritten or computer-generated. Handwritten forms will not be accepted.	5;4
MK-06	Dangerous goods in limited quantities (“Y” packing instructions) will only be accepted for carriage under advance arrangement with the Air Mauritius Ground Services Department (Telephone: +230 603 3093/+203 603 3798) during office hours only.	3;4
MK-07	Infectious substances and biological products will not be accepted for carriage in airmail.	1;2,3 2;6
MK-08	The shipper must provide a 24-hour emergency telephone number of a person/agency who is knowledgeable of the hazards, characteristics and actions to be taken in case of an accident or incident concerning (each of) the dangerous goods being transported. This telephone number, including country and area code, preceded by the words “Emergency contact” or “24-hour number” must be inserted on the shipper’s declaration for dangerous goods (DGD) preferably in the “Handling information” box.	5;4
MK-09	The telephone number of the consignee must be shown on the air waybill.	5;4
MK-10	All hazard labels must include text indicating the nature of the risk. This text must appear prominently in English in the lower half of the label in addition to the class or division number or compatibility group as described in 7.2.2.4 of the IATA Dangerous Goods Regulations. This will be mandatory as from January 2010.	5;3

	MK-11	Single packagings are not acceptable for liquids of concentrates or essences with strongly irritating or smelling properties unless in sturdy, leakproof supplementary packaging forming an overpack for each single packaging used. The overpack must meet the marking, labelling and documentary requirements for an overpack and must bear orientation labels.	4;1 5;1, 5;2, 5;3
	MK-12	Dangerous goods in single packagings of UN specification 1A1, steel drums and 3A1, steel jerricans will not be accepted unless overpacked with, for example, suitably-sized wooden pallets to protect at least the top and bottom of the packaging.	6;1
	MK-13	Air Mauritius will not transport cargo only consignments (CAO) on its aircraft when operating cargo flights.	
	MK-14	Carriage of UN 1845 — Carbon dioxide, solid (dry ice) is subject to prior approval by Air Mauritius (see 2.3.4.6 of the IATA Dangerous Goods Regulations).	
+	MK-15	Air Mauritius will use its own oxygen kits on board its aircraft at a cost. For any special consideration, the approval of MK will be required. Passengers requiring therapeutic oxygen on board Air Mauritius aircraft must make necessary arrangements with the Air Mauritius Reservations Department at least 72 hours before departure (see 2.3.4.1 of the IATA Dangerous Goods Regulations).	8;1
	MN — COMAIR		
	MN-01	Dangerous goods, as defined by these regulations, will not be accepted for carriage, with the exception of those permitted for passengers and crew.	8;1
	MN-02	Oxygen or air. Small cylinders containing gaseous oxygen or air required for medical use are not permitted in passenger checked or carry-on baggage. Should a passenger require supplementary oxygen, this will be provided by the operator at a cost.	8;1
	MN-03	Non-infectious human blood samples classified as UN 3373 will be accepted for transportation provided they are accompanied by a doctor's letter. This is outside the company policy as specified in MN-01	2;6 Table 3-1
	MN-04	Bicycle inflation pumps filled with Division 2.2 carbon dioxide non-flammable gas will be accepted for transportation as checked baggage only. The maximum amount per passenger is limited to four 16 g cartridges. Cartridges larger than 16 g will not be permitted for carriage. This is outside the company policy as specified in MN-01.	8;1
≠	MP — MARTINAIR HOLLAND		
	MP-01	For Class 1 — Explosives, the shipper must obtain all authorizations required by the State(s) of origin, transit and destination. For transport and handling by MP, an approval must be obtained. Applications for an approval must be submitted via email to approval@klmcargo.com .	2;1 Table 3-1
	MP-02	Class 7 — Radioactive material, with the exception of UN 2908, UN 2909, UN 2910 and UN 2911, will not be accepted for transport and handling.	2;7 Table 3-1
	MP-03	Dangerous goods offered under State exemptions or approvals can be accepted pending approval of MP. Applications for an approval must be submitted via email to approval@klmcargo.com .	
	MP-04	Division 2.3 — Toxic gases will not be accepted for transport and handling.	2;2
	MP-05	The shipper must provide a 24-hour emergency telephone number of a person/agency who is knowledgeable of the hazards, characteristics and actions to be taken in the case of an accident or incident concerning each of the dangerous goods being transported. This telephone number, including the country and area code, preceded by wording indicating 24-hour availability must be inserted on the DGD.	5;4
	MS — EGYPTAIR		
	MS-01	The transport of dangerous goods on board Egyptair network must comply with the following: <ul style="list-style-type: none"> — the name, address and telephone number of the shipper/consignee must be written in full on the air waybill and on the package(s); — the shipper of any dangerous goods must provide a written undertaking to re-ship the consignment at the shipper's cost and risk if the consignment is not cleared, or received by the consignee, within fifteen (15) working days from the arrival of the consignment. 	

MS-02	Advance arrangements must be made for all shipments of dangerous goods as defined in the IATA Dangerous Goods Regulations.	
MS-03	Dangerous goods as defined in the IATA Dangerous Goods Regulations will not be accepted by post.	1;2,3
MS-04	Where any doubt arises regarding the classification or identification of a substance, the shipper must provide, upon request by Egyptair, the material safety data sheet (MSDS) for the substance which must include the transport information, or a declaration on company letterhead confirming the classification and assuming full liability.	5;4
MS-05	Dangerous goods in excepted quantities originating in Egypt will be accepted as dangerous goods according to the IATA Dangerous Goods Regulations. This provision does not apply to radioactive materials in excepted packages.	3;5
MS-06	Infected animals, dead or alive, will not be accepted on board Egyptair network.	2;6 Table 3-1
MS-07	For all types of radioactive material packages for import to Egypt (including excepted packages and for medical use), the shipper must notify the consignee and the station of destination before the arrival of the shipment by at least 48 hours. If the shipment is not cleared through customs within seven working days, the shipment will be returned to the originator on the shipper's account.	2;7 5;4

MU — CHINA EASTERN AIRLINES

MU-01	Fissile material will not be accepted.	7;1 Table 3-1
MU-02	Dangerous goods in consolidations will not be accepted, except for: <ul style="list-style-type: none"> — consolidations containing UN 1845, Carbon dioxide, solid (dry ice) when used as a refrigerant; — consolidations with only one house air waybill. 	7;1
MU-03	Dangerous goods in airmail originating from China will not be accepted for carriage.	1;2,3
MU-04	Fireworks originating from China will not be accepted for carriage.	Table 3-1
MU-05	Small gaseous oxygen or air cylinders required for medical use are not permitted in passenger checked or carry-on baggage. Should a passenger require supplementary oxygen, a prior request must be made to China Eastern Airlines.	8;1

M3 — ABSA CARGO

≠	M3-01	Dangerous goods offered for transport under an approval or an exemption as provided by 1.2.5 and 1.2.6 of the IATA Dangerous Goods Regulations and any other ABSA conditions by pre-approval will be accepted only after prior review and approval of the LATAM Dangerous Goods Technical Committee.	1;1.1
---	-------	--	-------

In addition, UN 1040 and UN 2014, when shipped as excepted quantities in accordance with Special Provisions A131 and A75 respectively, also require prior review and approval of the LATAM Dangerous Goods Technical Committee.

An application for approval must be undertaken at least fifteen working days in advance of the scheduled date for the flight. The material safety data sheet (MSDS) or other documentation that covers the shipment must be attached. Applications should be addressed to:

ABSA Dangerous Goods Department
Telephone: +55-19-2138-4454
+56-2-2677-4571 /+56-2-25669366
+1-305-772-2894
Email: DangerousGoodsBoard@lan.com

M3-02	<p>The shipper must provide a 24-hour emergency telephone number of a person/agency who is knowledgeable of the hazards, characteristics and actions to be taken in case of an accident or incident concerning each of the dangerous goods being transported. This telephone number, including the country and area code, preceded by the words "Emergency contact" or "24-hour number" must be inserted on the declaration for dangerous goods in the "Handling Information" box. (See 8.1.6.11 and 10.8.3.11 of the IATA Dangerous Goods Regulations.)</p> <p>An emergency response telephone number is not required for:</p> <ul style="list-style-type: none"> — battery-powered equipment; — battery-powered vehicle; — flammable gas-powered vehicle; — flammable liquid-powered vehicle; — engine, internal combustion; — dangerous goods in limited quantities as described in 3;4 of these Instructions (2.7 of the IATA Dangerous Goods Regulations); — carbon dioxide, solid (dry ice); — consumer commodity; and — refrigerating machines. 	Table 3-1 5;4
M3-03	<p>For toxic substances of Division 6.1 or Division 2.3, the following requirements must be complied with:</p> <ol style="list-style-type: none"> a) Toxic substances of Division 6.1, Packing Group I, that are toxic by inhalation, will not be accepted for carriage unless a prior approval has been obtained (see LA-01). b) Toxic gases of Division 2.3 will not be accepted for carriage unless a prior approval has been obtained (see LA-01). c) When the substance to be carried has an inhalation, mist, powder or vapour hazard, the shipper's declaration must have the following endorsement in the "Additional handling information box": "Mist, powder or vapour inhalation hazard", as appropriate. <ul style="list-style-type: none"> <i>Note 1.— This requirement only applies to the primary risk.</i> <i>Note 2.— Where the substance has more than one route of toxicity, the risk that determined the packing group must be used.</i> d) Solid toxic substances of any kind will not be accepted for carriage in bags 5H1, 5H2, 5H3, 5H4, 5L2, 5L3, 5M1 or 5M2 as single packagings unless contained in a strong hot sealed polyethylene bag at least 200 microns thick. If these types of packages are offered overpacked in a warehouse pallet, they will be accepted for carriage provided: <ol style="list-style-type: none"> 1) the warehouse pallet is rigid and strong enough to support the weight assembled on it, without bending when picked up and transported by a forklift; 2) the surface of the warehouse pallet is continuous, soft and free of sharp protruding points which could pierce the bags; and 3) the warehouse pallet is provided with separation bars from the floor for the use of a forklift. 	2;3 2;6 5;4 6;1

M3-04	Infectious substances will be accepted under specific advance arrangements and the following requirements must be met:	2;6.3.2.3.6 5;4
	<ul style="list-style-type: none"> a) The shipper must prove by a document such as a fax, telex, letter, etc., that the infectious substance can legally enter the State of Destination and that all the requirements of the States of Origin and Destination of the shipment have been complied with. b) The shipper must attach a certificate duly signed and issued by a medical, scientific or other similar professional which confirms the classification of these specimens in the following cases: <ul style="list-style-type: none"> — shipment of Biological substance, Category B; — shipment of any patient specimens prepared according to 3.6.2.2.3.6 of the IATA Dangerous Goods Regulations. c) Infected animals, dead (whole bodies) or alive will not be accepted for carriage. 	
M3-05	Formaldehyde solutions containing less than 25% of formaldehyde must be shipped under UN 3334 — Aviation regulated liquid, n.o.s.*, Class 9, Packing Group III.	Table 3-1
M3-06	The marking required by 7.1.5 of the IATA Dangerous Goods Regulations and application of hazard and handling labels on packages containing dangerous goods must not be applied to the top or bottom of packages. These markings and labels must be applied to the sides of packages. This requirement does not apply to marking of the full name and address of the shipper and consignee.	5;2 5;3
M3-07	Fissile material as defined in 10.3.7 of the IATA Dangerous Goods Regulations will be accepted only with prior review and approval by the LAN Dangerous Goods Technical Committee (see LA-01).	1;6.1.5 2;7
+ M3-08	UN 3090 — Lithium metal batteries and UN 3091 — Lithium metal batteries contained in or packed with equipment. Primary (non-rechargeable) lithium (metal) batteries and cells must be transported on cargo aircraft only (CAO). This prohibition does not apply to: <ul style="list-style-type: none"> — lithium batteries (rechargeable and non-rechargeable) covered by the provisions for dangerous goods carried by passengers or crew. (See Table 2.3.A of the IATA Dangerous Goods Regulations.); — lithium metal batteries and cells contained in medical equipment being transported for humanitarian reasons; — lithium metal batteries and cells that are presented as COMAT of any air company of LATAM Airlines Group. 	Table 3-1 4;11 8;1
+ M3-09	Unit load devices or freight containers containing dangerous goods described in 9.1.4, sub-paragraphs (a) to (d) of the IATA Dangerous Goods Regulations or lithium batteries prepared under Section II of Packing Instructions 965 to 970 will be accepted by advance arrangements and contract only in accordance with the current "Accreditation Freight Forwarder Programme" implemented by the ABSA Dangerous Goods Department (see M3-01). The shipper/freight forwarder must deliver a document certifying that: <ul style="list-style-type: none"> — the shipment was prepared on secure premises and protected against unlawful interference during preparation, storage and transport; and — packages comply with all requirements of the IATA Dangerous Goods Regulations. 	7;1.4
+ M3-10	UN 3356 — Chemical oxygen generators transported to, from, through or within the United States must be placed in outer packaging that bears the additional tested specification mark of DOT 31FP indicating compliance with 49 CFR 173.168.	4;7

M7 — MASAIR — AEROTRANSPORTES MAS DE CARGA SA. DE CV.

≠ M7-01 Dangerous goods offered for transport under an approval or an exemption as provided by 1.2.5 and 1.2.6 of the IATA Dangerous Goods Regulations and any other MASAIR conditions by pre-approval will be accepted only after prior review and approval of the LATAM Dangerous Goods Technical Committee. 1;1.1

In addition, UN 1040 and UN 2014, when shipped as excepted quantities in accordance with Special Provisions A131 and A75 respectively, also require prior review and approval of the LATAM Dangerous Goods Technical Committee.

An application for approval must be undertaken at least fifteen working days in advance of the scheduled date for the flight. The material safety data sheet (MSDS) or other documentation that covers the shipment must be attached. Applications should be addressed to:

MASAIR Dangerous Goods Department
 Telephone: +56-2-694-7898
 +56-2-677-4571
 +1-305-772-2894
 Email: DangerousGoodsBoard@lan.com

M7-02 The shipper must provide a 24-hour emergency telephone number of a person/agency who is knowledgeable of the hazards, characteristics and actions to be taken in case of an accident or incident concerning each of the dangerous goods being transported. This telephone number, including the country and area code, preceded by the words "Emergency contact" or "24-hour number" must be inserted on the declaration for dangerous goods in the "Handling Information" box. (See 8.1.6.11 and 10.8.3.11 of the IATA Dangerous Goods Regulations.) Table 3-1
5;4

An emergency response telephone number is not required for:

- battery-powered equipment;
- battery-powered vehicle;
- flammable gas-powered vehicle;
- flammable liquid-powered vehicle;
- engine, internal combustion;
- dangerous goods in limited quantities as described in 3;4 of these Instructions (2.7 of the IATA Dangerous Goods Regulations);
- carbon dioxide, solid (dry ice);
- consumer commodity; and
- refrigerating machines.

M7-03	For toxic substances of Division 6.1 or Division 2.3, the following requirements must be complied with:	2;3 2;6 5;4 6;1
	<ul style="list-style-type: none"> a) Toxic substances of Division 6.1, Packing Group I, that are toxic by inhalation, will not be accepted for carriage unless a prior approval has been obtained (see LA-01). b) Toxic gases of Division 2.3 will not be accepted for carriage unless a prior approval has been obtained (see LA-01). c) When the substance to be carried has an inhalation, mist, powder or vapour hazard, the shipper's declaration must have the following endorsement in the "Additional handling information box": "Mist, powder or vapour inhalation hazard", as appropriate. <i>Note 1.— This requirement only applies to the primary risk.</i> <i>Note 2.— Where the substance has more than one route of toxicity, the risk that determined the packing group must be used.</i> d) Solid toxic substances of any kind will not be accepted for carriage in bags 5H1, 5H2, 5H3, 5H4, 5L2, 5L3, 5M1 or 5M2 as single packagings unless contained in a strong hot sealed polyethylene bag at least 200 microns thick. If these types of packages are offered overpacked in a warehouse pallet, they will be accepted for carriage provided: <ul style="list-style-type: none"> 1) the warehouse pallet is rigid and strong enough to support the weight assembled on it, without bending when picked up and transported by a forklift; 2) the surface of the warehouse pallet is continuous, soft and free of sharp protruding points which could pierce the bags; and 3) the warehouse pallet is provided with separation bars from the floor for the use of a forklift. 	
M7-04	Infectious substances will be accepted under specific advance arrangements and the following requirements must be met:	2;6.3.2.3.6 5;4
	<ul style="list-style-type: none"> a) The shipper must prove by a document such as a fax, telex, letter, etc., that the infectious substance can legally enter the State of Destination and that all the requirements of the States of Origin and Destination of the shipment have been complied with. b) The shipper must attach a certificate duly signed and issued by a medical, scientific or other similar professional which confirms the classification of these specimens in the following cases: <ul style="list-style-type: none"> — shipment of Biological substance, Category B; — shipment of any patient specimens prepared according to 3.6.2.2.3.6 of the IATA Dangerous Goods Regulations. c) Infected animals, dead (whole bodies) or alive will not be accepted for carriage. 	
M7-05	Formaldehyde solutions containing less than 25% of formaldehyde must be shipped under UN 3334 — Aviation regulated liquid, n.o.s.*, Class 9, Packing Group III.	Table 3-1
M7-06	The marking required by 7.1.5 of the IATA Dangerous Goods Regulations and application of hazard and handling labels on packages containing dangerous goods must not be applied to the top or bottom of packages. These markings and labels must be applied to the sides of packages. This requirement does not apply to marking of the full name and address of the shipper and consignee.	5;2 5;3
M7-07	Fissile material as defined in 10.3.7 of the IATA Dangerous Goods Regulations will be accepted only with prior review and approval by the LAN Dangerous Goods Technical Committee (see LA-01).	1;6.1.5 2;7
+ M7-08	UN 3090 — Lithium metal batteries and UN 3091 — Lithium metal batteries contained in or packed with equipment. Primary (non-rechargeable) lithium (metal) batteries and cells must be transported on cargo aircraft only (CAO).	Table 3-1 4;11 8;1

This prohibition does not apply to:

- lithium batteries (rechargeable and non-rechargeable) covered by the provisions for dangerous goods carried by passengers or crew. (See Table 2.3.A of the IATA Dangerous Goods Regulations.);
- lithium metal batteries and cells contained in medical equipment being transported for humanitarian reasons;
- lithium metal batteries and cells that are presented as COMAT of any air company of LATAM Airlines Group.

- + M7-09 Unit load devices or freight containers containing dangerous goods described in 9.1.4, sub-paragraphs (a) to (d) of the IATA Dangerous Goods Regulations or lithium batteries prepared under Section II of Packing Instructions 965 to 970 will be accepted by advance arrangements and contract only in accordance with the current “Accreditation Freight Forwarder Programme” implemented by the ABSA Dangerous Goods Department (see M7-01). 7;1.4

The shipper/freight forwarder must deliver a document certifying that:

- the shipment was prepared on secure premises and protected against unlawful interference during preparation, storage and transport; and
- packages comply with all requirements of the IATA Dangerous Goods Regulations.

- + M7-10 UN 3356 — Chemical oxygen generators transported to, from, through or within the United States must be placed in outer packaging that bears the additional tested specification mark of DOT 31FP indicating compliance with 49 CFR 173.168. 4;7

NF — AIR VANUATU

- NF-01 Radioactive material, including all categories of excepted packages, will not be accepted for transport. 2;7

>

NH — ALL NIPPON AIRWAYS

- NH-01 Advance arrangements must be made for all shipments of dangerous goods as defined in these Instructions.
- NH-02 Not used.
- NH-03 Type B(M), Type C, fissile material (excluding fissile-excepted) packages, SCO and LSA material in industrial packagings will not be accepted for carriage. 2;7
5;1.1
- NH-04 Not used.
- NH-05 Dangerous goods in salvage packagings will not be accepted for carriage. 4;1
- NH-06 Dangerous goods packed in single metal packagings (1A1, 1A2, 1B1, 1B2, 3A1, 3A2, 3B1 and 3B2) are not acceptable for carriage unless an overpack is used. 6;1

NZ — AIR NEW ZEALAND

- ≠ NZ-01 Not used.
- NZ-02 Machinery incorporating internal combustion engines fuelled by petrol are to be classified as “Engine, internal combustion, flammable liquid powered”; (UN 3166) whether they are used or new, unless the shipper can present a certificate that certifies that the fuel tank and fuel system have been purged of fuel. Table 3-1

Such machinery includes chainsaws, motor mowers, weed eaters, leaf blowers, etc.

+	<p>NZ-03 The shipper must provide a 24-hour emergency telephone number of a person/agency who is knowledgeable of the hazards, characteristics and actions to be taken in the case of an accident or incident concerning each of the dangerous goods being transported. This telephone number, including the country and area code, preceded by the words "Emergency Contact" or "24-hour number" must be inserted on the shipper's declaration for dangerous goods, preferably in the "Handling Information" box, e.g. "Emergency Contact +1 514-123-4567" (see 8.1.6.11 and 10.8.3.11 of the IATA Dangerous Goods Regulations).</p> <p>A 24-hour emergency telephone number is not required for shipments that do not require a shipper's declaration for dangerous goods.</p> <p>OK — CZECH AIRLINES</p> <p>OK-01 Dangerous goods as defined in these Instructions will not be accepted in airmail.</p> <p>OK-02 Not used.</p> <p>OK-03 Fissile radioactive material will not be accepted for carriage.</p> <p>OK-04 Liquid dangerous goods packed in single metal packagings (1A1, 1A2, 1B1, 1B2) will not be accepted unless safely overpacked to protect the base of the packaging. (See 5.0.1.5 of the IATA Dangerous Goods Regulations.)</p> <p>OK-05 Small oxygen cylinders containing gaseous oxygen or air required for medical use are not permitted on the person or in checked or carry-on baggage. Czech Airlines provides oxygen cylinders at the request of passengers at the time of booking, but at least 48 hours in advance.</p>	<p>5;4</p> <p>1;2,3</p> <p>2;7 Table 3-1</p> <p>4;1 6;1</p> <p>8;1</p>
≠	<p>OM — MONGOLIAN AIRLINES</p> <p>OM-01 Reservations must be made well in advance for any shipment containing dangerous goods as defined in the IATA Dangerous Goods Regulations (see 1.3.2 and 9.1.2 of the IATA Dangerous Goods Regulations). Dangerous goods without booking will be rejected.</p> <p>OM-02 Dangerous goods shipments will only be accepted from an IATA dangerous goods regulations certified cargo agency/shipper.</p> <p>OM-03 The shipper must provide a 24-hour emergency telephone number of a person/agency who is knowledgeable of the hazards, characteristics and actions to be taken in the case of an accident or incident concerning each of the dangerous goods being transported. This telephone number, including the country and area code, preceded by the words "Emergency Contact" or "24-hour number" must be inserted on the shipper's declaration for dangerous goods, preferably in the "Handling Information" box, e.g. "Emergency Contact +976-11-70049998" (see 8.1.6.11 and 10.8.3.11 of the IATA Dangerous Goods Regulations).</p> <p>OM-04 Documentation, including the shipper's declaration for dangerous goods (DGD), must be completed in English. All package and overpack markings and labellings required by the IATA Dangerous Goods Regulations must be completed in English.</p> <p>OM-05 The carriage of UN 1845 — Carbon dioxide, solid (dry ice) will be limited to a maximum net weight of 200 kg per B767-300 and B737-800 aircraft.</p> <p>OM-06 The following metal packagings without overpack are not acceptable for single packaging:</p> <ul style="list-style-type: none"> — 1A1/1A2/1B1/1B2/1N1/1N2 — 3A1/3A2/3B1/3B2. <p>These packagings must be overpacked to protect the top and bottom of the packaging (see 7.1.4, 7.2.3.10 of the IATA Dangerous Goods Regulations).</p> <p>OM-07 All dangerous goods packed in single packagings of UN specification "1A1" or "1A2" (steel drums) or "6HA1" (composite packagings, plastic receptacle with outer steel drum) are not acceptable for carriage unless overpacked with suitably-sized wooden pallets to protect the top and the bottom of the packaging.</p> <p>OM-08 Dangerous goods requiring a cargo aircraft only (CAO) label will not be accepted for carriage.</p> <p>OM-09 Dangerous goods in airmail will not be accepted for carriage.</p>	<p>5;1,1 7;1,2</p> <p>5;4</p> <p>5;2 5;3</p> <p>Table 3-1 7;2</p> <p>6;1</p> <p>5;1,1 e) 5;1,1 f) 5;2,4.10 5;3,3</p> <p>4;1</p> <p>5;3</p> <p>1;2,3</p>

OM-10	Dangerous goods in “limited quantities” (“Y” packing instructions) will not be accepted for carriage. Exception: ID 8000 — Consumer commodity will be accepted. (See 3;4 of these Instructions, 2.7 of the IATA Dangerous Goods Regulations and all “Y” packing instructions.)	3;4
OM-11	Dangerous goods in excepted quantities will not be accepted for carriage. <i>Note.— The above requirement does not apply to company material (COMAT).</i>	3;5
OM-12	Dangerous goods in consolidations will not be accepted for carriage.	7;2
OM-13	Salvage packaging will not be accepted for carriage.	4;1
OM-14	Class 7 — Radioactive material of any kind will not be accepted for carriage.	2;7
OM-15	Dangerous goods in Packing Group I will not be accepted. <i>Note.— The above requirement does not apply to company material (COMAT).</i>	Table 3-1
OM-16	Dangerous goods listed in the list of high consequence dangerous goods will not be accepted for carriage. <i>Note.— The above requirement does not apply to company material (COMAT).</i>	Table 1-7
OM-17	Dangerous goods originating from China will not be accepted for carriage <i>Note.— The above requirement does not apply to company material (COMAT).</i>	
OM-18	Class 1 — Explosives will not be accepted for carriage, except for Class 1.4S. <i>Note.— The above requirement does not apply to company material (COMAT).</i>	2;1 Table 3-1
OM-19	Hazardous waste in any form, as defined by any regulation, will not be accepted for carriage (see Packing Instruction 622 and 8.1.3.3 of the IATA Dangerous Goods Regulations).	4;8 5;1.1
OM-20	Lithium metal or lithium alloy cells and batteries (UN 3090), including those approved by an appropriate authority under Special Provision A88 or A99 and packed in accordance with Packing Instruction 968 and lithium metal and or lithium alloy cells and batteries packed with or contained in equipment (UN 3091) are prohibited from carriage as cargo on OM flights/aircraft (see Packing Instructions 968, 969 and 970). <i>Note.— The above requirement does not apply to company material (COMAT).</i>	Table 3-1 3;3 4;11
OM-21	UN 3356 — Oxygen generator, chemical are forbidden from carriage on OM aircraft. <i>Note.— The above requirement does not apply to company material (COMAT).</i>	2;5 Table 3-1
OM-22	Not used.	
OM-23	Wheelchairs or other battery-powered mobility devices with spillable batteries will be accepted only when the battery is removed from the wheelchair or mobility device. The spillable battery, classified as dangerous goods, can only be carried as cargo (see 2.3.2.3 and 9.3.15 of the IATA Dangerous Goods Regulations). Batteries attached to or installed in the wheelchair or mobility device will not be accepted (see 9.3.15 of the IATA Dangerous Goods Regulations).	8;1
OM-24	Gas cylinders in Division 2.2 (non-flammable, non-toxic) will not be permitted as baggage. Cylinders containing Division 2.1 and/or Division 2.3 gases will not be permitted as baggage.	8;1
OM-25	Any type of internal combustion or fuel cell engine either transported individually or incorporated into another machine or equipment, even when still in its new original packaging, will not be accepted as baggage. It may only be carried as cargo in accordance with the requirements of the IATA Dangerous Goods Regulations.	8;1
OM-26	Camping stoves and fuel containers that have contained a flammable liquid fuel will not be accepted for carriage in baggage. This variation applies also to used camping stoves which have been thoroughly cleaned (see 2.3.2.5 of the IATA Dangerous Goods Regulations).	8;1
>		
OS — AUSTRIAN AIRLINES		
OS-01	UN 3481 — Lithium ion batteries contained in equipment, Packing Instruction 967, Section I (battery/pack more than 100 Wh) will not be accepted for carriage as cargo.	4;11

≠	OS-02	Not used.	
	OS-03	Dangerous goods in limited quantities (“Y” packing instructions) will not be accepted for carriage. (Exception: ID 8000 — Consumer commodity will be accepted.) (See 3;4 of these Instructions, 2.7 of the IATA Dangerous Goods Regulations and all “Y” packing instructions.)	3;4
	OS-04	UN 3373 — Biological substance, Category B, will not be accepted in airmail.	1;2,3 Table 3-1
OU — CROATIA AIRLINES			
	OU-01	Advance arrangements must be made for all shipments of dangerous goods as defined in the IATA Dangerous Goods Regulations. (See 1.3.2 and 9.1.2 of the IATA Dangerous Goods Regulations.)	
	OU-02	Small gaseous oxygen or air cylinders required for medical use will only be accepted empty as checked baggage. Should a passenger require supplementary oxygen, this will be provided by the operator at a cost with prior arrangements. (See 2.3.4.1 of the IATA Dangerous Goods Regulations.)	8;1
≠	OU-03	Camping stoves and fuel containers that have contained a flammable liquid fuel will not be accepted in passenger baggage (see 2.3.2.5 of the IATA Dangerous Goods Regulations).	8;1
	OU-04	Dangerous goods in “limited quantities” (“Y” packing instructions) will not be accepted for carriage, except for ID 8000 — Consumer commodity. (See 2.7 of the IATA Dangerous Goods Regulations and all Y packing instructions.)	3;4
	OU-05	Not used.	
	OU-06	Biological substances, Category B (UN 3373), will not be accepted in airmail.	1;2,3 Table 3-1
	OU-07	Oxygen generators, chemical (UN 3356) will not be accepted.	Table 3-1
	OU-08	Dangerous Goods in salvage packagings will not be accepted for carriage. (See 5.0.1.6, 6.0.6, 6.7, 7.1.5 and 7.2.3.11 of the IATA Dangerous Goods Regulations).	4;1
	OU-09	Class 7 — Fissile radioactive materials will not be accepted for carriage.	2;7 Table 3-1
	OU-10	The shipper must provide a 24-hour emergency telephone number of a person/agency who is knowledgeable of the hazards, characteristics and actions to be taken in the case of an accident or incident concerning each of the dangerous goods being transported. This telephone number, including the country and area code, preceded by the words “Emergency contact” or “24-hour number” must be inserted on the shipper’s declaration for dangerous goods (DGD) preferably in the Additional handling information box, e.g. “Emergency contact +47 67 50 00 00”. (See 8.1.6.11 and 10.8.3.11 of the IATA Dangerous Goods Regulations.) A 24-hour emergency telephone number is not required for shipments that do not require a DGD.	5;4
	OU-11	Explosives will not be accepted for carriage, except substances and articles of Division 1.4S. (See 3.1 and 5.1 of the IATA Dangerous Goods Regulations and Packing Instructions 101-143.)	2;1 Table 3-1
	OU-12	Infected animals, dead or alive, will not be accepted for carriage.	2;6 Table 3-1
	OU-13	Not used.	
	OU-14	Dangerous goods in consolidations will not be accepted for carriage, except for UN 1845, Carbon dioxide, solid (dry ice) when used as a refrigerant. (See 1.3.3, 8.1.2, 9.1.8 and 10.8.1.5 of the IATA Dangerous Goods Regulations.)	7;1, 7;2
	OU-15	Self-inflating rafts, aircraft survival kits, or evacuation slides, are limited to not more than one per aircraft, packed in accordance with Packing Instruction 955 of the IATA Dangerous Goods Regulations.	4;11
≠	OU-16	Not used.	

OZ — ASIANA			
	OZ-01	Advance arrangements must be made for all shipments of dangerous goods as defined in the IATA Dangerous Goods Regulations. Dangerous goods without booking will be rejected.	
≠	OZ-02	Dangerous goods in consolidations will be accepted for carriage provided the number of the house air waybill appears after the air waybill number separated by “/” on the shipper’s declaration for dangerous goods.	7;1
	OZ-03	Class 1 — Explosives are acceptable for carriage provided that prior approval has been received from Asiana Airlines. This does not apply to COMAT parts and supplies containing explosives, and small quantities of ammunition in passenger baggage permitted by 2.3.2.2 of the IATA Dangerous Goods Regulations. Contact for additional information or operator approval is: Asiana Airlines, Cargo Service Team P.O. Box 400-340 # 2165-160 Woonseo-Dong Joong-Gu, Incheon, Korea Fax: +82-32-744-2779 Email: aacy@flyasiana.com	2;1 Table 3-1 8;1
	OZ-04	Class 3 — Flammable liquids in Packing Group I will not be accepted for carriage.	2;3 Table 3-1
≠	OZ-05	Oxygen generator, chemical — UN 3356 will not be accepted for carriage (exception: COMAT).	Table 3-1
	OZ-06	Class 7 — Radioactive material: Type B(M), fissile material and Type C packages will not be accepted for carriage.	2;7 Table 3-1 5;1
	OZ-07	Class 7 — Radioactive material: Type B(U) packages will only be accepted for carriage on cargo aircraft.	2;7 Table 3-1
≠	OZ-08	All liquid dangerous goods shipments must be packed in accordance with the following requirements in addition to specified packing instructions: a) single packagings and composite packagings including single packaging code 1A1, 1A2 and composite packaging code 6HA1 with a net quantity of no more than 20 L must be overpacked by a strong wooden crate; b) single packaging code 1A1, 1A2 and composite packaging code 6HA1 with a net quantity of more than 20 L must be overpacked on a suitably sized wooden or plastic pallet to protect at least the top and bottom of the packaging.	4;1 6;1
+	OZ-09	Dangerous goods will not be accepted for carriage as cargo on OZ’s passenger aircraft with the exception of: — dangerous goods in excepted quantities; — radioactive material, excepted packages; — UN 1845 — Carbon dioxide, solid (dry ice) — UN 2807 — Magnetized material — UN 3166 — Engines, internal combustion, flammable liquid powered — UN 3166 — Engine, fuel cell, flammable liquid powered — UN 3166 — Vehicle, flammable liquid powered — UN 3091 — Lithium metal batteries packed with equipment (Packing Instruction 969, Section II only) — UN 3091 — Lithium metal batteries contained in equipment (Packing Instruction 970, Section II only) — UN 3480 — Lithium ion batteries (Packing Instruction 965, Section IB and II only) — UN 3481 — Lithium ion batteries packed with equipment (Packing Instruction 966, Section II only) — UN 3481 — Lithium ion batteries contained in equipment (Packing Instruction 967, Section II only)	3;5
+	OZ-10	UN 3090 — Lithium metal batteries and cells packed in accordance with Section IA, IB or II of Packing Instruction 968 and UN 3091 — Lithium metal batteries packed with or contained in equipment packed in accordance with Section I of Packing Instruction 969 or Packing Instruction 970 are prohibited from carriage as cargo on Asiana aircraft.	Table 3-1 4;11

+	OZ-11	UN 3480 — Lithium ion batteries and cells packed in accordance with Section IA of Packing Instruction 965 and UN 3481 — Lithium ion batteries packed with or contained in equipment packed in accordance with Section I of Packing Instruction 966 or 967 are prohibited from carriage as cargo on Asiana aircraft.	Table 3-1 4;11
+	OZ-12	Vehicles fitted with lithium batteries and electric vehicles with lithium batteries are forbidden from carriage (see Packing Instructions 950, 951 and 952).	Table 3-1 4;11
PG — BANGKOK AIRWAYS			
	PG-01	Dangerous goods, as defined by the IATA Dangerous Goods Regulations, will not be accepted for carriage, with the exception of those articles and substances permitted for passengers and crew. (See 2.3 and Table 2.3.A of the IATA Dangerous Goods Regulations.)	8;1
	PG-02	Commercial shipments of dangerous goods will not be accepted. Properly prepared company material (COMAT), aircraft spares shipments will be accepted. (See 2.5.2 of the IATA Dangerous Goods Regulations.)	7;1
		<i>Note.— Contact for additional information, evaluation or operator approval is:</i>	
		Jirapon Hirunrat (Mr.) Senior Flight Operations Control Manager BANGKOK AIRWAYS CO., LTD. 2FL, Bangkok Air Operations Complex 999 Mu. 4 Bangna-Tart Road, Bangchalong Bangplee, Samutprakarn 10540 THAILAND Tel: +662 328 3309, +662 328 3306 Fax: +662 325 0647 Email: jirapon@bangkokair.com Email: bkkocc@bangkokair.com AFTN: VTBSBKPX SITA: BKKOCPG	
PL — AEROPERU			
	PL-01	No explosives are accepted for transport by air.	2;1 Table 3-1
≠	PR — PHILIPPINE AIRLINES		
	PR-01	Only the following dangerous goods under Class 1 — Explosives, Division 1.4S, are acceptable to Philippine Airlines for air carriage (see packing instructions [–] listed after each substance):	2;1 Table 3-1
		UN 0012 — Cartridges for weapons, inert projectile [130] UN 0012 — Cartridges, small arms [130] UN 0014 — Cartridges for weapons, blank [130] UN 0014 — Cartridges, small arms, blank [130] UN 0044 — Primers, cap type [133] UN 0055 — Cases, cartridge, empty, with primer [136] UN 0323 — Cartridges, power device [134] UN 0405 — Cartridges, signal [135].	
	PR-02	Fuel containers for camping stoves that have contained a flammable liquid fuel will not be accepted for carriage as checked baggage.	8;1
PS — UKRAINE INTERNATIONAL AIRLINES			
	PS-01	Radioactive materials are not accepted for carriage on passenger aircraft. This requirement does not apply to excepted packages as defined in 10.5.8 of the IATA Dangerous Goods Regulations.	2;7
PX — AIR NIUGINI			
	PX-01	All package and overpack markings required by these Instructions must be in English. If the State of Origin requires markings in a language other than English, both languages are to be given equal prominence.	5;2

PX-02	All hazard labels must include text indicating the nature of the risk. This text must appear prominently in English in the lower half of the label as described in 7.2.2.4 of the IATA Dangerous Goods Regulations. If the State of Origin requires text in a language other than English, both languages are to be given equal prominence.	5;3
PX-03	Dangerous goods in consolidations are not permitted on PX services and airlines handled by PX except for dry ice when used as a refrigerant.	7;1
PX-04	Radioactive material shipments for both inbound and outbound (Type A/Type B(U)) will only be accepted on PX services and airlines handled by PX if prior approval is in place. Such approval must be in place at least one week prior to date of uplift. For approval refer to: Cargo Systems and Training Air Niugini P.O. Box 7186 Boroko Papua New Guinea TTY: POMFUPX or POMFBPX Attn: Cargo Training and Systems Office	2;7 5;1
PX-05	Dangerous goods offered under the provisions of “Excepted quantities” will not be accepted on PX services. However, this item can only be accepted with prior approval from PX.	3;5
PX-06	Division 4.1 — Flammable solids — Book matches taken into aircraft cabin by crew and passengers for personal use are not permitted. Such items must be declared as dangerous goods through PX cargo agent offices.	8;1
PX-07	Material safety data sheets (MSDS) must be provided for dangerous goods except for dangerous goods in Class 7, UN 2794, UN 3166, UN 3363, UN 3358, ID 8000, magnetized material, carbon dioxide, solid (dry ice), Division 6.2. The MSDS must be written in English. The material safety data sheet must include the UN number, proper shipping name and other relevant transport information. This variation only applies to shipments within and from Papua New Guinea and does not apply to transshipments from an international origin.	Table 3-1 5;4
PX-08	Infectious substances packed in accordance with Packing Instruction 650 are not permitted in the passenger cabin and must be lodged as cargo.	2;6 4;7
PX-09	All outbound dangerous goods accepted through freight forwarders and cargo agents must be checked by the agent’s certified personnel before lodging it with the operator. A copy of the checklist must be attached. This variation only applies to shipments within and from Papua New Guinea and does not apply to transshipments from an international origin.	5;4
PX-010	Dangerous goods in limited quantities (“Y” packing instructions) will not be accepted by PX and airlines handled by PX, except for dangerous goods in Class 9.	
PZ — TRANSPORTES DEL MERCOSUL — TAM		
≠	PZ-01 Dangerous goods offered for transport under an approval or an exemption as provided by 1.2.5 and 1.2.6 of the IATA Dangerous Goods Regulations and any other Transportes del Mercosur — TAM Airlines conditions by pre-approval will be accepted only after prior review and approval of the LATAM Dangerous Goods Technical Committee. In addition, UN 1040 and UN 2014, when shipped as excepted quantities in accordance with Special Provisions A131 and A75 respectively, also require prior review and approval of the LATAM Dangerous Goods Technical Committee. An application for approval must be undertaken at least fifteen working days in advance of the scheduled date for the flight. The material safety data sheet (MSDS) or other documentation that covers the shipment must be attached. Applications should be addressed to: TAM Dangerous Goods Department Telephone: +55 11 55827626 +56-2-2677-4571/+56-2-25669366 +1-305-772-2894 Email: saofy@tam.com.br and DangerousGoodsBoard@lan.com	1;1.1 Table 3-1

≠	PZ-02	<p>The shipper must provide a 24-hour emergency telephone number of a person/agency who is knowledgeable of the hazards, characteristics and actions to be taken in case of an accident or incident concerning each of the dangerous goods being transported. This telephone number, including the country and area code, preceded by the words "Emergency contact" or "24-hour number" must be inserted on the declaration for dangerous goods in the "Handling Information" box. (See 8.1.6.11 and 10.8.3.11 of the IATA Dangerous Goods Regulations.)</p> <p>An emergency response telephone number is not required for:</p> <ul style="list-style-type: none"> — battery-powered equipment; — battery-powered vehicle; — flammable gas-powered vehicle; — flammable liquid-powered vehicle; — engine, internal combustion; — dangerous goods in limited quantities as described in 3;4 of these Instructions (2.7 of the IATA Dangerous Goods Regulations); — carbon dioxide, solid (dry ice); — consumer commodity; and — refrigerating machines. 	5;4
≠	PZ-03	<p>For toxic substances of Division 6.1 or Division 2.3, the following requirements must be complied with:</p> <ol style="list-style-type: none"> a) Toxic substances of Division 6.1, Packing Group I, that are toxic by inhalation, will not be accepted for carriage unless a prior approval has been obtained (see PZ-01). b) Toxic gases of Division 2.3 will not be accepted for carriage unless a prior approval has been obtained (see PZ-01). c) When the substance to be carried has an inhalation, mist, powder or vapour hazard, the shipper's declaration must have the following endorsement in the "Additional handling information box": "Mist, powder or vapour inhalation hazard", as appropriate. <ul style="list-style-type: none"> <i>Note 1.— This requirement only applies to the primary risk.</i> <i>Note 2.— Where the substance has more than one route of toxicity, the risk that determined the packing group must be used.</i> d) Solid toxic substances of any kind will not be accepted for carriage in bags 5H1, 5H2, 5H3, 5H4, 5L2, 5L3, 5M1 or 5M2 as single packagings unless contained in a strong hot sealed polyethylene bag at least 200 microns thick. If these types of packages are offered overpacked in a warehouse pallet, they will be accepted for carriage provided: <ol style="list-style-type: none"> 1) the warehouse pallet is rigid and strong enough to support the weight assembled on it, without bending when picked up and transported by a forklift; 2) the surface of the warehouse pallet is continuous, soft and free of sharp protruding points which could pierce the bags; and 3) the warehouse pallet is provided with separation bars from the floor for the use of a forklift. 	2;3 2;6 5;4 6;1

≠	PZ-04	<p>Infectious substances will be accepted under specific advance arrangements and the following requirements must be met:</p> <p>a) The shipper must prove by a document such as a fax, telex, letter, etc., that the infectious substance can legally enter the State of Destination and that all the requirements of the States of Origin and Destination of the shipment have been complied with.</p> <p>b) The shipper must attach a certificate duly signed and issued by a medical, scientific or other similar professional which confirms the classification of these specimens in the following cases:</p> <ul style="list-style-type: none"> — shipment of Biological substance, Category B; — shipment of any patient specimens prepared according to 3.6.2.2.3.6 of the IATA Dangerous Goods Regulations. <p>c) Infected animals, dead (whole bodies) or alive will not be accepted for carriage.</p>	7;2
+	PZ-05	<p>Formaldehyde solutions containing less than 25% of formaldehyde must be shipped under UN 3334 — Aviation regulated liquid, n.o.s.*, Class 9, Packing Group III.</p>	Table 3-1
+	PZ-06	<p>The marking required by 7.1.5 of the IATA Dangerous Goods Regulations and application of hazard and handling labels on packages containing dangerous goods must not be applied to the top or bottom of packages. These markings and labels must be applied to the sides of packages. This requirement does not apply to marking of the full name and address of the shipper and consignee.</p>	5;2 5;3
+	PZ-07	<p>Fissile material as defined in 10.3.7 of the IATA Dangerous Goods Regulations will be accepted only with prior review and approval by the LATAM Dangerous Goods Technical Committee (see PZ-01).</p>	1;6.1.5 2;7
+	PZ-08	<p>UN 3090 — Lithium metal batteries and UN 3091 — Lithium metal batteries contained in or packed with equipment. Primary (non-rechargeable) lithium (metal) batteries and cells must be transported on cargo aircraft only (CAO).</p> <p>This prohibition does not apply to:</p> <ul style="list-style-type: none"> — lithium batteries (rechargeable and non-rechargeable) covered by the provisions for dangerous goods carried by passengers or crew. (See Table 2.3.A of the IATA Dangerous Goods Regulations.); — lithium metal batteries and cells contained in medical equipment being transported for humanitarian reasons; — lithium metal batteries and cells that are presented as COMAT of any air company of LATAM Airlines Group. 	Table 3-1 4;11 8;1
+	PZ-09	<p>Unit load devices or freight containers containing dangerous goods described in 9.1.4, sub-paragraphs (a) to (d) of the IATA Dangerous Goods Regulations or lithium batteries prepared under Section II of Packing Instructions 965 to 970 will be accepted by advance arrangements and contract only in accordance with the current "Accreditation Freight Forwarder Programme" implemented by the TAM Dangerous Goods Department (see PZ-01).</p> <p>The shipper/freight forwarder must deliver a document certifying that:</p> <ul style="list-style-type: none"> — the shipment was prepared on secure premises and protected against unlawful interference during preparation, storage and transport; and — packages comply with all requirements of the IATA Dangerous Goods Regulations. 	7;1.4
+	PZ-10	<p>UN 3356 — Chemical oxygen generators transported to, from, through or within the United States must be placed in outer packaging that bears the additional tested specification mark of DOT 31FP indicating compliance with 49 CFR 173.168.</p>	4;7
P2 — AIRKENYA EXPRESS LTD			
	P2-01	<p>Dangerous goods, as defined by these Instructions, will not be accepted for carriage, with the exception of those articles and substances permitted for passengers and crew and UN 1845 — Carbon dioxide, solid (dry ice) when used as a refrigerant for non-dangerous goods.</p>	8;1

QF — QANTAS AIRWAYS

≠	QF-01	Not used.	
≠	QF-02	Division 4.1 — Flammable solids. Passengers and crew are not permitted to bring book matches onto aircraft for personal use. Book matches are only allowed as correctly packed and declared dangerous goods consignments.	8;1
+	QF-03	Operator approval is required for the carriage of all new and used internal combustion engines (see 2.3.5.15 of the IATA Dangerous Goods Regulations).	8;1
+	QF-04	Oxygen or air, gaseous cylinders required for medical use are only accepted for transport in or as carry-on baggage (see 2.3.4.1 of the IATA Dangerous Goods Regulations).	8;1

QK — JAZZ AVIATION LP

	QK-01	When a shipper's declaration is required for interline shipments, three (3) original copies must be provided with each shipment at the origin location.	5;4
	QK-02	The shipper must provide a 24-hour emergency telephone number of a person/agency who is knowledgeable of the hazards, characteristics and actions to be taken in the case of an accident or incident concerning each of the dangerous goods being transported. This telephone number, including the country and area code, preceded by the words "Emergency Contact" or "24-hour number" must be inserted on the shipper's declaration for dangerous goods, preferably in the "Handling Information" box, e.g. "Emergency Contact +1 514-123-4567".	5;4
		A 24-hour emergency telephone number is not required for shipments that do not require a shipper's declaration for dangerous goods.	
	QK-03	Salvage packaging will not be accepted for carriage.	4;1 5;1 5;2 6;2 6;4
	QK-04	Aircraft engines shipped under Special Provision A70 must be tendered with an original copy of the purged certificate and signed by the company that performed the maintenance or overhaul.	3;3 4;11
	QK-05	Internal combustion engines, being shipped either separately or incorporated into a machine or other apparatus, the fuel tank or fuel system of which contains or has contained fuel, must be classified as Engine, internal combustion, flammable liquid powered, UN 3166, Class 9 (including but not limited to chainsaws, lawnmowers, generators, outboard motors, etc.).	2;9 4;11
	QK-06	The number of packages of lithium batteries shipped in accordance with Section II of Packing Instructions 965 to 970 must be indicated on the air waybill.	4;11 5;4

>

QR — QATAR AIRWAYS

	QR-01	UN 1845 — Carbon dioxide, solid (dry ice) is restricted as follows:	Table 3-1
		— Maximum of 200 kg per aircraft hold (aft and bulk holds are considered as one hold) on all aircraft types except B777F.	
		— B777F-400 kg in lower deck (total in FWD + AFT + Bulk). Total dry ice quantity in lower deck and main deck must not exceed 1 000 kg.	
≠	QR-02	Dangerous goods are not permitted in the following:	1;2;3
		— airmail, including those items permitted by 2.4.2 of the IATA Dangerous Goods Regulations; and	
		— Qatar Airways express cargo product "courier baggage voucher (CBV)".	

	QR-03	The shipper must provide a 24-hour emergency telephone number of a person/agency who is knowledgeable of the hazards, characteristics and actions to be taken during an emergency concerning each of the dangerous goods being transported. This telephone number, including the country and area code, preceded by the words "Emergency contact" must be inserted on the shipper's declaration for dangerous goods (DGD) in the "Handling information" box.	
≠	QR-04	The following will not be accepted for carriage on Qatar Airways passenger flights: <ul style="list-style-type: none"> — UN 3091 — Lithium metal batteries contained in equipment; — UN 3091 — Lithium metal batteries packed with equipment. 	4;11
	QR-05	Class 8 — Corrosives. The following corrosives will not be accepted on Qatar Airways passenger and cargo aircraft: <ul style="list-style-type: none"> — UN 2803 — Gallium — UN 2809 — Mercury — UN 3506 — Mercury contained in manufactured articles 	2;8 Table 3-1
+	QR-06	Vehicles shipped in accordance with Packing Instruction 950 must have the fuel tank drained of fuel as far as practicable. If any fuel remains in the tank, it must not exceed one-eighth of the total tank capacity. Any additional fuel tanks must remain empty.	4;11
≠	QT — TAMPA CARGO		
	QT-01	Wheelchairs with spillable or wet batteries will be accepted only when the battery has been removed from the wheelchair and packaged according to paragraphs 2.3.2.3 and 9.3.14 of the IATA Dangerous Goods Regulations.	8;1
	QT-02	Oxygen, compressed, UN 1072 for medical use during flight, will not be accepted for carriage.	8;1
	QT-03	Dangerous goods in airmail will not be accepted for carriage.	1;2.3
	QT-04	Fissile radioactive material will not be accepted for carriage. (See 10.5.13 of the IATA Dangerous Goods Regulations.)	2;7
	QT-05	Radioactive material will only be accepted for transport when the radioactive material is intended for diagnostic purposes, medical treatment, industrial or research.	2;7 5;1
	QT-06	Mercury — UN 2809 will be accepted for carriage provided the following conditions are complied with: <ul style="list-style-type: none"> — only combination packagings will be accepted; — outer packagings must have a strong inner lining or leak-proof bags, puncture-resistant material, impervious to mercury and must meet the performance standards of Packing Group I; and — must be overpacked with a plastic box. 	Table 3-1 4;1
	QT-07	Arrangement with the airline is necessary for packages that contain dry ice.	Table 3-1 4;11 5;1 7;2
	QT-08	Spanish must be used in addition to English for all markings and dangerous goods documentation for domestic and international transport from Colombia.	5;2 5;3 5;4
	QY — EUROPEAN AIR TRANSPORT LEIPZIG GMBH — DHL		
	QY-01	Dangerous goods shipments transported by European Air Transport Leipzig GmbH (EAT) will only be accepted by advance arrangements with, and approval by, the Regional Restricted Commodities Group — DHL Express Europe Headquarters before presenting for transport.	
		Regional Restricted Commodities Group — DHL Express Europe Headquarters Telephone: +49 (0) 341 4499 4949 Facsimile: +49 (0) 4499 88 4982 Email: rcgalert@dhl.com	

QY-02	The waybill for dangerous goods in “Excepted Quantities” must show the applicable UN number in addition to the requirements of 2.6.8.2.	3;5
QY-03	All lithium batteries, including refurbished, prepared under Section II of Packing Instructions 965 to 970 will only be accepted for carriage with the approval of the Regional/Global Restricted Commodities Group — DHL Express Europe Headquarters.	4;11
QY-04	It is forbidden to carry weapons, munitions of war or parts of them, except with the express exemption of the national authorities. In this case, they must be carried in the aircraft in a place which is inaccessible to passengers during flight and, in the case of firearms, uncharged. Such items can only be accepted by advance arrangements with, and approval by, the Regional Restricted Commodities Group — DHL Express Europe Headquarters.	2;1 Table 3-1 7;2
≠ QY-05	Dangerous goods shipped under Special Provision A88 or A99 will only be accepted by advance arrangements and approval by the DHL Regional Restricted Commodities Group and European Air Transport Leipzig GmbH (EAT). The request for transport is required to be submitted to Global Restricted Commodities Group at least seven working days prior to planned transport and must contain the following information: <ul style="list-style-type: none"> — a copy of the air waybill including the shippers name, air waybill number, gross weight, origin, destination; — a copy of the document of approval from the appropriate authority of the State of Origin and other approvals as applicable; and — the complete planned routing including any transit stations. 	3;3
QY-06	Radioactive and fissile wastes will not be accepted for carriage.	2;7 Table 3-1
QY-07	Not used.	
QY-08	Handwritten shipper’s declarations will not be accepted. The following fields on the shipper’s declaration must be typed or computer generated: <p>UN or ID number including the prefix, proper shipping name, hazard class or division, subsidiary risk or division(s), packing group, packaging type, packing instruction, authorization and emergency telephone number.</p> <p><i>Note.— The technical name, when required, may be handwritten.</i></p> <p>For radioactive shipments, in addition to the items listed above, the following must also be typed or computer generated:</p> <p>Radionuclide, special form or physical and chemical form. All other entries may be handwritten.</p> <p>Handwritten alterations/amendments to an entry required to be typed per QY-08 are acceptable if each alteration/amendment is legible and signed with the same signature used to sign the shipper’s declaration.</p>	5;4
QY-09	The shipper must provide a 24-hour emergency telephone number of a person/agency who is knowledgeable of the hazards, characteristics and actions to be taken in the case of an accident or incident concerning each of the dangerous goods being transported. This telephone number, including the country and area code, preceded by the words “Emergency contact” or “24-hour number”, must be inserted on the DGD, preferably in the “Handling information” box. <p>A 24-hour emergency telephone number is not required for shipments that do not require a shipper’s declaration for dangerous goods.</p>	5;4
RJ — ROYAL JORDANIAN		
RJ-01	Advance arrangements must be made for all shipments of dangerous goods as defined in these Instructions.	
RJ-02	Dangerous goods in consolidations are accepted provided they are: <ul style="list-style-type: none"> — consolidations with only one house air waybill; or — consolidations with more than one house air waybill, only in case of an identical shipper; or 	7;1

- consolidations containing UN 1845, Carbon dioxide, solid (dry ice) when used as a refrigerant.

RO — TAROM

- | | | |
|---------|---|--------|
| RO-01 | Class 7 — Radioactive material of any kind will not be accepted for carriage. | |
| + RO-02 | Shipments of the following dangerous goods will not be accepted for transport on ATR aircraft: | Part 2 |
| | <ul style="list-style-type: none"> — Division 2.1 — Flammable gases; — Division 2.2 — Non-flammable, non-toxic gases except: <ul style="list-style-type: none"> — foodstuffs, including carbonated beverages (except UN 1950); — balls intended for use in sports; — tyres in accordance with Special Provision A59; — light bulbs, provided they are packaged so that the projectile effects of any rupture of the bulb will be contained within the package; and — empty receptacles for non-toxic and non-flammable gas; — Division 2.3 — Toxic gases; — Division 4.1 — Metal powders; — Division 5.2 — Organic peroxides; — Division 6.1 — Toxic substances; — Division 6.2 — Infectious substances included in Category A; and — Class 8 — Corrosive substances assigned to Packing Group I or II; | |
| + RO-03 | Shipments of the following dangerous goods will only be accepted for transport on ATR aircraft with the airline's approval: | |
| | <ul style="list-style-type: none"> — Division 1.4S — Explosives — Class 3 — Flammable liquids — Division 4.1 — Flammable solids — Division 4.2 — Substances liable to spontaneous combustion — Division 4.3 — Substances which, in contact with water, emit flammable gases (dangerous when wet) — Division 5.1 — Oxidizing substances | |

Application for approval can be made via email at sales.cargo@tarom.ro or mktng.cgo@tarom.ro.

- | | | |
|------------------------------|---|---------------------------------|
| + RS — SKY REGIONAL AIRLINES | | |
| RS-01 | When a shipper's declaration is required for interline shipments, three (3) original copies must be provided with each shipment at the origin location. | 5;4 |
| RS-02 | The shipper must provide a 24-hour emergency telephone number of a person/agency who is knowledgeable of the hazards, characteristics and actions to be taken in the case of an accident or incident concerning each of the dangerous goods being transported. This telephone number, including the country and area code, preceded by the words "Emergency Contact" or "24-hour number" must be inserted on the shipper's declaration for dangerous goods, preferably in the "Handling Information" box, e.g. "Emergency Contact +1 514-123-4567". | 5;4 |
| | A 24-hour emergency telephone number is not required for shipments that do not require a shipper's declaration for dangerous goods. | |
| RS-03 | Salvage packaging will not be accepted for carriage. | 4;1
5;1
5;2
6;2
6;4 |
| RS-04 | Aircraft engines shipped under Special Provision A70 must be tendered with an original copy of the purged certificate and signed by the company that performed the maintenance or overhaul. | 3;3
4;11 |
| RS-05 | Internal combustion engines, being shipped either separately or incorporated into a machine or other apparatus, the fuel tank or fuel system of which contains or has contained fuel, must be classified as Engines, internal combustion, flammable liquid powered, UN 3166, Class 9 (including but not limited to chainsaws, lawnmowers, generators, outboard motors, etc.). | 2;9
4;11 |

	RS-06	The number of packages of lithium batteries shipped in accordance with Section II of Packing Instructions 965 to 970 must be indicated on the air waybill.	4;11 5;4
+		RU — AIR BRIDGE CARGO AIRLINE	
	RU-01	Packages of dangerous goods with a primary risk of Class 8 labelled "Cargo Aircraft Only" are forbidden for transport on the lower deck of the aircraft on all airline flights.	
	RU-02	UN 3090 — Lithium metal batteries transported under Section IA of Packing Instruction 968 and UN 3091 — Lithium metal batteries contained in or packed with equipment transported under Section I of Packing Instructions 969 and 970 are accepted for transport with the prior confirmation of the airline only. The required information can be requested via email at dq@airbridgecargo.com .	
		RV — AIR CANADA ROUGE	
	RV-01	When a shipper's declaration is required for interline shipments, three (3) original copies must be provided with each shipment at the origin location.	5;4
	RV-02	The shipper must provide a 24-hour emergency telephone number of a person/agency who is knowledgeable of the hazards, characteristics and actions to be taken in the case of an accident or incident concerning each of the dangerous goods being transported. This telephone number, including the country and area code, preceded by the words "Emergency Contact" or "24-hour number" must be inserted on the shipper's declaration for dangerous goods, preferably in the "Handling Information" box, e.g. "Emergency Contact +1 514-123-4567". A 24-hour emergency telephone number is not required for shipments that do not require a shipper's declaration for dangerous goods.	5;4
	RV-03	Salvage packaging will not be accepted for carriage.	4;1 5;1 5;2 6;2 6;4
	RV-04	Aircraft engines shipped under Special Provision A70 must be tendered with an original copy of the purged certificate and signed by the company that performed the maintenance or overhaul.	3;3 4;11
	RV-05	Internal combustion engines, being shipped either separately or incorporated into a machine or other apparatus, the fuel tank or fuel system of which contains or has contained fuel, must be classified as Engine, internal combustion, flammable liquid powered, UN 3166, Class 9 (including but not limited to chainsaws, lawnmowers, generators, outboard motors, etc.).	2;9 4;11
	RV-06	The number of packages of lithium batteries shipped in accordance with Section II of Packing Instructions 965 to 970 must be indicated on the air waybill.	4;11 5;4
>			
+		SB — AIRCALIN	
	SB-01	Internal combustion or fuel cell engines carried separately or incorporated into a machine or other apparatus carried as checked baggage by passengers or crew members are not permitted whether they are used or new. This includes but is not limited to brush cutters, chainsaws, lawnmowers and weed eaters. This variation applies to all flights operated by Aircalin.	8;1
		SJ — SOUTHERN AIR TRANSPORT	
	SJ-01	Prior approval is required for shipments containing mercury.	

≠	SK — SAS — SCANDINAVIAN AIRLINES SYSTEM	
	SK-01 Single packagings containing liquids are not accepted for carriage on SAS aircraft unless overpacked with, for example, a suitably sized pallet to protect the base of the packaging.	4;1
>		
	SN — BRUSSELS AIRLINES	
	SN-01 Used camping stoves (fuel or gas) will not be accepted for carriage in baggage, even if thoroughly cleaned.	8;1
	SN-02 Small gaseous oxygen or air cylinders required for medical use will only be accepted empty as checked baggage.	8;1
	SN-03 Exempt patient specimens as defined in paragraph 3.6.2.2.3.6 of the IATA Dangerous Goods Regulations will only be accepted on Brussels Airlines flights after written approval from the Brussels Airlines Dangerous Goods Department:	2;6.3.2.3.6
	Brussels Airlines DG Department Brussels Airport b-house Building 26 box 1.7 1930 Zaventem BELGIUM Email: dqdepartment@brusselsairlines.com	
	SQ — SINGAPORE AIRLINES/SINGAPORE AIRLINES CARGO	
	SQ-01 Only explosives of Division 1.4S packed for "passenger and cargo aircraft" or "cargo aircraft only" will be accepted.	2;1 Table 3-1 7;2
	SQ-02 Items with a primary or subsidiary risk of Division 2.1 and Class 4, when packed for "passenger and cargo aircraft", must be loaded in the lower deck.	2;1 Table 3-1 7;2
	SQ-03 Items with a primary or subsidiary risk of Division 2.1 and Class 4, when packed for cargo aircraft only, will not be accepted.	2;4 Table 3-1
≠	SQ-04 Class 7 — Fissile material (including fissile-excepted) will not be accepted.	2;7 Table 3-1
≠	SQ-05 Only Division 6.2 and/or Class 9 and/or dangerous goods in limited or excepted quantities and/or aircraft batteries transported as items of replacement will be uplifted into/over the United States in a passenger aircraft. For uplift in a cargo aircraft, please refer to US 13.	Table 3-1
	SQ-06 Oxygen generators, chemical (UN 3356) will not be accepted on any aircraft.	2;5 Table 3-1
≠	SQ-07 Lithium metal batteries (UN 3090). Lithium metal cells and batteries are prohibited from carriage as cargo on Singapore Airlines aircraft. This applies to Section IA, Section IB and Section II of Packing Instruction 968. In addition, lithium metal cells and batteries (UN 3091) prepared in accordance with Section I of Packing Instruction 969 or Packing Instruction 970 are prohibited for carriage as cargo on Singapore Airlines passenger aircraft.	Table 3-1 4;11 8;1
	This prohibition does not apply to:	
	<ul style="list-style-type: none"> — lithium metal cells and batteries packed with or contained in equipment (UN 3091) in accordance with Section II of Packing Instruction 969 or 970 on passenger aircraft; — lithium ion cells and batteries (UN 3480 and UN 3481) in accordance with Packing Instruction 965, 966 or 967; or — lithium batteries (rechargeable and non-rechargeable) covered by the Provisions for Dangerous Goods Carried by Passengers or Crew. (See 2.3.2 to 2.3.5 and Table 2.3.A of the IATA Dangerous Goods Regulations and Part 8 of these Instructions.) 	

	SQ-08	The shipper must provide a 24-hour emergency telephone number of a person/agency who is knowledgeable of the hazards, characteristics and actions to be taken in the case of an accident or incident concerning each of the dangerous goods being transported. This telephone number, including the country and area code, preceded by the words, e.g. "Emergency contact" or "24-hour number", must be inserted on the shipper's declaration for dangerous goods (DGD), preferably in the "Handling information" box, e.g. "Emergency contact +47 67 50 00 00". A 24-hour emergency telephone number is not required for shipments that do not require a DGD.	5;4
	SQ-09	Dangerous goods shipments from other carriers will not be accepted.	7;1
	SQ-10	Carriage of Category B infectious substances, UN 3373 (Biological substance, Category B) is subject to specific requirements. Shippers wishing to consign UN 3373 are requested to contact the Singapore Airlines cargo office for these requirements.	2;6 Table 3-1
+	SQ-11	Oxygen or air, gaseous cylinders required for medical or other use are not permitted in passengers' checked or carry-on baggage and on one's person. Should a passenger require supplementary oxygen, a prior request must be made to Singapore Airlines (see 2.3.4.1 of the IATA Dangerous Goods Regulations and Table 8-1, Item 1) of these Instructions).	8;1
	SS — CORSAIR		
	SS-01	Class 7 — Radioactive material, including all categories of excepted packages, will not be accepted for transport.	1;6 2;7 Table 3-1 3;5
	SV — SAUDI ARABIAN AIRLINES		
	SV-01	Dangerous goods in excepted quantities will not be accepted.	3;5
	SV-02	Not used.	
	SV-03	Dangerous goods in consolidations will not be accepted for carriage.	7;1
	SV-04	Package orientation (This Way Up) labels must be used on any combination and single package containing liquid dangerous goods, excluding infectious substances, if primary receptacles contain less than 50 mL, and radioactive material.	5;3
	SV-05	Maximum net weight of carbon dioxide, solid (dry ice) accepted for loading is 200 kg per lower hold of a passenger aircraft.	7;2
	SV-06	Salvage packagings will not be accepted for carriage without prior approval from the Cargo Operations Control Centre.	4;1
	SV-07	Steel drums (1A1) with plastic pullout spout or cap will not be accepted for carriage on any aircraft.	6;1
	SV-08	Not used.	
	SV-09	Class 7, fissile radioactive material will not be accepted for carriage (see 10.5 of the IATA Dangerous Goods Regulations).	
	SV-10	Battery-powered wheelchairs or mobility aids with spillable batteries will not be accepted on SV aircraft as checked baggage (see 2.3.2.3 and 9.3.16 of the IATA Dangerous Goods Regulations).	Table 8-1
	SV-11	Fuel containers for camping stoves that have contained a flammable liquid fuel will not be accepted for carriage as checked baggage.	8;1
	SV-12	All shipments of infectious substances, patient specimens, diagnostic specimens, clinical specimens, biological substances (human or animal), whether subject to regulation or exempt from regulation, must be manifested as cargo and will not be permitted in the aircraft cabin.	2;7 7;2
	SV-13	The shipper must provide a 24-hour emergency telephone number of a person/agency who is knowledgeable of the hazards, characteristics and actions to be taken in the case of an accident or incident concerning each of the dangerous goods being transported. This telephone number, including the country and area code, preceded by the words "Emergency contact" or "24-hour number", must be inserted on the shipper's declaration for dangerous goods (DGD), preferably in the "Handling information" box, e.g. "Emergency contact +47 67 50 00 00". (See 8.1.6.11 and 10.8.3.11 of the IATA Dangerous Goods Regulations.)	5;4

A 24-hour emergency telephone number is not required for shipments that do not require a DGD.

SW — AIR NAMIBIA

SW-01	Dangerous goods, as defined in these Instructions, will not be accepted for carriage on the Beechcraft B1900 aircraft.	Table 3-1 7;2
SW-02	Dangerous goods in limited quantities (“Y” packing instructions) will not be accepted for carriage. (Exception: ID 8000 — Consumer commodity will be accepted.) (See 3;4 of these Instructions, 2.7 of the IATA Dangerous Goods Regulations and all “Y” packing instructions.)	3;4
SW-03	Dangerous goods in consolidations will not be accepted for carriage, except for: <ul style="list-style-type: none"> — consolidations containing UN 1845, Carbon dioxide, solid (dry ice) when used as a refrigerant; — consolidations with only one house air waybill; — for a single shipper, consolidations with more than one house air waybill. 	7;1

S7 — JSC SIBERIA AIRLINES

S7-01	Shipment of dangerous goods transported by Siberia Airlines will only be acceptable after getting advance approval from Siberia Airlines. Requests for dangerous goods shipments must be made on the special form of approval (form is provided by request) and sent to the following email address: cgo@s7.ru . The form of approval is to be attached to the set of accompanying documents and forwarded on board to the crew by the handling company at the airport of departure.	5;4 7;4
S7-02	Patient specimens will only be accepted if assigned to UN 2814 or UN 2900 or UN 3373 as appropriate. Biological substance, Category B — UN 3373 may only be accepted for carriage under necessary requirements and after a prior Siberia Airlines written approval has been granted.	2;6 Table 3-1
S7-03	The shipper must provide a 24-hour emergency telephone number of a person/agency who is knowledgeable of the hazards, characteristics and actions to be taken in case of an accident or incident concerning each of the dangerous goods being transported. This telephone number, including the country and area code, preceded by the words “Emergency Contact” or “24-hour number” must be inserted on the shipper’s declaration for dangerous goods in the “Additional Handling Information” box, e.g. “Emergency Contact +7 495 123 45 78”.	5;4

+

TA — TACA INTERNATIONAL

TA-01	Wheelchairs with spillable or wet batteries will be accepted only when the battery has been removed from the wheelchair and packaged according to paragraphs 2.3.2.3 and 9.3.14 of the IATA Dangerous Goods Regulations.	8;1
TA-02	Oxygen, compressed, UN 1072 for medical use during flight, will not be accepted for carriage.	8;1
TA-03	Dangerous goods in airmail will not be accepted for carriage.	1;2,3
TA-04	Fissile radioactive material will not be accepted for carriage. (See 10.5.13 of the IATA Dangerous Goods Regulations.)	2;7
TA-05	Radioactive material will only be accepted for transport when the radioactive material is intended for diagnostic purposes, medical treatment, industrial or research.	2;7 5;1
TA-06	Mercury — UN 2809 will be accepted for transport provided the following conditions are complied with: <ul style="list-style-type: none"> — only combination packagings will be accepted; — outer packagings must have a strong inner lining or leak-proof bags, puncture-resistant material, impervious to mercury; and — must be overpacked with a plastic box. 	Table 3-1 4;1

TA-07	Arrangement with the airline is necessary for packages that contain dry ice.	Table 3-1 4;11 5;1 7;2
TA-08	Spanish must be used in addition to English for all markings and dangerous goods documentation for domestic and international transport from El Salvador.	5;2 5;3 5;4

TG — THAI AIRWAYS INTERNATIONAL

TG-01	Dangerous goods in excepted quantities will not be accepted.	3;5
TG-02	All dangerous goods packed in single packaging UN specification 1A1 or 1A2 steel drums or composite packaging plastic receptacle with outer steel drum (6HA1) are not acceptable for carriage unless overpacked with a suitably sized wooden pallet to protect the top and base of the packaging.	4;1 6;1
TG-03	Class 1 — All kinds of explosives will not be accepted for carriage, except substances and articles of Division 1.4S which fall under shipment of Thai urgent aircraft spare parts carried to/from home base or line stations or AOG and supplies.	2;1 Table 3-1
TG-04	Only radioactive material with a maximum transport index not exceeding 3.0 which is intended for medical purposes will be accepted for carriage.	Table 3-1 5;1
TG-05	Radioactive material packed in Type B(U), Type B(M) packages and SCO or LSA packed in industrial packages will not be accepted for carriage.	2;7 Table 3-1 4;9
TG-06	The shipper must provide a 24-hour emergency telephone number of a person/agency who is knowledgeable of the hazards, characteristics and actions to be taken in case of an accident or incident concerning (each of) the dangerous goods being transported. This telephone number, including country and area code, preceded by the words "Emergency contact" or "24-hour number" must be inserted on the shipper's declaration for dangerous goods (DGD) preferably in the "Handling information" box, e.g. "Emergency contact +47 67 50 00 00".	5;4
TG-07	Shipments under State approval in accordance with Special Provision A1 or A2 will not be accepted.	3;3

TK — TURKISH AIRLINES

TK-01	Not used.	
TK-02	Emergency response: The shipper must provide a 24-hour emergency telephone number of a person/agency, who is knowledgeable of the hazards, characteristics and actions to be taken in case of an accident or incident concerning each of the dangerous goods being transported. This telephone number, including the country and area code, preceded by the words "Emergency contact" or "24-hour number" must be inserted in the "Handling information" box of the DGD and also outside of the package. A 24-hour emergency telephone number is not required for shipments that do not require a shipper's declaration for dangerous goods.	5;4
TK-03	Dangerous goods in consolidations will not be accepted for carriage except for the following shipments: — consolidated shipments/consolidations containing carbon dioxide, solid (dry ice) when used as a refrigerant; — one master air waybill with one house air waybill; — one master air waybill with more than one house air waybill, which have the same shipper and different consignees.	7;1
TK-04	Booking and confirmation are required for all dangerous goods shipments as defined in the IATA Dangerous Goods Regulations. Turkish Cargo Reservation Department Tel: +90 212 465 22 22 Fax: +90 212 465 24 78 SITA: ISTFCTK	

	TK-05	Not used.	
	TK-06	All dangerous goods classes and radioactive material will not be accepted in airmail.	1;2,3 2;7
	TK-07	Infected animals, dead or alive, will not be accepted for carriage.	2;6 Table 3-1
>			
		TN — AIR TAHITI NUI	
	TN-01	Not used.	
	TN-02	Shipments under State approval in accordance with Special Provision A1 or A2 are not accepted.	3;3
	TN-03	Cylinders of oxygen, compressed (UN 1072), either as cargo or (for medical use only) as baggage, are accepted only if contained in a fire-resistant outer packaging meeting ATA 300 Type I shipping container specification or equivalent.	
	TN-04	Dangerous goods in limited quantities ("Y" packing instructions) will not be accepted for carriage, except for dangerous goods classified as "Consumer commodity".	3;4
	TN-05	Category B infectious substances and biological products listed under UN 3373, Packing Instruction 650, may only be transported when the following information is indicated on the air waybill:	2;6 5;4
		<ul style="list-style-type: none"> — the proper shipping name: "Biological substance, Category B"; — the UN number "UN 3373"; — the division number, 6.2; — the number of packages; and — the net quantity of infectious substances in each package. 	
		The name, address and a telephone number of a person responsible must be indicated on the air waybill and on the package(s).	
+		TS — AIR TRANSAT	
	TS-01	Air Transat Cargo will only accept the following classes of dangerous goods for carriage as cargo:	Part 2
		<ul style="list-style-type: none"> — Class 2 — Gases; — Class 3 — Flammable liquids; — Class 8 — Corrosives; and — Class 9 — Miscellaneous dangerous goods. 	
	TS-02	In addition to the limits of TS-01, UN 3373 — Biological substance, Category B will not be accepted.	2;6
	TS-03	The following dangerous goods will not be accepted as cargo:	Table 3-1 2;9
		<ul style="list-style-type: none"> — UN 3091 — Lithium metal batteries packed with equipment (Packing Instruction 969, Sections I and II); — UN 3091 — Lithium metal batteries contained in equipment (Packing Instruction 970, Sections I and II); and — UN 3480 — Lithium ion batteries (Packing Instruction 965, Sections IA, IB and II). 	
	TS-04	Battery-powered wheelchairs or other mobility devices with spillable batteries will not be accepted.	8;1
		<i>Note.— Battery-powered wheelchairs and mobility aids with non-spillable or lithium batteries are acceptable.</i>	
		TU — TUNIS AIR	
	TU-01	Class 1 — Explosives are not acceptable for carriage with the exception of those in Division 1.4S.	2;1 Table 3-1
	TU-02	Division 2.1 — Flammable gases are not acceptable for carriage with the exception of Aerosols, flammable, UN 1950.	2;2 Table 3-1

TU-03	Division 2.3 — Toxic gases are not acceptable for carriage.	2;2 Table 3-1
TU-04	The following substances or articles or substances are not acceptable for carriage (see packing instructions [–] listed after each substance): UN 1003 — Air, refrigerated liquid [202] UN 1043 — Fertilizer ammoniating solution [200] UN 1724 — Allyltrichlorosilane, stabilized [876] UN 1732 — Antimony pentafluoride [855] UN 1747 — Butyltrichlorosilane [876] UN 1753 — Chlorophenyltrichlorosilane [876] UN 1762 — Cyclohexenyltrichlorosilane [876] UN 1763 — Cyclohexyltrichlorosilane [876] UN 1769 — Diphenyldichlorosilane [876] UN 1771 — Dodecyltrichlorosilane [876] UN 1781 — Hexadecyltrichlorosilane [876] UN 1784 — Hexyltrichlorosilane [876] UN 1792 — Iodine monochloride [863] UN 1796 — Nitrating acid mixture [854, 855] UN 1799 — Nonyltrichlorosilane [876] UN 1800 — Octadecyltrichlorosilane [876] UN 1801 — Octyltrichlorosilane [876] UN 1802 — Perchloric acid [855] UN 1806 — Phosphorus pentachloride [863] UN 1808 — Phosphorus tribromide [855] UN 1809 — Phosphorus trichloride [–] UN 1810 — Phosphorus oxychloride [–] UN 1816 — Propyltrichlorosilane [876] UN 1826 — Nitrating acid mixtures, spent [854, 855] UN 1832 — Sulphuric acid, spent [855] UN 1837 — Thiophosphoryl chloride [855] UN 1906 — Sludge acid [855] UN 1912 — Methyl chloride and methylene chloride mixture [200] UN 1939 — Phosphorus oxybromide [863] UN 2028 — Bombs, smoke, non-explosive [866] UN 2031 — Nitric acid [851, 854, Y840, 855] UN 2073 — Ammonia solutions [200] UN 2435 — Ethylphenyldichlorosilane [876] UN 2691 — Phosphorus pentabromide [863] UN 2799 — Phenyl phosphorus thiodichloride [855]. The following articles and substances in Class 9 are not acceptable for carriage: UN 2211 — Polymeric beads, expandable [957] UN 2590 — White asbestos [958].	Table 3-1
TU-05	Class 3 — Flammable liquids (Packing Group I) are not acceptable for carriage.	2;3 Table 3-1
TU-06	Class 4 substances (Packing Group I) are not acceptable for carriage.	2;4 Table 3-1
TU-07	The following articles and substances in Class 4 are not acceptable for carriage (see packing instructions [–] listed after each substance): UN 1390 — Alkali metal amides [483, Y475, 489] UN 1415 — Lithium [487] UN 1420 — Potassium metal alloys, liquid [480] UN 1428 — Sodium [487] UN 1868 — Decaborane [448] UN 2257 — Potassium [487] UN 2813 — Water-reactive solid, n.o.s. [Y475, Y477, 484, 486, 488, 490, 491] UN 3404 — Potassium sodium alloys, solid [487].	2;4 Table 3-1
TU-08	Class 5 substances (Packing Groups II and III) are only acceptable for carriage with prior arrangements. Class 5 substances (Packing Group I) are not acceptable for carriage.	2;5 Table 3-1
TU-09	Division 6.1 substances (Packing Group I) are not acceptable for carriage.	2;6 Table 3-1

TU-10	Shippers of radioactive material must submit with the shipper's declaration for dangerous goods a certificate from the competent authority of the State of Origin specifying that the shipment complies with the Instructions. Type B(M) packages of radioactive material are not acceptable for carriage.	2;7 Table 3-1 5;4
TU-11	Class 8 — Corrosive materials (Packing Group I) are not acceptable for carriage.	2;8 Table 3-1
TU-12	The following substances in Class 8 are not acceptable for carriage (see packing instructions [–] listed after each substance): UN 1766 — Dichlorophenytrichlorosilane [876] UN 1767 — Diethyldichlorosilane [876] UN 2798 — Phenyl phosphorus dichloride [855].	2;8 Table 3-1
TX — AIR CARAIBES		
TX-01	Only radioactive material Category I-White (IMP code RRW (see B.2.2.4 of the IATA Dangerous Goods Regulations)) where the maximum radiation level at any point on any external surface of a package or overpack does not exceed 5 µSv/h is accepted for transport.	2;7 Table 3-1 5;1
+ TZ — SCOOT AIRLINES		
TZ-01	Class 7 — Fissile Material will not be accepted.	2;7
TZ-02	UN 3356 — Oxygen generator, chemical, will not be accepted for carriage.	
TZ-03	The shipper must provide a 24-hour emergency telephone number of a person/agency who is knowledgeable of the hazards, characteristics and actions to be taken in the case of an accident or incident concerning each of the dangerous goods being transported. This telephone number, including the country and area code, preceded by the words "Emergency contact" or "24-hour number", must be inserted on the shipper's declaration for dangerous goods (DGD), preferably in the "Handling information" box, e.g. "Emergency contact +47 67 50 00 00". (See 8.1.6.11 and 10.8.3.11 of the IATA Dangerous Goods Regulations.) A 24-hour emergency telephone number is not required for shipments that do not require a DGD.	5;4
TZ-04	Dangerous goods shipments will only be accepted from SIA, SIA Cargo and Silkair.	
TZ-05	Carriage of UN 3373 — Biological substance, Category B infectious substances of subject to specific requirements. Shippers wishing to consign UN 3373 are requested to contact the Scoot office for these requirements.	2;6
TZ-06	Lithium metal cells and batteries contained in or packed with equipment (UN 3091) prepared in accordance with Section I of Packing Instruction 969 and Packing Instruction 970 are prohibited for carriage as cargo. This prohibition does not apply to: — lithium metal cells or batteries packed with or contained in equipment (UN 3091) in accordance with Section II of Packing Instructions 969 and 970; — lithium ion cells and batteries (UN 3480 and UN 3481) in accordance with Packing Instructions 965, 966 and 967; or — lithium batteries (rechargeable and non-rechargeable) covered under the provisions for dangerous goods carried by passengers or crew (see 2.3.2 to 2.3.5 and Table 2.3.A of the IATA Dangerous Goods Regulations).	Table 3-1 4;11
+ T0 — TACA PERU		
T0-01	Wheelchairs with spillable or wet batteries will be accepted only when the battery has been removed from the wheelchair and packaged according to paragraphs 2.3.2.3 and 9.3.14 of the IATA Dangerous Goods Regulations.	8;1

	T0-02	Oxygen, compressed, UN 1072 for medical use during flight, will not be accepted for carriage.	8;1
	T0-03	Dangerous goods in airmail will not be accepted for carriage.	1;2.3
	T0-04	Fissile radioactive material will not be accepted for carriage. (See 10.5.13 of the IATA Dangerous Goods Regulations.)	2;7
	T0-05	Radioactive material will only be accepted for transport when the radioactive material is intended for diagnostic purposes, medical treatment, industrial or research.	2;7 5;1
	T0-06	Mercury — UN 2809 will be accepted for transport provided the following conditions are complied with: <ul style="list-style-type: none"> — only combination packagings will be accepted; — outer packagings must have a strong inner lining or leak-proof bags, puncture-resistant material, impervious to mercury; and — must be overpacked with a plastic box. 	Table 3-1 4;1
	T0-07	Arrangement with the airline is necessary for packages that contain dry ice.	Table 3-1 4;11 5;1 7;2
	T0-08	Spanish must be used in addition to English for all markings and dangerous goods documentation for domestic and international transport from Peru.	5;2 5;3 5;4
	UA — UNITED AIRLINES		
≠	UA-01	All liquid dangerous goods, in all classes and divisions must be packed in combination packagings. Single packagings are not allowed. <ul style="list-style-type: none"> — An overpack, by definition, is not a combination packaging. (See 5.0.1.5 and Appendix A of the IATA Dangerous Goods Regulations.) — Environmentally hazardous substances, liquid (UN 3082) in drums with a net quantity greater than 128 L (34 United States gallons) are excepted from this provided that they are securely banded to wooden skids. 	1;3 4;1
≠	UA-02	Division 6.1 toxic substances are only accepted: <ul style="list-style-type: none"> — when these shipments are Packing Group II or Packing Group III; — when there is no inhalation toxicity; and — when the shipper's declaration for the toxic materials contains a certifying statement that the shipment contains materials intended for use in, or incident to, medical purposes. <p>Limited quantities are subject to the same requirements.</p>	2;6 Table 3-1
	UA-03	The carriage of UN 1845 — Carbon dioxide, solid (dry ice) is limited by aircraft type and the weight of the dry ice must be provided at booking in order to determine whether aircraft limits would be exceeded. <p>United Express and regional partners are limited to:</p> <p>2.5 kg net weight per package 35 kg net weight per aircraft</p>	2;9 Table 3-1 5;3 7;2.11

UC — LAN CARGO

≠ UC-01 Dangerous goods offered for transport under an approval or an exemption as provided by 1.2.5 and 1.2.6 of the IATA Dangerous Goods Regulations and any other LAN Cargo conditions by pre-approval will be accepted only after prior review and approval of the LATAM Dangerous Goods Technical Committee. 1;1.1

In addition, UN 1040 and UN 2014, when shipped as excepted quantities in accordance with Special Provisions A131 and A75 respectively, also require prior review and approval of the LATAM Dangerous Goods Technical Committee.

An application for approval must be undertaken at least fifteen working days in advance of the scheduled date for the flight. The material safety data sheet (MSDS) or other documentation that covers the shipment must be attached. Applications should be addressed to:

LAN Cargo Dangerous Goods Department
 Telephone: +786-265-6150/+1 305-467-7429
 +56-2-677-4571/+56-2-25669366
 +1-305-772-2894
 Email: DangerousGoodsBoard@lan.com

UC-02 The shipper must provide a 24-hour emergency telephone number of a person/agency who is knowledgeable of the hazards, characteristics and actions to be taken in case of an accident or incident concerning each of the dangerous goods being transported. This telephone number, including the country and area code, preceded by the words "Emergency contact" or "24-hour number" must be inserted on the declaration for dangerous goods in the "Handling Information" box. (See 8.1.6.11 and 10.8.3.11 of the IATA Dangerous Goods Regulations.) Table 3-1
5;4

An emergency response telephone number is not required for:

- battery-powered equipment;
- battery-powered vehicle;
- flammable gas-powered vehicle;
- flammable liquid-powered vehicle;
- engine, internal combustion;
- dangerous goods in limited quantities as described in 3;4 of these Instructions (2.7 of the IATA Dangerous Goods Regulations);
- carbon dioxide, solid (dry ice);
- consumer commodity; and
- refrigerating machines.

UC-03 For toxic substances of Division 6.1 or Division 2.3, the following requirements must be complied with: 2;3
2;6
5;4
6;1

- a) Toxic substances of Division 6.1, Packing Group I, that are toxic by inhalation, will not be accepted for carriage unless a prior approval has been obtained (see LA-01).
- b) Toxic gases of Division 2.3 will not be accepted for carriage unless a prior approval has been obtained (see LA-01).
- c) When the substance to be carried has an inhalation, mist, powder or vapour hazard, the shipper's declaration must have the following endorsement in the "Additional handling information box": "Mist, powder or vapour inhalation hazard", as appropriate.

Note 1.— This requirement only applies to the primary risk.

Note 2.— Where the substance has more than one route of toxicity, the risk that determined the packing group must be used.

	<p>d) Solid toxic substances of any kind will not be accepted for carriage in bags 5H1, 5H2, 5H3, 5H4, 5L2, 5L3, 5M1 or 5M2 as single packagings unless contained in a strong hot sealed polyethylene bag at least 200 microns thick. If these types of packages are offered overpacked in a warehouse pallet, they will be accepted for carriage provided:</p> <ol style="list-style-type: none"> 1) the warehouse pallet is rigid and strong enough to support the weight assembled on it, without bending when picked up and transported by a forklift; 2) the surface of the warehouse pallet is continuous, soft and free of sharp protruding points which could pierce the bags; and 3) the warehouse pallet is provided with separation bars from the floor for the use of a forklift. 	
UC-04	<p>Infectious substances will be accepted under specific advance arrangements and the following requirements must be met:</p> <ol style="list-style-type: none"> a) The shipper must prove by a document such as a fax, telex, letter, etc., that the infectious substance can legally enter the State of Destination and that all the requirements of the States of Origin and Destination of the shipment have been complied with. b) The shipper must attach a certificate duly signed and issued by a medical, scientific or other similar professional which confirms the classification of these specimens in the following cases: <ul style="list-style-type: none"> — shipment of Biological substance, Category B; — shipment of any patient specimens prepared according to 3.6.2.2.3.6 of the IATA Dangerous Goods Regulations. c) Infected animals, dead (whole bodies) or alive will not be accepted for carriage. 	2;6.3.2.3.6 5;4
UC-05	Formaldehyde solutions containing less than 25% of formaldehyde must be shipped under UN 3334 — Aviation regulated liquid, n.o.s.*, Class 9, Packing Group III.	Table 3-1
UC-06	The marking required by 7.1.5 of the IATA Dangerous Goods Regulations and application of hazard and handling labels on packages containing dangerous goods must not be applied to the top or bottom of packages. These markings and labels must be applied to the sides of packages. This requirement does not apply to marking of the full name and address of the shipper and consignee.	5;2 5;3
UC-07	Fissile material as defined in 10.3.7 of the IATA Dangerous Goods Regulations will be accepted only with prior review and approval by the IATA Dangerous Goods Technical Committee (see LA-01).	1;6.1.5 2;7
+ UC-08	<p>UN 3090 — Lithium metal batteries and UN 3091 — Lithium metal batteries contained in or packed with equipment. Primary (non-rechargeable) lithium (metal) batteries and cells must be transported on cargo aircraft only (CAO).</p> <p>This prohibition does not apply to:</p> <ul style="list-style-type: none"> — lithium batteries (rechargeable and non-rechargeable) covered by the provisions for dangerous goods carried by passengers or crew. (See Table 2.3.A of the IATA Dangerous Goods Regulations.); — lithium metal batteries and cells contained in medical equipment being transported for humanitarian reasons; — lithium metal batteries and cells that are presented as COMAT of any air company of LATAM Airlines Group. 	Table 3-1 4;11 8;1

- + UC-09 Unit load devices or freight containers containing dangerous goods described in 9.1.4, sub-paragraphs (a) to (d) of the IATA Dangerous Goods Regulations or lithium batteries prepared under Section II of Packing Instructions 965 to 970 will be accepted by advance arrangements and contract only in accordance with the current "Accreditation Freight Forwarder Programme" implemented by the LAN Cargo Dangerous Goods Department (see UC-01). 7;1.4

The shipper/freight forwarder must deliver a document certifying that:

- the shipment was prepared on secure premises and protected against unlawful interference during preparation, storage and transport; and
- packages comply with all requirements of the IATA Dangerous Goods Regulations.

- + UC-10 UN 3356 — Chemical oxygen generators transported to, from, through or within the United States must be placed in outer packaging that bears the additional tested specification mark of DOT 31FP indicating compliance with 49 CFR 173.168. 4;7

UL — SRILANKAN AIRLINES

- UL-01 The shipper must provide a 24-hour emergency telephone number of a person/agency who is knowledgeable of the hazards, characteristics and actions to be taken in case of an accident or incident concerning each of the dangerous goods being transported. This telephone number, including the country and area code, preceded by the words "Emergency Contact" or "24-hour number" must be inserted on the shipper's declaration for dangerous goods, preferably in the "Handling Information" box. (See 5;4 of these Instructions and 8.1.6.11 and 10.8.3.11 of the IATA Dangerous Goods Regulations.) 5;4

This will be applied on shipments to, from or transiting through Sri Lanka. The 24-hour emergency telephone number is not required for shipments that do not require a shipper's declaration for dangerous goods.

Additional information or operator approval can be obtained from:

Cargo Duty Manager — Dangerous Goods
Srilankan Airlines
Cargo Centre
Bandaranike International Airport
Katunayake
Sri Lanka
Telephone: +94 1 9733 3269
 +94 1 9733 2455
Teletype: CMBDGUL
Facsimile: +94 1 9733 5288
Email: cargodq@srilankan.aero

- UL-02 Items listed in the IATA Dangerous Goods Regulations or these Instructions which are totally forbidden or forbidden on passenger aircraft will not be accepted for transportation. Table 3-1
- UL-03 Prior approval from the carrier is needed for shipments of explosives and weapons.
- UL-04 Dangerous goods in airmail will not be accepted for carriage. 1;2.3
- UL-05 A brief text in the English language indicating the nature of the risk involved must appear on all hazard labels. The text should appear prominently in English in the lower half of the label as described in 5;3.5 of these Instructions and 7.2.2.4 of the IATA Dangerous Goods Regulations. 5;2
5;3

Package and overpack markings required by these Instructions and the IATA Dangerous Goods Regulations must be completed in English in addition to the language which may be required by the State of Origin. (See 5;2.5 of these Instructions and Figure 7.3.A through Figure 7.3.V, Figure 7.4.A and 10.7.7 of the IATA Dangerous Goods Regulations.)

≠	<p>UL-06 Prior approval is required for shipments containing radioactive material. Information can be obtained from:</p> <p style="margin-left: 40px;">Atomic Energy Authority Head, Radiation Protection and Regulations No. 60/460, Baseline Road Orugodawatta Wellampitiya Sri Lanka Telephone: +94 11 2533427-8 or +94 11 2534209 or +94 718 111650 or +94 773 683940 Facsimile: +94 11 2533448 Email: anil@aea.gov.lk</p> <p>UL-07 Gaseous oxygen or air cylinders required for medical use will not be accepted for carriage. Contact carrier for more details.</p>	<p>2;7</p>
≠	<p>US — US AIRWAYS</p> <p>US-01 Substances with a primary or subsidiary risk of Division 6.1 will not be accepted for carriage.</p> <p>US-02 Hazardous waste in any form, as defined by any regulation, will not be accepted for carriage (see Packing Instruction 622 and 8.1.3.4 of the IATA Dangerous Goods Regulations).</p> <p>US-03 Mercurial barometers will not be accepted for carriage as carry-on or checked baggage (see 2.3.3.1 of the IATA Dangerous Goods Regulations).</p> <p>US-04 Dangerous goods in salvage packagings will not be accepted for carriage. (See 5.0.1.6, 6.0.7, 6.7, 7.1.4, 7.2.3.10 of the IATA Dangerous Goods Regulations.)</p> <p>US-05 Division 2.2 — Non-flammable gases with a subsidiary risk of 5.1 will not be accepted for carriage. (Exception: COMAT parts and supplies only when offered in DOT31FP compliant containers.)</p> <p>US-06 Division 6.2 — Infectious substances. Category A infectious substance affecting animals (UN 2900) or humans (UN 2814) will not be accepted for carriage (see Packing Instruction 620).</p> <p>UU — AIR AUSTRAL</p> <p>UU-01 Dangerous goods as defined in the current edition of the IATA Dangerous Goods Regulations will not be accepted in airmail.</p>	<p>2;6 Table 3-1</p> <p>8;1</p> <p>4;1.4 5;1.5 5;2.4 6;1.2.6 6;2.3 6;4.8</p> <p>1;2.3</p>
≠	<p>UU-02 Dangerous goods as defined below will not be accepted for carriage on board Air Austral aircraft:</p> <p style="margin-left: 40px;">— Division 2.3 — Toxic gases; — Division 6.1 — Toxic substances in Packing Group I:</p> <p>UU-03 Radioactive material will not be accepted for carriage.</p> <p>UU-04 Dangerous goods departing from: Johannesburg (South Africa), Moroni (Republic of Comores), Maurice (Mauritius), Antananarivo, Nosy-Be, Toamasina, Majunga (Madagascar Island), Mahe (Seychelles) are subject to prior approval from Air Austral. Authorization must be requested ten days in advance and must be provided by the cargo manager, SITA telex: RUNDKUU, copy RUNFKUU.</p>	<p>Table 3-1</p> <p>2;7 Table 3-1</p>

UU-05	All blood products and biological samples, human or animal origin, must be carried as cargo. They are not permitted as baggage. They must be classified as UN 2814, Infectious substance, affecting humans (liquid or solid) or UN 2900, Infectious substance, affecting animals (liquid or solid) both in Division 6.2 and packed according to Packing Instruction 620. The only exception to this rule is human or animal blood and plasma free from any pathogen and destined for human or veterinary treatment. In these cases, the shipment must be classified as non-dangerous pharmaceuticals, life-saving drugs. The air waybill must bear a detailed commodity description to enable identification. Biological substance, Category B, UN 3373, may be accepted only as cargo and as long as a valid and free from any pathogen biological certification is duly given to the operator and is packed in accordance with Packing Instruction 620.	2;6 Table 3-1 4;8 5;4
UU-06	Not used.	
UU-07	Special cargo — advance arrangements must be made with the operator for all shipments of VAL, AVI, HUM, ICE, PER, DIP and LHO. Requests can be forwarded by telephone, fax, SITA (RUNDKUU, copy RUNFKUU) or the Internet.	
UU-08	Not used	
UX — AIR EUROPA		
UX-01	Dangerous goods in excepted quantities will not be accepted for carriage.	3;5
UX-02	Dangerous goods in limited quantities (“Y” packing instructions) will not be accepted for carriage (except for ID 8000 — Consumer commodity, COMAT, AOG, aircraft parts and supplies). (See 3;4 of these Instructions, 2.7 of the IATA Dangerous Goods Regulations and all “Y” packing instructions.)	3;4
UX-03	Dangerous goods in consolidations will not be accepted for carriage, except for: — consolidations containing UN 1845, Carbon dioxide, solid (dry ice) when used as a refrigerant for non-dangerous goods.	7;1
UX-04	Division 6.1 — Toxic substances — dangerous goods in which the primary or secondary hazard belongs to Division 6.1 (except for COMAT, AOG, aircraft parts and supplies) will not be accepted for carriage.	2;6 Table 3-1
UX-05	Dangerous goods of which the primary hazard is Class 4 (4.1, 4.2, 4.3) (except for COMAT, AOG, aircraft parts and supplies) will not be accepted for carriage.	2;4 Table 3-1
UX-06	Dangerous goods of which the primary hazard belongs to Division 5.2 will not be accepted for carriage.	2;5 Table 3-1
UX-07	The following dangerous goods will not be accepted for carriage (see packing instructions [–] listed after each substance): UN 1787 — Hydriodic acid [851, 855, Y840, 852, 856, Y841] UN 2803 — Gallium [867].	Table 3-1
UX-08	Hazardous waste in any form, as defined by any regulation of the IATA Dangerous Goods Regulations, will not be accepted for carriage.	
UX-09	Salvage packagings will not be accepted for carriage.	4;1
UX-10	Class 7 — Radioactive material will not be accepted for carriage.	2;7 Table 3-1
UX-11	Not used.	
UY — CAMEROON AIRLINES		
UY-01	Dangerous goods in excepted quantities as defined in 3;5 will not be accepted for carriage.	3;5

VA — VIRGIN AUSTRALIA

≠	VA-01	Petrol powered equipment such as chainsaws, brush cutters, generators or the like, either new or used, are forbidden in carry-on or checked baggage. Such items will only be accepted as cargo if they are packaged and shipped in accordance with the IATA Dangerous Goods Regulations. Where Special Provision A70 applies to internal combustion or fuel cell engines, these items may be accepted for transport as cargo provided operator approval has been granted.	Table 8-1
+	VA-02	Dangerous goods listed in the list of high consequence dangerous goods will not be accepted for carriage.	Table 1-7
+	VA-03	Not used.	

VN — VIETNAM AIRLINES

≠	VN-01	The shipper must make advance arrangements of procedures for all dangerous goods. Except for dangerous goods which do not require a DGD, all dangerous goods prior to being loaded in VN's aircraft must obtain acceptance messages from HDQUVDN for dangerous goods departing from overseas and from VNA's branches in the northern/southern/middle regions for dangerous goods departing from Vietnam.	
	VN-02	Dangerous goods in excepted quantities will not be accepted for carriage, except radioactive material in empty packages (UN 2908) and radioactive material, excepted package — instruments (UN 2911).	3;5
≠	VN-03	Dangerous goods in airmail will not be accepted for carriage, except for lithium batteries in accordance with 2.4.2 (d) and (e) of the IATA Dangerous Goods Regulations on the condition that the designated postal operators meet the requirements of the IATA Dangerous Goods Regulations.	1;2.3 d) and e)
	VN-04	All dangerous goods of Packing Group I will not be accepted for carriage.	2;0
	VN-05	Class 1 — All kinds of explosives will not be accepted for carriage, except the substances and articles of Division 1.4S.	2;1 Table 3-1
	VN-06	Division 2.1 — Flammable gases and Division 2.3 — Toxic gases will not be accepted for carriage (exception: COMAT parts and supplies.)	2;2 Table 3-1
	VN-07	Class 4 — All dangerous goods of Division 4.3 will not be accepted for carriage.	2;4 Table 3-1
	VN-08	Not used.	
	VN-09	Class 7 — Radioactive material packed in Type B(U), Type B(M) or Type C packages and SCO or LSA packed in industrial packages, and radioactive material with transport index exceeding 3.0 will not be accepted for carriage.	2;7 Table 3-1 5;1
	VN-10	Not used.	
≠	VN-11	Class 9 — Yeast active; polymeric beads or granules; and magnetized material exceeding 2 000 kg (4 400 lb) will not be accepted for carriage. The maximum limits for dry ice per aircraft hold (FWD/AFT hold) is as follows:	2;0 Table 3-1

Type of aircraft	Maximum quantity (with live animals)	Maximum quantity (without live animals)
A321	100 kg	180 kg
B777/A330	150 kg	250 kg

VN-12	Dangerous goods in consolidations will not be accepted for carriage, except for:	7;1
	— consolidations having one master air waybill with one house air waybill;	
	— consolidations having multi house air waybill containing ID 8000 (consumer commodity); or;	
	— consolidations having multi house air waybill containing UN 1845 (Carbon dioxide, solid/dry ice) when used as a refrigerant for non-dangerous goods.	

VO — TYROLEAN AIRWAYS

VO-01	UN 3481 — Lithium ion batteries contained in equipment, Packing Instruction 967, Section I (battery/pack more than 100 Wh) will not be accepted for carriage as cargo.	4;11
-------	--	------

≠	VO-02	Not used.	
	VO-03	Dangerous goods in limited quantities (“Y” packing instructions) will not be accepted for carriage. (Exception: ID 8000 — Consumer commodity will be accepted.) (See 3;4 of these Instructions, 2.7 of the IATA Dangerous Goods Regulations and all “Y” packing instructions.)	3;4
	VO-04	UN 3373 — Biological substance, Category B, will not be accepted in airmail.	1;2,3 Table 3-1
VS — VIRGIN ATLANTIC			
	VS-01	Radioactive material will not be accepted for carriage, apart from excepted packages: UN 2908, UN 2909, UN 2910, UN 2911.	2;7 Table 3-1
VT — AIR TAHITI			
	VT-01	Dangerous goods in limited quantities (“Y” packing instructions) will not be accepted for carriage. (see 3;4 of these Instructions, 2.7 of the IATA Dangerous Goods Regulations and all “Y” packing instructions.)	3;4
≠	VT-02	Specific limitations apply to the following items carried as cargo (ask the carrier by email at resp-md@airtahiti.pf): <ul style="list-style-type: none"> — Gases of Division 2.3; — Solids of Division 4.2 and Division 4.3; — Radioactive materials of Category II-Yellow and III-Yellow (“RRY” code); — UN 2211 — Polymeric beads, expandable; and — UN 3314 — Plastics moulding compound. 	Part 5 7;2
≠	VT-03	From any station other than the main base (Tahiti-Faa’a, “PPT” code), a limited list of approved dangerous goods is published (ask the carrier).	
≠	VT-04	For carriage of dangerous goods of Packing Group I, and for carriage of dangerous goods in excepted quantities or de minimis quantities, prior approval from the Air Tahiti dangerous goods manager is required via email at resp-md@airtahiti.pf .	Table 3-1 3;4
	VT-05	Not used.	
≠	VT-06	Not used.	
≠	VT-07	All dangerous goods packages must show the package orientation label (“THIS WAY UP”) and two hazard labels on two opposite sides (see 7.2.4.4 of the IATA Dangerous Goods Regulations).	5;3,2,12 b) 7;2
≠	VT-08	Medical and clinical wastes, infected animals and venomous animals are not accepted for carriage.	2;6
≠	VT-09	The carriage of Carbon dioxide (dry ice), UN 1845 on its own is forbidden.	4;11 7;2
+	VT-10	The carriage of dangerous goods to or from the Cook Islands is forbidden.	
WN — SOUTHWEST AIRLINES			
	WN-01	Southwest Airlines will not accept commercial shipments of dangerous goods as defined by these Instructions including dangerous goods shipped in limited or excepted quantities except for the following: <ul style="list-style-type: none"> — dangerous goods in de minimis quantities; — UN 3480 — Lithium ion batteries, UN 3481 — Lithium ion batteries contained in or packed with equipment and UN 3091 — Lithium metal batteries contained in or packed with equipment will only be accepted when packed in accordance with Section II of the applicable packing instruction; — UN 3373 — Biological substance, Category B (if package is being cooled by dry ice, the quantity of dry ice cannot exceed 2.5 kg). 	3;5 4;11
	WN-02	Any item that utilizes an internal combustion engine (new or used) will not be accepted as cargo unless prior approval is obtained from carrier.	

WN-03	Dangerous goods permitted for passengers and crew (see 2.3 of the IATA Dangerous Goods Regulations) are allowed except for the following restrictions: <ul style="list-style-type: none"> — camping stoves and fuel containers that have contained flammable liquid fuel; — avalanche rescue backpacks; — oxygen or air, gaseous, cylinders for medical use; — internal combustion engines (new or used); and — chemical agent monitoring equipment. 	8 ;1
WN-04	Class 7 — Radioactive material, with the exception of UN 2911 — Radioactive material, excepted package — instruments will not be accepted for transport.	
WN-05	Hazardous waste in any form, as defined by any regulation, will not be accepted for carriage.	
+ WY — OMAN AIR		
WY-01	All classes of dangerous goods as defined in the IATA Dangerous Goods Regulations will not be accepted for carriage unless prior approval and booking arrangements are obtained 72 hours prior to departure from Oman Air Cargo Reservations via email at cargo.cs@omanair.com or telephone at +968-24510639.	
WY-02	Explosives will not be accepted for carriage, with the exception of explosives in Division 1.4S, UN 0012, UN 0014 and UN 0323. Fireworks will not be accepted for carriage.	2;1
WY-03	Class 7 — Radioactive material will not be accepted for carriage.	
WY-04	Except for ID 8000 — Consumer commodity, the carriage of limited quantities of dangerous goods is not permitted (see 3;4 of these Instructions, 2.7 of the IATA Dangerous Goods Regulations and all “Y” packing instructions).	2;7 3;4
WY-05	Dangerous goods in excepted quantities (EQ) will be accepted for carriage only with prior approval from Oman Air Cargo when obtained 48 hours prior to carriage.	3;5
WY-06	Dangerous goods in airmail will not be accepted for carriage.	1;2,3
WY-07	The following will not be accepted for carriage as cargo on Oman Air flights: <ul style="list-style-type: none"> — UN 3090 — Lithium metal batteries; — UN 3091 — Lithium metal batteries contained in equipment; — UN 3091 — Lithium metal batteries packed with equipment; <p>The above includes both Section I (fully regulated) and Section II (excepted) lithium batteries (see Packing Instructions 968 to 970).</p> <ul style="list-style-type: none"> — UN 3356 — Oxygen generator, chemical; and — UN 2803 — Gallium. 	
WY-08	The shipper must provide a 24-hour emergency telephone number of a person/agency who is knowledgeable of the hazards, characteristics and actions to be taken in the case of an accident or incident concerning each of the dangerous goods being transported. This telephone number, including the country and area code, preceded by the words “Emergency contact” or “24-hour number”, must be inserted on the shipper’s declaration for dangerous goods in the “Handling information” box (see 8.1.6.1 of the IATA Dangerous Goods Regulations). The telephone number of the consignee must be shown on the air waybill.	5;4
WY-09	Prior approval is required for the carriage of sporting weapons and ammunition (see Packing Instructions 101 to 143).	
WY-10	Carriage of weapons of war and munitions of war are highly restricted and may be allowed subject to prior approval.	
V3 — CARPATAIR SA		
V3-01	Dangerous goods of Class 1 — Explosives and Class 7 — Radioactive material will not be accepted for carriage.	2;1, 2;7 Table 3-1

	V3-02	The shipper must provide a 24-hour emergency telephone number of a person/agency who is knowledgeable of the hazards, characteristics and actions to be taken in case of an accident or incident concerning (each of) the dangerous goods being transported. This telephone number, including country and area code, preceded by the words "Emergency contact" or "24-hour number" must be inserted on the shipper's declaration for dangerous goods (DGD) preferably in the "Handling information" box, e.g. "Emergency contact +47 67 50 00 00". A 24-hour emergency telephone number is not required for shipments that do not require a DGD.	5;4
	+	XG — SUNEXPRESS DEUTSCHLAND GMBH	
	XG-01	Dangerous goods in limited quantities ("Y" packing instructions) will not be accepted for carriage. (Exception: ID 8000 — Consumer commodity will be accepted.) (See 3;4 of these Instructions, 2.7 of the IATA Dangerous Goods Regulations and all "Y" packing instructions.)	3;4
	XG-02	Dangerous goods in consolidations will not be accepted for carriage, except for the following shipments: — consolidations containing UN 1845, Carbon dioxide, solid (dry ice) when used as a refrigerant; — consolidations with only one house air waybill; — consolidations with more than one house air waybill, which have the same shipper and different consignees. (See 1.3.3, 8.1.2.4, 9.1.8 and 10.8.1.5 of the IATA Dangerous Goods Regulations.)	7;1
	XG-03	Dangerous goods in airmail will not be accepted for carriage. This includes items permitted under 2.4.2 of the IATA Dangerous Goods Regulations (see 2.4 and 10.2.2 of the IATA Dangerous Goods Regulations).	1;2,3
	XG-04	UN 1845 — Carbon dioxide, solid (dry ice) is restricted to 200 kg per aircraft on all SunExpress aircraft types.	Table 3-1 7;2
	XG-05	Biological substance, Category B (UN 3373), will not be accepted (see Packing Instruction 650).	Table 3-1
	XG-06	Fissile material will not be accepted for carriage.	Table 3-1
	XG-07	The shipper must provide a 24-hour emergency telephone number of a person/agency who is knowledgeable of the hazards, characteristics and actions to be taken in the case of an accident or incident concerning each of the dangerous goods being transported. This telephone number, including the country and area code, preceded by the words "Emergency Contact" or "24-hour number" must be inserted on the shipper's declaration for dangerous goods, preferably in the "Handling Information" box, e.g. "Emergency Contact +90 242-123-4567" and must also be visible on the outside of the package(s) (see 8.1.6.11 and 10.8.3.11 of the IATA Dangerous Goods Regulations). A 24-hour emergency telephone number is not required for shipments that do not require a shipper's declaration for dangerous goods.	5;4
	≠	XK — AIR CORSICA	
	XK-01	Explosives will not be accepted for carriage, except substances and articles of Division 1.4S. (See Packing Instructions 101–143.)	2;1 Table 3-1
	XK 02	Not used.	
	≠ XK 03	Except for ID 8000 — Consumer commodity, dangerous goods in limited quantities ("Y" packing instructions) will not be accepted for carriage. (See 2.7 of the IATA Dangerous Goods Regulations and all "Y" packing instructions.)	3;4

XL — LAN ECUADOR

#	XL-01	<p>Dangerous goods offered for transport under an approval or an exemption as provided by 1.2.5 and 1.2.6 of the IATA Dangerous Goods Regulations and any other LAN Ecuador conditions by pre-approval will be accepted only after prior review and approval of the LATAM Dangerous Goods Technical Committee.</p> <p>In addition, UN 1040 and UN 2014, when shipped as excepted quantities in accordance with Special Provisions A131 and A75 respectively, also require prior review and approval of the LATAM Dangerous Goods Technical Committee.</p> <p>An application for approval must be undertaken at least fifteen working days in advance of the scheduled date for the flight. The material safety data sheet (MSDS) or other documentation that covers the shipment must be attached. Applications should be addressed to:</p> <p style="margin-left: 40px;">LAN Ecuador Dangerous Goods Department Telephone: +593-87614154 +56-2-677-4571 +1-305-772-2894 Email: DangerousGoodsBoard@lan.com</p>	1;1.1
	XL-02	<p>The shipper must provide a 24-hour emergency telephone number of a person/agency who is knowledgeable of the hazards, characteristics and actions to be taken in case of an accident or incident concerning each of the dangerous goods being transported. This telephone number, including the country and area code, preceded by the words "Emergency contact" or "24-hour number" must be inserted on the declaration for dangerous goods in the "Handling Information" box. (See 8.1.6.11 and 10.8.3.11 of the IATA Dangerous Goods Regulations.)</p> <p>An emergency response telephone number is not required for:</p> <ul style="list-style-type: none"> — battery-powered equipment; — battery-powered vehicle; — flammable gas-powered vehicle; — flammable liquid-powered vehicle; — engine, internal combustion; — dangerous goods in limited quantities as described in 3;4 of these Instructions (2.7 of the IATA Dangerous Goods Regulations); — carbon dioxide, solid (dry ice); — consumer commodity; and — refrigerating machines. 	Table 3-1 5;4
	XL-03	<p>For toxic substances of Division 6.1 or Division 2.3, the following requirements must be complied with:</p> <ol style="list-style-type: none"> a) Toxic substances of Division 6.1, Packing Group I, that are toxic by inhalation, will not be accepted for carriage unless a prior approval has been obtained (see LA-01). b) Toxic gases of Division 2.3 will not be accepted for carriage unless a prior approval has been obtained (see LA-01). 	2;3 2;6 5;4 6;1

	<p>c) When the substance to be carried has an inhalation, mist, powder or vapour hazard, the shipper's declaration must have the following endorsement in the "Additional handling information box": "Mist, powder or vapour inhalation hazard", as appropriate.</p> <p><i>Note 1.— This requirement only applies to the primary risk.</i></p> <p><i>Note 2.— Where the substance has more than one route of toxicity, the risk that determined the packing group must be used.</i></p> <p>d) Solid toxic substances of any kind will not be accepted for carriage in bags 5H1, 5H2, 5H3, 5H4, 5L2, 5L3, 5M1 or 5M2 as single packagings unless contained in a strong hot sealed polyethylene bag at least 200 microns thick. If these types of packages are offered overpacked in a warehouse pallet, they will be accepted for carriage provided:</p> <ol style="list-style-type: none"> 1) the warehouse pallet is rigid and strong enough to support the weight assembled on it, without bending when picked up and transported by a forklift; 2) the surface of the warehouse pallet is continuous, soft and free of sharp protruding points which could pierce the bags; and 3) the warehouse pallet is provided with separation bars from the floor for the use of a forklift. 	
XL-04	<p>Infectious substances will be accepted under specific advance arrangements and the following requirements must be met:</p> <ol style="list-style-type: none"> a) The shipper must prove by a document such as a fax, telex, letter, etc., that the infectious substance can legally enter the State of Destination and that all the requirements of the States of Origin and Destination of the shipment have been complied with. b) The shipper must attach a certificate duly signed and issued by a medical, scientific or other similar professional which confirms the classification of these specimens in the following cases: <ul style="list-style-type: none"> — shipment of Biological substance, Category B; — shipment of any patient specimens prepared according to 3.6.2.2.3.6 of the IATA Dangerous Goods Regulations. c) Infected animals, dead (whole bodies) or alive will not be accepted for carriage. 	2;6.3.2.3.6 5;4
XL-05	Formaldehyde solutions containing less than 25% of formaldehyde must be shipped under UN 3334 — Aviation regulated liquid, n.o.s.*, Class 9, Packing Group III.	Table 3-1
XL-06	The marking required by 7.1.5 of the IATA Dangerous Goods Regulations and application of hazard and handling labels on packages containing dangerous goods must not be applied to the top or bottom of packages. These markings and labels must be applied to the sides of packages. This requirement does not apply to marking of the full name and address of the shipper and consignee.	5;2 5;3
XL-07	Fissile material as defined in 10.3.7 of the IATA Dangerous Goods Regulations will be accepted only with prior review and approval by the LAN Dangerous Goods Technical Committee (see LA-01).	1;6.1.5 2;7
+	<p>XL-08 UN 3090 — Lithium metal batteries and UN 3091 — Lithium metal batteries contained in or packed with equipment. Primary (non-rechargeable) lithium (metal) batteries and cells must be transported on cargo aircraft only (CAO).</p> <p>This prohibition does not apply to:</p> <ul style="list-style-type: none"> — lithium batteries (rechargeable and non-rechargeable) covered by the provisions for dangerous goods carried by passengers or crew. (See Table 2.3.A of the IATA Dangerous Goods Regulations.); — lithium metal batteries and cells contained in medical equipment being transported for humanitarian reasons; — lithium metal batteries and cells that are presented as COMAT of any air company of LATAM Airlines Group. 	Table 3-1 4;11 8;1

+	XL-09	<p>Unit load devices or freight containers containing dangerous goods described in 9.1.4, sub-paragraphs (a) to (d) of the IATA Dangerous Goods Regulations or lithium batteries prepared under Section II of Packing Instructions 965 to 970 will be accepted by advance arrangements and contract only in accordance with the current "Accreditation Freight Forwarder Programme" implemented by the LAN Ecuador Dangerous Goods Department (see XL-01).</p> <p>The shipper/freight forwarder must deliver a document certifying that:</p> <ul style="list-style-type: none"> — the shipment was prepared on secure premises and protected against unlawful interference during preparation, storage and transport; and — packages comply with all requirements of the IATA Dangerous Goods Regulations. 	7;1.4
+	XL-10	<p>UN 3356 — Chemical oxygen generators transported to, from, through or within the United States must be placed in outer packaging that bears the additional tested specification mark of DOT 31FP indicating compliance with 49 CFR 173.168.</p>	4;7
+	XQ — SUNEXPRESS		
	XQ-01	<p>Dangerous goods in limited quantities ("Y" packing instructions) will not be accepted for carriage. (Exception: ID 8000 — Consumer commodity will be accepted.) (See 3;4 of these Instructions, 2.7 of the IATA Dangerous Goods Regulations and all "Y" packing instructions.)</p>	3;4
	XQ-02	<p>Dangerous goods in consolidations will not be accepted for carriage, except for the following shipments:</p> <ul style="list-style-type: none"> — consolidations containing UN 1845, Carbon dioxide, solid (dry ice) when used as a refrigerant; — consolidations with only one house air waybill; — consolidations with more than one house air waybill, which have the same shipper and different consignees. <p>(See 1.3.3, 8.1.2.4, 9.1.8 and 10.8.1.5 of the IATA Dangerous Goods Regulations.)</p>	7;1
	XQ-03	<p>Dangerous goods in airmail will not be accepted for carriage. This includes items permitted under 2.4.2 of the IATA Dangerous Goods Regulations (see 2.4 and 10.2.2 of the IATA Dangerous Goods Regulations).</p>	1;2.3
	XQ-04	<p>UN 1845 — Carbon dioxide, solid (dry ice) is restricted to 200 kg per aircraft on all SunExpress aircraft types.</p>	Table 3-1 7;2
	XQ-05	<p>Biological substance, Category B (UN 3373), will not be accepted (see Packing Instruction 650).</p>	Table 3-1
	XQ-06	<p>Fissile material will not be accepted for carriage.</p>	Table 3-1
	XQ-07	<p>The shipper must provide a 24-hour emergency telephone number of a person/agency who is knowledgeable of the hazards, characteristics and actions to be taken in the case of an accident or incident concerning each of the dangerous goods being transported. This telephone number, including the country and area code, preceded by the words "Emergency Contact" or "24-hour number" must be inserted on the shipper's declaration for dangerous goods, preferably in the "Handling Information" box, e.g. "Emergency Contact +90 242-123-4567" and must also be visible on the outside of the package(s) (see 8.1.6.11 and 10.8.3.11 of the IATA Dangerous Goods Regulations).</p> <p>A 24-hour emergency telephone number is not required for shipments that do not require a shipper's declaration for dangerous goods.</p>	5;4
	ZW — AIR WISCONSIN		
	ZW-01	<p>Commercial shipments of dangerous goods will not be accepted. Properly prepared company material (COMAT) shipments will be accepted.</p>	
	ZX — AIR GEORGIAN LIMITED		
	ZX-01	<p>The carriage of UN 1845 — Carbon dioxide, solid (dry ice) will be limited to a maximum of 25 kg per flight.</p>	Table 3-1 4;11

+	2K — AEROGAL		
	2K-01	Wheelchairs with spillable or wet batteries will be accepted only when the battery has been removed from the wheelchair and packaged according to paragraphs 2.3.2.3 and 9.3.14 of the IATA Dangerous Goods Regulations.	8;1
	2K-02	Oxygen, compressed, UN 1072 for medical use during flight, will not be accepted for carriage.	8;1
	2K-03	Dangerous goods in airmail will not be accepted for carriage.	1;2,3
	2K-04	Fissile radioactive material will not be accepted for carriage. (See 10.5.13 of the IATA Dangerous Goods Regulations.)	2;7
	2K-05	Radioactive material will only be accepted for transport when the radioactive material is intended for medical diagnosis or treatment or medical and/or industrial research.	2;7 5;1
	2K-06	Mercury — UN 2809 will be accepted for carriage provided the following conditions are complied with: <ul style="list-style-type: none"> — only combination packagings will be accepted; — outer packagings must have a strong inner lining or leak-proof bags, puncture-resistant material, impervious to mercury; and — must be overpacked with a plastic box. 	Table 3-1 4;1
	2K-07	Arrangement with the airline is necessary for packages that contain dry ice.	Table 3-1 4;11 5;1 7;2
	2K-08	Spanish must be used in addition to English for all markings and dangerous goods documentation for domestic and international transport from Ecuador.	5;2 5;3 5;4
	4C — LAN COLOMBIA		
≠	4C-01	Dangerous goods offered for transport under an approval or an exemption as provided by 1.2.5 and 1.2.6 of the IATA Dangerous Goods Regulations and any other LAN Colombia conditions by pre-approval will be accepted only after prior review and approval of the LATAM Dangerous Goods Technical Committee. <p>In addition, UN 1040 and UN 2014, when shipped as excepted quantities in accordance with Special Provisions A131 and A75 respectively, also require prior review and approval of the LATAM Dangerous Goods Technical Committee.</p> <p>An application for approval must be undertaken at least fifteen working days in advance of the scheduled date for the flight. The material safety data sheet (MSDS) or other documentation that covers the shipment must be attached. Applications should be addressed to:</p> <p style="margin-left: 40px;">LAN Colombia Dangerous Goods Department Telephone: +57-1-4259600, Ext. 71312 +56-2-2677-4571/ +56-2-25669366 +1-305-772-2894 Email: DangerousGoodsBoard@lan.com</p>	1;1,1

4C-02	<p>The shipper must provide a 24-hour emergency telephone number of a person/agency who is knowledgeable of the hazards, characteristics and actions to be taken in case of an accident or incident concerning each of the dangerous goods being transported. This telephone number, including the country and area code, preceded by the words "Emergency contact" or "24-hour number" must be inserted on the declaration for dangerous goods in the "Handling Information" box. (See 8.1.6.11 and 10.8.3.11 of the IATA Dangerous Goods Regulations.)</p> <p>An emergency response telephone number is not required for:</p> <ul style="list-style-type: none"> — battery-powered equipment; — battery-powered vehicle; — flammable gas-powered vehicle; — flammable liquid-powered vehicle; — engine, internal combustion; — dangerous goods in limited quantities as described in 3;4 of these Instructions (2.7 of the IATA Dangerous Goods Regulations); — carbon dioxide, solid (dry ice); — consumer commodity; and — refrigerating machines. 	Table 3-1 5;4
4C-03	<p>For toxic substances of Division 6.1 or Division 2.3, the following requirements must be complied with:</p> <ol style="list-style-type: none"> a) Toxic substances of Division 6.1, Packing Group I, that are toxic by inhalation, will not be accepted for carriage unless a prior approval has been obtained (see LA-01). b) Toxic gases of Division 2.3 will not be accepted for carriage unless a prior approval has been obtained (see LA-01). c) When the substance to be carried has an inhalation, mist, powder or vapour hazard, the shipper's declaration must have the following endorsement in the "Additional handling information box": "Mist, powder or vapour inhalation hazard", as appropriate. <ul style="list-style-type: none"> <i>Note 1.— This requirement only applies to the primary risk.</i> <i>Note 2.— Where the substance has more than one route of toxicity, the risk that determined the packing group must be used.</i> d) Solid toxic substances of any kind will not be accepted for carriage in bags 5H1, 5H2, 5H3, 5H4, 5L2, 5L3, 5M1 or 5M2 as single packagings unless contained in a strong hot sealed polyethylene bag at least 200 microns thick. If these types of packages are offered overpacked in a warehouse pallet, they will be accepted for carriage provided: <ol style="list-style-type: none"> 1) the warehouse pallet is rigid and strong enough to support the weight assembled on it, without bending when picked up and transported by a forklift; 2) the surface of the warehouse pallet is continuous, soft and free of sharp protruding points which could pierce the bags; and 3) the warehouse pallet is provided with separation bars from the floor for the use of a forklift. 	2;3 2;6 5;4 6;1

4C-04	<p>Infectious substances will be accepted under specific advance arrangements and the following requirements must be met:</p> <p>a) The shipper must prove by a document such as a fax, telex, letter, etc., that the infectious substance can legally enter the State of Destination and that all the requirements of the States of Origin and Destination of the shipment have been complied with.</p> <p>b) The shipper must attach a certificate duly signed and issued by a medical, scientific or other similar professional which confirms the classification of these specimens in the following cases:</p> <ul style="list-style-type: none"> — shipment of Biological substance, Category B; — shipment of any patient specimens prepared according to 3.6.2.2.3.6 of the IATA Dangerous Goods Regulations. <p>c) Infected animals, dead (whole bodies) or alive will not be accepted for carriage.</p>	2;6.3.2.3.6 5;4
4C-05	<p>Formaldehyde solutions containing less than 25% of formaldehyde must be shipped under UN 3334 — Aviation regulated liquid, n.o.s.*, Class 9, Packing Group III.</p>	Table 3-1
4C-06	<p>The marking required by 7.1.5 of the IATA Dangerous Goods Regulations and application of hazard and handling labels on packages containing dangerous goods must not be applied to the top or bottom of packages. These markings and labels must be applied to the sides of packages. This requirement does not apply to marking of the full name and address of the shipper and consignee.</p>	5;2 5;3
4C-07	<p>Fissile material as defined in 10.3.7 of the IATA Dangerous Goods Regulations will be accepted only with prior review and approval by the LAN Dangerous Goods Technical Committee (see LA-01).</p>	1;6.1.5 2;7
+ 4C-08	<p>UN 3090 — Lithium metal batteries and UN 3091 — Lithium metal batteries contained in or packed with equipment. Primary (non-rechargeable) lithium (metal) batteries and cells must be transported on cargo aircraft only (CAO).</p> <p>This prohibition does not apply to:</p> <ul style="list-style-type: none"> — lithium batteries (rechargeable and non-rechargeable) covered by the provisions for dangerous goods carried by passengers or crew. (See Table 2.3.A of the IATA Dangerous Goods Regulations.); — lithium metal batteries and cells contained in medical equipment being transported for humanitarian reasons; — lithium metal batteries and cells that are presented as COMAT of any air company of LATAM Airlines Group. 	Table 3-1 4;11 8;1
+ 4C-09	<p>Unit load devices or freight containers containing dangerous goods described in 9.1.4, sub-paragraphs (a) to (d) of the IATA Dangerous Goods Regulations or lithium batteries prepared under Section II of Packing Instructions 965 to 970 will be accepted by advance arrangements and contract only in accordance with the current "Accreditation Freight Forwarder Programme" implemented by the LAN Colombia Dangerous Goods Department (see 4C-01).</p> <p>The shipper/freight forwarder must deliver a document certifying that:</p> <ul style="list-style-type: none"> — the shipment was prepared on secure premises and protected against unlawful interference during preparation, storage and transport; and — packages comply with all requirements of the IATA Dangerous Goods Regulations. 	7;1.4
+ 4C-10	<p>UN 3356 — Chemical oxygen generators transported to, from, through or within the United States must be placed in outer packaging that bears the additional tested specification mark of DOT 31FP indicating compliance with 49 CFR 173.168.</p>	4;7

4M — LAN ARGENTINA

≠ 4M-01 Dangerous goods offered for transport under an approval or an exemption as provided by 1.2.5 and 1.2.6 of the IATA Dangerous Goods Regulations and any other LAN Argentina conditions by pre-approval will be accepted only after prior review and approval of the LATAM Dangerous Goods Technical Committee. 1;1.1

In addition, UN 1040 and UN 2014, when shipped as excepted quantities in accordance with Special Provisions A131 and A75 respectively, also require prior review and approval of the LATAM Dangerous Goods Technical Committee.

An application for approval must be undertaken at least fifteen working days in advance of the scheduled date for the flight. The material safety data sheet (MSDS) or other documentation that covers the shipment must be attached. Applications should be addressed to:

LAN Argentina Dangerous Goods Department
 Telephone: +54-11-44807777, Ext. 7806
 +56-2-2677-4571/+56-2-25669366
 +1-305-772-2894
 Email: DangerousGoodsBoard@lan.com

4M-02 The shipper must provide a 24-hour emergency telephone number of a person/agency who is knowledgeable of the hazards, characteristics and actions to be taken in case of an accident or incident concerning each of the dangerous goods being transported. This telephone number, including the country and area code, preceded by the words "Emergency contact" or "24-hour number" must be inserted on the declaration for dangerous goods in the "Handling Information" box. (See 8.1.6.11 and 10.8.3.11 of the IATA Dangerous Goods Regulations.) Table 3-1
5;4

An emergency response telephone number is not required for:

- battery-powered equipment;
- battery-powered vehicle;
- flammable gas-powered vehicle;
- flammable liquid-powered vehicle;
- engine, internal combustion;
- dangerous goods in limited quantities as described in 3;4 of these Instructions (2.7 of the IATA Dangerous Goods Regulations);
- carbon dioxide, solid (dry ice);
- consumer commodity; and
- refrigerating machines.

4M-03 For toxic substances of Division 6.1 or Division 2.3, the following requirements must be complied with: 2;3
2;6
5;4
6;1

- a) Toxic substances of Division 6.1, Packing Group I, that are toxic by inhalation, will not be accepted for carriage unless a prior approval has been obtained (see LA-01).
- b) Toxic gases of Division 2.3 will not be accepted for carriage unless a prior approval has been obtained (see LA-01).
- c) When the substance to be carried has an inhalation, mist, powder or vapour hazard, the shipper's declaration must have the following endorsement in the "Additional handling information box": "Mist, powder or vapour inhalation hazard", as appropriate.

Note 1.— This requirement only applies to the primary risk.

Note 2.— Where the substance has more than one route of toxicity, the risk that determined the packing group must be used.

	<p>d) Solid toxic substances of any kind will not be accepted for carriage in bags 5H1, 5H2, 5H3, 5H4, 5L2, 5L3, 5M1 or 5M2 as single packagings unless contained in a strong hot sealed polyethylene bag at least 200 microns thick. If these types of packages are offered overpacked in a warehouse pallet, they will be accepted for carriage provided:</p> <ol style="list-style-type: none"> 1) the warehouse pallet is rigid and strong enough to support the weight assembled on it, without bending when picked up and transported by a forklift; 2) the surface of the warehouse pallet is continuous, soft and free of sharp protruding points which could pierce the bags; and 3) the warehouse pallet is provided with separation bars from the floor for the use of a forklift. 	
4M-04	<p>Infectious substances will be accepted under specific advance arrangements and the following requirements must be met:</p> <ol style="list-style-type: none"> a) The shipper must prove by a document such as a fax, telex, letter, etc., that the infectious substance can legally enter the State of Destination and that all the requirements of the States of Origin and Destination of the shipment have been complied with. b) The shipper must attach a certificate duly signed and issued by a medical, scientific or other similar professional which confirms the classification of these specimens in the following cases: <ul style="list-style-type: none"> — shipment of Biological substance, Category B; — shipment of any patient specimens prepared according to 3.6.2.2.3.6 of the IATA Dangerous Goods Regulations. c) Infected animals, dead (whole bodies) or alive will not be accepted for carriage. 	2;6.3.2.3.6 5;4
4M-05	Formaldehyde solutions containing less than 25% of formaldehyde must be shipped under UN 3334 — Aviation regulated liquid, n.o.s.*, Class 9, Packing Group III.	Table 3-1
4M-06	The marking required by 7.1.5 of the IATA Dangerous Goods Regulations and application of hazard and handling labels on packages containing dangerous goods must not be applied to the top or bottom of packages. These markings and labels must be applied to the sides of packages. This requirement does not apply to marking of the full name and address of the shipper and consignee.	5;2 5;3
4M-07	Fissile material as defined in 10.3.7 of the IATA Dangerous Goods Regulations will be accepted only with prior review and approval by the LAN Dangerous Goods Technical Committee (see LA-01).	1;6.1.5 2;7
+ 4M-08	<p>UN 3090 — Lithium metal batteries and UN 3091 — Lithium metal batteries contained in or packed with equipment. Primary (non-rechargeable) lithium (metal) batteries and cells must be transported on cargo aircraft only (CAO).</p> <p>This prohibition does not apply to:</p> <ul style="list-style-type: none"> — lithium batteries (rechargeable and non-rechargeable) covered by the provisions for dangerous goods carried by passengers or crew. (See Table 2.3.A of the IATA Dangerous Goods Regulations.); — lithium metal batteries and cells contained in medical equipment being transported for humanitarian reasons; — lithium metal batteries and cells that are presented as COMAT of any air company of LATAM Airlines Group. 	Table 3-1 4;11 8;1

- + 4M-09 Unit load devices or freight containers containing dangerous goods described in 9.1.4, sub-paragraphs (a) to (d) of the IATA Dangerous Goods Regulations or lithium batteries prepared under Section II of Packing Instructions 965 to 970 will be accepted by advance arrangements and contract only in accordance with the current "Accreditation Freight Forwarder Programme" implemented by the LAN Argentina Dangerous Goods Department (see 4M-01). 7;1.4
- The shipper/freight forwarder must deliver a document certifying that:
- the shipment was prepared on secure premises and protected against unlawful interference during preparation, storage and transport; and
 - packages comply with all requirements of the IATA Dangerous Goods Regulations.
- + 4M-10 UN 3356 — Chemical oxygen generators transported to, from, through or within the United States must be placed in outer packaging that bears the additional tested specification mark of DOT 31FP indicating compliance with 49 CFR 173.168. 4;7

5X — UNITED PARCEL SERVICE

Note.— The most current information about UPS services and restrictions may be found at the following website: <http://ups.com/hazmat>.

- 5X-01 UPS small package service shipments of dangerous goods having an origin and destination within the United States will be accepted by contract only, in accordance with the current UPS "Hazardous Materials Guide". This information is posted under the SUPPORT topic on the UPS home page (www.ups.com). See also the SITE GUIDE on the UPS home page (www.ups.com), at the link for "Hazardous Materials". Users may also locate the UPS Guide for Shipping Hazardous Materials by using the SEARCH function on the website.
- ≠ 5X-02 UPS international small package service rules and restrictions apply to all dangerous goods shipments with an origin and/or destination outside of the United States. Such shipments, including Biological substances, Category B, will be accepted by contract only (see 5X-01 above for United States domestic shipments). Countries available for service are shown at the following web site:

www.ups.com/content/us/en/resources/ship/idg/information/acl.html.

When shipping packages requiring an IATA shipper's declaration for dangerous goods, combination packagings must be used and packages must not exceed 30 kg gross weight. When applicable, not more than three compatible different dangerous goods may be contained in one outer packaging (see 5.0.2.11 of the IATA Dangerous Goods Regulations).

The following classes/divisions of dangerous goods are prohibited from UPS international small package services:

- Class 1 (Explosives);
- Division 2.3 (Toxic gas);
- Division 4.2 (Spontaneously combustible);
- Division 4.3 (Dangerous when wet);
- Division 5.1 (Oxidizing substances);
- Division 5.2 (Organic peroxide);
- Division 6.1 (Substances requiring a "Toxic" label);

Shipments of UN 1230, Methanol and UN 3506, Mercury contained in manufactured articles, will be accepted only when the packages do not require a "Toxic" sub-risk label.

- Division 6.2 (Infectious substances, Category A);
- Class 7 (Substances requiring a “Radioactive” White-I, Yellow-II, Yellow-III or Fissile label);
 - Radioactive material, excepted package shipments are also prohibited;
- Class 9:
 - Shipments of UN 2807, Magnetized material, which conform to Packing Instruction 953 can be shipped only to, from, and within the countries identified on the following link:

<http://www.ups.com/content/us/en/resources/ship/idg/information/acl.html>

Additionally, such shipments must be labelled in accordance with Packing Instruction 953 and documented in one of the following ways:

- 1) identified as “Magnetized material” in a package reference field on the UPS shipping label; or
 - 2) accompanied by a written document, affixed directly to the outside of the package or contained in a resealable envelope on the package, identifying the contents as “Magnetized material”.
- Complete information about UPS Small Package International Dangerous Goods Service, including specific limitations per package, may be found at the link for UPS GUIDE FOR SHIPPING INTERNATIONAL DANGEROUS GOODS at the website identified in 5X-01.
 - All permitted dangerous goods in excepted quantities are accepted. UPS class/division restrictions do not apply to dangerous goods in excepted quantities

(see 1.3.2, 8.1.6.9.1 and 10.8.3.9.1 of the IATA Dangerous Goods Regulations).

5X-03 Dangerous goods shipments will be accepted by UPS Air Cargo Service by contract only. All contract applications must be reviewed and approved by the UPS Air Dangerous Goods Department (SDF) and Air Cargo Service (UPS Air Group-SDF). Hazardous classes accepted in UPS Air Cargo Service are subject to approval, and shipments are subject to advance arrangement.

- a contract is required for shipments of UN 3480, Lithium ion batteries, prepared in accordance with Section IB of Packing Instruction 965. Such shipments must be tendered with either:
 - a completed shipper’s declaration for dangerous goods; or
 - an air waybill presenting the information required by Section IB (paragraph (b) 1 through (b) 4 of Packing Instructions 965 in the IATA Dangerous Goods Regulations).
- UPS Air Cargo Service does not accept shipments of UN 3090, Section IA or IB lithium metal batteries.

≠	5X-04	Dangerous goods shipments in UPS freight air services are accepted by arrangements between UPS Airlines and UPS Supply Chain Solutions. Prohibited hazard classes include: <ul style="list-style-type: none"> — Divisions 1.1, 1.2, 1.3, 1.4F, 1.5 and 1.6 (Explosives); — Division 2.3 (Toxic gas); — Materials having either a primary or subsidiary hazard of Division 6.1 with a Packing Group I inhalation toxicity; — Division 6.2 (Infectious substances, Category A); — Class 7 (outside of the United States, Canada and Mexico) — substances requiring a “Radioactive” White-I, Yellow-II or Yellow-III label; <ul style="list-style-type: none"> — Materials requiring a fissile label are not accepted in any UPS service; — Radioactive material, excepted package shipments are also prohibited outside the United States and Canada. 	Table 3-1
	5X-05	When an IATA shipper’s declaration for dangerous goods is required, the shipper must present three original copies.	5:4

- ≠ 5X-06 To maintain compliance with US 18, UPS requires all packages for the materials listed below to comply with United States DOT packaging requirements contained in 49 CFR 173.302(f) and 173.304(f). Such packagings must be marked with the text “DOT31FP” on the outer package. Affected entries are:
- UN 1070 — Nitrous oxide (see 49 CFR 173.340(f))
 - UN 1072 — Oxygen, compressed (see 49 CFR 173.302(f))
 - UN 2451 — Nitrogen trifluoride (see 49 CFR 173.302(f))
 - UN 3156 — Compressed gas, oxidizing, n.o.s. (see 49 CFR 173.302(f))
 - UN 3157 — Liquefied gas, oxidizing, n.o.s. (see 49 CFR 173.304(f))
 - UN 3356 — Oxygen generator, chemical (see 49 CFR 173.168)
 - Carbon dioxide and oxygen mixture, compressed (see 49 CFR 173.304(f))
- ≠ 5X-07 The following limitations apply to the commodities identified here: 2;9
4;11
- depending on the required routing, shipments of UN 3090 — Lithium metal batteries, including Section II shipments, may need to be returned to shippers due to prohibitions on carrying such shipments aboard passenger aircraft.
 - shipments of UN 3077, Environmentally hazardous substance, solid, n.o.s., will not be accepted when contained in intermediate bulk containers (IBCs) in any UPS air services (including UPS small package, UPS freight air services or UPS air cargo services);
 - shipments of UN 2807, Magnetized material, for which the magnetic field strength exceeds 0.00525 gauss when measured at 4.6 metres from any surface of the package are not accepted in UPS services (including UPS small package, UPS freight air services or UPS air cargo services);
 - shipments of refurbished lithium batteries, or refurbished lithium batteries packed with or contained in equipment are not accepted unless specifically approved by the UPS Air Dangerous Goods Department (SDF);
 - shipments of UN 3245, Genetically modified organisms or Genetically modified micro-organisms, with an origin and/or destination outside the United States are not accepted in UPS small package services. For UPS air freight shipments, case-by-case approval is required to assure the ability to import or transit the shipments within the countries involved.
- 7H — ERA AVIATION**
- 7H-01 Shipments under a United States Department of Transportation exemption (DOT-E) must be accompanied by one copy of the exemption document describing the regulation that is exempt and the conditions/provisions thereof. (See 1.2.6.3 and 8.1.6.9.4 of the IATA Dangerous Goods Regulations.)
- 7H-02 Hazardous waste may not be accepted. Thirty (30) days written notification required for determination. (See Packing Instruction 622 and 8.1.3.3 of the IATA Dangerous Goods Regulations.)
- 8V — ASTRAL AVIATION**
- 8V-01 The shipper must provide a 24-hour emergency telephone number of a person/agency who is knowledgeable of the hazards, characteristics and actions to be taken in case of an accident or incident concerning each of the dangerous goods being transported. This telephone number, including the country and area code, preceded by the words “Emergency contact” or “24-hour number” should be shown on the shipper’s declaration for dangerous goods (DGD) in the “Additional handling information” box and on the package (see 8.1.6.11 and 10.8.3.11 of the IATA Dangerous Goods Regulations). 5;4
- 8V-02 Interline transfer of dangerous goods will not be accepted unless a copy of the acceptance checklist accompanies the consignment together with the shipper’s declaration for dangerous goods and the air waybill. 5;4

8X — AIR CARAIBES ATLANTIQUE

8X-01	Only radioactive material Category I-White (IMP code RRW (see B.2.2.4 of the IATA Dangerous Goods Regulations)) where the maximum radiation level at any point on any external surface of a package or overpack does not exceed 0.005 mSv/h is accepted for transport.	2;7 Table 3-1 5;1
-------	--	-------------------------

9S — SOUTHERN AIR

9S-1	Not used.	
------	-----------	--

9W — JET AIRWAYS

9W-01	Used camping stoves (fuel or gas) will not be accepted for carriage in baggage, even if thoroughly cleaned (see 2.3.2.5 of the IATA Dangerous Goods Regulations).	Table 8-1
9W-02	Small gaseous oxygen (oxygen compressed, UN 1072) or air cylinders required for medical use are not permitted in passenger checked or carry-on baggage. Should a passenger require supplementary oxygen, a 48-hour prior request must be made to Jet Airways. Jet Airways Telephone: International: 1800 22 55 22 United Kingdom toll free: 08 081 01 11 99 United States toll free: 1-877-835-9538	Table 8-1
9W-03	Mercury barometers will not be accepted for carriage as carry-on baggage (see 2.3.3.1 of the IATA Dangerous Goods Regulations).	Table 8-1
9W-04	Chemical agent monitoring equipment containing radioactive material will not be accepted for carriage (see 2.3.4.4 of the IATA Dangerous Goods Regulations).	Table 8-1
9W-05	Salvage packagings will not be accepted for carriage (see 5.0.1.6, 6.0.6, 6.7, 7.1.5, 7.2.3.10 of the IATA Dangerous Goods Regulations).	4;1.4 5;1.5 5;2.4 6;1.2.6 6;2.3 6;4.8
9W-06	Hazardous waste in any form, as defined by any regulation, will not be accepted for carriage (see Packing Instruction 622 and 8.1.3.3 of the IATA Dangerous Goods Regulations).	4;8
9W-07	The shipper must provide a 24-hour emergency telephone number of a person/agency who is knowledgeable of the hazards, characteristics and actions to be taken in case of an accident or incident concerning each of the dangerous goods being transported. This telephone number, including the country and area code, preceded by the words "Emergency contact" or "24-hour number" must be inserted on the shipper's declaration for dangerous goods (DGD) (see 8.1.6.11 and 10.8.3.11 of the IATA Dangerous Goods Regulations).	5;4
9W-08	Dangerous goods as defined in any regulation will not be accepted in airmail (see 2.4 and 10.2.2 of the IATA Dangerous Goods Regulations).	1;2.3
9W-09	Not used.	
9W-10	Class 1 — Explosives will not be accepted for carriage except substances and articles of Division 1.4S, UN 0012 or UN 0014 only (see Packing Instruction 130).	2;1 4;3
9W-11	Class 3 — Desensitized explosives will not be accepted for carriage.	2;1
9W-12	Class 4 — Flammable solids (including Divisions 4.1, 4.2 and 4.3) will not be accepted for carriage.	2;6
9W-13	Division 6.1 — Substances of Packing Group I will not be transported except when transported under the excepted quantity provisions (see 2.6 of the IATA Dangerous Goods Regulations).	2;6 3;4

**AIRLINE OPERATOR VARIATIONS FROM
THE TECHNICAL INSTRUCTIONS FOR THE
SAFE TRANSPORT OF DANGEROUS GOODS BY AIR**

To: Chief, Cargo Safety Section (CSS)
International Civil Aviation Organization
999 University Street
Montréal, Quebec
CANADA H3C 5H7

Email: krooney@icao.int

Please include in the Addendum to the 2015-2016 Edition of the Technical Instructions the following operator variation(s):

Variation

Relevant paragraphs

_____ Signature

_____ Title

(To be returned to reach ICAO not later than 15 April 2015)

Attachment 4

**INDEX AND LIST OF
TABLES AND FIGURES**

INDEX

	<i>Part</i>	<i>Paragraph</i>
A		
Abbreviations and symbols		
general	Foreword	—
as used in Table 3-1	3	2.1.2
Acceptance of dangerous goods		
acceptance check	7	1.3
cargo acceptance procedures	7	1.1
checklist	7	1.3
infectious substances — special responsibilities	7	1.5
freight containers and unit load devices	7	1.4
minor discrepancies	3	1.2.2
.....	7	1.3.1 Note 1
operators — general procedures	7	1.2
undeliverable consignments of radioactive material	7	1.6
Accessibility of 'Cargo aircraft only' packages	7	2.4.1
Accidents and incidents		
aircraft carrying dangerous goods — action by operator	7	4.7
dangerous goods — reporting by operators	7	4.4
dangerous goods — reporting by entities other than operators	1	7
Accumulation of packages and freight containers of radioactive material	7	2.9.3.3
Activity levels of radioactive material	2	7.2.1; 7.2.2
Aerosols		
definition	1	3.1.1
divisions	2	2.5
flammable — criteria	2	2.5.2
packagings — requirements	6	3.2.7
subsidiary risks	2	2.5
Airmail	1	2.3
Air waybill	5	4.2
Aluminium boxes (4B)		
performance tests	6	4
specifications	6	3.1.13
Aluminium drums (1B1, 1B2)		
performance tests	6	4
specifications	6	3.1.2
Amendments to Technical Instructions	1	1.6
Animals		
infected	2	6.3.6
veterinary aid	1	1.1.5.1 b)
separation from radioactive materials	7	2.9.6.3
with dry ice	7	2.11
Annex 18 — relationship	1	1.5
Applicability of the Technical Instructions	1	1.1
Application		
labels	5	3.2
markings	5	2.2
Approvals	1	1.1.2
B		
Bags, paper — specifications	6	3.2.4
Bags, paper, multiwall (5M1), multiwall water-resistant (5M2)		
specifications	6	3.1.17
Bags, plastic — specification	6	3.2.5
Bags, plastic film (5H4)		
performance tests	6	4
specifications	6	3.1.16
Bags, textile (5L2, 5L3)		
performance tests	6	4
specifications	6	3.1.14

	<i>Part</i>	<i>Paragraph</i>
Bags, woven plastic (5H1, 5H2, 5H3)		
performance tests	6	4
specifications	6	3.1.15
Barometers, with government official	8	Table 8-1 22)
Biological products		
classification	2	6.3.3
definition	2	6.3.1.2
Boxes, fibre — specifications	6	3.2.6
Boxes, fibreboard (4G)		
performance tests	6	4
specifications	6	3.1.11
Boxes, natural wood (4C1, 4C2)		
performance tests	6	4
specifications	6	3.1.8
Boxes, plastic (4H1, 4H2)		
performance tests	6	4
specifications	6	3.1.12
Boxes, plywood (4D)		
performance tests	6	4
specifications	6	3.1.9
Boxes, reconstituted wood (4F)		
performance tests	6	4
specifications	6	3.1.10
Boxes, steel or aluminium (4A, 4B)		
performance tests	6	4
specifications	6	3.1.13

C

Cans, fibre — specifications	6	3.2.6
Cans, tins or tubes (metal) — specifications	6	3.2.3
Cargo acceptance procedures	7	1.1
Cargo aircraft		
loading	7	2.4.1
Checklist for acceptance of dangerous goods by operators	7	1.3
<i>Class 1 (Explosives)</i>		
classification	2	1.5
classification codes	2	Table 2-2
compatibility groups	2	1.4
definitions and general provisions	2	1.1
divisions	2	1.3
general packing provisions	4	3.3
general requirements	4	3.2
label specifications	5	3.5.1 c)
package markings	5	2.4.3
packing group	4	3.1
packing instructions	4	3.4
separation of explosive substances and articles	7	2.2.2
<i>Class 2 (Gases)</i>		
aerosols — see Aerosols		
construction and testing	6	5
definitions and general provisions	2	2.1
divisions	2	2.2
hazard precedence	2	2.3
mixtures	2	2.4
packing instructions	4	4.2
refrigerated liquefied — handling label	5	3.2.12 c)
<i>Class 3 (Flammable liquids)</i>		
definition and general provisions	2	3.1
flash point determination	2	3.3
packing group assignment	2	3.2
packing instructions	4	5.1
<i>Class 4 (Flammable solids, etc.)</i>		
definitions and general provisions	2	4.1
flammable solids — classification and packing groups	2	4.2
list of currently assigned self-reactive substances	2	4.2.3.2.4; Table 2-6

	<i>Part</i>	<i>Paragraph</i>
packing instructions	4	6.2
substances liable to spontaneous combustion		
classification and packing groups	2	4.3
substances which, in contact with water, emit flammable gases		
classification and packing groups	2	4.4
<i>Class 5 (Oxidizing substances and organic peroxides)</i>		
definitions and general provisions	2	5.1
Division 5.1		
classification	2	5.3.2
desensitization	2	5.3.4
general requirements	4	7.1
list of currently assigned organic peroxides	2	5.3.2.4; Table 2-7
properties	2	5.3.1
oxidizing substances		
classification and packing groups	2	5.2.2
packing instructions	4	7.2
<i>Class 6 (toxic and infectious substances)</i>		
biological products	2	6.3.3
clinical waste	2	6.3.5
definitions	2	6.1
genetically modified organisms and micro-organisms	2	6.3.4
infectious substances		
classification of	2	6.3.2
damage or leakage	7	3.1.4
definitions	2	6.3.1
in airmail	1	2.3
packagings	6	6
test report	6	6.5.5
transport document	5	4.1.5.8
medical waste	2	6.3.5
packing instructions	4	8.1
pesticides, classification	2	6.2.4
toxic substances, packing group assignment	2	6.2.2
<i>Class 7 (Radioactive material)</i>		
accumulation of packages and freight containers	7	2.9.3.3
activity levels	2	7.2.2
approvals of package designs and materials	6	7.21
classification		
general provisions	2	7.2.1
packages	2	7.2.4
criticality safety index	5, 6	1.2.3, 7.10
damaged packages	7	3.2
definitions	2	7.1
documentation		
excepted package	5	1.2.4
competent authority certificates	5	1.2.2
information on dangerous goods transport document	5	4.1.5.6
exclusive use	7	2.9.3.4
fissile material		
definition	2	7.1.3
determination of other material characteristics	2	7.2.3.5
packages	4	9.1.1
.....	6	7.10; 7.18
general provisions	1	6
.....	5	1.2
in airmail	1	2.3
industrial packages		
requirements	6	7.4
low specific activity (LSA) materials		
definition	2	7.1.3
determination of groups	2	7.2.3.1.2
determination of other material characteristics	2	7.2.3
requirements and controls for transport	4	9.2
material characteristics		
fissile material	2	7.2.3.5
low specific (LSA)	2	7.2.3.1
low dispersible	2	7.2.3.4
special form	2	7.2.3.3

	<i>Part</i>	<i>Paragraph</i>
surface contaminated object	2	7.2.3.2
non-compliance	1	6.6
packagings		
requirements	6	7.2
target for drop tests	6	7.13
testing of integrity of containment system and shielding	6	7.12
test procedures	6	7.11
tests for normal conditions of transport	6	7.14
tests for accident conditions in transport	6	7.16
packing requirements	4	9.1
placarding of large freight containers	5	3.6
radiation levels for packages and overpacks	4	9.1
.....	5	1.2.3.1.4
registration of serial numbers	6	7.23
requirements for		
excepted packages	6	7.3
industrial packages	6	7.4
packages containing fissile material	6	7.10
packages containing Uranium hexafluoride	6	7.5; 7.20
Type A packages	6	7.6; 7.15
gases	6	7.6.17
liquids	6	7.6.16
Type B(M) packages	6	7.8; 7.17
Type B(U) packages	6	7.7; 7.17
Type C packages	6	7.9; 7.19
security	1	5.5
separation		
from film	7	2.9.6.2
from live animals	7	2.9.6.3
from persons	7	2.9.6.1
special form	2	7.2.3.3
surface contaminated object (SCO)		
determination of groups	2	7.2.3.2
requirements and controls for transport	4	9.2
transport index		
definition	2	7.1.3
determination	5	1.2.3
limits	4	9.1.10
exclusive use	7	2.9.3.4
target for drops tests	6	7.13
test procedures	6	7.11
testing the integrity of the containment system and shielding and		
evaluating criticality safety	6	7.12
tests for demonstrating ability to withstand accident conditions in transport	6	7.16
tests for demonstrating ability to withstand normal conditions of transport	6	7.14
transitional measures for Class 7	6	7.23
<i>Class 8 (Corrosive substances)</i>		
definition	2	8.1
packing group assignment	2	8.2
packing instructions	4	10
<i>Class 9 (Miscellaneous)</i>		
assignment	2	9.2
definition	2	9.1
lithium batteries — see Lithium batteries		
magnetized material — explanation	2	9.2.1 d)
packing instructions	4	11
Class hazard label specifications	5	3.5.1
Classification of organometallic substances	2	4.5
Classification of pesticides	2	6.2.4
Classification of substances and articles with multiple hazards	2	Introductory Chapter, 4
Clinical waste	2	6.3.5
Coated packagings — testing	6	4.1.9
Compatibility group assignment for explosives	2	Table 2-3
Composite packagings (plastic material) (6HA1, 6HA2, 6HB1, 6HB2, 6HC, 6HD1, 6HD2, 6HG1, 6HG2, 6HH1, 6HH2)		
performance tests	6	4
specifications	6	3.1.18
Consignee identification on packages	5	2.4.2

	<i>Part</i>	<i>Paragraph</i>
Contaminated baggage or cargo, suspected.....	7	3.3
Conversion factors for SI/Non-SI units	1	3.2.3
Corrosives — see Class 8		
Cushioning of inner packagings.....	4	1.1.10
 D		
Damaged packages		
inspection for	7	3.1
loading	7	3.1
radioactive material	7	3.2
Dangerous goods		
accident and incident reporting	7	4.4
definitions.....	1	3.1
excepted quantities.....	3	5
radioactive material	1	6.1.5
exceptions for the operator.....	1	2.2
forbidden on aircraft under any circumstance	1	2.1
in airmail	1	2.3
information required.....	5	4
in passengers' baggage	8	1.1
limited quantities	3	4
list of	3	Table 3-1
multiple hazards	2	Introductory
not otherwise specified (n.o.s.).....	3	Chapter, 4
numerical list.....	Att. 1	1.2.7
packed together.....	4	Chapter 1
transport document.....	5	1.1.8; 1.1.9
transport document.....	5	4.1
Definitions (see also Nomenclature).....	1	3.1
Documentation for dangerous goods.....	5	4
Drums, aluminium (1B1, 1B2)		
performance tests.....	6	4
specifications	6	3.1.2
Drums, fibre (1G)		
performance tests.....	6	4
specifications	6	3.1.6
Drums, metal other than aluminium or steel (1N1, 1N2)		
performance tests.....	6	4
specifications	6	3.1.3
Drums, plastic (1H1, 1H2)		
performance tests.....	6	4
specifications	6	3.1.7
Drums, plywood (1D)		
performance tests.....	6	4
specifications	6	3.1.5
Drums, steel (1A1, 1A2)		
performance tests.....	6	4
specifications	6	3.1.1
 E		
Earthenware, glass or wax receptacles (IP.1) — specifications.....	6	3.2.1
Emergency response information	7	4.9
Environmentally hazardous substances	2	9.2
marking requirements.....	5	2.4.9
Excepted packages of radioactive material	1	6.1.5
Excepted quantities of dangerous goods	3	5
Exceptions		
dangerous goods of the operator	1	2.2
general.....	1	1.1.5
Exemptions — granting of.....	1	1.1.3
Explanation of terms	Att. 2	—
Explosives — see Class 1		

	<i>Part</i>	<i>Paragraph</i>
F		
Fibreboard boxes (4G)		
performance tests.....	6	4
specifications.....	6	3.1.11
Fibre cans or boxes — specifications.....	6	3.2.6
Fibre drums (1G)		
performance tests.....	6	4
specifications.....	6	3.1.6
Fissile material — see Class 7		
Flammable aerosols — criteria.....	2	2.5.2
Flammable liquids — see Class 3		
Flammable solids — see Class 4		
Flammable viscous substances with a flash point less than 23°C — grouping.....	2	3.2.2
Flash point determination.....	2	3.3
Flight deck — loading restrictions.....	7	2.1
Forbidden dangerous goods		
under any circumstance.....	1	2.1
Format of packing instructions.....	4	2
Freight containers for radioactive material		
loading.....	7	2.9.3.3
placarding.....	5	3.6
Frequency of testing of packagings.....	6	4.1
G		
Gas cylinders.....	6	5
Gases — hazard precedence.....	2	2.3
Gases, refrigerated liquefied — packaging.....	6	5
Gases — see Class 2		
Generic proper shipping names, List of.....	Att. 1	Chapter 2
Genetically modified micro-organisms and organisms.....	2	6.3.4; 9.1.2
Glass — specifications.....	6	3.2.1
H		
Handling and loading of packages containing liquid dangerous goods.....	7	2.3
Handling labels.....	5	3.5.2
Cargo Aircraft Only label.....	5	3.2.12 a)
Cryogenic Liquid label.....	5	3.2.12 c)
Keep Away from Heat label.....	5	3.2.12 d)
Lithium Battery Handling label (PI 965-PI 970).....	5	3.5.2.1
Magnetized Material label (Table 3-1; PI 953 and PI 962 (for UN 3363 if applicable)).....	5	3.2.11
Package Orientation label (PI 962 (for UN 3363) and PI Y963 (for ID 8000)).....	4,5	1.1.13; 3.2.12 b)
Radioactive material, excepted package.....	5	3.2.12 e)
Helicopters		
Information to the pilot-in-command.....	7	4.1.1
Special provisions for.....	7	7
I		
ID number.....	1	3.1
Incidents — see Accidents and Incidents		
Incompatible dangerous goods		
packing together.....	4	1.1.8
segregation.....	7	2.2.1
Index of packaging specifications.....	6	1.3
Industrial packages for radioactive material.....	6	7.4
Infectious substances — see Class 6		

	<i>Part</i>	<i>Paragraph</i>
Information, provision of		
by operator after an aircraft accident or incident.....	7	4.7
by pilot-in-command in an in-flight emergency.....	7	4.3
cargo acceptance areas.....	7	4.8
dangerous goods not required to appear in the information to the pilot-in-command.....	7	Table 7-9
emergency response.....	7	4.9
for helicopter operations.....	7	4.1.1
for lithium batteries.....	7	4.1.3
to operator's employees.....	7	4.2
to personnel with responsibilities for operational control of the aircraft.....	7	4.1
to pilot-in-command.....	7	4.1
Inner packagings		
specifications.....	6	3.2
use of cushioning and absorbent materials.....	4	1.1.10
Inspection for damage or leakage.....	7	3.1
J		
Jerricans, plastic (3H1, 3H2)		
performance tests.....	6	4
specifications.....	6	3.1.7
Jerricans, steel (3A1, 3A2)		
performance tests.....	6	4
specifications.....	6	3.1.4
L		
Labels and labelling		
application of labels.....	5	3.2
labelling of packages and overpacks.....	5	3
labelling of unit load devices.....	7	2.8
other modes of transport.....	5	3.2.14
prohibited labelling.....	5	3.4
replacement of labels.....	7	2.7
requirement to label.....	5	3.1
specifications for labels.....	5	3.5
Languages to be used		
dangerous goods transport document.....	5	4.1.6.3
labels.....	5	3.2.12
markings on packages.....	5	2.5
Leakage — inspection for.....	7	3.1
Leaking packages of radioactive material.....	7	3.2
Limitation of dangerous goods on aircraft.....	1	2
Limited quantities of dangerous goods.....	3	4
Liquid dangerous goods		
definition.....	1	3.1
loading.....	7	2.3
orientation of combination packagings.....	4	1.1.13
List of currently assigned organic peroxides.....	2	5.3.2.4; Table 2-7
List of currently assigned self-reactive substances.....	2	Table 2-6
List of dangerous goods.....	3	Table 3-1
List of n.o.s. and generic proper shipping names.....	Att. 1	Chapter 2
Lithium batteries		
assignment.....	2	9.3
in airmail.....	1	2.3.2
packing instructions.....	4	11
quality management system.....	2	9.3.1 e)
Loading		
cargo aircraft.....	7	2.4.1
dry ice.....	7	2.11
expandable polymeric beads.....	7	2.12
magnetized material.....	7	2.10
restrictions on flight deck and for passenger aircraft.....	7	2.1
segregation from other dangerous goods.....	7	2.2.1
Low specific activity radioactive material — see Class 7		

	<i>Part</i>	<i>Paragraph</i>
M		
Magnetized material		
definition	2	9.2 d)
loading	7	2.11
Markings		
application of	5	2.2
biological substances, Category B	5	2.4.8
Class 1 packages	5	2.4.3
dry ice	5	2.4.7
infectious substances	6	2.2
marking requirements	5	2.4.5
languages to be used	5	2.5
other modes of transport	5	2.4.13
packages and overpacks	5	2.4.10
packaging specifications		
detailed requirements	6	2
general	5	2.4.4
prohibited	5	2.3
proper shipping name and UN number	5	2.4.1
radioactive material requirements	5	2.4.5
refrigerated liquefied gas	5	2.4.6
shipper and consignee identification	5	2.4.2
special marking requirements for:		
biological substances, Category B	5	2.4.8
chemical oxygen generators	5	2.4.14
dry ice	5	2.4.7
environmentally hazardous substances	5	2.4.9; 2.4.15
explosives	5	2.4.3
IBCs used to transport UN 3077	5	2.4.9; 2.4.15
radioactive material	5	2.4.5
refrigerated liquefied gas	5	2.4.6
specifications and requirements	5	2.4
Measurement units and conversion factors	1	3.2
Medical waste	2	6.3.5
Mercury barometer, with government official	8	Table 8-1 22)
Metal cans, tins or tubes — specifications	6	3.2.3
Metal or plastic flexible tubes — specifications	6	3.2.9
Miscellaneous dangerous goods — see Class 9		
Mixtures and solutions containing one dangerous substance	3	1.3
Mixtures of gases	2	2.4
Multiple hazard dangerous goods — classification	2	Introductory Chapter, 4
N		
Natural wood boxes (4C1, 4C2)		
performance tests	6	4
specifications	6	3.1.8
Non-SI units of measurement	1	3.2.2
Not otherwise specified (n.o.s.) dangerous goods		
list	Att. 1	Chapter 2
rules for use	3	1.2.7
O		
Operator		
acceptance check	7	1.3
acceptance of dangerous goods	7	1
acceptance of infectious substances	7	1.5
decontamination of aircraft	7	3
inspection of packages		
on acceptance	7	1
on unloading	7	3.1.3
prior to loading	7	3.1
loading	7	2

	<i>Part</i>	<i>Paragraph</i>
provision of information	7	4
responsibilities	7	—
Opening of dangerous goods packages	1	1.4
Organic peroxides		
additional transport document information	5	4.1.5.4; 4.1.5.8.3
Keep Away from Heat label	5	3.2.12 d)
Organic peroxides, list of currently assigned	2	Table 2-7
Organic peroxides — see Class 5		
Orientation of combination packages containing liquids	4	1.1.13
Overpacks		
labelling	5	3.3
marking	5	2.4.10
Oxidizing substances — see Class 5		

P

Packages and packagings		
aerosol dispensers	6	5
compatibility of parts of packagings	4	1.1.3.1
cylinders and closed cryogenic receptacles	6	5
empty	4	1.1.15
gas cartridges	6	5
minimum size	4	1.1.14
orientation of combination packages containing liquids	4	1.1.13
performance and frequency of tests	6	4.1
preparation for tests	6	4.2
pressure testing of packagings for liquids	4	1.1.6
salvage	4	1.4
additional information on dangerous goods transport document	5	4.1.5.1 d)
test requirements	6	4.8
specification markings		
detailed requirements	6	2
general	5	2.4.4
specifications and tests	6	—
specifications index	6	1.3
supplementary packagings — use of	4	1.1.7
testing requirements	6	4
test report	6	4.7
transitional arrangements for radioactive material	4	1.3
Packing group		
Class 1	4	3.1
criteria for Class 3	2	3.2
criteria for Class 8	2	8.2
criteria for Division 4.1	2	4.2.2.3
criteria for Division 4.2	2	4.3.3
criteria for Division 4.3	2	4.4.3
criteria for Division 5.1	2	5.2.2.2
criteria for Division 5.2	4	7.1.1
criteria for Division 6.1	2	6.2.2
explanation	4	Note 1
performance requirement	4	1.2
Packing instructions		
Class 1	4	3.4
Class 2	4	4.2
Class 3	4	5.1
Class 4	4	6.2
Class 5	4	7.2
Class 6	4	8.1
Class 8	4	10.1
Class 9	4	11
format	4	2
Packing requirements		
compatibility	4	1.1.3
excepted quantities	3	5.2
explosives	4	3.2
general	4	1.1

	<i>Part</i>	<i>Paragraph</i>
limited quantities	3	4.2
organic peroxides	4	7.1
self-reactive substances	4	6.1
Packing together of different dangerous goods	4	1.1.8
Paper bags — specifications	6	3.2.4
Paper bags, multiwall, water-resistant (5M2)		
performance tests	6	4
specifications	6	3.1.17
Passenger aircraft — loading restrictions	7	2.1
Passengers		
check-in procedures	7	5.2
permitted dangerous goods in baggage, etc.	8	1.1.2
provision of information to	7	5.1
Pesticides — classification	2	6.2.4
Placarding of large freight containers containing radioactive material	5	3.6
Placarding of portable tanks	5	Ch. 3, Note 3
Plastic — specifications	6	3.2.2
Plastic bags — specifications	6	3.2.5
Plastic boxes (4H1, 4H2)		
performance tests	6	4
specifications	6	3.1.12
Plastic drums (1H1, 1H2)		
performance tests	6	4
specifications	6	3.1.7
Plastic fabric bags — see woven plastic bags		
Plastic film bags (5H4)		
performance tests	6	4
specifications	6	3.1.16
Plastic flexible tubes — specifications	6	3.2.9
Plastic jerricans (3H1, 3H2)		
performance tests	6	4
specifications	6	3.1.7
Plastic receptacles (aerosols) non-refillable (IP.7C) — specifications	6	3.2.8
Plastic receptacles with outer protection (6HA1, 6HA2, 6HB1, 6HB2, 6HC, 6HD1, 6HD2, 6HG1, 6HG2, 6HH1, 6HH2)		
performance tests	6	4
specifications	6	3.1.18
Plywood boxes (4D)		
performance tests	6	4
specifications	6	3.1.9
Plywood drums (1D)		
performance tests	6	4
specifications	6	3.1.5
Poisons — see Class 6		
Portable tanks	4	Introductory Chapter, Note 6
Precedence of hazards	2	Introductory Chapter, 4
Pressure requirements for liquid containers		
all classes except Class 7	4	1.1.6
consumer commodities	4	PI Y963
Division 6.2	4	PI 620
Pressure testing of packagings for liquids	4	1.1.6
Pressure variations in air transport	4	Introductory Chapter, Note 3
Prohibited labelling	5	3.4
Prohibited markings on packages	5	2.3
Proper shipping name and UN number	3	1.2
minor discrepancies	7	1.3.1 Note 1
singular or plural, preferred spelling, alternative spelling	3	1.2.2
Provision of information — see Information, provision of		
Provisions, special	3	Table 3-2
Pyrophoric substances — see Class 4		

	<i>Part</i>	<i>Paragraph</i>
R		
Radioactive material — see Class 7		
Readily combustible solids — see Class 4		
Reconstituted wood boxes (4F)		
performance tests.....	6	4
specifications	6	3.1.10
Refrigerated liquefied gases — packaging.....	6	5
Replacement of labels	7	2.7
Reporting of dangerous goods accidents and incidents		
by operators.....	7	4.4
by entities other than operators.....	1	7
Reporting of dangerous goods occurrences.....	7	4.6
Reporting of undeclared or misdeclared dangerous goods		
by operators.....	7	4.5
by entities other than operators.....	1	7
S		
Samples, transport of.....	2	Introductory Chapter, 5
Salvage packagings, see Packages and packagings, salvage		
Securing of dangerous goods.....	7	2.4.2
Security of dangerous goods		
general.....	1	5.1
high consequence dangerous goods	1	5.3
security plans.....	1	5.4
training	1	5.2
Segregation of incompatible dangerous goods	7	2.2
Self-heating substances — see Class 4		
Self-reactive substances		
list of currently assigned.....	2	Table 2-6
transport document.....	5	4.1.5.4
Shipper		
documentation	5	4
labelling.....	5	3
marking	5	2
requirements		
general	5	1.1
responsibilities	5	—
SI units and conversion factors.....	1	3.2
Special form radioactive material — see Class 7		
Special Marking — see Markings		
Special provisions.....	3	3
Specification markings for packages and packagings — see Packages and packagings		
Spontaneous combustion substances — see Class 4		
Steel boxes (4A)		
performance tests.....	6	4
specifications	6	3.1.13
Steel drums (1A1, 1A2)		
performance tests.....	6	4
specifications	6	3.1.1
Steel jerricans (3A1, 3A2)		
performance tests.....	6	4
specifications	6	3.1.4
Stowage of toxic and infectious substances.....	7	2.9
Substances which, in contact with water, emit flammable gases — see Class 4		
Supplement to the Technical Instructions.....	Foreword	—
Supplementary packaging	4	1.1.7
Surface contaminated object (SCO) — see Class 7		

	<i>Part</i>	<i>Paragraph</i>
T		
Technical Instructions		
general basis for	Foreword	—
operational use of	Foreword	—
use of	Foreword	—
variations from		
general	Foreword	—
notifications	Att. 3	—
Temperature variations in air transport.....	4	Introductory Chapter, Note 2
Test report — packaging.....	6	4.7
Textile bags (5L2, 5L3)		
performance tests.....	6	4
specifications	6	3.1.14
Tins, tubes or cans — metal — specifications.....	6	3.2.3
Toxic gases — see Class 2		
Toxic liquids/solids — see Class 6		
Training programmes		
curricula	1	4.2
establishment of	1	4.1
for designated postal operators.....	1	4.2.8
instructor qualifications.....	1	4.3
record of training.....	1	4.2.5
recurrent training	1	4.2.3
review and approval of	1	4.1.2
security awareness.....	1	5.2
testing	1	4.2.4
Transport document for dangerous goods	5	4.1
Transport requirements — general.....	1	1.2
Tubes, flexible metal or plastic — specifications.....	6	3.2.9
Type A packages and packagings for radioactive material — see Class 7		
Type B packages and packagings for radioactive material — see Class 7		
U		
Ullage		
consumer commodities.....	4	PI Y963
general.....	4	1.1.5
Unit load device		
acceptance by operator.....	7	1.4
labelling.....	7	2.7
Units		
conversion factors	1	3.2.3
measurement.....	1	3.2.1
non-SI	1	3.2.2
Unpackaged articles	4	2.9
Use of the Technical Instructions		
guidance in use of the document	Foreword	—
operational.....	Foreword	—
V		
Variations found in air transport		
pressure.....	4	Introductory Chapter, Note 3
temperature	4	Introductory Chapter, Note 2
Variations from the Technical Instructions		
general.....	Foreword	—
notifications.....	Att. 3	—
Vibrations found in air transport.....	4	Introductory Chapter,

	<i>Part</i>	<i>Paragraph</i>
		Note 4
W		
Waste dangerous goods — documentation	5	4.1.4.3 c)
Water-reactive substances — see Class 4		
Wheelchairs, electric and other battery-powered mobility aids	8	Table 8-1 5) and 6)
Woven plastic bags (5H1, 5H2, 5H3)		
performance tests	6	4
specifications	6	3.1.15

LIST OF TABLES

	<i>Page</i>
Table 1-1	Authorized equivalents 1-3-9
Table 1-2	Conversion to SI units 1-3-9
Table 1-3	Conversion from SI units 1-3-10
Table 1-4	Content of training courses 1-4-2
Table 1-5	Content of training courses for operators not carrying dangerous goods as cargo 1-4-3
Table 1-6	Content of training courses for staff of designated postal operators 1-4-4
Table 1-7	Indicative list of high consequence dangerous goods 1-5-2
Table 1-8	Transport security thresholds for specific radionuclides 1-5-2
Table 2-1	Precedence of hazards and packing groups for Classes 3, 4 and 8 and for Divisions 5.1 and 6.1 2-0-5
Table 2-2	Classification codes 2-1-3
Table 2-3	Scheme of classification of explosives, combination of hazard division with compatibility group 2-1-4
Table 2-4	Packing group based on flammability 2-3-3
Table 2-5	Viscosity and flashpoints 2-3-3
Table 2-6	List of currently assigned self-reactive substances in packages 2-4-4
Table 2-7	List of currently assigned organic peroxides in packages 2-5-5
Table 2-8	Grouping criteria for administration through oral ingestion, dermal contact and inhalation of dusts and mists 2-6-2
Table 2-9	Criteria for inhalation 2-6-2
Table 2-10	Indicative examples of infectious substances included in Category A in any form unless otherwise indicated 2-6-7
Table 2-11	Assignment of UN numbers 2-7-2
Table 2-12	Basic radionuclides values for individual radionuclides 2-7-5
Table 2-13	Basic radionuclide values for unknown radionuclides or mixtures 2-7-19
Table 2-14	Activity limits for excepted packages 2-7-25
Table 2-15	Summary of criteria for assigning packing groups to corrosive substances 2-8-2
Table 3-1	Dangerous Goods List 3-2-3
Table 3-2	Special provisions 3-3-1
Table 3-3	Excepted quantity codes for Table 3-1 3-5-1
Table 4-1	Examples of required marked test pressures calculated as in 1.1.16 c) 4-1-5
Table 4-2	Industrial package requirements for LSA material and SCO 4-9-3
Table 5-1	Multiplication factors for freight containers 5-1-4
Table 5-2	Categories of packages and overpacks 5-1-5
Table 6-1	Applicability of Chapters 6-1-1
Table 6-2	Index of packagings other than inner packagings 6-1-2
Table 6-3	Index of inner packagings 6-1-4
Table 6-4	Tests required for packaging types 6-6-3
Table 6-5	Insulation data 6-7-5
Table 6-6	Free drop distance for testing packages to normal conditions of transport 6-7-8
Table 7-1	Segregation between packages 7-2-2
Table 7-2	Separation of explosive substances and articles 7-2-2
Table 7-3	Minimum distance from surface of packages, overpacks and freight containers of radioactive material to the nearest inside surface of passenger cabin or flight deck partitions or floors, irrespective of carriage duration 7-2-5
Table 7-4	Minimum distance from surface of packages, overpacks and freight containers of radioactive material, carried by cargo aircraft only, to the nearest inside surface of the flight deck partitions or floor, or other areas occupied by personnel, irrespective of carriage duration 7-2-6
Table 7-5	Aircraft activity limits for LSA material and SCO in industrial packages 7-2-7
Table 7-6	Transport index limits for freight containers and aircraft not under exclusive use 7-2-7
Table 7-7	Critical Safety Indexes limits for freight containers and aircraft containing fissile material 7-2-7
Table 7-8	Minimum distance in metres from surface of each package, overpack or freight container of radioactive material to undeveloped photographic films or plates, for carriage lasting up to 48 hours 7-2-9
Table 7-9	Dangerous goods not required to appear in the information to the pilot-in-command 7-4-2
Table 8-1	Provisions for dangerous goods carried by passengers or crew 8-1-1
Table A-1	State variations A3-1-2
Table A-2	Operator variations A3-2-3

LIST OF FIGURES

	<i>Page</i>
Figure 2-1	Criteria for inhalation of vapours 2-6-3
Figure 3-1	Limited quantities mark 3-4-3
Figure 3-2	Excepted quantities mark 3-5-3
Figure 5-1	Basic trefoil symbol with proportions based on a central circle of radius X. The minimum allowable size of X must be 4 mm 5-2-3
Figure 5-2	Symbol (fish and tree): black on white or suitable contrasting background 5-2-4
Figure 5-3	Class/division label 5-3-6
Figure 5-4	Explosive, Class 1, Divisions 1.1, 1.2 and 1.3 (label illustration) 5-3-7
Figure 5-5	Explosive, Class 1, Division 1.4 (label illustration) 5-3-7
Figure 5-6	Explosive, Class 1, Division 1.5 (label illustration) 5-3-8
Figure 5-7	Explosive, Class 1, Division 1.6 (label illustration) 5-3-8
Figure 5-8	Flammable gas, Class 2, Division 2.1 (label illustration) 5-3-9
Figure 5-9	Non-flammable, non-toxic gas, Class 2, Division 2.2 (label illustration) 5-3-9
Figure 5-10	Toxic gas, Class 2, Division 2.3 (label illustration) 5-3-10
Figure 5-11	Flammable liquid, Class 3 (label illustration) 5-3-10
Figure 5-12	Flammable solid, Class 4, Division 4.1 (label illustration) 5-3-11
Figure 5-13	Substance liable to spontaneous combustion, Class 4, Division 4.2 (label illustration) 5-3-11
Figure 5-14	Substance which, in contact with water, emits flammable gas, Class 4, Division 4.3 (label illustration) 5-3-12
Figure 5-15	Oxidizing substance, Class 5 (label illustration) 5-3-12
Figure 5-16	Organic peroxide, Class 5, Division 5.2 5-3-13
Figure 5-17	Toxic substance, Class 6, Division 6.1 (label illustration) 5-3-13
Figure 5-18	Infectious substance, Class 6, Division 6.2 (label illustration) 5-3-14
Figure 5-19	Radioactive material, Class 7, Category I (label illustration) 5-3-14
Figure 5-20	Radioactive material, Class 7, Category II (label illustration) 5-3-15
Figure 5-21	Radioactive material, Class 7, Category III (label illustration) 5-3-15
Figure 5-22	Criticality safety index label 5-3-16
Figure 5-23	Corrosive, Class 8 (label illustration) 5-3-16
Figure 5-24	Miscellaneous dangerous goods, Class 9 (label illustration) 5-3-17
Figure 5-25	Magnetized material (label illustration) 5-3-17
Figure 5-26	Cargo aircraft only (label illustration) 5-3-18
Figure 5-27	Package orientation (label illustration) 5-3-18
Figure 5-28	Radioactive material, Class 7, placard for large freight containers 5-3-19
Figure 5-29	Cryogenic liquid label 5-3-20
Figure 5-30	Keep away from heat 5-3-21
Figure 5-31	Radioactive material, excepted package 5-3-22
Figure 5-32	Lithium battery handling label 5-3-23
Figure 6-1	IBCs capable of being stacked 6-2-4
Figure 6-2	IBCs not capable of being stacked 6-2-4
Figure 6-3	Cylindrical steel rod used for puncture test 6-6-5

— END —

ISBN 978-92-9249-582-4



9

789292

495824